

W. PORTER.
Cotton Seed Huller.

No. 102,152.

Patented April 19, 1870.

Fig 1

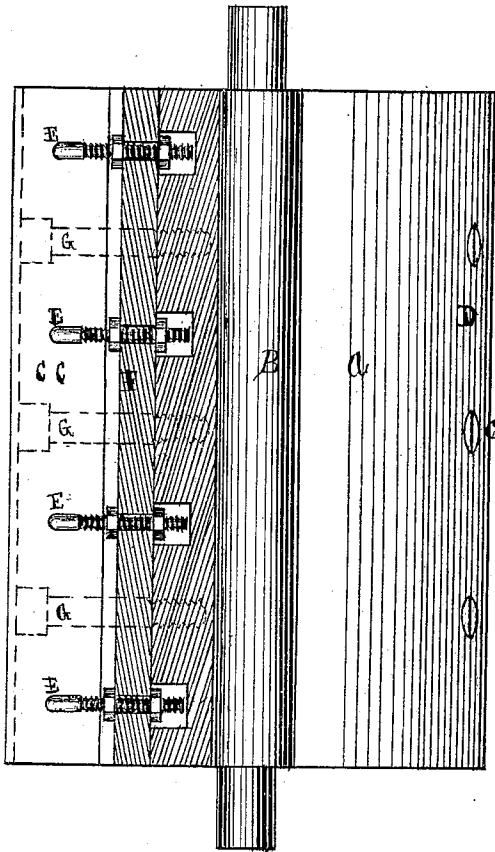
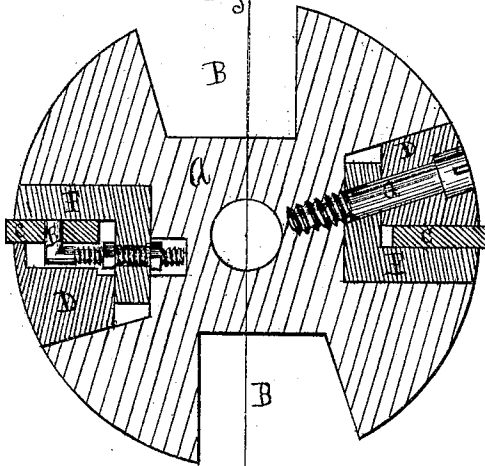

Fig 2



Witnesses.

William Arthur, Junr.

Alex. S. Archer.

Inventor.

William Porter

United States Patent Office.

WILLIAM PORTER, OF BROOKLYN, NEW YORK.

Letters Patent No. 102,152, dated April 19, 1870.

IMPROVEMENT IN HULLING-MACHINES.

The Schedule referred to in these Letters Patent and making part of the same.

To all whom it may concern:

Be it known that I, WILLIAM PORTER, of Brooklyn, in the county of Kings and State of New York, have invented a new and useful Improvement on a Hulling-Machine for Cotton or other Seed; and I do hereby declare that the following is a full, clear, and exact description of the construction and operation of the same, reference being had to the annexed drawings making a part of this specification, in which—

Figure 1 is a longitudinal section and elevation; and Figure 2, a transverse section of the revolving cylinder.

To enable others skilled in the art to make and use my invention, I will proceed to describe its construction and operation, by the aid of the drawings and letters of reference marked thereon.

A is the revolving cylinder, which is usually made of cast-iron, through which a spindle is inserted to form its axis.

B B are grooves cut out the length of the cylinder.

C O are steel knives.

D D are the backers.

F F are the regulators.

The height or set of the knives is regulated by the adjusting-screws E E.

The bolts G G hold the backers and regulators firmly to the cylinder.

The operation of my invention will now be readily understood. The steel knives C C are placed in the regulators; then the adjusting-screws E E are set so as to raise the edges of the knives to any required set. The regulators are then placed in the grooves B B of the cylinder, the backers are inserted, and the bolts G G are screwed tight, thus firmly holding the knives. The cylinder is now ready for use.

I do not confine myself to the precise forms of the parts which I have represented. I may dispense with

the regulators F F, and screw bolts into the cylinder, having collars or nuts, between which an eye having a point to project into the knives may be inserted, which will raise and lower the knives C C; or the same device may be applied to the regulators F F or backers D D; or the knife may be raised by means of inclined planes or wedges or eccentric-headed pins; or I may insert tapped eyes into the knives, and by means of bolts from outside the cylinder raise or lower the knives.

Some of the advantages due to my improvements may be enumerated as follows:

First. The facility with which any amount of set can be given to the knives.

Second. The ease and rapidity with which the knives can be changed.

Third. In practice one end of the knives is worn away more than the other. By my improved adjustment the worn end can be raised to the proper set.

Fourth. The knives can be properly sharpened and set in the regulators away from the hulling-machine.

I do not claim as new a backer holding a steel knife by means of pins in the revolving cylinder of a hulling-machine, as I am aware this has been done before.

Having now fully described my invention,

What I claim as new, and desire to secure by Letters Patent, is—

The arrangement of the regulators F F, backers D D, adjusting-screws E E, or their equivalents for regulating the set of the steel knives C C in hulling-cylinders, substantially and for the purpose described.

WILLIAM PORTER.

Witnesses:

W. ARTHUR, Junr.,

ALEX. T. ARTHUR.