

(19) World Intellectual Property Organization
International Bureau



(43) International Publication Date
1 February 2007 (01.02.2007)

PCT

(10) International Publication Number
WO 2007/012880 A1

- (51) International Patent Classification:
B65D 5/36 (2006.01)
- (21) International Application Number:
PCT/GB2006/002850
- (22) International Filing Date: 28 July 2006 (28.07.2006)
- (25) Filing Language: English
- (26) Publication Language: English
- (30) Priority Data:
0515677.3 29 July 2005 (29.07.2005) GB
0604490.3 6 March 2006 (06.03.2006) GB
- (71) Applicant (for all designated States except US): **COLPAC LIMITED** [GB/GB]; Enterprise Way, Maulden Road, Flitwick, Bedfordshire MK45 5BW (GB).
- (72) Inventors; and
- (75) Inventors/Applicants (for US only): **GOLDMAN, Neil** [GB/GB]; Enterprise Way, Maulden Road, Flitwick, Bedfordshire MK45 5BW (GB). **MILLS, Frank** [GB/GB]; Enterprise Way, Maulden Road, Flitwick, Bedfordshire MK45

- 5BW (GB). **WRIGHT, Philip** [GB/GB]; Enterprise Way, Maulden Road, Flitwick, Bedfordshire MK45 5BW (GB).
- (74) Agents: **GILL, Ian, Stephen** et al.; A A Thornton & Co, 235 High Holborn, London WC1V 7LE (GB).
- (81) Designated States (unless otherwise indicated, for every kind of national protection available): AE, AG, AL, AM, AT, AU, AZ, BA, BB, BG, BR, BW, BY, BZ, CA, CH, CN, CO, CR, CU, CZ, DE, DK, DM, DZ, EC, EE, EG, ES, FI, GB, GD, GE, GH, GM, HN, HR, HU, ID, IL, IN, IS, JP, KE, KG, KM, KN, KP, KR, KZ, LA, LC, LK, LR, LS, LT, LU, LV, LY, MA, MD, MG, MK, MN, MW, MX, MZ, NA, NG, NI, NO, NZ, OM, PG, PH, PL, PT, RO, RS, RU, SC, SD, SE, SG, SK, SL, SM, SY, TJ, TM, TN, TR, TT, TZ, UA, UG, US, UZ, VC, VN, ZA, ZM, ZW.
- (84) Designated States (unless otherwise indicated, for every kind of regional protection available): ARIPO (BW, GH, GM, KE, LS, MW, MZ, NA, SD, SL, SZ, TZ, UG, ZM, ZW), Eurasian (AM, AZ, BY, KG, KZ, MD, RU, TJ, TM), European (AT, BE, BG, CH, CY, CZ, DE, DK, EE, ES, FI, FR, GB, GR, HU, IE, IS, IT, LT, LU, LV, MC, NL, PL, PT,

[Continued on next page]

(54) Title: A CONTAINER FOR FOOD

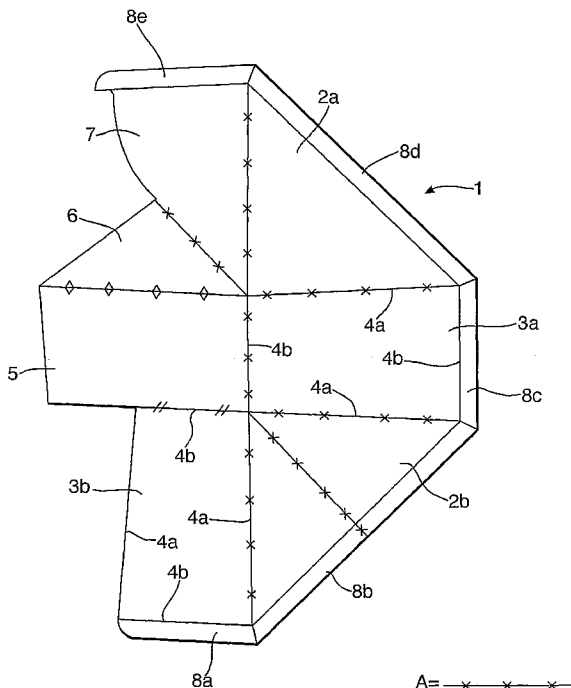

(57) Abstract: A container for receiving a food product is formed from a shaped blank of paper, paperboard, cardboard or a similar material. A hinge arrangement comprising at least two and preferably three parts is provided between one of the side walls and one of the end walls to allow the partially formed container to be moved easily between a flat configuration suitable for transportation or storage and an erect configuration for receiving a food product. In the erect configuration one part of the hinge arrangement is sandwiched between another part of hinge arrangement and the end wall. In the flat configuration these two parts of the hinge arrangement lie in substantially the same plane. An integral lid may be provided.

WO 2007/012880 A1



RO, SE, SI, SK, TR), OAPI (BF, BJ, CF, CG, CI, CM, GA, GN, GQ, GW, ML, MR, NE, SN, TD, TG).

For two-letter codes and other abbreviations, refer to the "Guidance Notes on Codes and Abbreviations" appearing at the beginning of each regular issue of the PCT Gazette.

Published:

— *with international search report*

A CONTAINER FOR FOOD

This invention relates to a container for receiving a food product and in particular the invention is concerned with containers that can be formed by folding a shaped
5 blank of paper, paperboard, cardboard or a similar material.

This invention provides a partially assembled container for receiving a food product and formed from a blank, the container having triangular side walls and substantially rectangular end walls to enable the formation of a generally triangular prism-shaped container with an opening for receiving the food product, wherein hinge
10 means comprising a first hinge part hingedly connected to a second hinge part are provided between one of said side walls and one of said end walls to enable the partially assembled container to be moved between a substantially flat position for storage and transportation and a substantially erect position for receiving a food product.

15 This novel container construction provides a partially formed container that has a number of advantages over known constructions. In particular it can be moved quickly and easily between a flat configuration to an erect configuration without the need for tabs or tongues to be inserted in pre-cut slots or additional gluing. The container "pops up" from the flat configuration to the erect configuration when the sides of the flat
20 container are pulled apart. Also, the partially formed container makes very efficient use of the blank material, thereby decreasing costs. Further, the partially formed container can be transported in the flat condition, and then erected easily by the food producer.

In one embodiment the first hinge part is hingedly connected to said one side wall, and the second hinge part is rigidly connected to said one end wall. The first and
25 second hinge parts lie in substantially the same plane when the container is in a substantially flat condition, and the first hinge part and said one end wall sandwich the second hinge part when the container is in a substantially erect condition.

In another embodiment the hinge means additionally comprises a third hinge part hingedly connected to the second hinge part and rigidly connected to the said end
30 wall. Preferably, the third hinge part is hingedly connected to the second hinge part and rigidly connected to the said end wall such that the said end wall is sandwiched by the second and third hinge parts. In a first preferable alternative, the third hinge part is hingedly connected to the second hinge part and rigidly connected to the said end wall

such that the said third hinge part is sandwiched by the end wall and the second hinge part. In a second preferable alternative, the third hinge part is hingedly connected to the second hinge part and rigidly connected to the said end wall, and the first hinge part is securely fastened to one of said triangular side walls when the container is in its substantially erect position provision.

The provision of the third hinge part complicates the construction of the container slightly, but its provision is advantageous because it improves the integrity of the seal between the second hinge part and the said end wall to improve the shelf life of the food product contained in the finished container.

The third hinge part and the surface of the end wall to which it is connected may substantially congruent so that the third hinge part of the hinge means and the said end wall provide a basal surface for the container with double thickness. This double thickness basal surface helps to prevent or delay leakage for the contents of the food product from the container.

The hinge means are preferably integral with the said side wall. This feature simplifies the blank from which the partially formed container is constructed, and it helps to improve the integrity of the finished container.

The partially assembled container according to the first and second preferable alternatives is particularly suited to a relatively automated process where the container is opened by machinery provided for that purpose such that a food product can then be inserted manually or by further machinery, and this development is realised by adopting a two stage construction process in which:

- 1) the third hinge part is fastened to the said end wall and the partially fastened container is folded into a substantially flat configuration;
- 2) the partially fastened container is stored and transported to a food producer or user;
- 3) the partially fastened container is opened; and
- 4) the container is erected by bringing the hinge parts into abutment, or by securing the first hinge part to one of the triangular side walls and then securing the hinge parts in the abutting configuration.

The partially fastened container described in step (i) is suitable for transportation and storage prior to use. The partially fastened container can be folded quickly and easily by apparatus provided for that purpose and then the container can be secured in

its erect condition ready for receipt of a food product by fastening the first and second hinge parts as described in step (iii). The configuration of the partially formed container allows steps (ii) and (iii) to be accomplished at high production speeds on known forms of folding and fastening apparatus, or apparatus of that type with simple and inexpensive modifications. These benefits are achieved because the partially fastened container lies flat, making it easier for the machinery to pick and denest it.

It is preferred in the first preferable alternative that the third hinge part is secured to the inner face of the end wall, such that the end wall and the first hinge part sandwich the second and third hinge parts. In this configuration the sandwich pack provides four blank external faces and this simplifies printing onto those external surfaces with advertising, nutritional information or other matter.

Overall the combination of these features allow a container to be formed from a blank with very minimal scoring of the joints to provide a good shelf life performance, and also enable the partially assembled container to be made up easily into a flat configuration for transportation and storage and opened equally easily into an erect configuration for insertion of a food product. The preferred three part hinge arrangement provides an excellent seal and extended shelf life for the food product, but a two part hinge arrangement would also be possible and might be used where the shelf life of the food product is not a crucial factor.

The present invention also provides a blank for forming a container for receiving a food product, the blank having triangular side walls and substantially rectangular end walls to enable the formation a generally triangular prism-shaped container with an opening for receiving the food product, the blank further comprising hinge means, the hinge means comprising a first hinge part hingedly connected to a second hinge part and arranged between one of said side walls and one of said end walls to enable a partially assembled container formed from the blank to be moved between a substantially flat position for storage and transportation and a substantially erect position for receiving a food product.

A clear understanding of the present invention will be gained from the following detailed description, given by way of example only, with reference to the accompanying drawings, in which:

Figure 1 is a plan view of a container according to the invention;

Figures 2 and 3 are plan views of the blank in an intermediate stage of

construction;

Figure 4 is a plan view of a partially assembled container in a flat configuration;

Figures 5 and 6 are perspective views of a partially assembled container between a flat configuration and an erect configuration;

5 Figures 7 and 8 are perspective views of a partially assembled container in an erect configuration;

Figure 9 is an underside view of the partially assembled container of Figures 7 and 8;

10 Figure 10 is a plan view of a blank according to a second embodiment of the invention with an integral lid;

Figures 11 and 12 are perspective and underside views respectively of the blank shown in Figure 10 assembled into a container, with Figure 11 showing the lid open and Figure 12 showing the lid closed.

Figure 13 is a plan view of a container according to third embodiment ;

15 Figures 14, 15 and 16 are views of the blank shown in Figure 13 in an intermediate stage of construction;

Figure 17 is a perspective view of a partially assembled container in an erect configuration;

Figure 18 is a plan view of a container according to a fourth embodiment;

20 Figures 19, 20 and 21 are views of the blank shown in Figure 18 in an intermediate stage of construction; and

Figure 22 is a perspective view of a partially assembled container in an erect configuration.

25 The container blank or skillet shown in Figure 1, and generally designated 1, may consist of paper, paperboard, cardboard or a similar material. A pair of congruent isosceles-shaped side walls 2a and 2b are alternately arranged with and hingedly connected to generally rectangular end walls 3a and 3b. (The end walls may be rectangular, but they are preferably trapezoidal so that in the fully assembled container they taper inwardly towards an apex to allow a number of assembled containers to be 30 stacked together.)

The end walls have opposed major and minor edges, designated 4a and 4b respectively. Both of the major edges 4a of the end walls 3a are flanked by the congruent edges of the side walls 2a and 2b. Side wall 3b has one of its major edges

4a integrally formed with a congruent edge of side wall 2b.

A hinge arrangement integrally formed with side wall 2a has three parts: generally rhombic flap or tab 5; a triangular central part or panel 6; and a three sided part or panel 7. These three parts are integrally formed and connected by fold lines.

5 Panel 7 is integrally formed with side wall 2a. The flap 5 is hingedly connected to the minor edge 4a of end wall 3a and this hinge point forms the apex of the finished triangular prism-shaped container.

All of the connecting lines shown in Figure 1 represent valley or hill folds with valley folds shown with icon A and hill folds shown with icon B. Icon C shown between
10 flap 5 and end wall 3a represent a cut line.

Oral flaps or tabs 8a to 8e formed with side walls 2, the end walls and the panel 7 cooperate in the assembled container to define a flange which is surrounds the mouth
9 of the container.

Turning now to Figure 2, the hinge arrangement 5,6,7 is folded to overlies the
15 side and end walls 2a, 3a. End wall 3b is then brought into abutment with the exposed surfaces of the flap 5 by folding the side wall 2b about its central fold line as shown in Figure 3. The abutting surfaces of the flap 5 and the end wall 3b, both designated as S1 in Figure 2, are glued together to form a permanent join. These surfaces S1 are substantially (but not completely) congruent to form a double thickness wall. This
20 double thickness wall can be used as the base on the finished container to provide addition resistance against the egress of the food product housed within the container.

As shown in Figure 3, the blank is further folded about the join between the tab 5 and the central panel 6 to bring part of the end wall 3b into abutment with the exposed surface of the central panel 6. The abutting surfaces of the first element 6 and the end
25 wall 3b, both designated as S2 in Figure 3, are glued together to form a permanent join and thereby sandwich part of the end wall 3b between the flap 5 and the central panel 6. The resultant partially formed container is shown in Figure 4, and this configuration represents the partially formed container in its flat configuration.

The configuration of the container means that when it is opened by, say, pulling
30 the side walls 2a and 2b in opposite directions, the container naturally opens out into an erect configuration ready for receiving a food product, such as a sandwich. The movement of the container between the flat configuration shown in Figure 4 and the erect configuration shown in Figure 7 is depicted, as far as it is possible to do so, in

Figures 5 and 6.

In the erect configuration the panel 7 and the end wall 3b sandwich the central panel 6, and the container can be fixed in a fully formed configuration by permanently joining the abutting parts of these panels 6,7. Alternatively, or in addition, part of the
5 panel 7 will abut the part of the end wall 3b and the container can be fixed in a fully formed condition by joining these abutting surfaces. In an alternative embodiment a catch or detent mechanism can be provided so that the partially assembled container can be mechanically fastened in an erect condition without the use of glue or other permanent fastening.

10 The oral flanges 8a and 8e overlap in the erect configuration and these may also be glued or otherwise fastened together. Alternatively one of these flanges could be omitted from the blank.

The preferred embodiment of the invention, which is depicted in Figures 1 to 9 and described above, has a hinge arrangement made up from three parts. However, it
15 will be apparent to a person skilled in the art that a two piece hinge arrangement made up from the panel 7 and the central panel 6 would function in the same manner. The use of the flap 5 is advantageous because it improves the integrity of the seal between the hinge arrangement and the end wall 3b, and it also provides a double thickness basal surface in the finished container, but if the shelf life of the food product does not
20 need to be maximised then the flap 5 could be omitted to reduce the amount of material used in the blank.

In the second embodiment shown in Figures 10, 11 and 12, and integral lid 10 is provided in place of the oral flap 8d adjacent side wall 2a. The lid is used to close the opening 9 in the finished container after the food product has been inserted. The lid 10
25 has an opening 11 which is covered by a transparent film 12 to enable the contents of the assembled container to be viewed after the peripheral end of the lid is sealed to the oral flange 8. The blank and container configuration allow the lid to be provided without a fold lines passing through the lid.

In the third and fourth embodiments shown in Figures 13 to 22, like parts are
30 numbered in the same sequence as the first and second embodiments, but the sequencing starts at 100 rather than at 1 in the third embodiment, and 200 in the fourth embodiment.

It should be noted that, in contrast to the first and second embodiments, the fold

line between the triangular central part or panel (106, 206) and the three sided part or panel (107, 207) in the third and fourth embodiments is a hill fold. This enables the hinge arrangement to be located internally in the erect container, and this modification could be applied to the first and second embodiments.

5 The construction of the third and fourth embodiments of the container involve the same steps, but the containers of these developments are particularly suited to a "pick and place" arrangement where the container is stored and shipped in a flat pack form, and then the construction finished at the site of the food producer by opening the container and securing the hinge arrangement. This second stage in the construction
10 process of opening the container from a substantially flat condition and securing the hinge parts in secure abutment is well suited to automation. The hinge parts can be secured by an appropriate means such as gluing, heat sealing or RF welding.

A food product such as a sandwich can then be placed in the erected container by hand or by apparatus designed for that purpose, and the opening to the container
15 closed and seal with a lid or suitable covering.

In the third embodiment, the hinge parts and the end wall provide a quadruple layer of paperboard, and this can be used as the base of the container to stop or slow down the egress of any moisture or liquid that might be contained in the sandwich. Also the construction of this development allows the hinge parts to lie within the
20 container leaving four blank panels on which marketing information can be placed.

In the fourth embodiment, the hinge parts also lie within the container leaving four blank panels on which marketing information can be placed.

The invention is not restricted to the embodiments of the invention explicitly described herein, and modifications within the scope of the invention described in the
25 claims will be apparent to the person skilled in the art. For example, references to sections of the blank being glued should be understood to encompass any form of fastening including RF welded by application of a suitable coating to the surfaces that are being joined.

Claims:

1. A partially assembled container for receiving a food product and formed from a blank, the container having triangular side walls and substantially rectangular end walls
5 to enable the formation a generally triangular prism-shaped container with an opening for receiving the food product, wherein hinge means comprising a first hinge part hingedly connected to a second hinge part are provided between one of said side walls and one of said end walls to enable the partially assembled container to be moved
10 between a substantially flat position for storage and transportation and a substantially erect position for receiving a food product.

2. A partially assembled container as claimed in claim 1, wherein the first hinge part is hingedly connected to said one side wall, and the second hinge part is rigidly connected to said one end wall.

15

3. A partially assembled container as claimed in claim 2, wherein the first and second hinge parts lie in substantially the same plane when the container is in a substantial flat condition, and the first hinge part and said one end wall sandwich the second hinge part when the container is in a substantially erect condition.

20

4. A partially assembled container as claimed in claim 1, 2 or 3, wherein the hinge means additionally comprises a third hinge part hingedly connected to the second hinge part and rigidly connected to the said end wall such that the said end wall is sandwiched by the second and third hinge parts.

25

5. A partially assembled container as claimed in claim 1, 2 or 3, wherein the hinge means additionally comprises a third hinge part hingedly connected to the second hinge part and rigidly connected to the said end wall such that the said third hinge part is sandwiched by the end wall and the second hinge part.

30

6. A partially assembled container as claimed in claim 1, 2 or 3, wherein the hinge means additionally comprises a third hinge part hingedly connected to the second hinge part and rigidly connected to the said end wall, the third hinge part is hingedly

connected to the second hinge part and rigidly connected to the said end wall, and the first hinge part is securely fastened to one of said triangular side walls when the container is in its substantially erect position provision.

5 7. A partially assembled container as claimed in any of claims 4 to 6, wherein the third hinge part and the surface of the end wall to which it is connected are substantially congruent.

8. A partially assembled container as claimed in any one of the preceding claims,
10 wherein the hinge means are integral with the said side wall.

9. A partially assembled container as claimed in any one of the preceding claims, wherein an integrally formed lid is provided for covering the opening in the container when it is in its erect condition.

15

10. A blank for forming a container for receiving a food product, the blank having triangular side walls and substantially rectangular end walls to enable the formation a generally triangular prism-shaped container with an opening for receiving the food product, the blank further comprising hinge means, the hinge means comprising a first
20 hinge part hingedly connected to a second hinge part and arranged between one of said side walls and one of said end walls to enable a partially assembled container formed from the blank to be moved between a substantially flat position for storage and transportation and a substantially erect position for receiving a food product.

25 11. A blank as claimed in claim 10, wherein the first hinge part is hingedly connected to said one side wall.

12. A blank as claimed in claim 10 or 11, wherein the hinge means additionally comprises a third hinge part hingedly connected to the second hinge part.

30

13. A blank as claimed in claim 12, wherein the third hinge part and the said end wall are substantially congruent.

14. A blank as claimed in claim 13, wherein the hinge means are integral with the said side wall.
- 5 15. A blank as claimed in any one of the claims 10 to 14, wherein an integrally formed lid is provided for covering the opening in the container when it is in its erect condition.
16. A partially assembled container for receiving a food product and formed from a
10 blank substantially as herein described with reference to the accompanying drawings.
17. A blank for forming a container for receiving a food product substantially as herein described with reference to the accompanying drawings.
- 15 18. A method of forming a container from a blank according to claim 10 or 11, the method comprising the following steps:
- 1) folding the hinge means to overlie at least the other of said side walls;
 - 2) bringing the one of said end walls into abutment with the other of said end walls by folding the other of said side walls about a central fold line thereof;
 - 20 3) gluing the abutting surfaces of the other of said end walls and the one of said end walls together to form a permanent join;
 - 4) folding the blank about the connection between the other of said end walls and the one of said side walls to bring part of the one of said end walls into abutment with the exposed surface of the second hinge part;
 - 25 5) gluing the abutting surfaces of the second hinge part and the one of said end walls together to form a permanent join;
 - 6) pulling the side walls in opposite directions such that the container naturally opens out into an erect state.
- 30 19. A method of forming a container from a blank according to claims 12 to 14, the method comprising the following steps:
- 1) folding the hinge means to overlie the other of said side walls and the other of said end walls;

- 2) bringing the one of said end walls into abutment with the exposed surfaces of the third hinge part by folding the other of said side walls about a central fold line thereof;
 - 3) gluing the abutting surfaces of the third hinge part and the one of said end walls glued together to form a permanent join;
 - 4) folding the blank about the connection between the third hinge part and the second hinge part to bring part of the one of said end walls into abutment with the exposed surface of the second hinge part;
 - 5) gluing the abutting surfaces of the second hinge part and the one of said end walls together to form a permanent join and thereby sandwich part of the one of said end walls between the third hinge part and the second hinge part;
 - 6) pulling the side walls in opposite directions, such that the container naturally opens out into an erect state.
20. A method of forming a container from a blank according to claims 12 to 14, the method comprising the following steps:
- 1) fastening the third hinge part to the inner surface of the one of said end walls and folding the partially fastened container into a substantially flat configuration;
 - 2) storing the partially fastened container and transporting it to a food producer;
 - 3) opening the partially fastened container;
 - 4) erecting the container by bringing the first and second hinge parts into abutment and fastening the hinge means in the abutting configuration ready for receipt of a food product.

Fig.1.

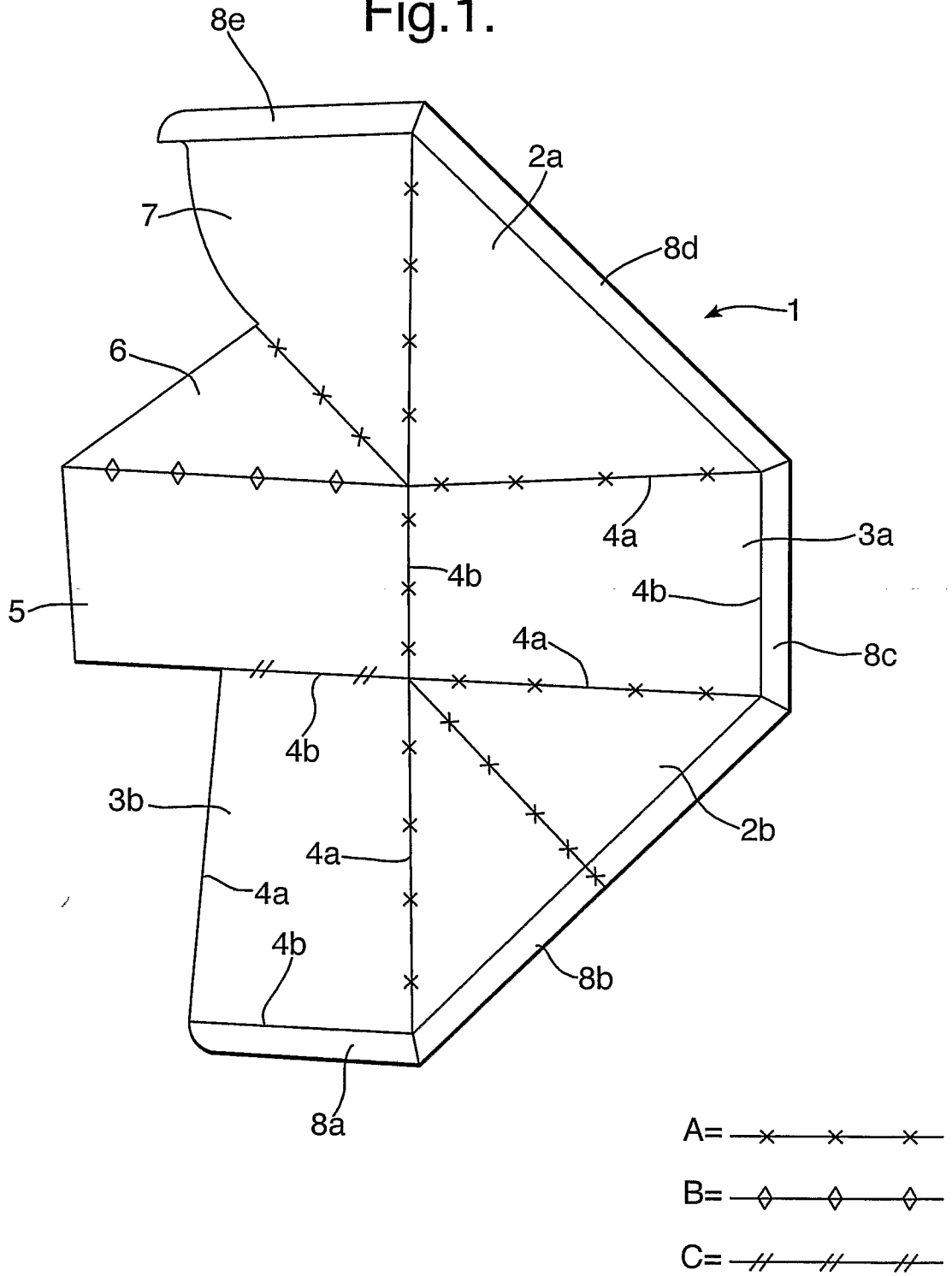

Fig.2.

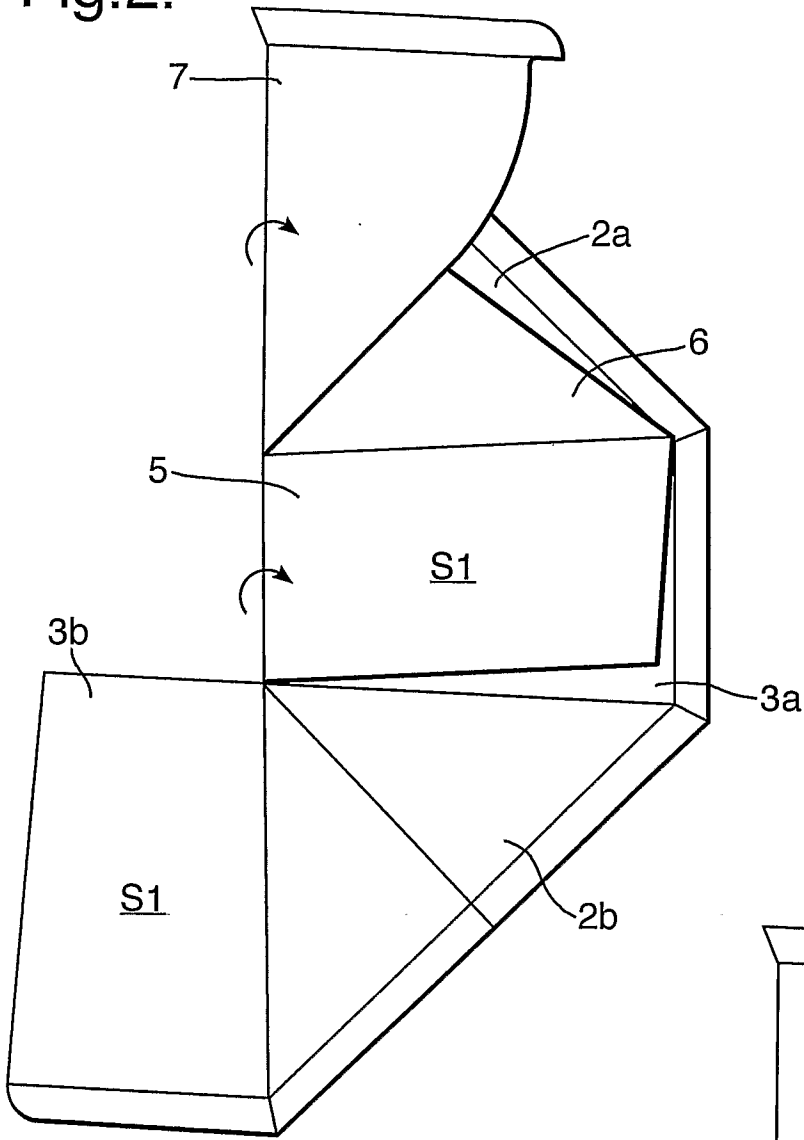

Fig.3.

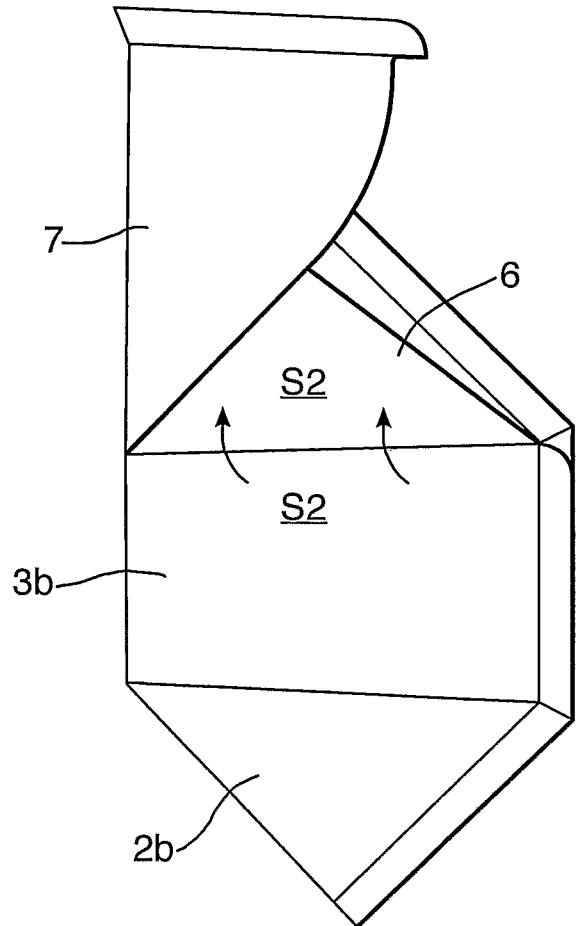

Fig.4.

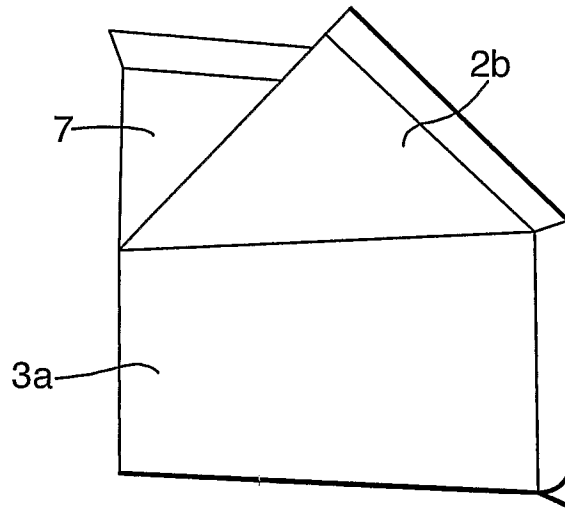

Fig.5.

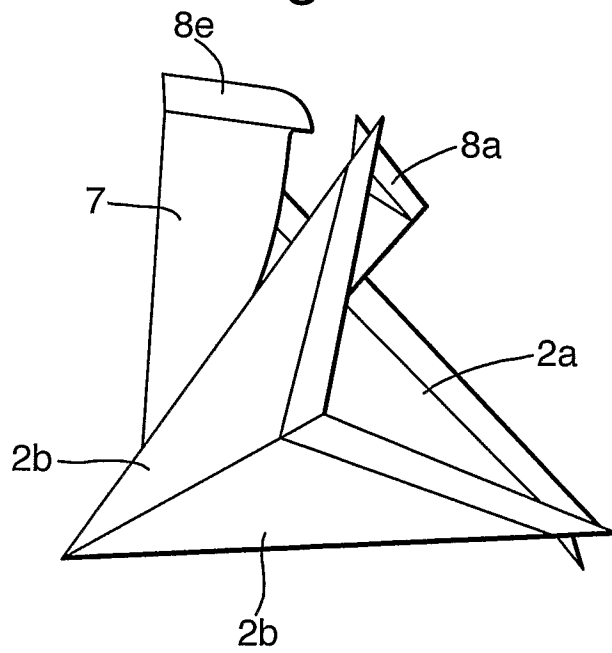

Fig.6.

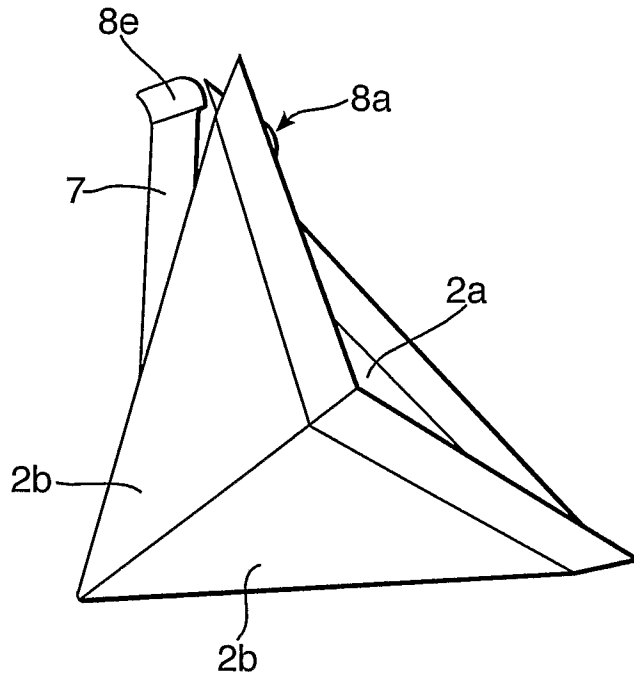

Fig.7.

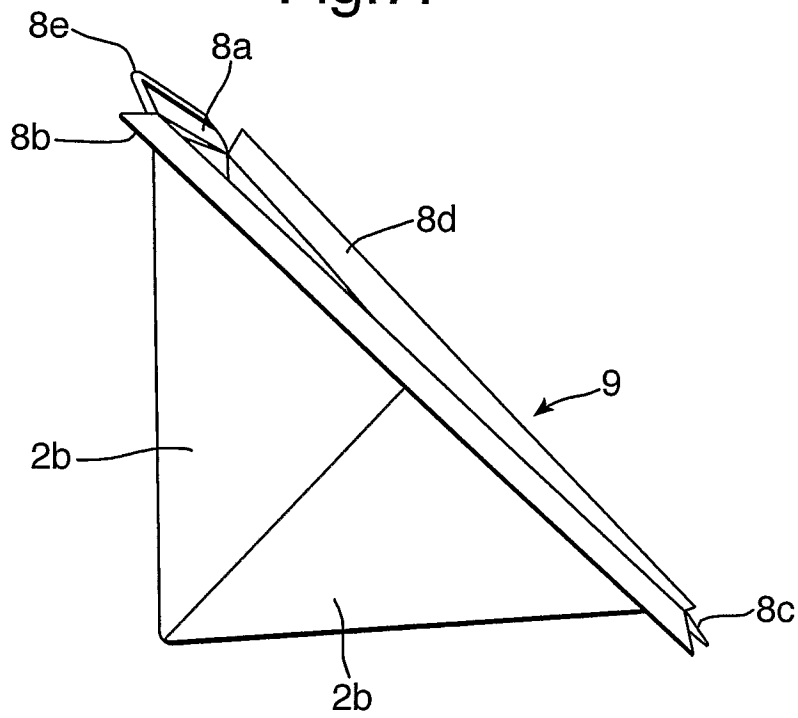

Fig.8.

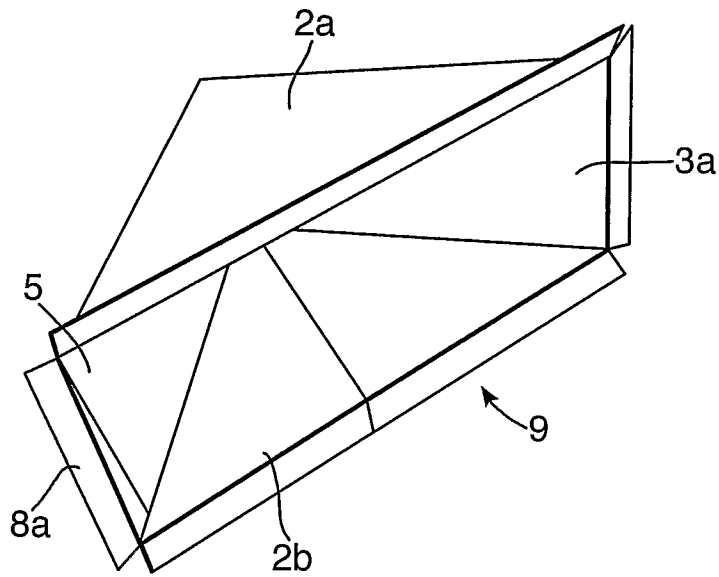

Fig.9.

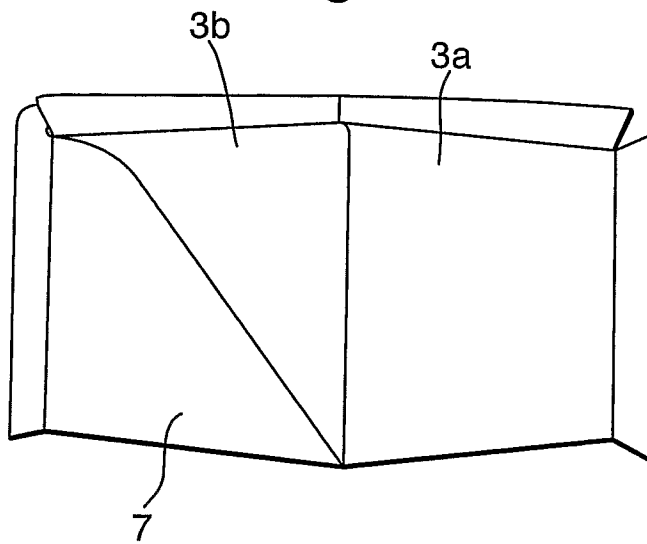

Fig.10.

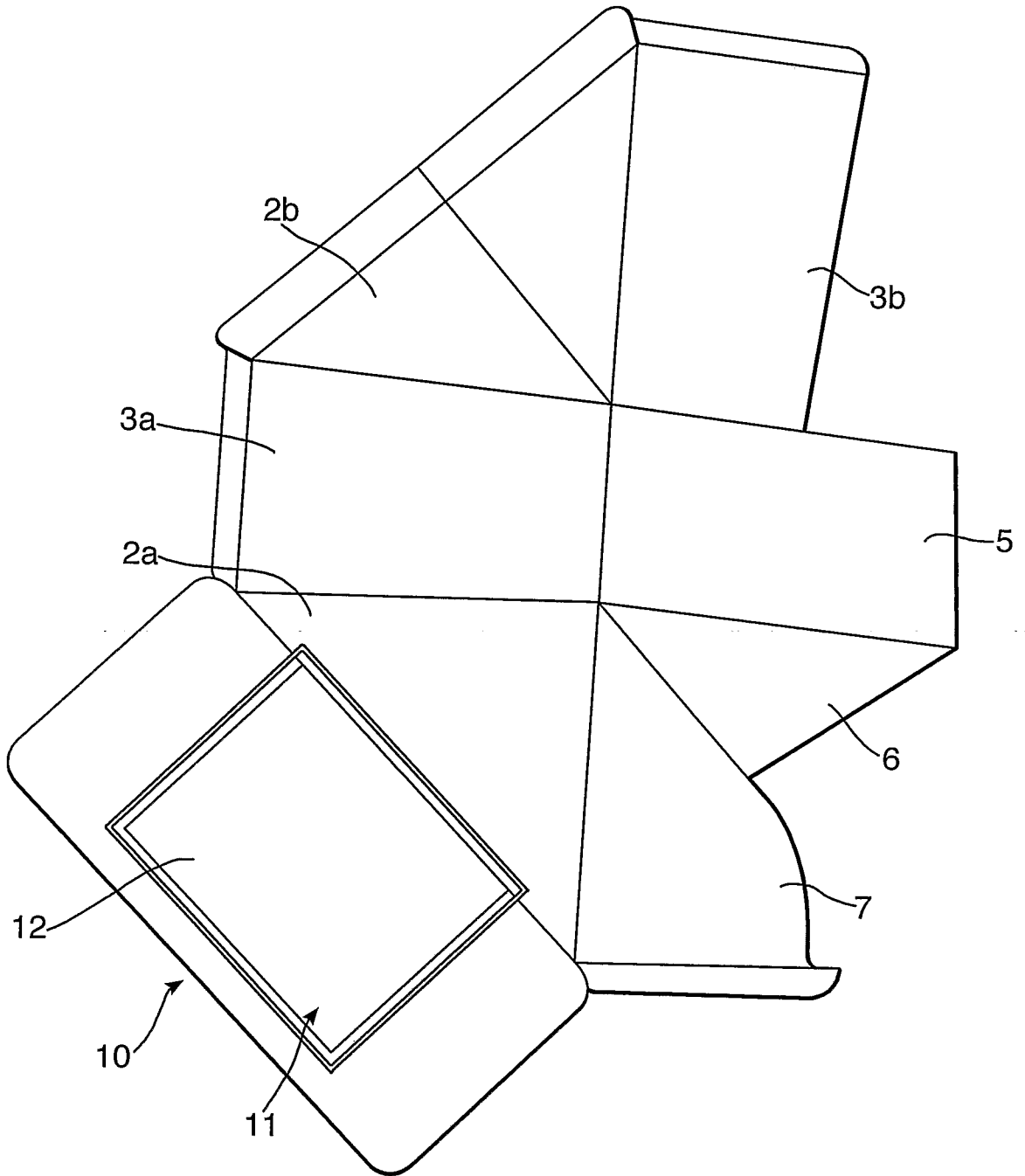

Fig.11.

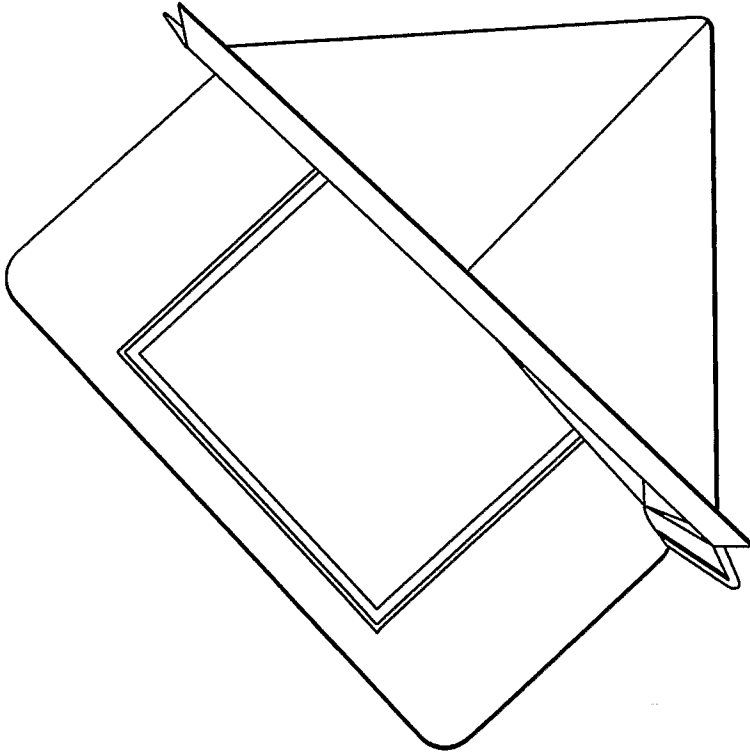

Fig.12.

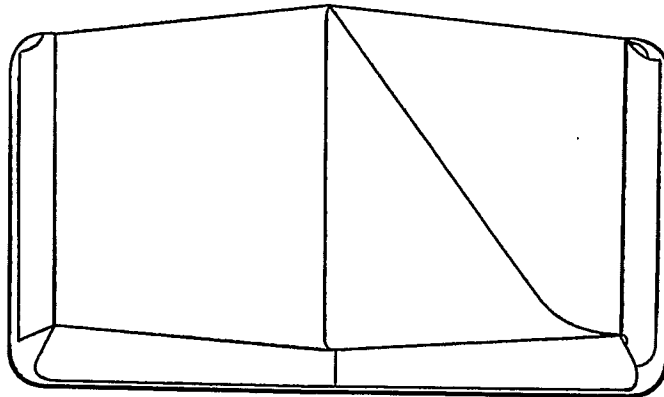

Fig.13.

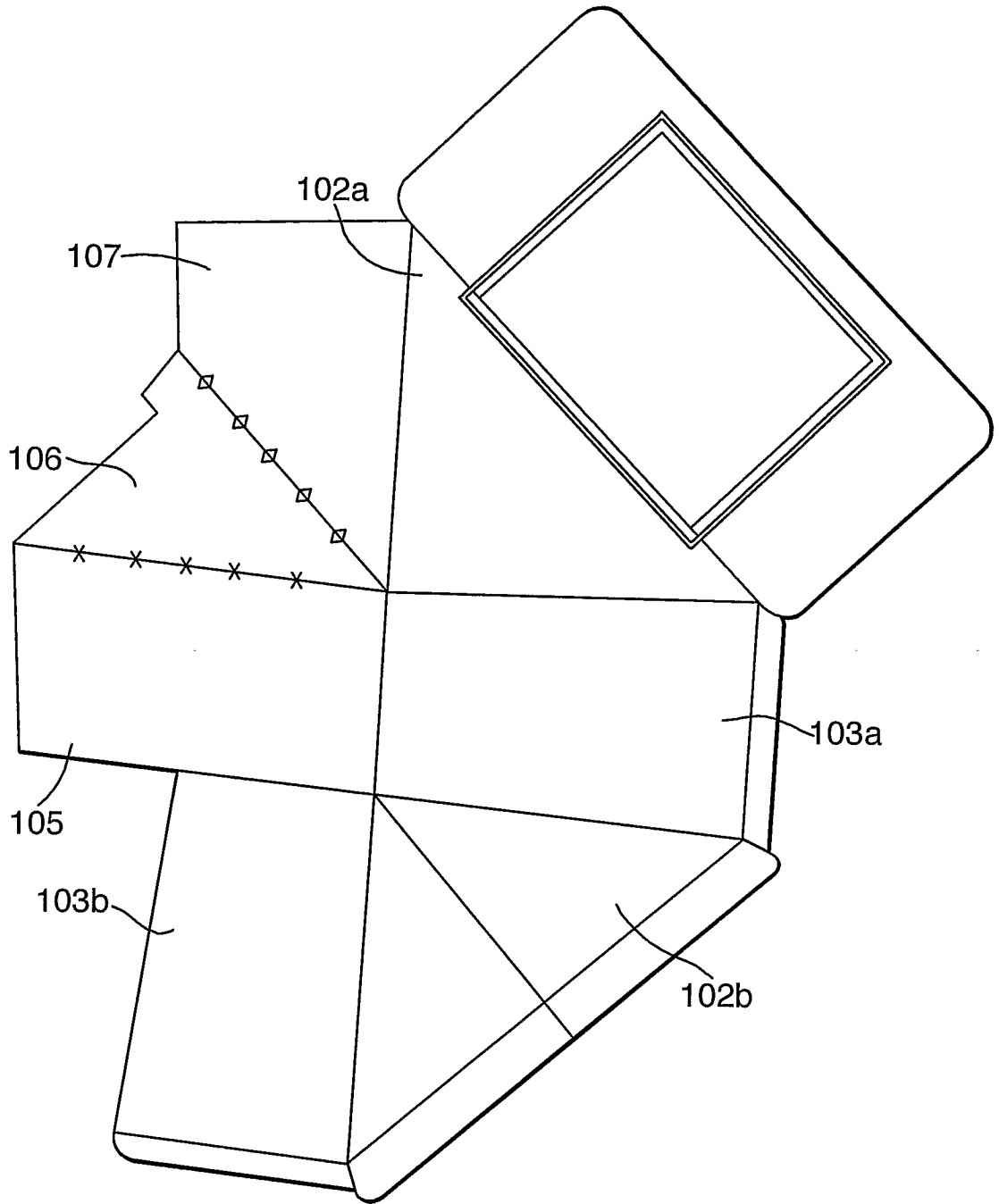

Fig.14.

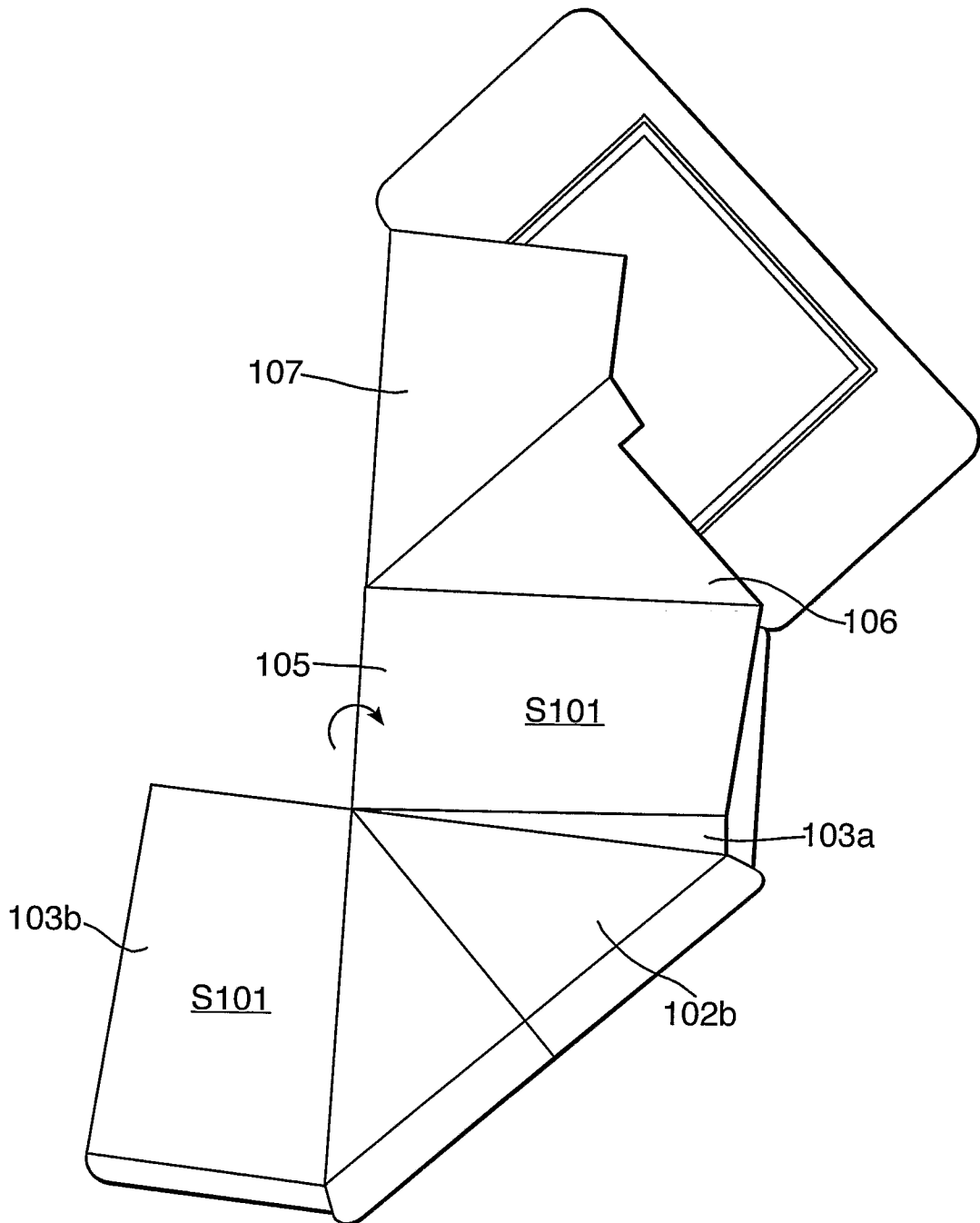

Fig.15.

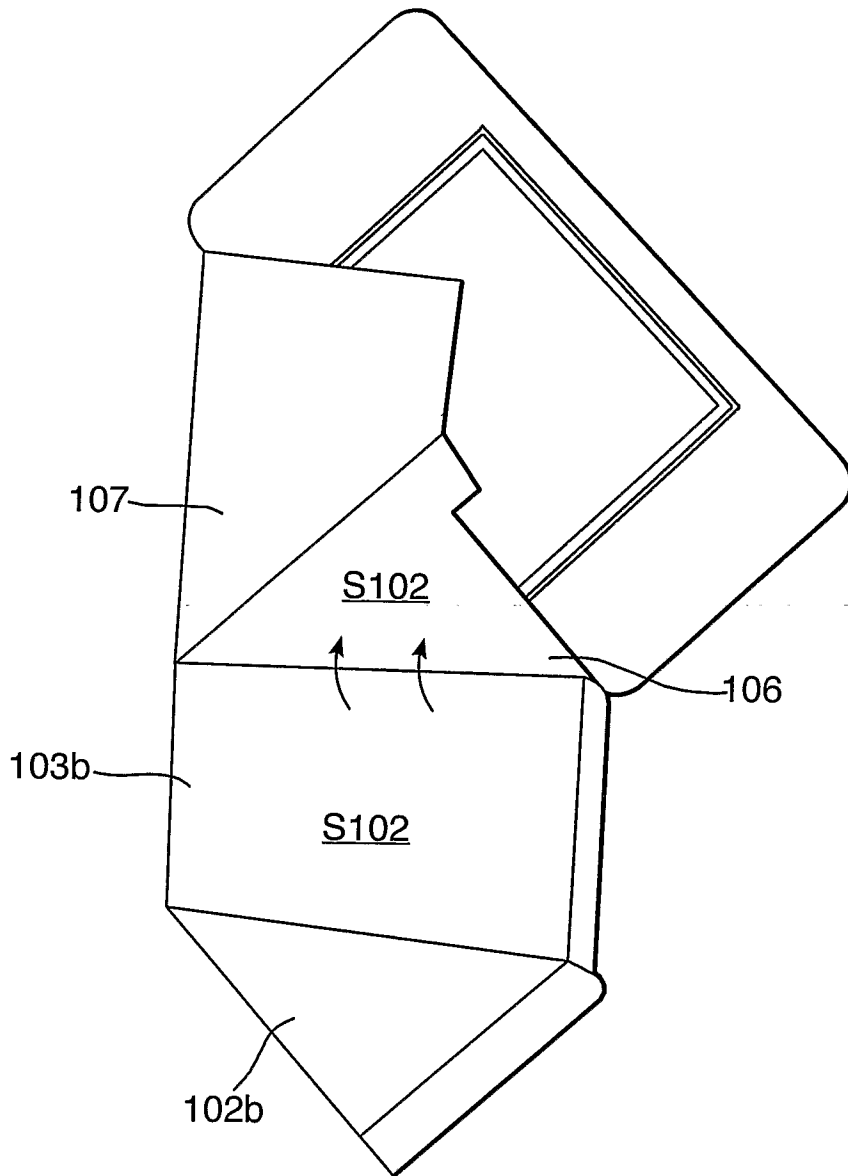

Fig.16.

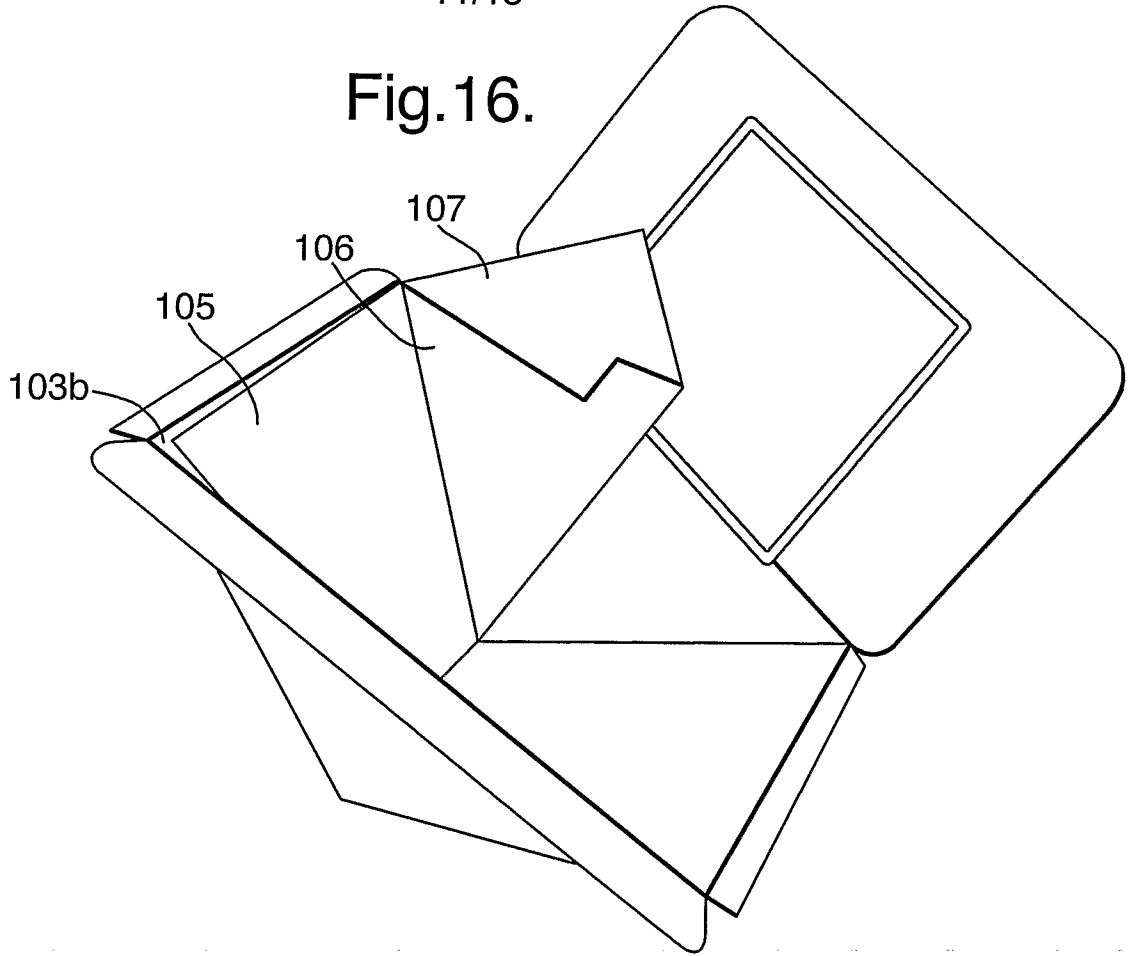

Fig.17.

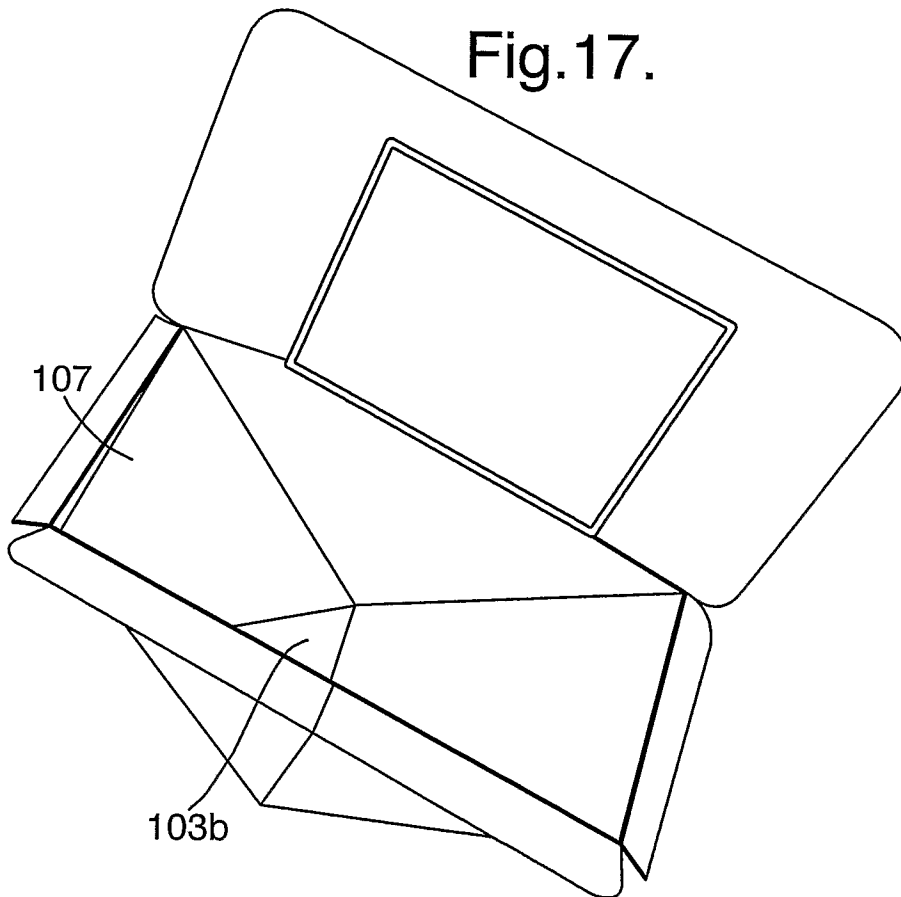

Fig.18.

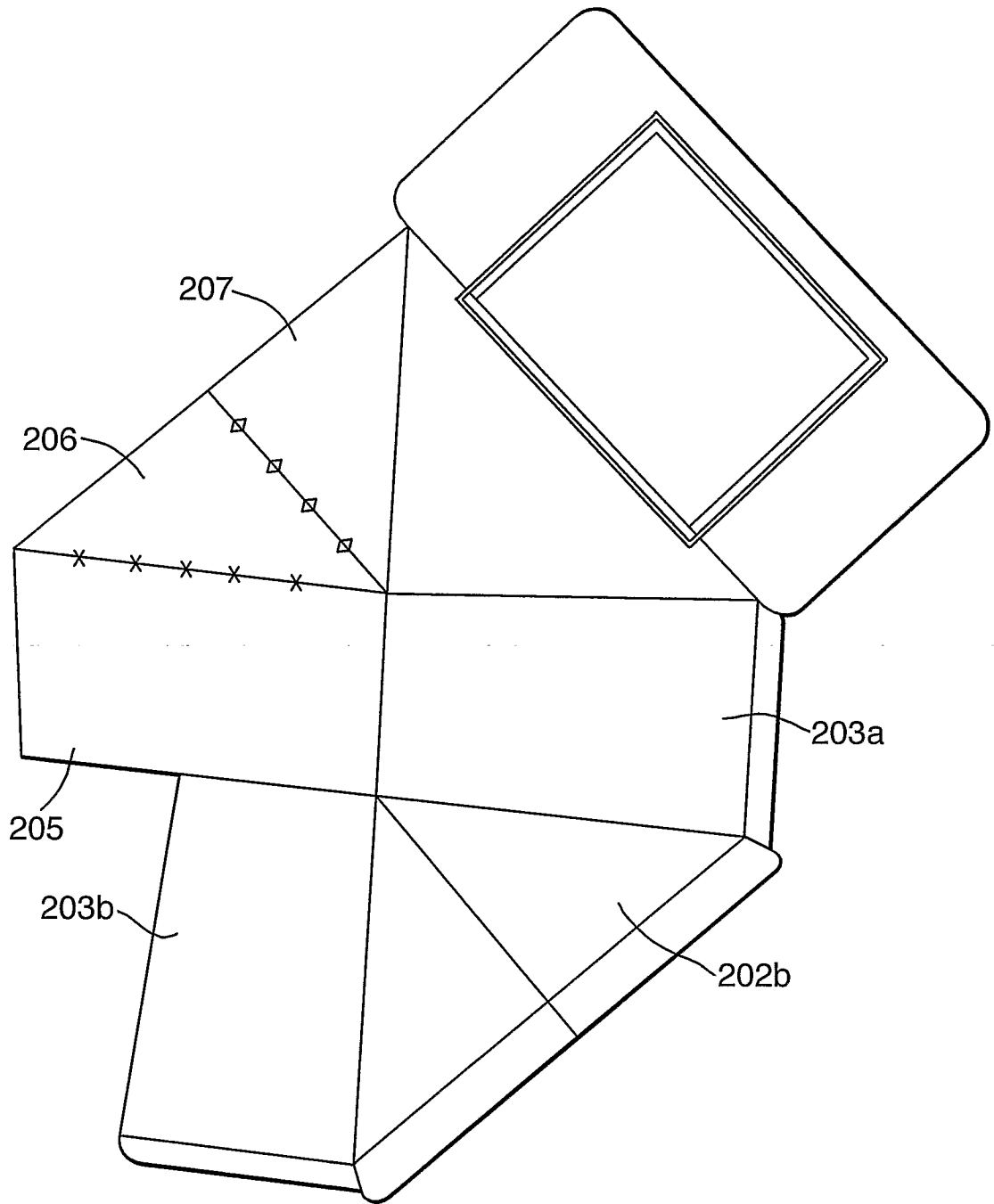

Fig.19.

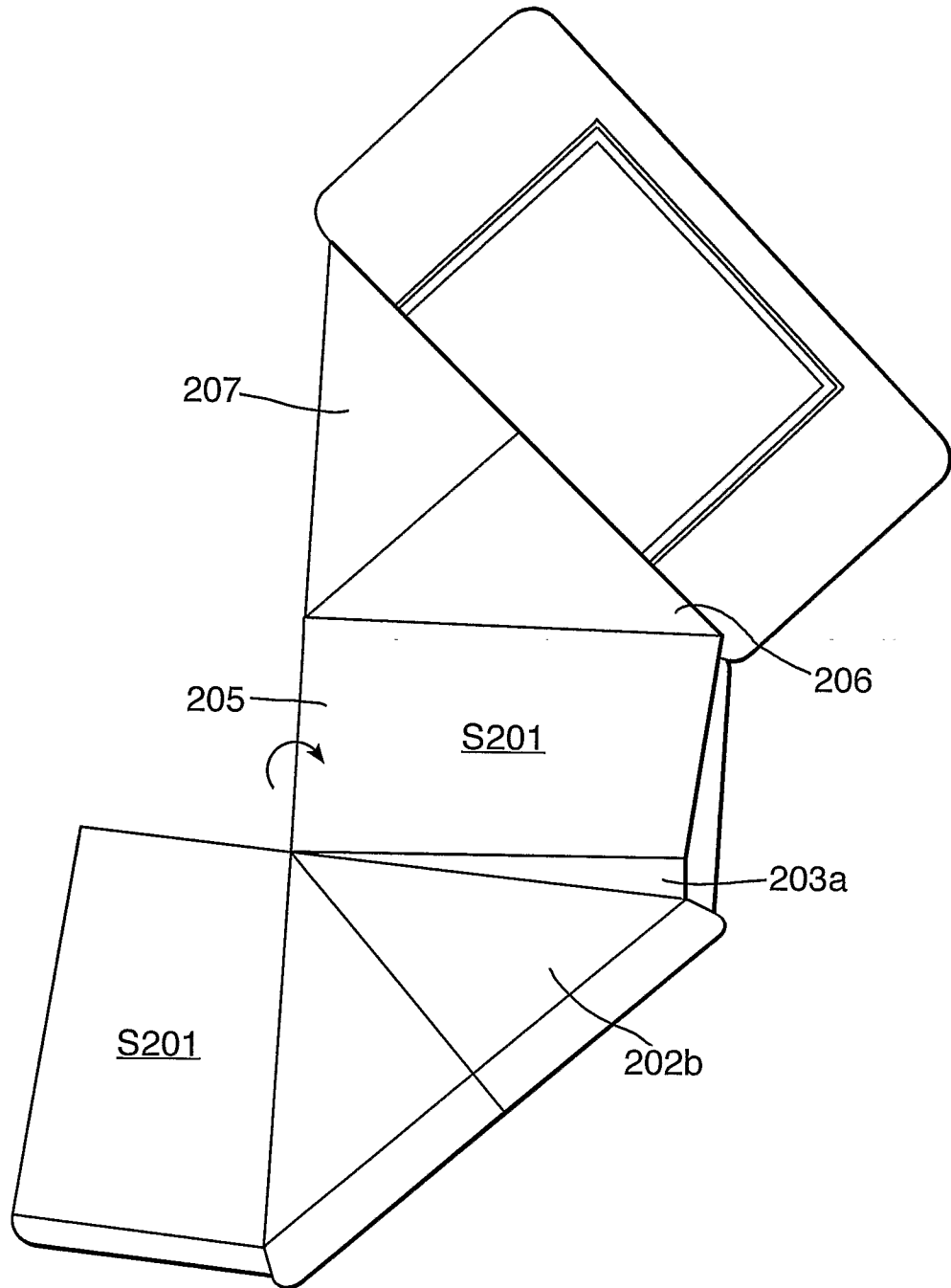
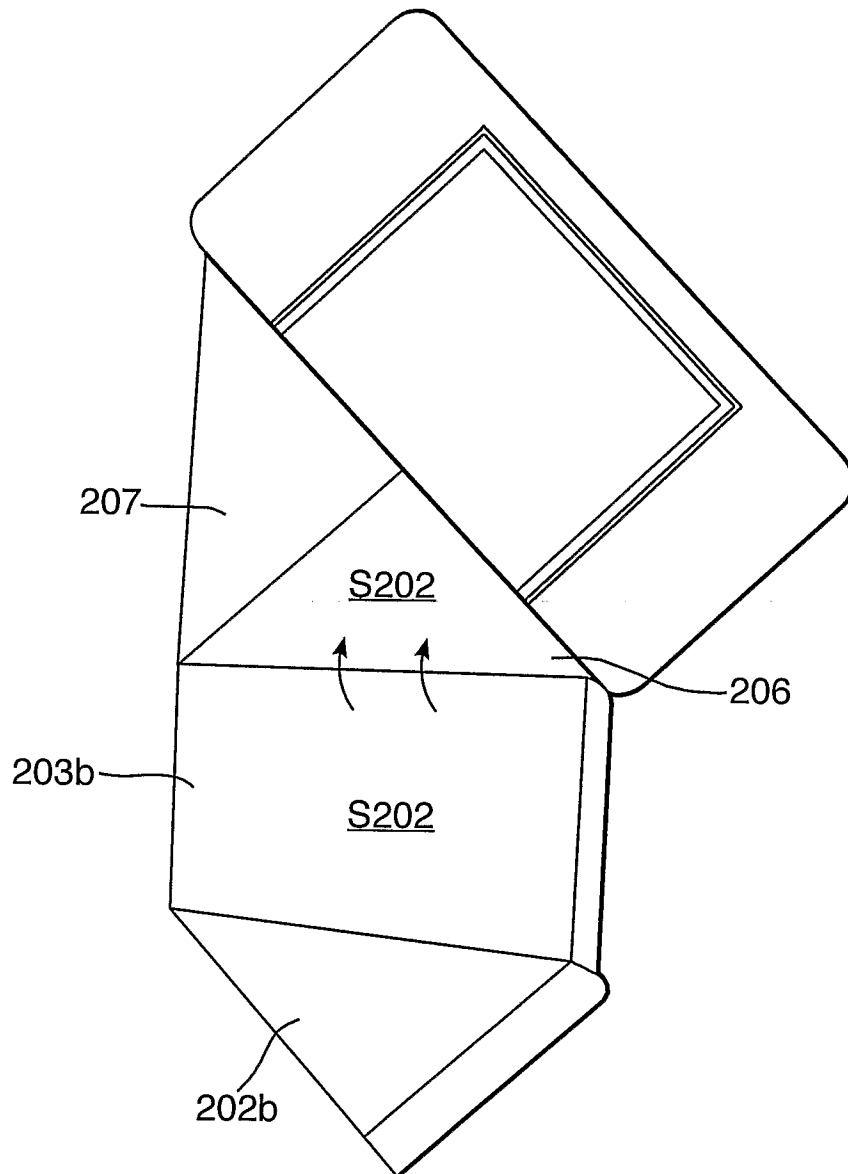

Fig.20.



15/15

Fig.21.

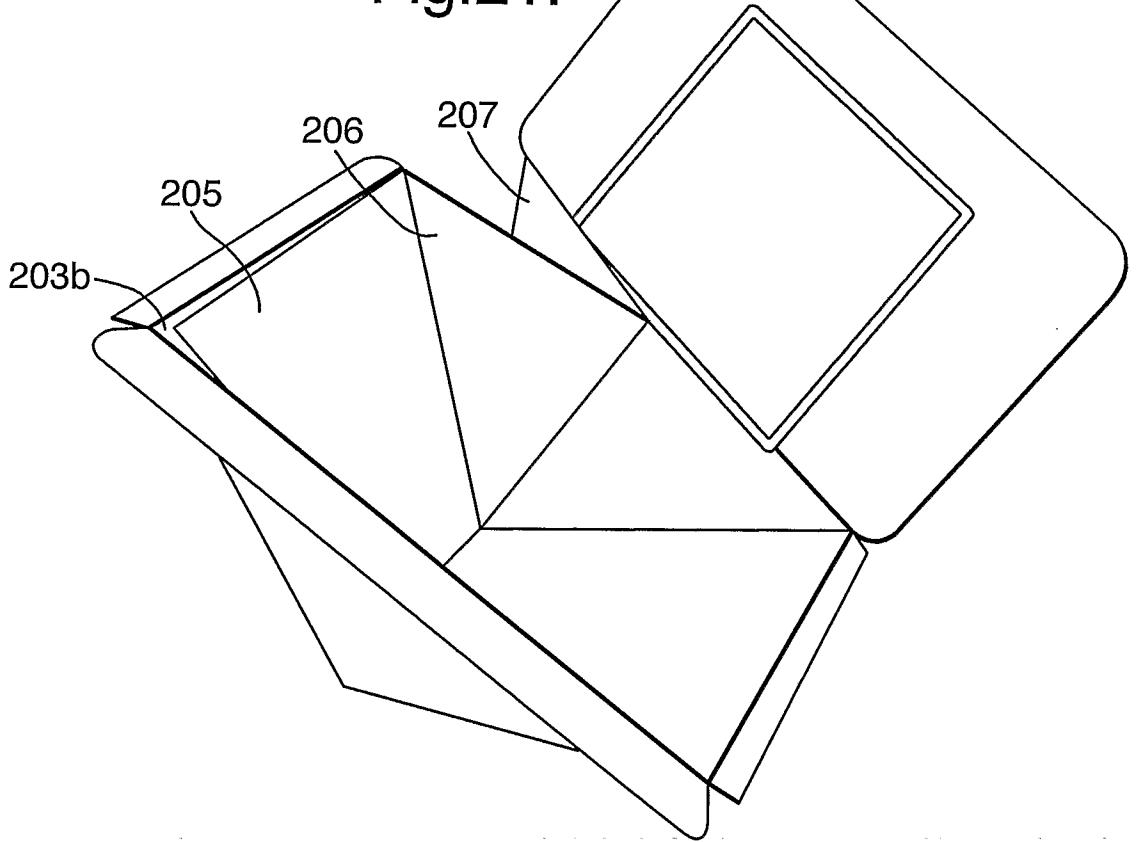
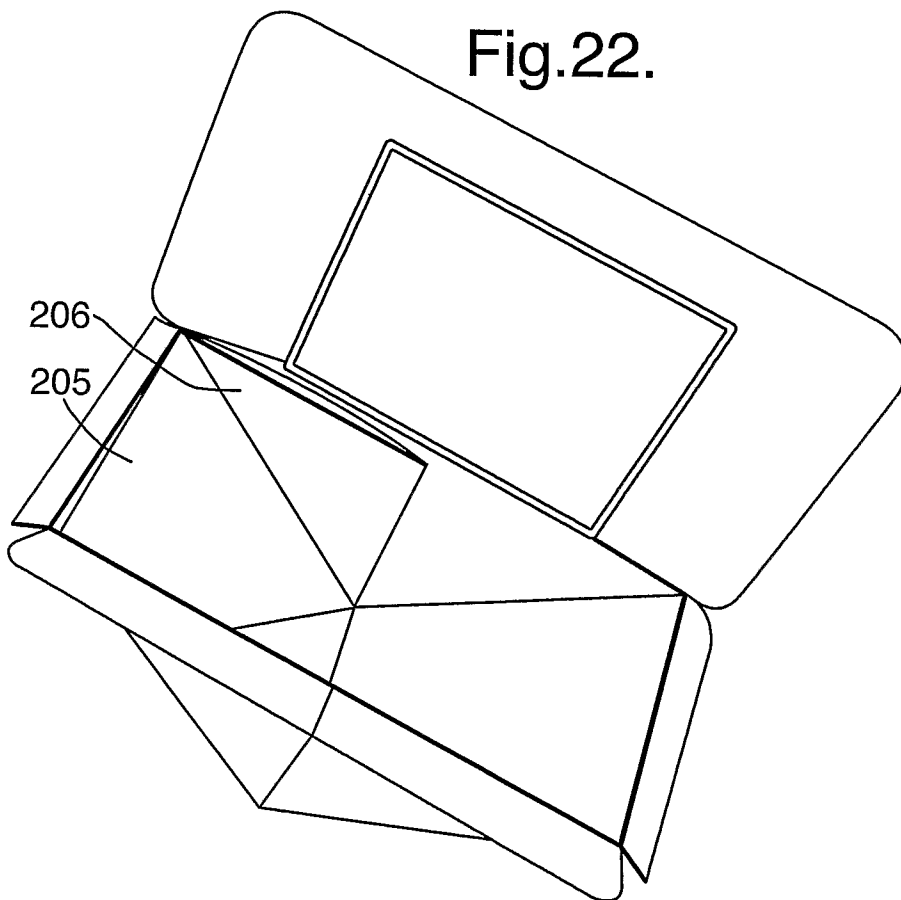

Fig.22.



INTERNATIONAL SEARCH REPORT

International application No
PCT/GB2006/002850

A. CLASSIFICATION OF SUBJECT MATTER INV. B65D5/36		
According to International Patent Classification (IPC) or to both national classification and IPC		
B. FIELDS SEARCHED		
Minimum documentation searched (classification system followed by classification symbols) B65D		
Documentation searched other than minimum documentation to the extent that such documents are included in the fields searched		
Electronic data base consulted during the international search (name of data base and, where practical, search terms used) EPO-Internal		
C. DOCUMENTS CONSIDERED TO BE RELEVANT		
Category*	Citation of document, with indication, where appropriate, of the relevant passages	Relevant to claim No.
X A Y Y	GB 2 398 557 A (DAVID * ROKOV; DAVID ROKOV) 25 August 2004 (2004-08-25) page 4, line 26 - page 8, line 8; figures 2,3 ----- GB 2 321 236 A (* COLPAC LIMITED) 22 July 1998 (1998-07-22) page 3 - page 5; figures 1-7 ----- DE 299 03 316 U1 (FRIEDRICH FREUND GMBH KARTONAGENFABRIK, 49124 GEORGS-MARIENHUETTE, DE) 12 May 1999 (1999-05-12) page 5, line 5 - page 6, line 31; figures 1-5 -----	1,2, 8-12,15 4-7,13, 14,16-20 1,3 1,3
<input type="checkbox"/> Further documents are listed in the continuation of Box C.		
<input checked="" type="checkbox"/> See patent family annex.		
* Special categories of cited documents :		
A document defining the general state of the art which is not considered to be of particular relevance *E* earlier document but published on or after the international filing date *L* document which may throw doubts on priority claim(s) or which is cited to establish the publication date of another citation or other special reason (as specified) *O* document referring to an oral disclosure, use, exhibition or other means *P* document published prior to the international filing date but later than the priority date claimed	*T* later document published after the international filing date or priority date and not in conflict with the application but cited to understand the principle or theory underlying the invention *X* document of particular relevance; the claimed invention cannot be considered novel or cannot be considered to involve an inventive step when the document is taken alone *Y* document of particular relevance; the claimed invention cannot be considered to involve an inventive step when the document is combined with one or more other such documents, such combination being obvious to a person skilled in the art. *&* document member of the same patent family	
Date of the actual completion of the international search <p style="text-align: center;">10 October 2006</p>	Date of mailing of the international search report <p style="text-align: center;">20/10/2006</p>	
Name and mailing address of the ISA/ European Patent Office, P.B. 5618 Patentlaan 2 NL - 2280 HV Rijswijk Tel. (+31-70) 340-2040, Tx. 31 651 epo nl, Fax: (+31-70) 340-3016	Authorized officer <p style="text-align: center;">Augustin, Wolfgang</p>	

INTERNATIONAL SEARCH REPORT

Information on patent family members

International application No
PCT/GB2006/002850

Patent document cited in search report	Publication date	Patent family member(s)	Publication date
GB 2398557	A	25-08-2004	NONE
GB 2321236	A	22-07-1998	NONE
DE 29903316	U1	12-05-1999	NONE