

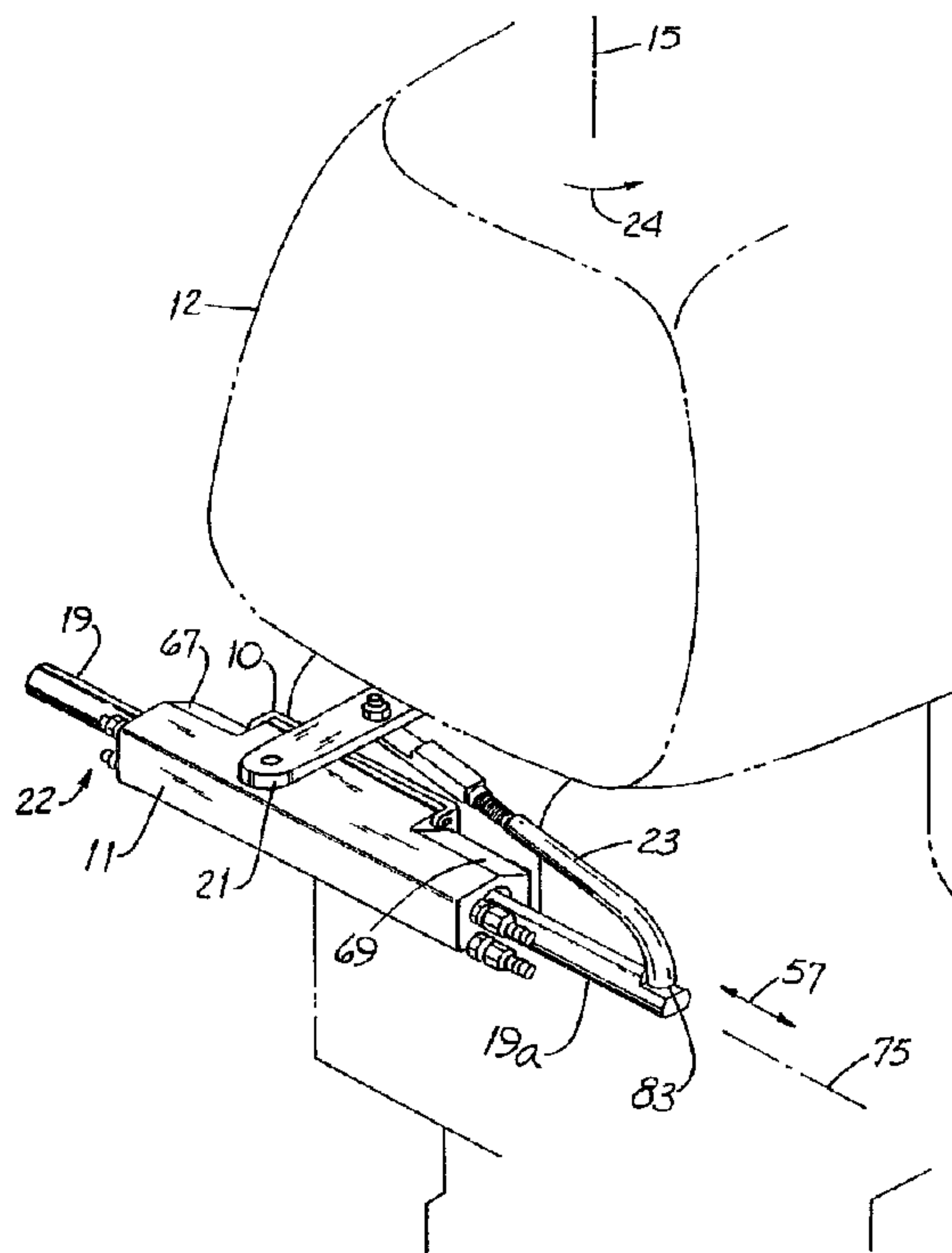

(86) Date de dépôt PCT/PCT Filing Date: 1996/08/30
 (87) Date publication PCT/PCT Publication Date: 1997/03/13
 (45) Date de délivrance/Issue Date: 2007/07/10
 (85) Entrée phase nationale/National Entry: 1998/02/24
 (86) N° demande PCT/PCT Application No.: US 1996/014962
 (87) N° publication PCT/PCT Publication No.: 1997/009232
 (30) Priorité/Priority: 1995/09/01 (US08/522,507)

(51) Cl.Int./Int.Cl. *B63H 20/12* (2006.01),
F02B 61/04 (2006.01)
 (72) Inventeur/Inventor:
WAGNER, JERALD G., US
 (73) Propriétaire/Owner:
TFX ACQUISITION, INC., US
 (74) Agent: ROBIC

(54) Titre : DISPOSITIF DE MONTAGE AMELIORE POUR VERIN DE DIRECTION DE MOTEUR
 (54) Title: IMPROVED MOUNTING ARRANGEMENT FOR ENGINE STEERING CYLINDER



(57) **Abrégé/Abstract:**

The new "universal" mounting bracket (10) is used to couple a hydraulic steering cylinder (11) to one of first and second brands of outboard engines (12). Such bracket (10) has first and second groups (25, 29) of holes (27, 31, respectively), the holes (27 or 31) comprising each group (25 or 29) positionally corresponding to a bracket attachment hole (43, 45) in the first or second brand of engine (12). The cylinder (11) has first and second spaced mounting faces (61, 63) that are angled with respect to a cylinder axis (75). The bracket (10) has first and second end members (59) contacting the first and second faces (61, 63), respectively. A mounting face (61 or 63) and its respective end member (59) are in compression when resisting steering force. The bracket (10) optionally includes at least one cutout area (49) (and preferably two or more cutout areas (49)) for fitting the bracket (10) around a Zerk fitting (51) on a particular brand or brands of engine (12).

PCTWORLD INTELLECTUAL PROPERTY ORGANIZATION
International Bureau

INTERNATIONAL APPLICATION PUBLISHED UNDER THE PATENT COOPERATION TREATY (PCT)

<p>(51) International Patent Classification ⁶ : B63H 5/12</p>	<p>A1</p>	<p>(11) International Publication Number: WO 97/09232</p> <p>(43) International Publication Date: 13 March 1997 (13.03.97)</p>
<p>(21) International Application Number: PCT/US96/14962</p> <p>(22) International Filing Date: 30 August 1996 (30.08.96)</p> <p>(30) Priority Data: 08/522,507 1 September 1995 (01.09.95) US</p> <p>(71) Applicant: IMO INDUSTRIES, INC. [US/US]; Hynautic Operations, Morse Controls Division, 1579 Barber Road, Sarasota, FL 34240 (US).</p> <p>(72) Inventor: WAGNER, Jerald, G.; 503 Albee Farm Road #B6, Venice, FL 34292 (US).</p> <p>(74) Agent: SHUPE, Larry, L.; Jansson & Shupe, Ltd., Suite M, 245 Main Street, Racine, WI 53403 (US).</p>	<p>(81) Designated States: CA, CN, JP, KR, European patent (AT, BE, CH, DE, DK, ES, FI, FR, GB, GR, IE, IT, LU, MC, NL, PT, SE).</p> <p>Published <i>With international search report.</i></p>	

(54) Title: IMPROVED MOUNTING ARRANGEMENT FOR ENGINE STEERING CYLINDER**(57) Abstract**

The new "universal" mounting bracket (10) is used to couple a hydraulic steering cylinder (11) to one of first and second brands of outboard engines (12). Such bracket (10) has first and second groups (25, 29) of holes (27, 31, respectively), the holes (27 or 31) comprising each group (25 or 29) positionally corresponding to a bracket attachment hole (43, 45) in the first or second brand of engine (12). The cylinder (11) has first and second spaced mounting faces (61, 63) that are angled with respect to a cylinder axis (75). The bracket (10) has first and second end members (59) contacting the first and second faces (61, 63), respectively. A mounting face (61 or 63) and its respective end member (59) are in compression when resisting steering force. The bracket (10) optionally includes at least one cutout area (49) (and preferably two or more cutout areas (49)) for fitting the bracket (10) around a Zerk fitting (51) on a particular brand or brands of engine (12).

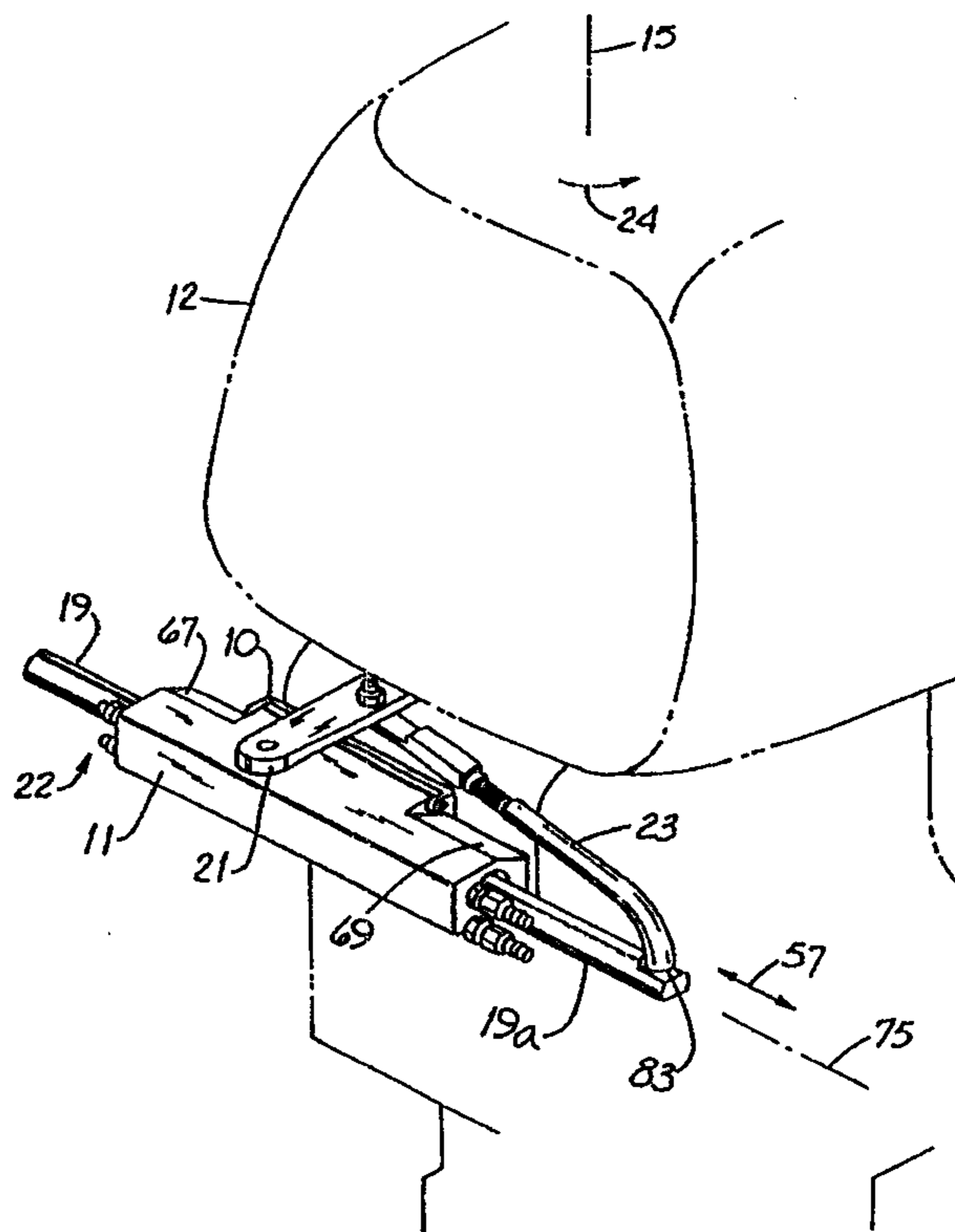

5

10

15 Title: IMPROVED MOUNTING ARRANGEMENT FOR ENGINE STEERING
CYLINDER

Field of the Invention

20 This invention relates generally to ships and boats,
and, more particularly, to vessel steering.

Background of the Invention

25 Water-going vessels are steered in any of a variety
of ways. One way -- commonly used on seagoing vessels
and on larger pleasure craft -- is by a separate rudder
steering a vessel powered by one, two or more "screws"
(propellers). The orientation(s) of the propeller(s)
remain unchanged with respect to the vessel hull.

30 Another way commonly used with smaller pleasure
craft is to pivot all or a part of the propulsion system
so that the rotational axis of the propeller moves with
respect to the vessel hull and its long axis. On so-
called inboard-outboard drives, only a portion of the
propeller drive train pivots. However, on boats driven
35 by outboard engines, the entire engine (but for its stern
mounting bracket and the like) are pivoted on the transom
of the boat.

Smaller outboard engines are steered by an operator sitting at the rearmost seat and grasping the engine handle. Such handle not only pivots the engine about a generally vertical axis, it usually includes a twist-type throttle control. Thus, the operator controls vessel speed and direction with one hand.

But for larger outboard engines, hand steering in that manner is impractical. For one thing, the engine is simply too heavy to steer with one hand. And boats large enough to accept such an engine usually have steering and throttle controls at a forward seat location. The operator faces directly forward as when driving an automobile.

Larger outboard engines are often steered using some type of "force-multiplying" mechanism such as a steering wheel and control cable, the latter as made by Morse Controls and others. Or steering may be by hydraulic cylinder systems as made by Hynautic, Sarasota, Florida. In a common arrangement, the cylinder body is mounted in a fixed location and a cylinder rod is coupled to the engine tiller bar by a steering link. In another arrangement, the rods are at a fixed location and the cylinder body is coupled to the tiller bar for bar movement.

Apparatus for boat steering are shown in U.S. Patent Nos. 2,787,235 (Schroeder); 4,773,882 (Rump); 4,836,812 (Griffiths); 5,340,341 (Yoshimura) and, no doubt, others. A problem faced by outboard engine builders and designers of cylinder-equipped hydraulic steering systems is the matter of mounting the cylinder with respect to the engine. The problem is very evident from an analysis of the noted patents.

In the arrangement disclosed in the Griffiths patent, the center bracket on which the steering cylinder is rigidly mounted is, itself, rigidly attached to the steering arm of the primary engine. The arrangement assumes that such steering arm includes mounting holes

or, dismayingly, the boat builder or user must provide such holes.

The steering assembly shown in the Rump patent uses a cylinder with a projecting tongue that pivotably pins
5 to the engine tiller arm. Like that of the Griffiths patent, the Rump arrangement seemingly assumes that the tiller arm comes equipped with a mounting hole.

The arrangements shown in U.S. Patent No. 2,855,755 (Auger) and in the Schroeder and Yoshimura patents
10 "sidestep" the matter of closely-coupling the cylinder and the engine to one another. Instead, the cylinder is mounted some distance from the engine and long linkages are used to connect the two together. In that way, the cylinder designer can ignore the differing mounting
15 provisions configured by the engine manufacturers.

But these arrangements tend to be (in the vernacular) "Rube-Goldberg-like." Manufacturing boat and engine builders are not likely to be enthusiastic about them, at least because they are aesthetically lacking.
20 And some arrangements are seemingly very time-consuming to mount. (Of course, extended assembly time translates into extended manufactured cost, selling price and, later, difficulty in repair.)

Known prior art mounting arrangements which space
25 the steering cylinder well away from the engine being steered simplify the task of the designer of such mounting arrangements in another way. One need not fit a mounting bracket to avoid such seemingly-innocuous but critical appurtenances as "Zerk" grease fittings for
30 lubricating the tilt tube. (Zerk grease fittings are well known, are installed on, inter alia, passenger autos and are configured for use with a pressurized grease gun.)

Another disadvantage of prior art arrangements like those of the Schroeder, Auger and Griffiths patents
35 involves the bolting arrangement. The forces imposed on the bolts are shear forces and it is only (or substantially only) shear forces that secure the mounting

-4-

5 bracket and the cylinder with respect to one another. To
put it in other words, these prior art arrangements do
not appreciate how to configure a mounting bracket to
substantially avoid imposing shear forces upon the
securing bolts.

10 Yet another disadvantage of prior art arrangements
is that they are not invertible in use. In other words,
they can be used in but a single orientation. Such
arrangements fail to appreciate how a mounting bracket
can be configured to be invertible so as to adapt to a
variety of brands of engines.

15 The fact that prior workers in the field have
sidestepped the problem of trying to directly mount a
hydraulic steering cylinder to any of a variety of
outboard engines is not surprising -- the problem has
persisted for some years and is not easy to solve.
"Single-use" mounting brackets make the work of the boat
builder (or of the company mounting an engine to a boat)
more difficult. This is so because such builder or
20 company must stock a variety of mounting brackets, at
least one for each brand of outboard engine anticipated
to be equipped with a steering cylinder.

25 The invention offers a bold and imaginative solution
to the matter of cylinder/engine mounting. Details
regarding such invention are set forth below.

Objects of the Invention

30 It is an object of the invention to provide a
steering cylinder mounting arrangement overcoming some of
the problems and shortcomings of the prior art.

Another object of the invention is to provide a
steering cylinder mounting arrangement which is
aesthetically attractive.

35 Another object of the invention is to provide a
steering cylinder mounting arrangement which is compact
and space-saving.

Yet another object of the invention is to provide a steering cylinder mounting arrangement that accommodates different outboard engines.

Another object of the invention is to provide a steering cylinder mounting arrangement that substantially avoids imposing shear forces upon the mounting bolts.

Still another object of the invention is to provide a steering cylinder mounting arrangement which reduces mounting-hardware-related inventory.

Another object of the invention is to provide a steering cylinder mounting arrangement which accommodates outboard engine Zerk grease fittings.

10

Another object of the invention is to provide a steering cylinder mounting arrangement in which the mounting bracket is invertible to facilitate adapting the arrangement to a variety of outboard engines. How these and other objects are accomplished will become apparent from the following descriptions and from the drawings.

Summary of the Invention

According to the present invention, there is provided the combination of a boat having a boat transom and a mounting bracket coupling a hydraulic steering cylinder to a first brand of outboard engine mounted on the transom, characterized in that:

20

– the steering cylinder is coupled to the first brand of engine using a first group of holes, each of which positionally corresponds to a bracket attachment hole in the first brand of engine; and

– the bracket includes a second group of holes, each of which positionally corresponds to a bracket attachment hole in the second brand of engine;

and wherein:

30

- the second group of holes excludes the first group of holes;
- the bracket is affixed to the first brand of engine;
- the bracket and the cylinder are above the transom;
- the bracket includes first and second edges;

- the first edge is upward when the bracket is positioned for attachment to the first brand of engine; and

- the second edge is upward when the bracket is positioned for attachment to the second brand of engine.

According to the present invention there is also provided the combination of a boat transom for a boat and a mounting bracket coupling a hydraulic steering cylinder to a first brand of outboard engine mounted on the transom, characterized in that:

- the steering cylinder is coupled to the first brand of engine using a first group of holes, each of which positionally corresponds to a bracket attachment hole in the first brand of engine; and

- the bracket includes a second group of holes, each of which positionally corresponds to a bracket attachment hole in a second brand of engine;

and wherein:

- the second group of holes excludes the first group of holes;

- the bracket is affixed to the first brand of engine;

- the bracket and the cylinder are above the transom;

- the bracket includes first and second edges;

- the first edge is upward when the bracket is positioned for attachment to the first brand of engine; and

- the second edge is upward when the bracket is positioned for attachment to the second brand of engine.

Preferably, the invention involves a mounting bracket for coupling a hydraulic steering cylinder to either one of first and second "brands" (e.g., Outboard Marine Corporation (OMC), Mercury, Suzuki) of outboard engines. The bracket has first and second groups of holes, each hole of each group positionally corresponding to a bracket attachment hole in a particular brand of engine. (Stated another way, each group of bracket holes has plural holes corresponding in location and number to the cylinder mounting holes of a particular brand of engine).

6a

In a highly-preferred embodiment, the bracket also has a third group of holes, each of which positionally corresponds to a bracket attachment hole in a third brand of engine. Each group of holes may includes two, three, four or even more holes. However, in preferred embodiments, there are four holes in each group.

Preferably, the new bracket also has features permitting such bracket to be used in either of two orientations, each inverted from the other. Such bracket is thereby adapted to fit a wider variety of engine brands and/or to accommodate certain engine features. The bracket has first and second edges, the first edge
10 being upward when the bracket is positioned for attachment to the first brand of engine. When the bracket is positioned for attachment to the second brand of engine, the second edge is upward. In a specific embodiment, both edges are parallel and generally horizontal in either orientation.

A preferred mounting location for the new bracket is closely adjacent to the tilt tube of an outboard engine, i.e., that elongate, generally-cylindrical tube about which the engine pivots or tilts. It is desirable to periodically lubricate the tube for easy tilting and manufacturers install one or more grease fittings for that purpose.

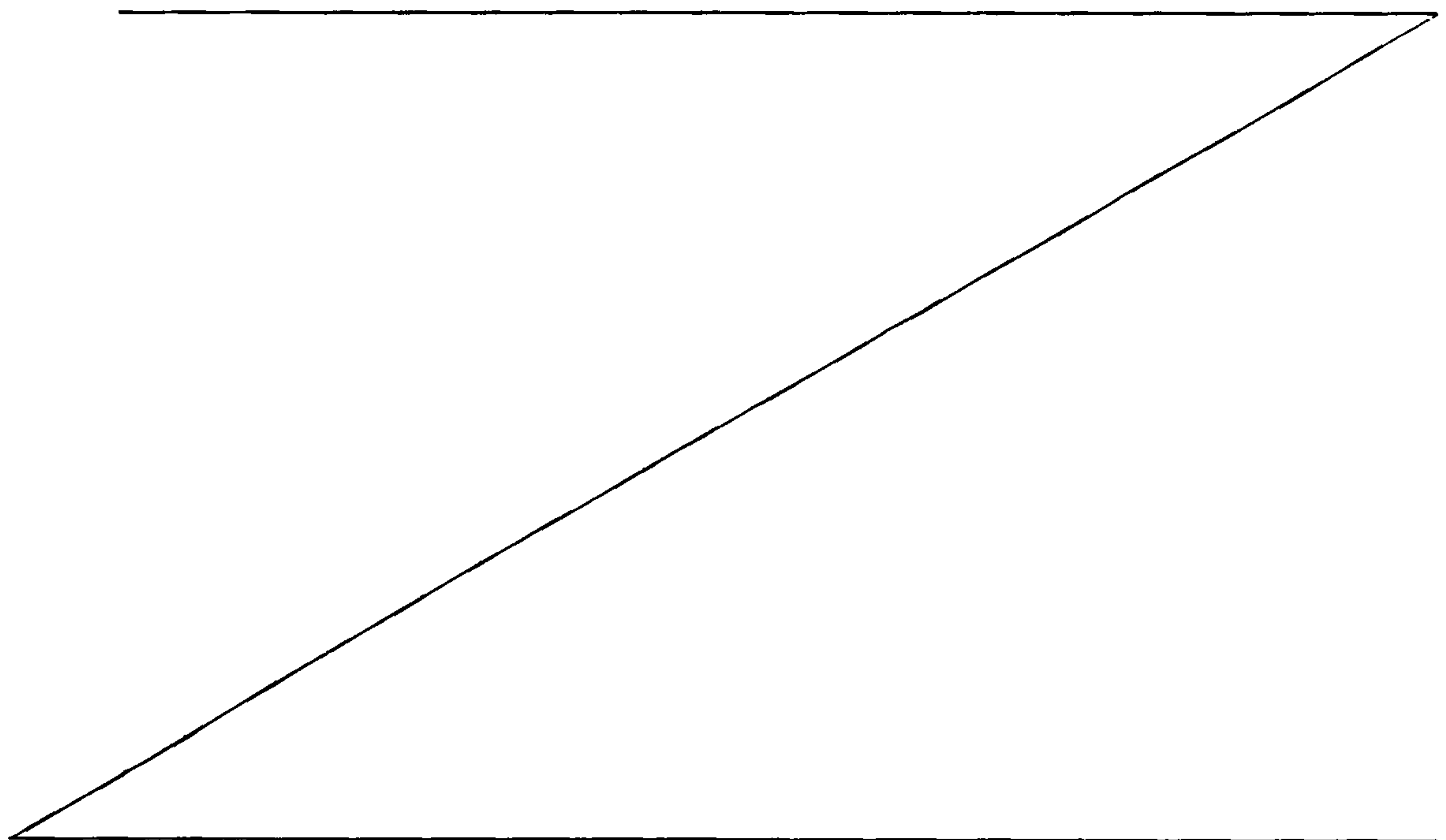

Preferably, another feature of the new bracket involves at least one bracket cutout area along one edge, e.g., the second edge so that the bracket can be fitted around a Zerk fitting on a particular engine brand. In a highly-preferred embodiment, the bracket has two or three cutout areas along such second edge for adapting the bracket to at least two brands of engines.

Preferably, the new bracket is used in combination with a steering cylinder mounted to the engine by such bracket. The cylinder extends along an axis and has a steering rod exerting a steering force that pivots the engine for steering.

10 Preferably, the cylinder has first and second spaced mounting faces which are angled with respect to the axis (preferably at 90° to the axis) and the bracket includes conformably-spaced first and second end members contacting the first and second faces, respectively. The first and second mounting faces and, respectively, the first and second end members are alternately in compression when resisting steering force. (That is to say, when steering left, the first end member and first face are in compression and when steering right, the second end member and second face are in compression).

20 Such configuration substantially prevents shear forces from being applied to the cylinder/bracket holding bolts. In other words, such bolts are used substantially only in tension as bolts are intended to be used).

Preferably, and that is not all. There are other aspects of the invention that enhance the rigidity with which the cylinder and the bracket are secured to one another. The steering cylinder includes first and end portions, each having one or plural surfaces. The bracket end members each include an edge contacting the respective surface or plural surfaces. The mounting bracket thereby resists cylinder twisting about an axis coincident with or parallel to the cylinder axis. (For reasons that will become apparent from the detailed description, cylinder end portions with plural flat surfaces are preferred).

30 Preferably, in another aspect of the invention, a steering linkage extends between the engine tiller and aperture at the end of the rod. Such linkage includes first and second link members, e.g., a clevis and a draglink, threaded to

one another. The first link member has plural pin openings while the second link member has but a single pin opening, all openings being generally normal to the long axis of the linkage.

Preferably, a pin extends laterally between the pin opening in the second link member and one of the pin openings in the first link member. Such threaded attachment permits adjusting the aggregate length of the linkage by adjusting the position of the first link member on the second link member. And the pin prevents such adjusted position from changing by preventing rotation of the first link member with respect to the second link member.

10 Preferably, the first link member includes a flat, tongue-like attachment portion for coupling the first link member to the tiller. Such attachment portion is held in alignment with the tiller by the pin.

According to the present invention, there is also provided the combination of (a) a steering cylinder having a housing extending along a longitudinal axis and a rod for exerting steering force, and (b) a mounting bracket for attaching the cylinder to an outboard engine having plural cylinder mounting holes arranged in a mounting hole pattern, characterized in that:

- the bracket has plural holes corresponding in location and number to the cylinder mounting holes of the engine;
- 20 – the cylinder includes first and second spaced mounting faces angled with respect to the axis; and
- the bracket includes first and second angled end members coextensive with the first and second angled faces, respectively; and
- the first mounting face and the first end member are in compression when resisting steering force.

Other details of the invention are set forth in the following detailed description and in the drawings.

Brief Description of the Drawings

30 **FIGURE 1 is a representative view of a boat equipped with an outboard engine and a steering cylinder secured to the engine by the new mounting bracket.**

8a

FIGURE 2 is a close-up perspective view of the improved outboard engine steering cylinder shown in conjunction with an outboard engine represented in dashed outline.

FIGURE 3 is an elevation view of the new mounting bracket arranged for attachment to a pre-1989 Mercury engine.

FIGURE 4 is an elevation view of the new mounting bracket arranged for attachment to an OMC engine.

FIGURE 5 is an elevation view of the new mounting bracket arranged for attachment to a Suzuki "V" engine.

10

FIGURE 6 is an elevation view of the new mounting bracket arranged for attachment to a Yamaha engine.

FIGURE 7 is an elevation view of the new mounting bracket arranged for attachment to a Mercury engine.

FIGURE 8 is an elevation view of the new mounting bracket arranged for attachment to an OMC commercial engine and certain other OMC engines.

FIGURE 9 is an elevation view of the new mounting bracket arranged for attachment to a Suzuki In-Line 4 engine.

FIGURE 10 is an exploded perspective view of a cylinder housing and the mounting bracket.

20

FIGURE 11 is a view taken generally along the cylinder axis of FIGURE 2 and showing the relative position of the cylinder to the engine stern bracket when

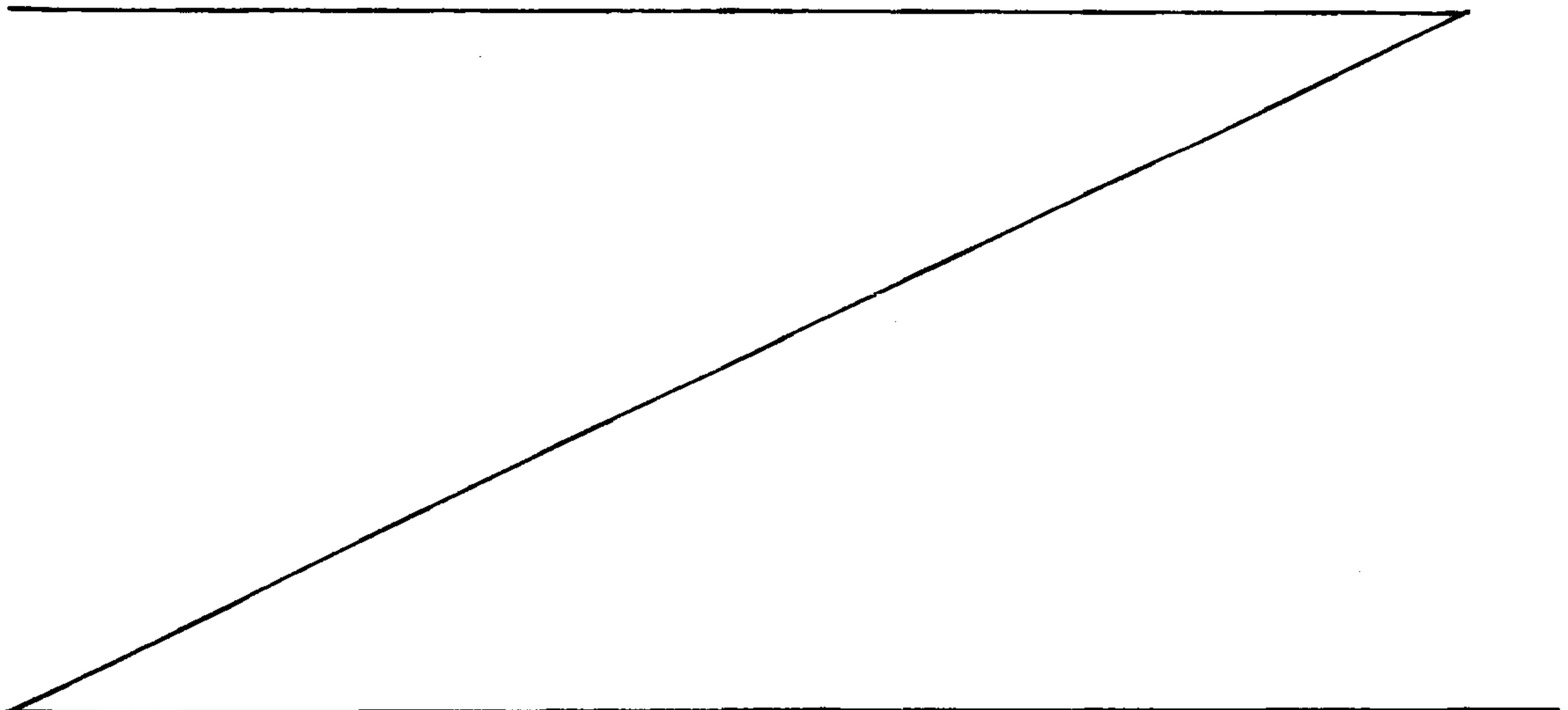

the engine is in its normal vessel-propelling position. Parts are broken away.

FIGURE 12 is a view taken generally along the cylinder axis of FIGURE 2 and showing the relative position of the cylinder to the engine stern bracket when the engine is tilted toward horizontal. Parts are broken away.

FIGURE 13 is a side elevation view of steering linkage. Surfaces of parts are shown in dashed outline.

10

Detailed Descriptions of Preferred Embodiments

Before describing details of the new bracket 10 and how it is used to mount a cylinder 11, it will be helpful to have a general understanding of how the cylinder 11 is mounted on and used to steer an outboard engine.

15

Referring first to FIGURE 1, an outboard engine 12 is mounted to the stern transom of a boat 13. The steering cylinder 11 is mounted to the engine 12 in any of the several ways described below. When the cylinder 11 is actuated, the engine 12 pivots about a generally-vertical steering axis 15 which is about normal to the boat long axis 17.

20

Referring also to FIGURE 2, the steering cylinder 11 is of the "double-ended" type, so named because a rod 19, 19a extends from respective cylinder ends. The rod 19a is coupled to the engine tiller bar 21 by a linkage 23 and is capable of being extended or retracted by the introduction of hydraulic fluid into one of the two fittings 22. When the rod 19a is extended, the engine 12 pivots counterclockwise (as viewed "top down" and as symbolized by the arrow 24) and the boat 13 steers to the right.

25

30

Referring next to FIGURES 3 through 7, the new bracket 10 has plural groups of holes, e.g., the group 25 comprising holes 27 (FIGURE 7), the group 29 comprising holes 31 (FIGURE 4) and the group 33 comprising holes 35 (FIGURE 5). The holes of each group 25, 29, or 33 are

35

-10-

sized and located to correspond with the size and location of bracket mounting holes on outboard engines manufactured by each of several different companies. The groups 25, 29 and 33 fit outboard engines made by Mercury (pre-1989), OMC and Yamaha, respectively. (It is to be noted that the orientation of the bracket 10 in FIGURES 3 and 6 and the orientation shown in FIGURES 4 and 5 are rotated 180° from one another.) This configuration imparts a degree of "universality" to the bracket in that such configuration enables a single bracket (and steering cylinder) to be used in conjunction with any of a variety of engines.

FIGURE 5 shows the group 33 used to attach the bracket 10 to the Suzuki "V" engine and FIGURE 7 shows the group 25 used to attach the bracket 10 to other Mercury engines. The bracket 10 has first and second edges 37 and 39, respectively, and it will be noted that in FIGURES 4, 5 and 7, for example, the bracket 10 is oriented with the first edge 37 upward. In exemplary FIGURES 3 and 6, the bracket 10 is oriented with the first edge 37 downward. In the specific illustrated embodiment, both edges 37, 39, are generally linear, generally parallel to one another and generally horizontal when the bracket 10 is mounted.

FIGURES 8 and 9 illustrate special situations involving attaching the bracket 10 to relatively-rare engines, i.e., OMC Commercial/SPL and Suzuki In-Line 4, respectively. In both situations, the bracket 10 attaches to an adapter plate 41 using the holes 43 or 45 for identification. The adapter plate 41 attaches to the engine 12 using flush, tapered, flat-head bolts 47 extending through the holes 43 or 45 marked X. Group 29 and its holes 31 are used to mount the bracket 10 to the adapter plate 41.

Referring to exemplary FIGURES 4 and 7, another feature of the new bracket 10 involves at least one bracket cutout area 49 along the second edge 39 so that

-11- .

the bracket 10 can be fitted around a Zerk fitting 51 on a particular brand of engine. In a highly-preferred embodiment, the bracket 10 has two or three cutout areas 49 along such edge 39 for adapting the bracket 10 to at least two different brands of engines. For example, FIGURES 3 and 7 show how the center cutout area 49 adapts the bracket 10 to Mercury engines of different model years and FIGURE 4 shows how the end cutout areas 49 adapt the bracket 10 to an OMC engine.

FIGURES 2, 10, 11 and 12 show other details of the mounting bracket 10 used to mount the cylinder 11 to the engine 12. The forces imposed on the bracket 10 by the cylinder 11 (such forces being represented by the double-ended arrow 57) are generally left/right as viewed in FIGURES 2 and 10.

A highly preferred bracket 10 has end members 59 attached to the cylinder at the mounting faces 61, 63, respectively. The members 59 and the faces 61, 63 are generally normal to the direction 57 of imposed forces and are cooperatively spaced so that when the cylinder 11 and bracket 10 are brought together, there is slight sliding clearance between the members 59 and their respective faces 61, 63. When so configured, the forces of steering are imposed across the relatively-wide areas of the members 59 and faces 61, 63. There are no (or substantially no) shear forces imposed upon the bolts 65 used to secure the bracket 10 to the cylinder 11 to one another.

Referring next to FIGURES 2, 10, 11 and 12, the steering cylinder 11 includes first and second end portions 67, 69, respectively, each having plural surfaces 71. In the specific embodiment of FIGURE 10, the surfaces 71 are generally flat.

The bracket end members 59 each include an edge 73 contacting the respective plural surfaces 71 as shown in FIGURE 10. The mounting bracket 10 thereby resists cylinder twisting about an axis coincident with or

-12- .

parallel to the cylinder axis 75. And any aft-of-vessel steering force components are imposed across the mating surfaces 71 and edge 73, eliminating or substantially eliminating shear forces on the bolts 65.

5 After understanding this specification and the drawings, persons working in the art will appreciate how to make cylinder end portions 67, 69 with a surface or surfaces 71 of differing shapes. Such shapes, e.g., cylindrical, elliptical or flat across the cylinder 11, are contemplated by the invention. FIGURES 11 and 12 show how the engine 12 can be pivoted about the tilt tube axis 77 and the cylinder end portions 67, 69, the bolts 65 and the bracket members 59 will nevertheless "clear" the engine stern bracket 79 and projections 81 thereof.

10 Referring next to FIGURES 2, 11, 12 and 13, the steering linkage 23 extends between the engine tiller bar 21 and aperture 83 at the end of the rod 19a. Such linkage 23 "transfers" steering force from the rod 19a to the engine tiller bar 21 for engine pivoting and steering.

15 The linkage 23 includes first and second link members 85, 87, respectively, which are preferably embodied as a clevis 85a and a draglink 87a, respectively. Such members 85, 87 are threaded to one another using fine-pitch threads 89 permitting good "vernier" adjustment of linkage length.

20 The first link member 85 has plural pin openings 91 while the second link member 87 has but a single pin opening 93, all openings 91, 93 being generally normal to the long axis 97 of the linkage 23. A pin 99 extends laterally between the pin opening 93 in the second link member 87 and one of the pin openings 91 in the first link member 85. After the proper linkage length and orientation of the link member 85 have been selected, the pin 99 is inserted and prevents such adjusted position from changing.

-13- .

The first link member 85 includes a flat, tongue-like attachment portion 103 for coupling the first link member 85 to the tiller bar 21. The flat surfaces 105 of such attachment portion 103 are held in alignment with the flat surface of the tiller bar 21 by the pin 99.

A comparison of exemplary FIGURES 7 and 8 shows that the link member 85 is invertible and can be rotated so that the attachment portion 103 is upward as in FIGURE 7 or downward as in FIGURE 8. In other words, the attachment portion 103 can be offset to either side of the linkage long axis 97. This feature complements bracket universality by permitting the height of the portion surfaces 105 to be changed slightly to accommodate slightly-different tiller heights, to permit the portion 103 to be adjacent to the upper or lower surface of the tiller bar 21 or to facilitate either standard or high-speed operating modes on any of several different engines.

To couple the attachment portion 103 and the tiller bar 21 to one another, a bushing 107 is inserted into an opening 109 in the portion 103 and a screw 111 inserted through the bushing 107 and threaded to the tiller bar 21. The vertical dimension of the bushing 107 as viewed in any of the FIGURES 3 through 9 is slightly greater than the thickness of the attachment portion 103. In that way, the screw 111 can be securely tightened without preventing the attachment portion 103 from pivoting on the screw 111 as the engine 12 is steered.

FIGURE 13 has indicia (arrows 115) showing the recommended length of the linkage 23 for various brands of engines and for either standard or high-speed operation. The length indicia for Mercury and Yamaha at standard and high-speed settings are shown as examples. It will be noted that for high-speed operation, the recommended length of the linkage 23 is less than for standard operation. The reason is that a shorter linkage

-14- .

23 can thereby be attached to a distal hole 117 in the tiller bar 21.

While the principles of the invention have been shown and described in connection with specific
5 embodiments, it is to be understood clearly that such embodiments are by way of example and are not limiting.

WHAT IS CLAIMED IS:

1. The combination of a boat having a boat transom and a mounting bracket coupling a hydraulic steering cylinder to a first brand of outboard engine mounted on the transom, characterized in that:

– the steering cylinder is coupled to the first brand of engine using a first group of holes, each of which positionally corresponds to a bracket attachment hole in the first brand of engine; and

10 – the bracket includes a second group of holes, each of which positionally corresponds to a bracket attachment hole in the second brand of engine;

and wherein:

– the second group of holes excludes the first group of holes;

– the bracket is affixed to the first brand of engine;

– the bracket and the cylinder are above the transom;

– the bracket includes first and second edges;

– the first edge is upward when the bracket is positioned for attachment to the first brand of engine; and

20 – the second edge is upward when the bracket is positioned for attachment to the second brand of engine.

2. The combination of claim 1, wherein each group of holes includes at least three holes.

3. The combination of claim 2, wherein each group of holes includes four holes.

4. The combination of claim 1, wherein the bracket is configured for coupling the cylinder to a third brand of engine, the bracket further including a third group of holes, each of which positionally corresponds to a bracket attachment hole in the third brand of engine.

5. The combination of claim 1, wherein the steering cylinder extends along an axis and has a steering rod exerting a steering force and wherein:

– the cylinder includes first and second spaced mounting faces angled with respect to the axis; and

– the bracket includes first and second end members contacting the first and second faces, respectively,

whereby the first mounting face and the first end member are in compression when resisting the steering force.

6. The combination of claim 5, wherein the bracket includes at least one cutout area for fitting the bracket around a Zerk fitting on the first brand of engine.

7. The combination of claim 6, wherein the mounting faces are generally normal to the axis.

8. The combination of (a) a steering cylinder having a housing extending along a longitudinal axis and a rod for exerting steering force, and (b) a mounting bracket for attaching the cylinder to an outboard engine having plural cylinder mounting holes arranged in a mounting hole pattern, characterized in that:

– the bracket has plural holes corresponding in location and number to the cylinder mounting holes of the engine;

– the cylinder includes first and second spaced mounting faces angled with respect to the axis; and

– the bracket includes first and second angled end members coextensive with the first and second angled faces, respectively; and

– the first mounting face and the first end member are in compression when resisting steering force.

9. The combination of claim 8, wherein the mounting faces are generally normal to the axis.

10. The combination of claim 8, wherein the bracket includes at least one cutout area for fitting the bracket around a grease fitting on the engine.

11. The combination of a boat transom for a boat and a mounting bracket coupling a hydraulic steering cylinder to a first brand of outboard engine mounted on the transom, characterized in that:

- the steering cylinder is coupled to the first brand of engine using a first group of holes, each of which positionally corresponds to a bracket attachment hole in the first brand of engine; and

- the bracket includes a second group of holes, each of which positionally corresponds to a bracket attachment hole in a second brand of engine;

and wherein:

- the second group of holes excludes the first group of holes;

- the bracket is affixed to the first brand of engine;

- the bracket and the cylinder are above the transom;

- the bracket includes first and second edges;

- the first edge is upward when the bracket is positioned for attachment to the first brand of engine; and

- the second edge is upward when the bracket is positioned for attachment to the second brand of engine.

12. The combination of claim 11, wherein the bracket is configured for coupling the cylinder to a third brand of engine, the bracket further including a third group of holes, each of which positionally corresponds to a bracket attachment hole in the third brand of engine.

13. The combination of claim 11, wherein the steering cylinder extends along an axis and has a steering rod exerting a steering force and wherein:

- the cylinder includes first and second spaced mounting faces angled with respect to the axis; and

– the bracket includes first and second end members contacting the first and second faces, respectively, whereby the first mounting face and the first end member are in compression when resisting the steering force.

14. The combination of claim 13, wherein the bracket includes at least one cutout area for fitting the bracket around a Zerk fitting on the first brand of engine.

15. The combination of claim 14, wherein the mounting faces are generally normal to the axis.

1/7

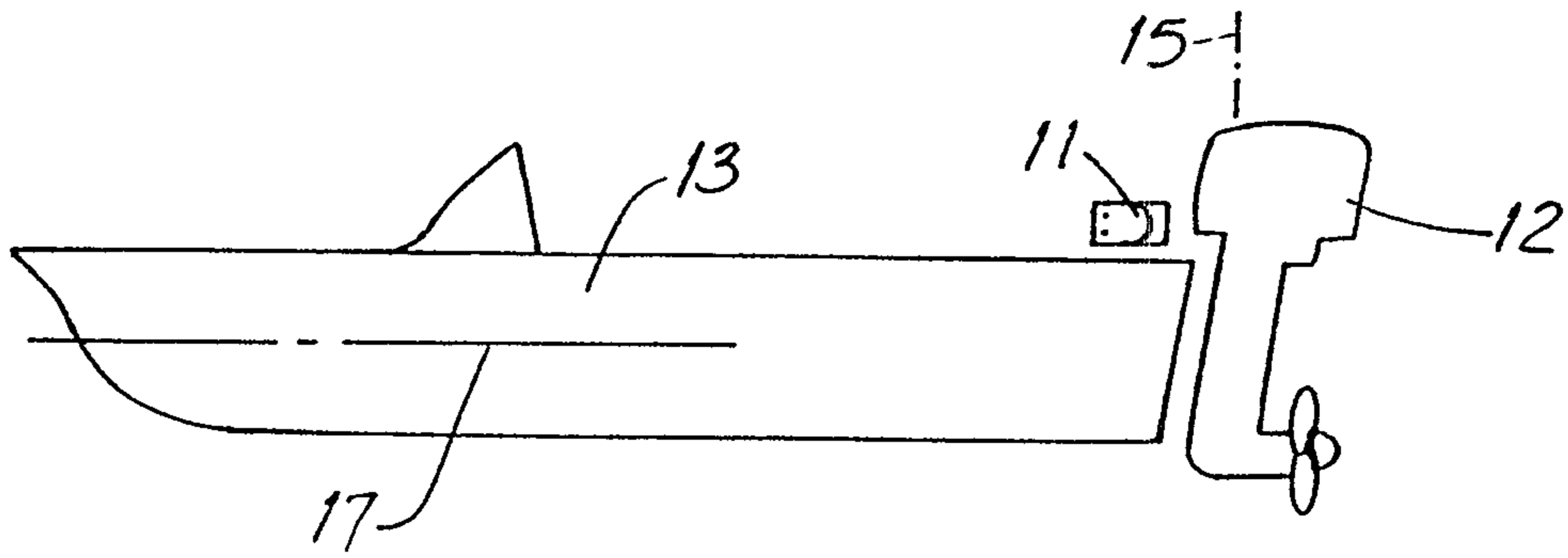

FIG. 1

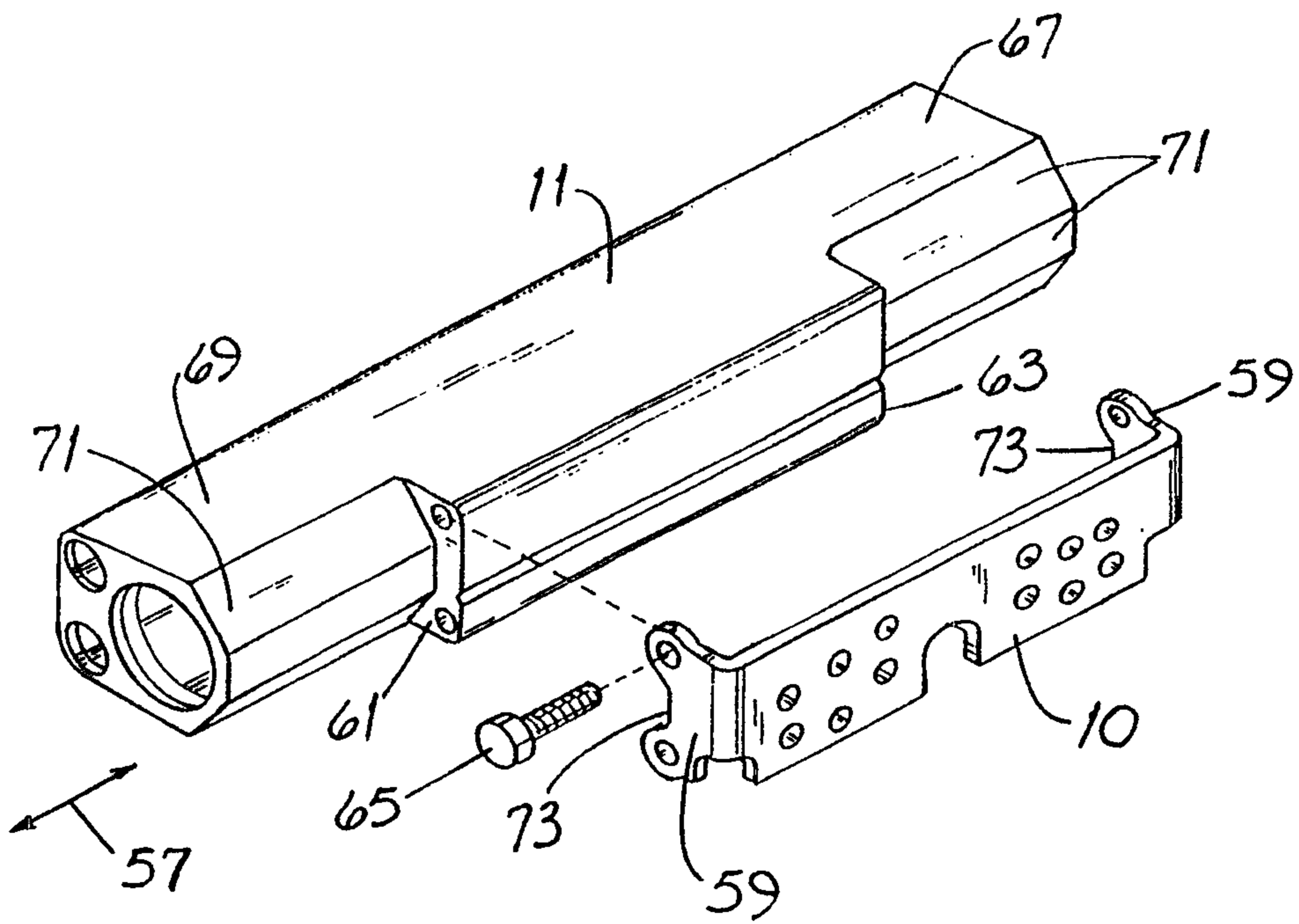

FIG. 10

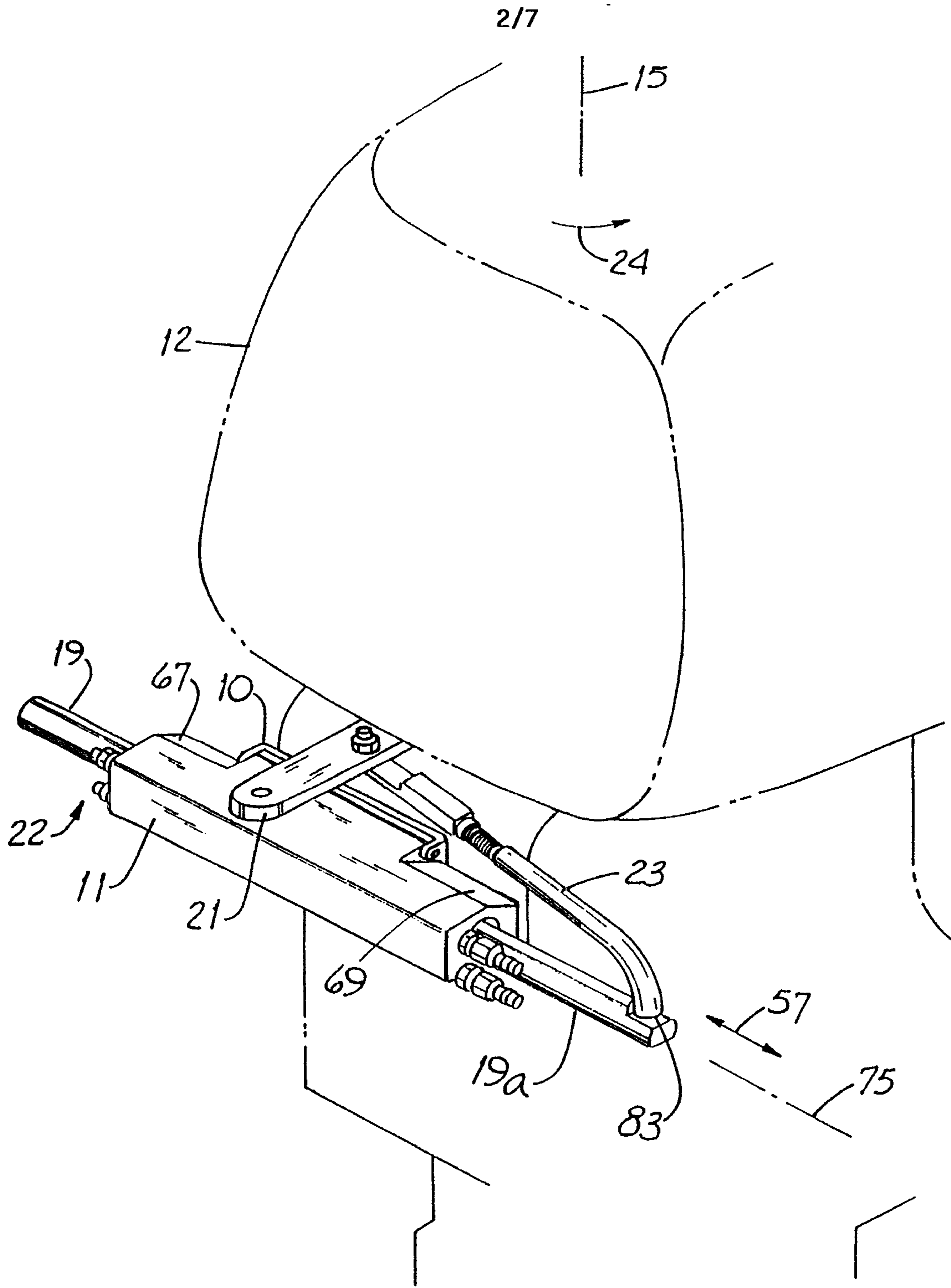
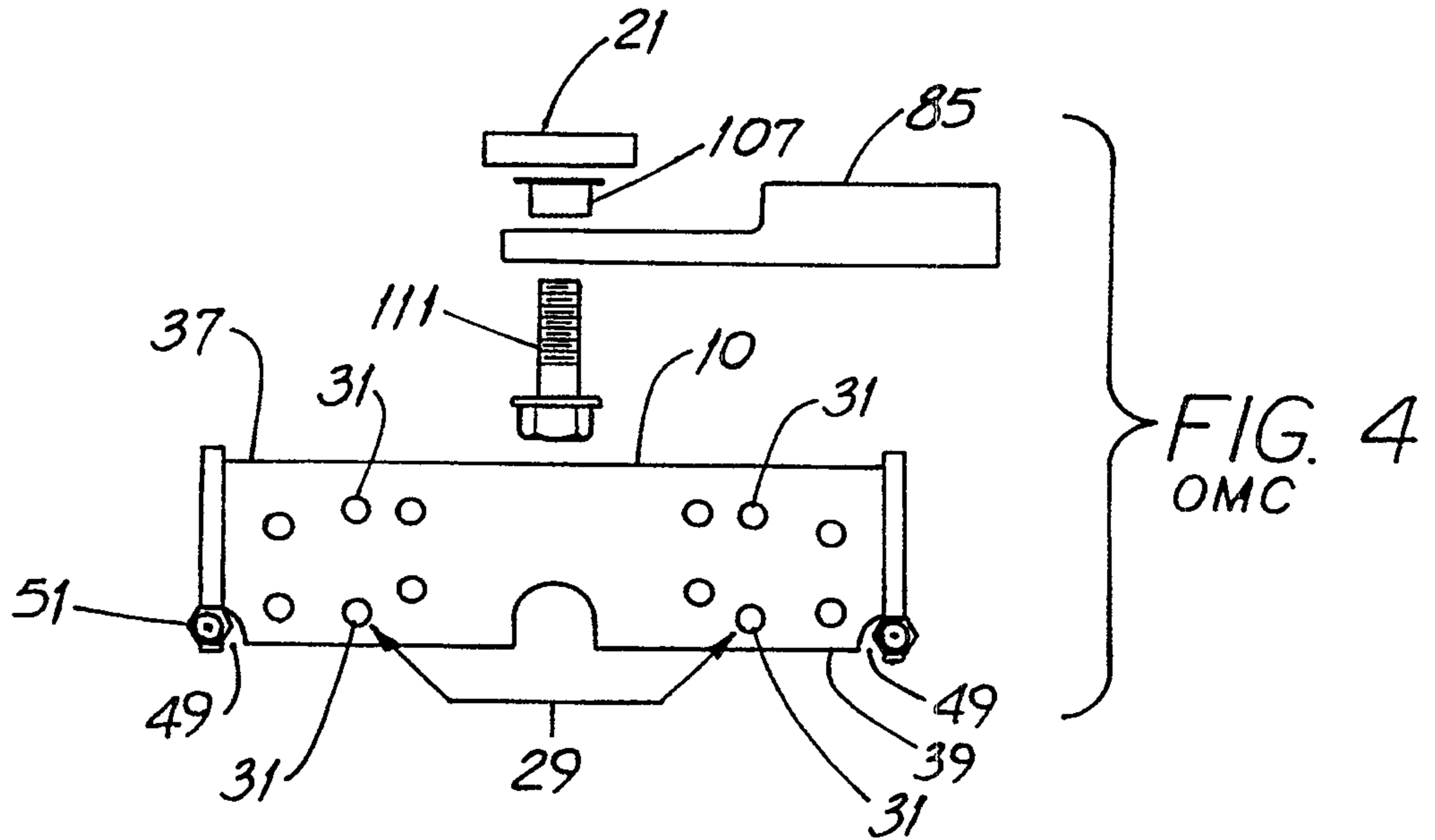
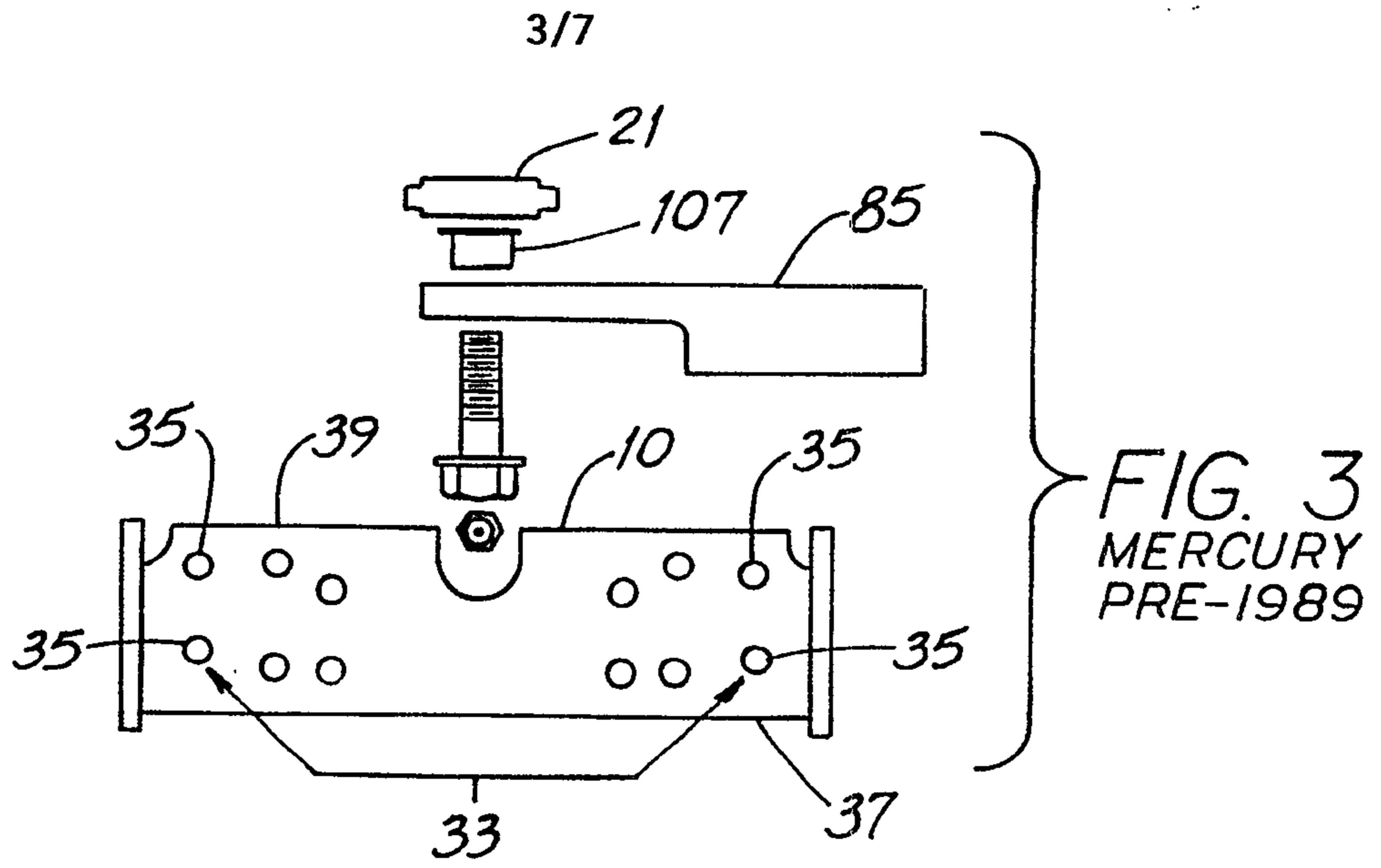
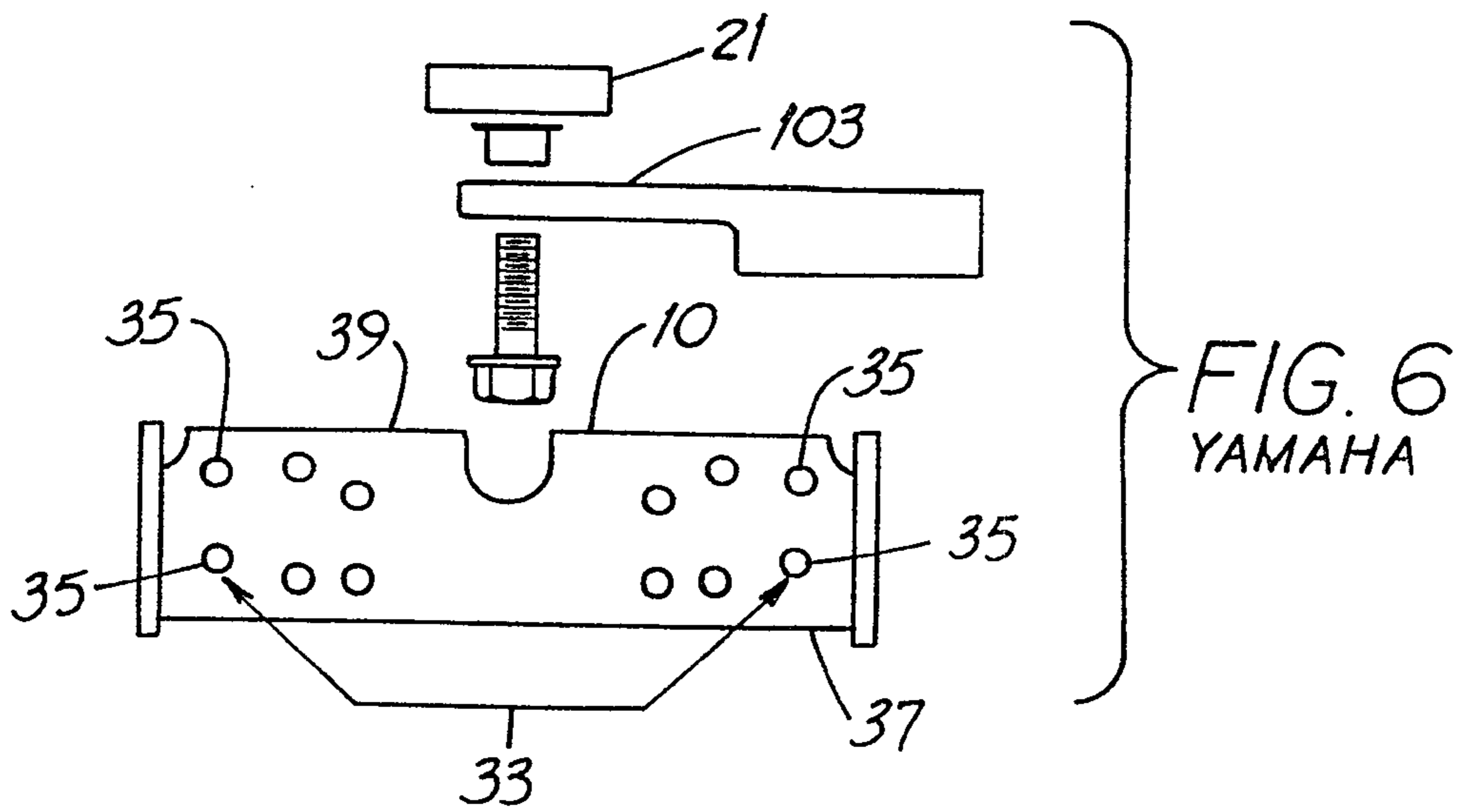
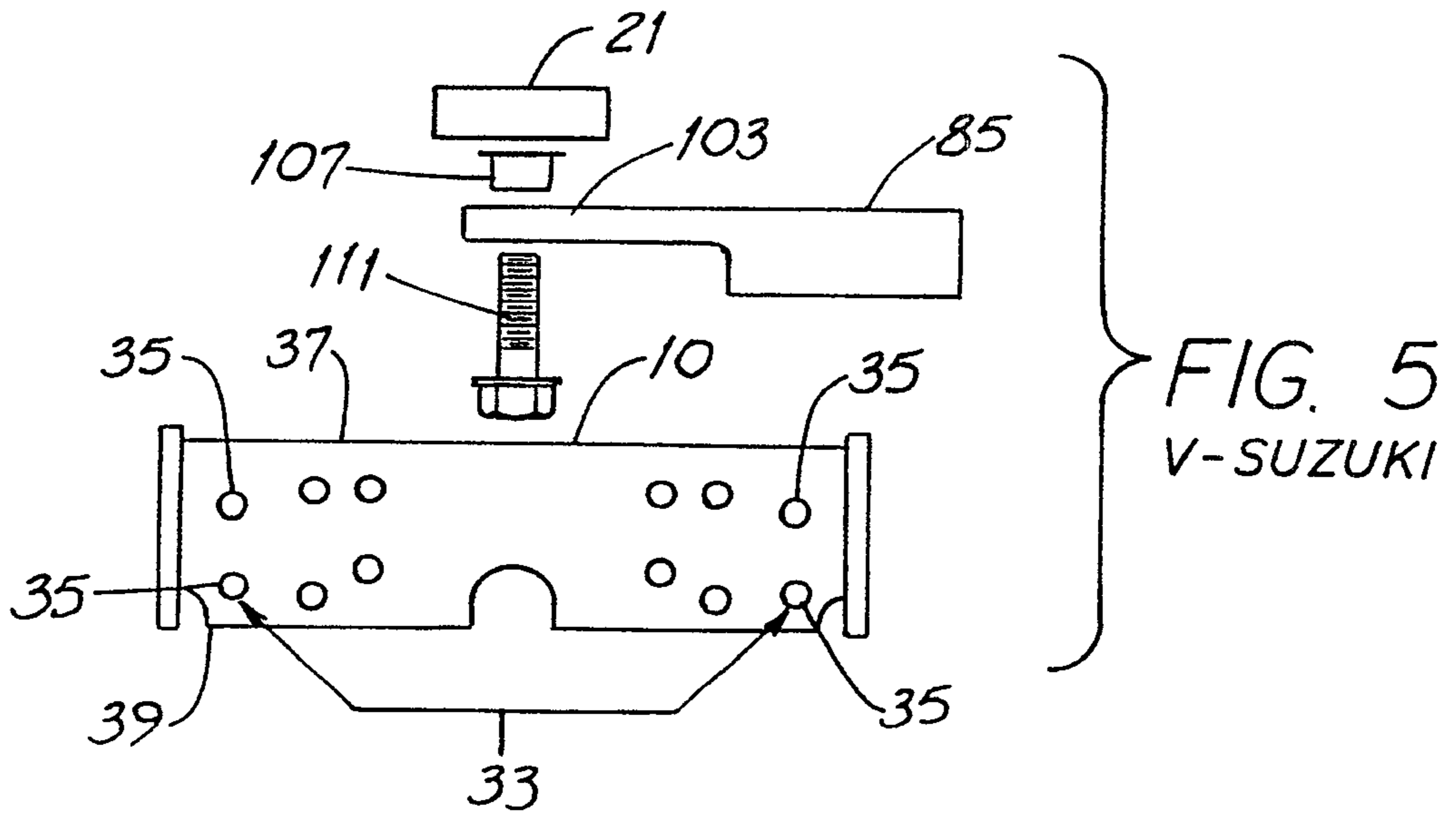

FIG. 2





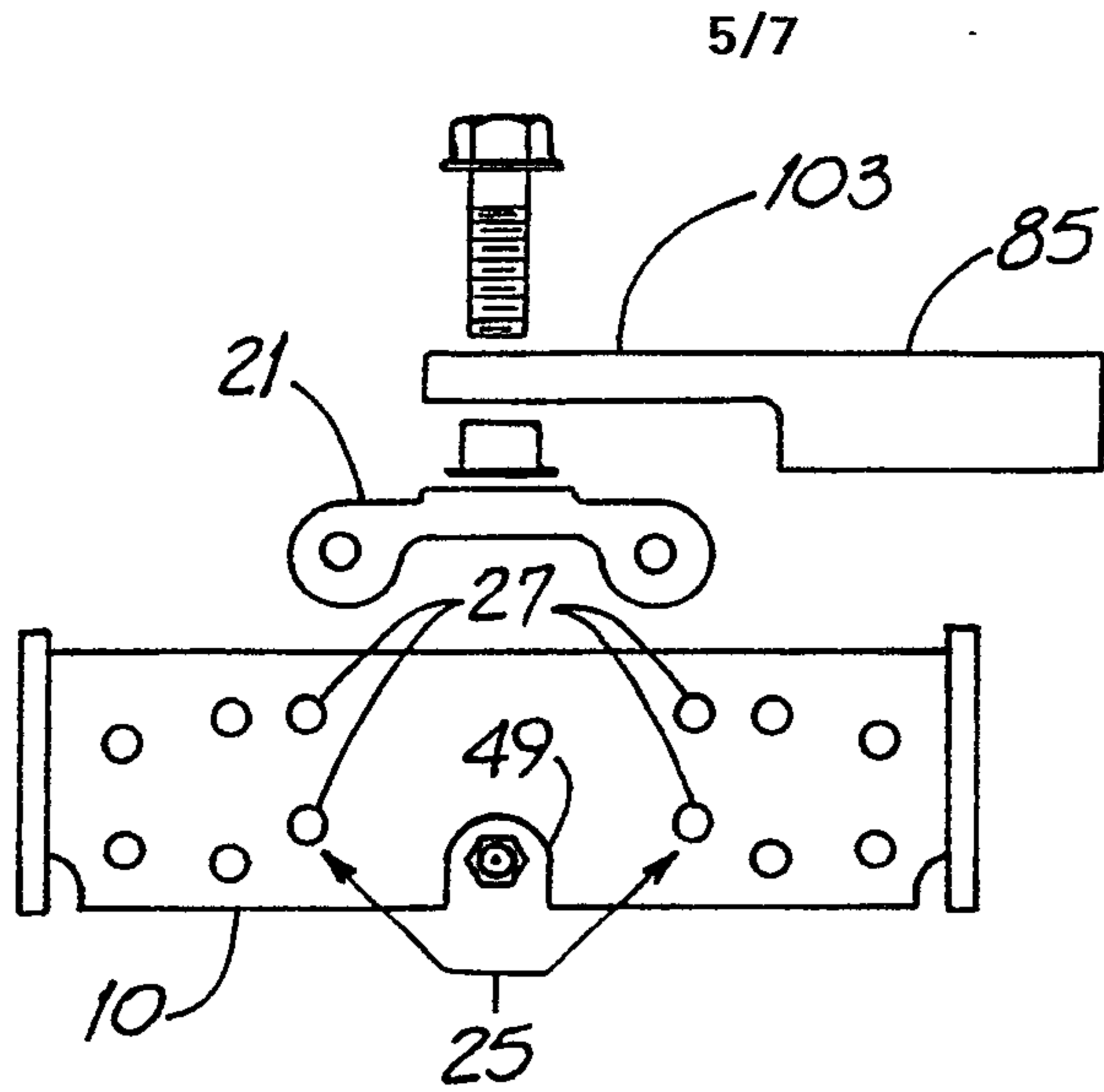

FIG. 7
MERCURY

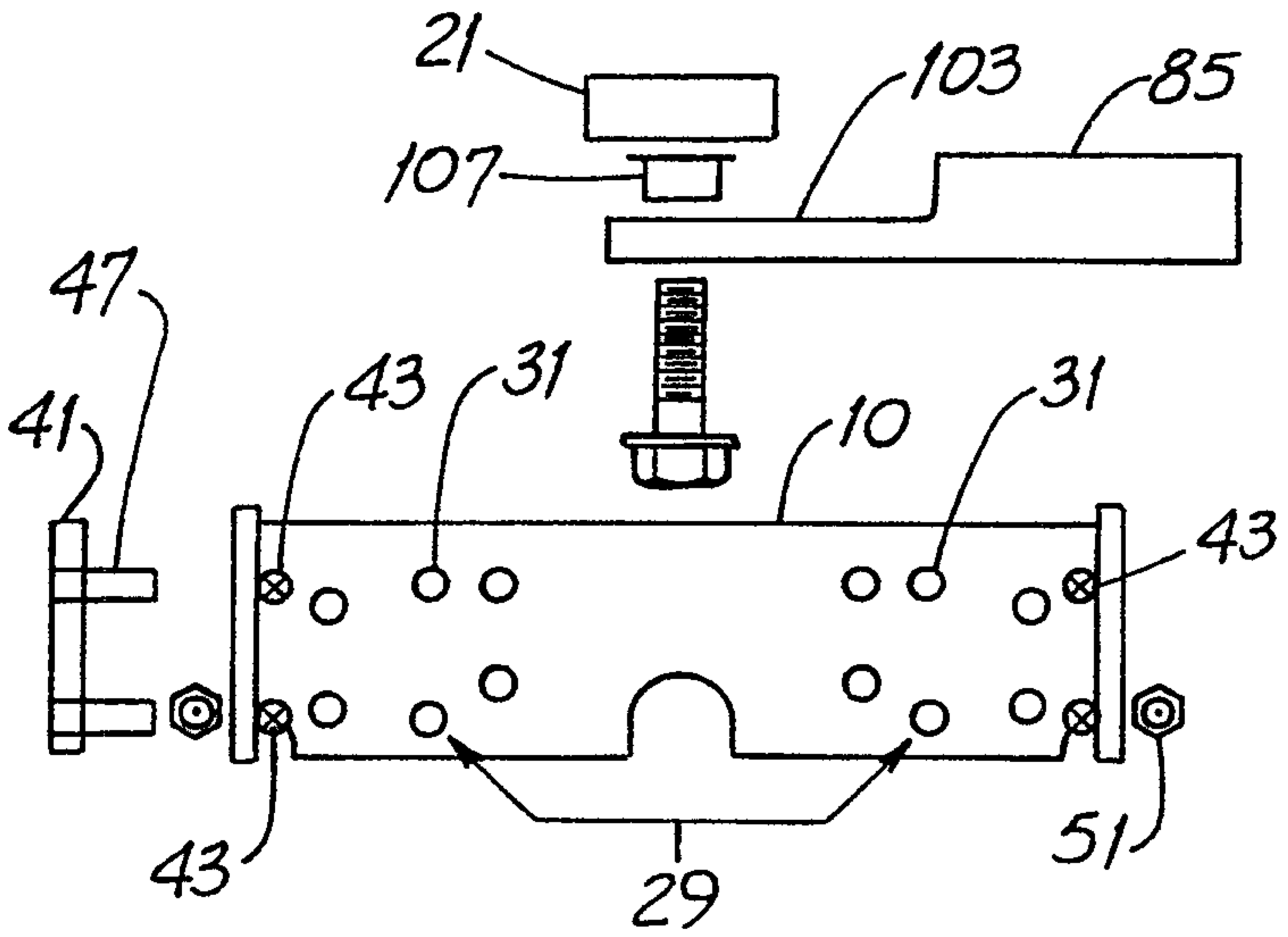

FIG. 8
OMC
COMMERCIAL

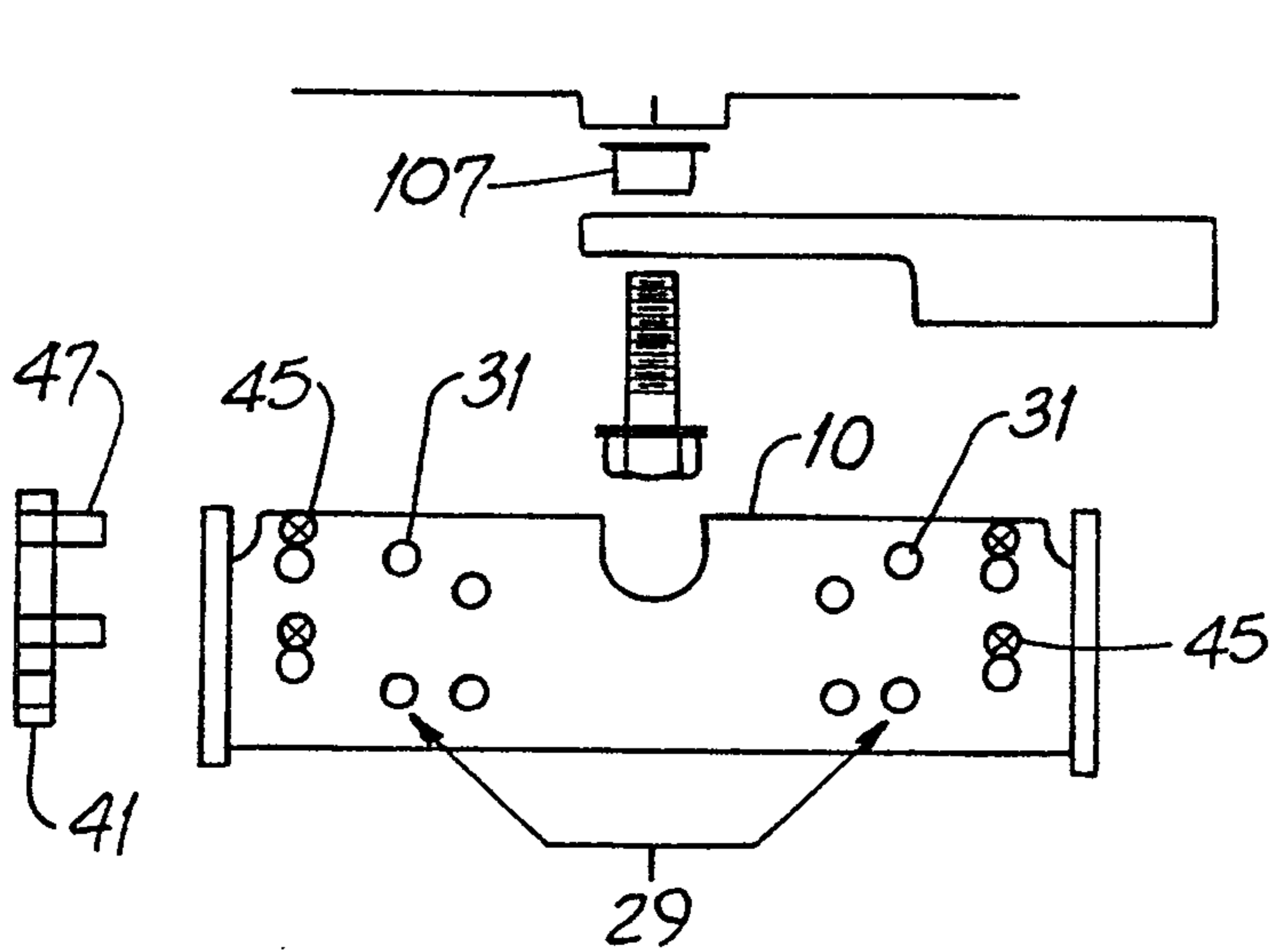

FIG. 9
SUZUKI
1-4

6/7

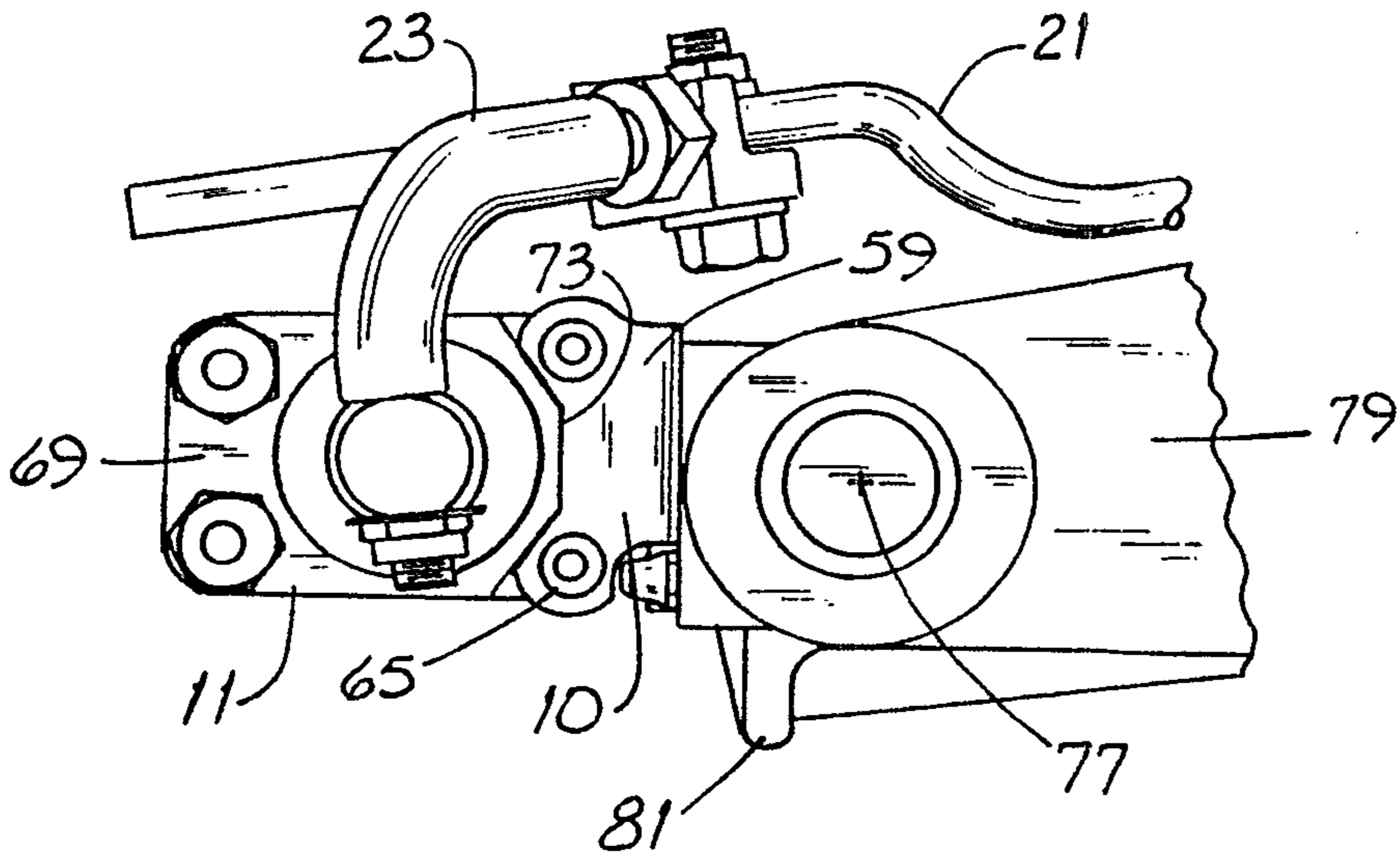

FIG. 11

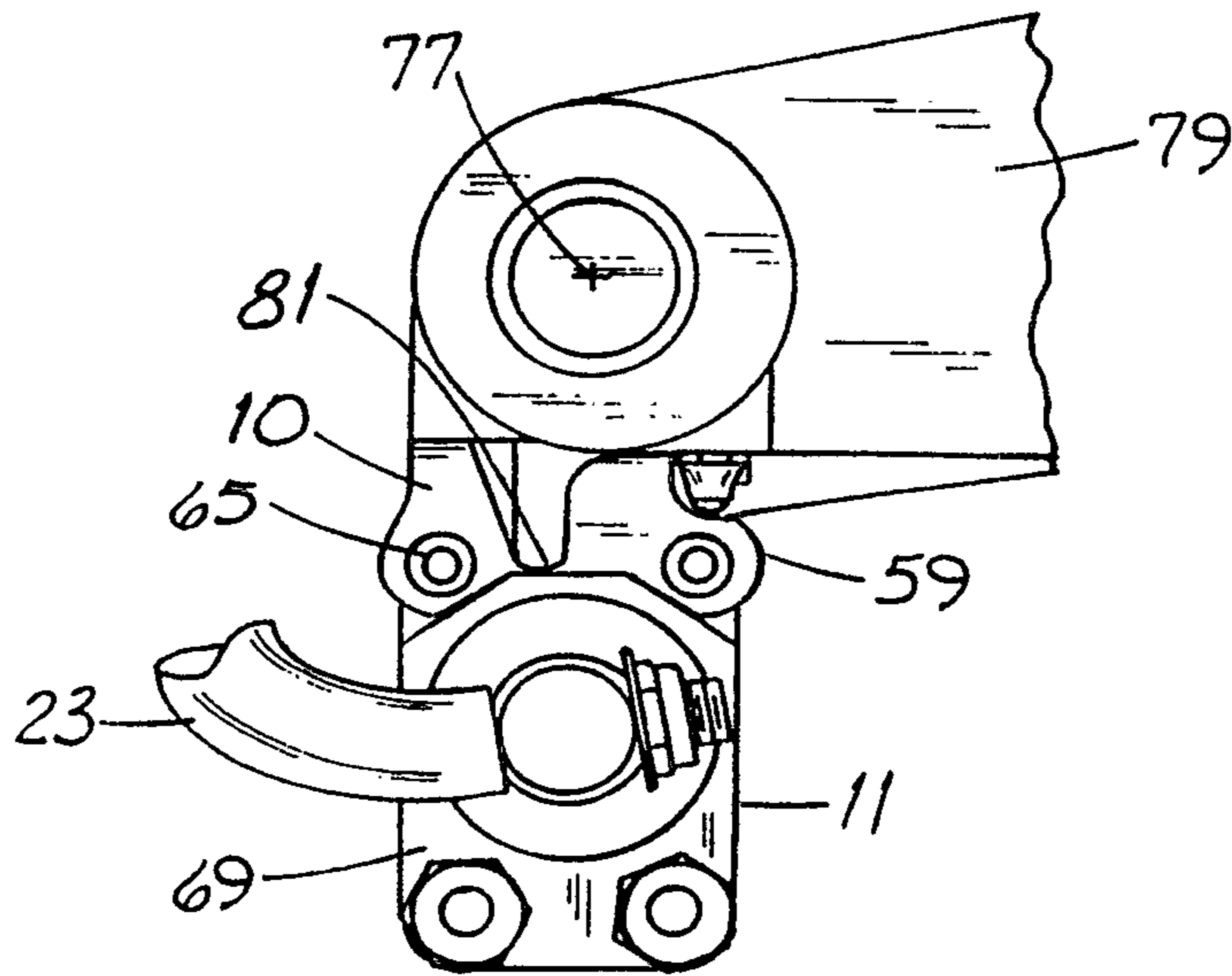

FIG. 12

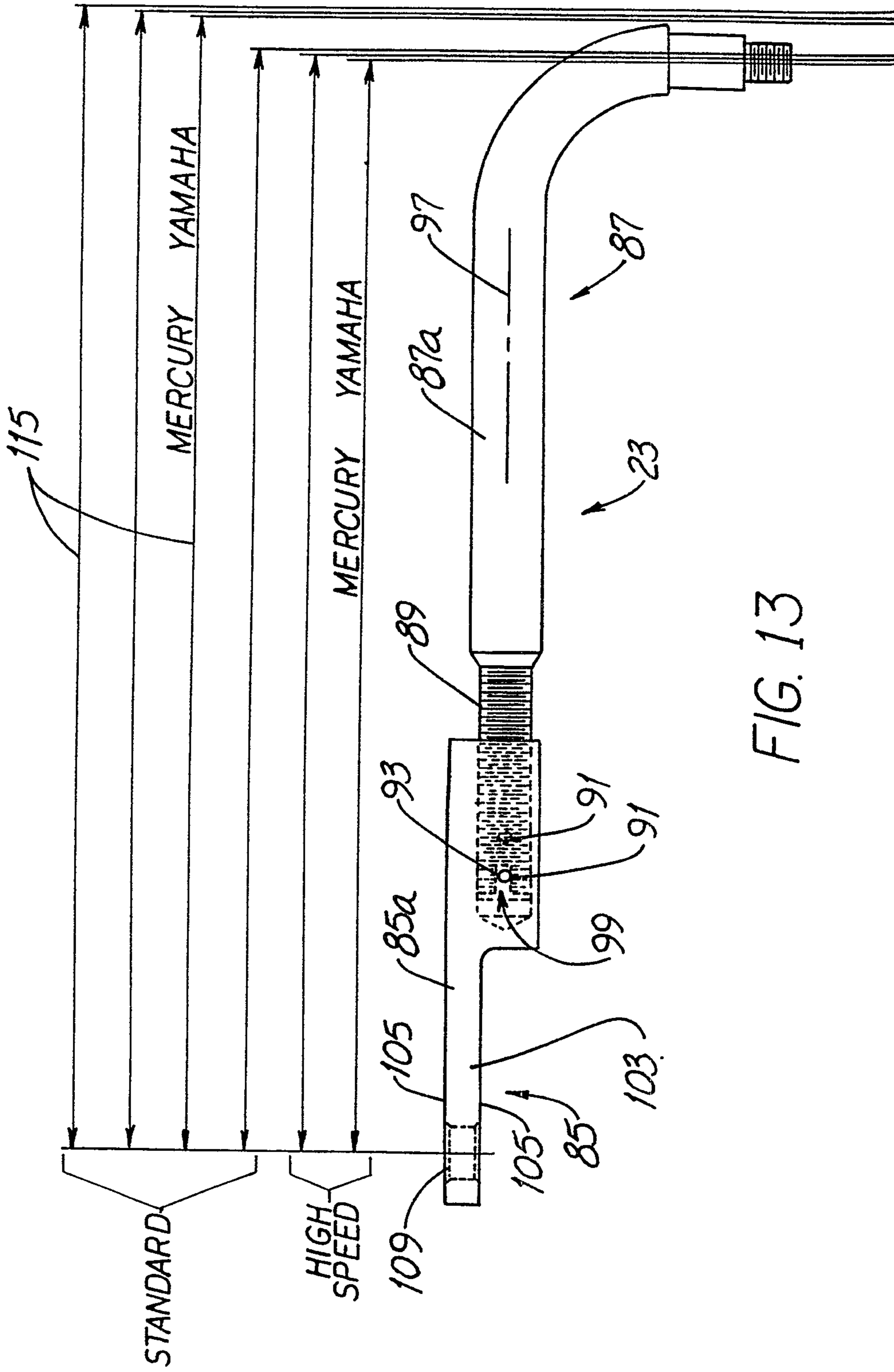

FIG. 13

