

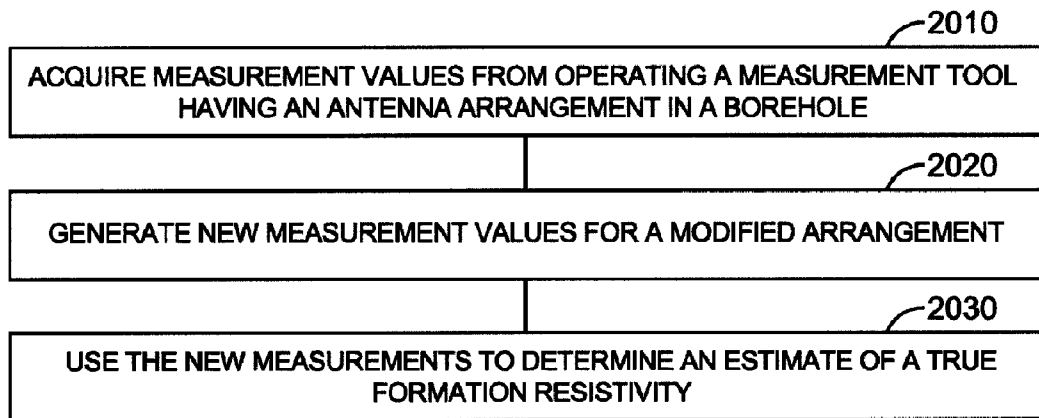

(86) **Date de dépôt PCT/PCT Filing Date:** 2013/01/30
 (87) **Date publication PCT/PCT Publication Date:** 2014/08/07
 (45) **Date de délivrance/Issue Date:** 2020/11/10
 (85) **Entrée phase nationale/National Entry:** 2015/06/18
 (86) **N° demande PCT/PCT Application No.:** US 2013/023826
 (87) **N° publication PCT/PCT Publication No.:** 2014/120150

(51) **Cl.Int./Int.Cl.** *G01V 3/18* (2006.01),
G01V 3/26 (2006.01)
 (72) **Inventeurs/Inventors:**
WU, HSU-HSIANG, US;
BITTAR, MICHAEL S., US
 (73) **Propriétaire/Owner:**
HALLIBURTON ENERGY SERVICES, INC., US
 (74) **Agent:** PARLEE MCLAWS LLP

(54) **Titre :** DETERMINATION DE LA RESISTIVITE REELLE D'UNE FORMATION
 (54) **Title:** DETERMINATION OF TRUE FORMATION RESISTIVITY



(57) **Abrégé/Abstract:**

Various embodiments include apparatus and methods to determine true formation resistivity. Such apparatus and methods may use techniques to effectively reduce or eliminate polarization horn effects at boundaries between formations of different resistivity. The techniques may use combinations of geosignals and adjustments of measurement data to evaluate true formation resistivity for formation layers investigated. Such techniques and associated analysis may be conducted real time. Additional apparatus, systems, and methods are disclosed.



Bureau canadien des brevets

Canadian Patent Office

Certificat de correction

Certificate of Correction

Canadian Patent No. 2,895,671
Granted: 10 November 2020 (10-11-2020)

Les corrections suivantes sont faites en raison de
l'article 109 des *Règles sur les brevets* et le brevet
doit être lu tel que corrigé.

The following corrections are made pursuant to
section 109 of the *Patent Rules* and the patent
should read as corrected.

In the Patent Grant:

**Pages 38 and 44 of the claims should be
read as attached pages 38 and 44.**

10 February 2021 (10-02-2021)

Date

respect to a longitudinal axis of the electromagnetic tool, and
wherein the first receiver and the transmitter are axially separated;
generating a signal with the transmitter;

measuring voltage values from the first receiver based on a measurement
by the first receiver of the signal, wherein measuring voltage values from the
first receiver comprises making measurements during a rotation of the
electromagnetic tool, the rotation of the electromagnetic tool partitioned into a
number of bins, in which completion of the number of bins is one complete
rotation of the electromagnetic tool, wherein the number of bins is greater than
one;

determining an average phase resistivity from the voltage values;

determining whether the electromagnetic tool is near a boundary based
on geosignal responses;

based on the electromagnetic tool being near the boundary, physically
adjusting at least one of a tilt angle of the transmitter or the first tilt angle;

determining new voltage values from the first receiver;

determining a new average phase resistivity measurement based on the
new voltage values; and

determining the true formation resistivity based on the new average
phase resistivity measurement.

15. The method of claim 14, further comprising a second receiver, wherein
the second receiver has the first tilt angle, and wherein the transmitter is non-
tilted.

16. The method of claim 14, further comprising a second receiver, wherein
the second receiver has the first tilt angle, and wherein the transmitter is
perpendicular to the first receiver and the second receiver.

17. The method of claim 1, wherein:

determining average phase resistivity measurements based on the
voltage values, wherein each of the voltage values are based on one of a plurality
of antenna pairs, wherein the each of the plurality of antenna pairs comprises the

receiver comprises a receiver antenna at a first tilt angle with respect to a longitudinal axis of the electromagnetic tool, and wherein the first receiver and the transmitter are axially separated;

one or more processors; and

a non-transitory machine-readable medium having program code executable by the one or more processors to :

generate a signal with the transmitter;

measure voltage values from the first receiver based on a measurement by the first receiver of the signal, wherein measuring voltage values comprises making measurements during a rotation of the electromagnetic tool, the rotation of the electromagnetic tool partitioned into a number of bins, in which completion of the number of bins is one complete rotation of the electromagnetic tool, wherein the number of bins is greater than one;

determine an average phase resistivity measurement based on the voltage values;

determine whether the average phase resistivity measurement corresponds to the true formation resistivity;

based on the average phase resistivity measurement not corresponding to the true formation resistivity, physically adjust at least one of a tilt angle of the transmitter and the first tilt angle;

measure new voltage values from the first receiver;

determine a reevaluated average phase resistivity based on the new voltage values; and

determine the true formation resistivity based on the reevaluated average phase resistivity.

32. A system to determine a true formation resistivity using an electromagnetic tool, the system comprising:

the electromagnetic tool, wherein the electromagnetic tool comprises a transmitter attached to the electromagnetic tool, wherein the transmitter comprises a transmitter antenna, and

a first receiver attached to the electromagnetic tool, wherein the first receiver comprises a receiver antenna at a first tilt angle with respect to a

(12) INTERNATIONAL APPLICATION PUBLISHED UNDER THE PATENT COOPERATION TREATY (PCT)

(19) World Intellectual Property
Organization
International Bureau(10) International Publication Number
WO 2014/120150 A1(43) International Publication Date
7 August 2014 (07.08.2014)

- (51) **International Patent Classification:**
G01V 3/18 (2006.01) *G01V 3/26* (2006.01)
- (21) **International Application Number:**
PCT/US2013/023826
- (22) **International Filing Date:**
30 January 2013 (30.01.2013)
- (25) **Filing Language:** English
- (26) **Publication Language:** English
- (71) **Applicant:** HALLIBURTON ENERGY SERVICES, INC. [US/US]; 10200 Bellaire Blvd., Houston, Texas 77072 (US).
- (72) **Inventors:** WU, Hsu-Hsiang; 6007 Parkwood Place, Sugar Land, Texas 77479 (US). BITTAR, Michael S.; 8711 Wheatland Drive, Houston, Texas 77064 (US).
- (74) **Agents:** MADDEN, Robert B. et al.; Schwegman, Lundberg & Woessner, P.A., P.O. Box 2938, Minneapolis, Minnesota 55402 (US).
- (81) **Designated States** (unless otherwise indicated, for every kind of national protection available): AE, AG, AL, AM, AO, AT, AU, AZ, BA, BB, BG, BH, BN, BR, BW, BY, BZ, CA, CH, CL, CN, CO, CR, CU, CZ, DE, DK, DM,

DO, DZ, EC, EE, EG, ES, FI, GB, GD, GE, GH, GM, GT, HN, HR, HU, ID, IL, IN, IS, JP, KE, KG, KM, KN, KP, KR, KZ, LA, LC, LK, LR, LS, LT, LU, LY, MA, MD, ME, MG, MK, MN, MW, MX, MY, MZ, NA, NG, NI, NO, NZ, OM, PA, PE, PG, PH, PL, PT, QA, RO, RS, RU, RW, SC, SD, SE, SG, SK, SL, SM, ST, SV, SY, TH, TJ, TM, TN, TR, TT, TZ, UA, UG, US, UZ, VC, VN, ZA, ZM, ZW.

- (84) **Designated States** (unless otherwise indicated, for every kind of regional protection available): ARIPO (BW, GH, GM, KE, LR, LS, MW, MZ, NA, RW, SD, SL, SZ, TZ, UG, ZM, ZW), Eurasian (AM, AZ, BY, KG, KZ, RU, TJ, TM), European (AL, AT, BE, BG, CH, CY, CZ, DE, DK, EE, ES, FI, FR, GB, GR, HR, HU, IE, IS, IT, LT, LU, LV, MC, MK, MT, NL, NO, PL, PT, RO, RS, SE, SI, SK, SM, TR), OAPI (BF, BJ, CF, CG, CI, CM, GA, GN, GQ, GW, ML, MR, NE, SN, TD, TG).

Declarations under Rule 4.17:

— of inventorship (Rule 4.17(iv))

Published:

— with international search report (Art. 21(3))

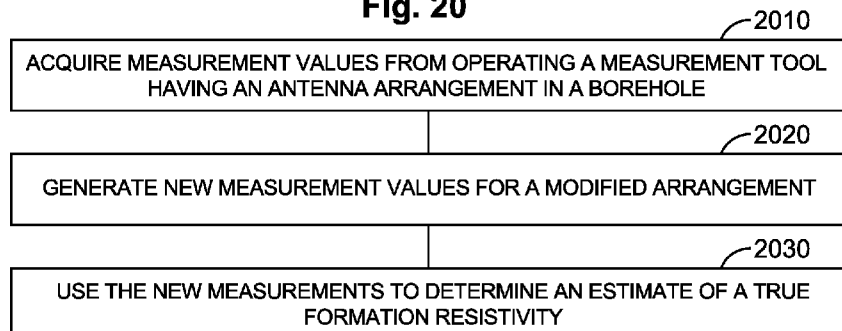
(54) **Title:** DETERMINATION OF TRUE FORMATION RESISTIVITY**Fig. 20**

(57) **Abstract:** Various embodiments include apparatus and methods to determine true formation resistivity. Such apparatus and methods may use techniques to effectively reduce or eliminate polarization horn effects at boundaries between formations of different resistivity. The techniques may use combinations of geosignals and adjustments of measurement data to evaluate true formation resistivity for formation layers investigated. Such techniques and associated analysis may be conducted real time. Additional apparatus, systems, and methods are disclosed.



WO 2014/120150 A1

Determination of True Formation Resistivity

Technical Field

The present invention relates generally to apparatus and methods related
5 to oil and gas exploration.

Background

In drilling wells for oil and gas exploration, understanding the structure
and properties of the associated geological formation provides information to aid
10 such exploration. True formation resistivity is a key petrophysical parameter
that helps petrophysicists to characterize and develop a reservoir. A resistivity
measurement presents an electrical property of formations surrounding the
logging tools, where different formations have distinct and unique resistivity
readings. For example, a salt water formation presents a low resistivity reading
15 and an oil reservoir presents a high resistivity reading. A continuous resistivity
log allows petrophysicists to recognize formation geology and to develop a good
wellbore placement program for maximum oil production in the reservoir.
However, a resistivity measurement is often problematic in layered formations,
especially while the logging tool is near the boundary between the layers, each
20 with different resistivity value. Such boundary effects, known as polarization
horn effects, can produce significant responses to conventional propagation
electromagnetic (EM) wave tools and unrealistic resistivity reading with very
high value may be measured. Consequently, misinterpretation of formation
geology may occur based on such resistivity measurements.

25 In general, one-dimensional (1D) inversion is often used to eliminate
such horn effects and explore the true formation resistivity profiles. Inversion
operations can include a comparison of measurements to predictions of a model
such that a value or spatial variation of a physical property can be determined.
In inversion, measured data may be applied to construct a model that is
30 consistent with the data. For example, an inversion operation can include
determining a variation of electrical conductivity in a formation from
measurements of induced electric and magnetic fields. Other techniques, such as

a forward model, deal with calculating expected observed values with respect to an assumed model. In zero-dimensional (0D) inversion, there is no variation in the formation, such as in a homogenous formation. In 1D modeling, there is variation in one direction such as a formation of parallel layers. In two
5 dimensional (2D) modeling, there is variation in two directions. In three dimensional (3D) modeling, there is variation in three directions. However, inversion schemes can be complicated and can have several uncertainties, such as initial formation model, number of input signals for the inversion, etc., that may cause different inverted results. The usefulness of such traditional
10 measurements and inversion analysis may be related to the precision or quality of the information derived from measurements and processes to evaluate the information.

Brief Description of the Drawings

15 Figure 1 shows a block diagram of an example system to determine formation resistivity, according to various embodiments.

Figure 2 illustrates an electromagnetic tool located in a homogeneous formation medium, according to various embodiments.

20 Figure 3A shows an example of phase attenuation conversion charts, according to various embodiments.

Figure 3B shows an example of attenuation conversion charts, according to various embodiments.

Figure 4 illustrates an electromagnetic tool equipped with a tilted antenna design, according to various embodiments.

25 Figure 5 depicts a three-layer isotropic formation model, according to various embodiments.

Figure 6 shows a configuration of an electromagnetic measurement tool equipped with symmetrical antenna structures, according to various embodiments.

30 Figure 7A shows compensated average phase resistivity measurements of two measurement tools in the formation model of Figure 5 with relative dip angle of 85° , according to various embodiments.

Figure 7B shows compensated average attenuation resistivity measurements of two tools in the formation model of Figure 5 with relative dip angle of 85° , according to various embodiments.

5 Figure 8A shows compensated average phase measurements of the tool structure in Figure 6 with non-tilted transmitters and various tilted receivers in formation model of Figure 5 with relative dip angle of 85° , according to various embodiments.

Figure 8B Compensated average attenuation resistivity measurements of the tool structure in Figure 6 with non-tilted transmitters and various tilted
10 receivers in formation model of Figure 5 with relative dip angle of 85° , according to various embodiments.

Figure 9A shows compensated average phase measurements of the tool structure in Figure 6 with non-tilted transmitters and various tilted receivers in formation model of Figure 5 with relative dip angle of 75° , according to various
15 embodiments.

Figure 9B shows compensated average attenuation resistivity measurements of the tool structure in Figure 6 with non-tilted transmitters and various tilted receivers in formation model of Figure 5 with relative dip angle of 75° , according to various embodiments.

20 Figure 10A shows compensated average phase measurements of the tool structure in Figure 6 with various orientations of the transmitters and the receivers in formation model of Figure 5 with relative dip angle of 85° , according to various embodiments.

Figure 10B shows compensated average attenuation resistivity
25 measurements of the tool structure in Figure 6 with various orientations of the transmitters and the receivers in formation model of Figure 5 with relative dip angle of 85° , according to various embodiments.

Figure 11 shows a configuration of a measurement tool's azimuthal angle at each bin direction, according to various embodiments.

30 Figures 12A-12C show tool antenna structures and defined quadrants for tools arranged with antennas having tilted angles, according to various embodiments.

Figures 13A-13C show tool antenna structures to provide similar functionalities as structures in Figures 12A-12B, according to various embodiments.

5 Figures 14A-14C show tool antenna structures to provide compensated resistivity measurements with respect to arbitrary tilted transmitter(s) and tilted receiver(s), according to various embodiments.

Figure 15 shows a configuration of a measurement tool structured to provide deep azimuthal resistivity measurements, according to various embodiments.

10 Figure 16A shows compensated average phase resistivity responses from the measurement tool of Figure 15 for two specific tilted receivers, according to various embodiments.

Figure 16B shows a geosignal phase image from the measurement tool of Figure 15, according to various embodiments.

15 Figure 17 shows a flowchart of an example processing scheme to determine true formation resistivity, according to various embodiments.

Figure 18 shows a flowchart of an example processing scheme to determine true formation resistivity, according to various embodiments.

20 Figure 19A shows compensated average phase measurements of the tool structure in Figure 6 with various orientations of the transmitters and the receivers in formation model of Figure 5 with relative dip angle of 0° , according to various embodiments.

25 Figure 19B shows compensated average attenuation resistivity measurements of the tool structure in Figure 6 with various orientations of the transmitters and the receivers in formation model in Figure 5 with relative dip angle of 0° , according to various embodiments.

Figure 20 shows features of an example method to determine true formation resistivity, in accordance with various embodiments.

30 Figure 21 shows features of an example method to determine true formation resistivity, in accordance with various embodiments.

Figure 22 shows features of an example method to determine true formation resistivity, in accordance with various embodiments.

Figure 23 shows features of an example method to determine true formation resistivity, in accordance with various embodiments.

Figure 24 depicts a block diagram of features of an example system operable to determine true formation resistivity, in accordance with various
5 embodiments.

Figure 25 depicts an embodiment of a system at a drilling site, where the system includes an apparatus operable to determine true formation resistivity, in accordance with various embodiments.

10 Detailed Description

The following detailed description refers to the accompanying drawings that show, by way of illustration and not limitation, various embodiments in which the invention may be practiced. These embodiments are described in sufficient detail to enable those skilled in the art to practice these and other
15 embodiments. Other embodiments may be utilized, and structural, logical, and electrical changes may be made to these embodiments. The various embodiments are not necessarily mutually exclusive, as some embodiments can be combined with one or more other embodiments to form new embodiments. The following detailed description is, therefore, not to be taken in a limiting
20 sense.

Figure 1 shows a block diagram of an embodiment of a system 100 operable to determine formation resistivity. The system 100 includes a measurement tool 105 operable in a well. The measurement tool 105 has an arrangement of sensors 111-1, 111-2 . . . 111-(N-1), 111-N along a longitudinal
25 axis 117 of measurement tool 105. Each sensor 111-1, 111-2 . . . 111-(N-1), 111-N can be utilized as a transmitting sensor or a receiving sensor under the control of a control unit 115. The transmitting sensors and receiving sensors can be realized as transmitter antennas and receiver antennas. The sensors 111-1, 111-2 . . . 111-(N-1), 111-N may be arranged as a plurality of groups, where
30 each group includes a transmitter sensor and a receiver sensor spaced apart by a separation distance. Sensors disposed in the various groups can be structured in a number of ways that may depend on the application of the measurement tool

105 in a measurement process. Each group can include tilted antennas and non-tilted antennas. Each group can include a grouping of a number of transmitter sensors and a number of receiver sensors. For example, each group can include, but is not limited to, a grouping of two transmitters and two receivers. The two
5 transmitters and the two receivers in a grouping can be arranged with a symmetrical orientation. Sensors that are tilted can be arranged with respect to a longitudinal axis 117. Groups having different separation distances between transmitting sensors and receivers can be used to investigate formations over different distances from the measurement tool 105. The larger separation
10 distance corresponds to investigating formations over larger distances from the tool.

The control unit 115 is operable to manage generation of a probe signal from the transmitter sensor from each group and collection of received signals in the respective group, where the received signals can be acquired relative to a
15 rotation of the measurement tool 105. The rotation of the measurement tool 105 can be partitioned into N segments, called bins, in which completion of the N bins is one complete rotation of the tool, $N \geq 2$, where N is the total number of bins. Each bin has an associated azimuthal angle φ . In various applications, N can be equal to 32. However, N can be set to other values. The received signals
20 can correspond to the bins associated with the measurement tool 105. The control unit 115 is operable to select one or more transmitter sensors from among the sensors in the arrangement of the sensors 111-1, 111-2 . . . 111-(N -1), 111- N and to select one or more receiver sensors from among the sensors in the arrangement of the sensors 111-1, 111-2 . . . 111-(N -1), 111- N . System 100 can
25 include a processing unit 120 to process the received signals to determine the formation resistivity, which can include evaluating the validity of the measured formation resistivity.

The processing unit 120 can be structured to control and process measurement values from operating the measurement tool 105. The processing
30 unit 120 can be structured to acquire measurement values from operating the measurement tool 105 in a borehole corresponding to drilling at a dip angle greater than zero. The measurement tool 105 once structured with transmitter

antennas and receiver antennas and deployed may have a fixed arrangement of transmitter and receiver antennas. The fixed arrangement can include transmitter antennas and receiver antennas at fixed distances from each other with tilt angles with respect to the longitudinal axis of the measurement tool 105. Non-tilted
 5 antennas have a tilt angle of 0°. Tilted antennas may have a tilt angle of ranging from above 0° to near 90°. The processing unit 120 can treat the arrangement of transmitter and receiver angles as having antennas whose tilt angle can operably be adjusted. With the deployed the measurement tool 105 having fixed tilt
 10 antennas whose tilt angle can operably be adjusted effectively defines a virtual arrangement of the same transmitter and receiver antennas.

Instructions stored of the processing unit 120 can be executed to generate new measurement values for the virtual arrangement of the same transmitter and receiver antennas by processing the measurement values from operating the
 15 measurement tool, where the processing uses a relationship including a tilt angle of a receiver antenna in the fixed arrangement that is different from a tilt angle of the same receiver antenna in the virtual arrangement. The new measurements can be used in the processing unit 120 to determine an estimate of a true formation resistivity of the formation being investigated. In an embodiment,
 20 from acquiring values from making measurements during a rotation of the measurement tool relative to N bins, the processing unit 120 can generate new measurement values, which can include generating $V_{R_{ind}}^{T_{ind}'}(i)$ according to

$$V_{R_{ind}}^{T_{ind}'}(i) = V_{R_{ind}}^{T_{ind}}(i) \times \frac{\sin \theta_{r2}}{\sin \theta_{r1}} + \frac{2}{N} \sum_{i=1}^N V_{R_{ind}}^{T_{ind}}(i) \times \frac{\sin(\theta_{r1} - \theta_{r2})}{\sin(2\theta_{r1})}, \quad i = 1, 2, \dots, N \quad (1)$$

for the fixed arrangement having two receiver antennas and two transmitter
 25 antennas, where T_{ind} indicates different available transmitter(s) and R_{ind} indicates different available receiver(s) and $V_{R_{ind}}^{T_{ind}}(i)$ is the signal measured at receiver R_{ind} , in response to a signal being transmitted from transmitter T_{ind} , in bin i , $i=1 \dots N$, and $V_{R_{ind}}^{T_{ind}'}(i)$ is the new measurement value for the receiver antenna R_{ind} at tilt angle θ_{r2} in the virtual arrangement with the receiver antenna
 30 R_{ind} at tilt angle θ_{r1} in the fixed arrangement at which the measurement values

from operating the measurement tool are acquired.

The processing unit 120 can be used with a number of antenna arrangements to generate new measurement values via a transformation procedure. For example, in the fixed arrangement and in the virtual
 5 arrangement, two transmitters are non-tilted. Alternatively, the two transmitters can be tilted in the fixed arrangement such that two transmitters are perpendicular to two receivers. For transmitters having tilted antennas, generating new measurement values can include determining coupling components to calculate $V_{R_{ind}}^{T_{ind}}(i)$ from which $V_{R_{ind}}^{T_{ind}}(i)$ is generated. The fixed
 10 arrangement can include two transmitters or two receivers arranged such that separation between each transmitter and each receiver is at a fixed distance.

The transformation procedure performed by the processing unit 120 can be implemented to avoid the polarization horn effects. As noted, polarization horn effects occur when a measurement tool is near a boundary between
 15 formation layers of different resistivity. Determination that the measurement tool 105 is near a boundary may be used to initiate the transformation procedure. Proximity to a boundary between formation layers can be provided by use of geosignals.

Geosignals are indicative of the direction of drilling tools downhole as well as being capable of detecting boundaries. Capabilities of geosignals are
 20 useful in geosteering to optimize well placement for maximum oil recovery. Apparatus and processing schemes, as discussed herein, allow for the generation of a geosignal. A geosignal may be based one or more properties of earth formations as a function of distance from a reference point. The geosignals
 25 defined herein have a variety of applications. Geosignals also provide azimuthal orientation information of rotary tools. In addition, the geosignal can be used for the calculation of distance to bed boundaries.

Geosignals can be defined in a number of ways. For example, two kinds of geosignal definitions, V_{Geo1} and V_{Geo2} , have been used with respect to a signal
 30 acquired at a receiver in response to a signal transmitted from a transmitter. Geosignal V_{Geo1} can be defined by

$$V_{Geo1}(i) \equiv \frac{V_R^T(\phi_i)}{\frac{1}{N} \sum_{i=1}^N V_R^T(\phi_i)}, i = 1, \dots, N \quad (2)$$

and geosignal V_{Geo2} can be expressed as

$$V_{Geo2}(i) \equiv \frac{V_R^T(\phi_i)}{V_R^T(\phi_j)}, i = 1, \dots, N. \quad (3)$$

In these geosignals, i is the index of bin number of a rotating tool, ϕ_i is the
 5 corresponding azimuthal angle from high side to the bin with index i as shown in
 Figure 11, ϕ_j is the azimuthal angle of bin j opposite to the azimuthal direction
 of bin i , that is, 180 degrees from bin i , and N is the total number of bins in
 Figure 11. The geosignal can be used as corresponding geosignal phase and
 geosignal attenuation. For example, V_{Geo2} can provide

$$10 \quad Phase_{Geo}(\phi_i) = phase\{V_R^T(\phi_i)\} - phase\{V_R^T(\phi_i + \pi)\} \text{ and} \quad (4)$$

$$A_{Geo}(\phi_i) = \log|V_R^T(\phi_i)| - \log|V_R^T(\phi_i + \pi)|. \quad (5)$$

At the distances where the measured resistivity is essentially the true resistivity,
 the measurement tool 105 is in a homogenous region and the phase of the
 geosignals is zero.

15 The processing unit 120 transforming measurement values from an
 antenna arrangement having a deployed set of tilt antennas to measurement
 values corresponding to the antennas at a different set of tilt angles allows an
 estimate of true formation resistivity to be determined without using an inversion
 procedure. Alternatively, this estimate using the transformation procedure can
 20 be used as a starting point for an in-depth inversion process such that an inverted
 geology formation may be optimized. In either case, use of this transformation
 process can provide for enhanced accuracy of resistivity measurements and for
 avoidance of polarization horn effects. In addition, the overall procedure to
 provide a true formation resistivity can be conducted as a real time determination
 25 of true formation resistivity. The processing unit 120 can be structured to
 perform in a manner similar to or identical to processes and procedures
 discussed herein.

In various embodiments, the measurement tool 105 can be implemented

in measurements-while-drilling (MWD) applications such as a logging-while-drilling (LWD) tool. The control unit 115 and the processing unit 120 can be integrated in housings operable in a well along with the plurality of antennas. Tool electronics can be placed inside a collar in a drill string on which the tool is
5 mounted. The measurement tool 105 can be implemented in a wireline application having instrumentality to rotate the measurement tool 105.

In various embodiments, a technology having processes to eliminate horn effects on resistivity measurements can be used on LWD propagation wave resistivity measurements. Methods discussed herein include procedures to attain
10 true formation resistivity readings in real time applications via azimuthal LWD tools. The techniques herein are also suitable for appropriately structured sensors that provide deep azimuthal resistivity measurements including tools with tilted transmitters that can perform deep azimuthal resistivity measurements. These procedures can be applied to other measurement tools
15 such as wireline tools.

Figure 2 illustrates an electromagnetic tool located in a homogeneous formation medium. Propagation EM wave resistivity tools often use resistivity conversion tables to interpret formation resistivity. A conventional resistivity conversion table is created on the basis of complex voltage signals received at
20 two receivers associated with a firing of a transmitter. With the firing of the transmitter T_x in Figure 2, two receivers R_1 and R_2 measure two complex voltage signals, V_{R1} and V_{R2} , respectively, that varies while the formation resistivity value (R_t) changes. Using the phase part and the attenuation part of the ratio of V_{R2} to V_{R1} with respect to distinct values of R_t , corresponding phase and
25 attenuation conversion tables can be obtained. Figures 3A-3B display an example of phase and attenuation conversion tables when operating a tool with non-tilted transmitter and non-tilted receivers in Figure 2 at frequency of 2 MHz, where spacing d_1 is 12 inch and spacing d_2 is 20 inch. Consequently, raw measurements of such propagation wave tools can be transformed into phase and
30 attenuation resistivity reading based on the charts in Figures 3A-3B.

With the introduction of tilted antenna designs, phase and attenuation resistivity conversion tables are also available for the tool design in Figure 4.

Such tilted antenna designs can produce azimuthal sensitive resistivity measurements as well as azimuthal geosignal responses. The azimuthal measurements are capable of determining tool's drilling direction as well as indicating tool's azimuthal orientation. Related applications, such as

5 geosteering, distance to bed boundary, formation anisotropy detection, etc., can all be based on such azimuthal sensitivity measurements such as with the tool design in Figure 4.

Resistivity measurements present resistivity measurements surrounding the logging tool, but the measurements become problematic when the tool is near

10 the boundary between layers with different resistivity values. An unreasonable resistivity reading may occur during horizontal drilling activity with high relative dip angle and high resistivity contrast between the layers. Consider a three-layer isotropic formation model as an example, shown in Figure 5. Both the topmost layer and the lowest layer have true formation resistivity of $1 \Omega \cdot m$,

15 and the middle layer has a high resistivity of $20 \Omega \cdot m$. The upper boundary between the topmost layer and the middle layer is at true vertical depth (TVD) of 10 ft and the lower boundary is at TVD of 20 ft, indicating that only 10 ft thickness for the middle layer. In the model, the layers are shown as parallel to

20 the horizon with the magnitude of the inclination of a plane corresponding to drilling direction from horizontal given as the dip. However, formation layers or beds may not be parallel to the horizontal such as the surface. A relative dip angle can be defined as the angle between a line normal to the plane of a bed and the direction of the drilling path or borehole.

Compensated signals were simulated for an EM tool with symmetrical

25 structures as shown in Figure 6. The symmetric EM tool has two transmitters both tilted at θ_t and two receivers both tilted at θ_r . The tilt angle θ_t and θ_r are defined based on the quadrants in Figure 6, where the z direction is tool's drilling direction and the x direction is often determined by magnetometer or gravity devices. With an operating frequency of 2 MHz, spacing (S_1) of 8 inches

30 between receivers, and spacing (S_2) of 16 inches from a transmitter to the center of the two receivers, Figures 7A-7B demonstrate the average phase and attenuation resistivity responses when two commercial LWD tools are operated

in the formation model in Figure 5 with the relative dip angle of 85° . One of the two tools was equipped with all non-tilted antenna loops and the other tool was installed with tilted central receivers ($\theta_r = 45^\circ$) and non-tilted transmitters.

As illustrated in Figures 7A-7B, the measurements from both tools are essentially the same such that basically only one curve is shown in each of Figures 7A-7B. Both tools measure good resistivity reading consistent with true formation resistivity, while the tools are away from the boundaries. However, resistivity reading becomes unrealistic and do not present true formation resistivity value at and near a boundary. Using such unrealistic measurements without performing a 1D inversion, misinterpretation of formation geology can occur.

In various embodiments, techniques are implemented to directly determine true formation resistivity without running a 1D inversion. First, sets of measurements were considered with an arrangement of the measurement tool in Figure 6 with the transmitters' tilt angle fixed to be 0° and the receivers' tilt angle adjusted from 0° to 85° . Similar to Figures 7A-7B with the same formation parameters in Figure 5 and relative dip angle of 85° , average resistivity measurements were computed with respect to several specific orientations of the receivers with non-tilted transmitters. Figure 8A shows compensated average phase measurements of the tool structure in Figure 6 with non-tilted transmitters and various tilted receivers in formation model of Figure 5 with relative dip angle of 85° . The group 841 of results includes non-tilted transmitters and receivers having tilt angles of 5° , 15° , 25° , 35° , and 45° . Curves 842, 844, 846, and 848 of results are for non-tilted transmitters and receivers having tilt angles of 55° , 65° , 75° , and 85° , respectively. Figure 8B shows compensated average attenuation resistivity measurements of the tool structure in Figure 6 with non-tilted transmitters and various tilted receivers in formation model of Figure 5 with relative dip angle of 85° . The group 851 of results includes non-tilted transmitters and receivers having tilt angles of 5° , 15° , 25° , 35° , and 45° . Curves 852, 854, 856, and 858 of results are for non-tilted transmitters and receivers having tilt angles of 55° , 65° , 75° , and 85° , respectively. The results provide conclusions that some receiver orientations

produce very good phase resistivity measurements with no polarization horns and close to true formation resistivity value; on the other hand, at the same receiver orientations, corresponding attenuation resistivity measurements enhance horn effects while the measurement tool is relatively far away from the
5 boundaries.

For example, the tool structure with 85° tilted receivers develops average phase resistivity reading similar to the true resistivity in layers with resistivity value of 1Ω·m, whereas, in the middle layer with resistivity value of 20Ω·m, the tool structure with 65° tilted receivers gives average phase resistivity reading
10 close to the formation model. On the other hand, attenuation resistivity responses of the structure with 85° tilted receivers incur a horn effect before the measurement tool passes the boundaries. For example, the horn effect for this structure occurs approximately 0.65 ft before the boundary when tool is located in the 1Ω·m formation and approximately 0.98 ft before the boundary when tool
15 is located in the 20Ω·m formation. Consequently, by adjusting the orientations of the receivers, the corresponding phase resistivity measurements can be used to denote true formation resistivity reading and the corresponding attenuation resistivity can be utilized to figure out boundary positions.

Figures 9A-9B show the resistivity measurements for the relative dip
20 angle being 75°. Figure 9A shows compensated average phase measurements of the tool structure in Figure 6 with non-tilted transmitters and various tilted receivers in formation model of Figure 5 with relative dip angle of 75°. The group 941 of results includes non-tilted transmitters and receivers having tilt angles of 5°, 15°, 25°, 35°, and 45°. Curves 942, 944, 946, and 948 of results
25 are for non-tilted transmitters and receivers having tilt angles of 55°, 65°, 75°, and 85°, respectively. Figure 9B shows compensated average attenuation resistivity measurements of the tool structure in Figure 6 with non-tilted transmitters and various tilted receivers in formation model of Figure 5 with relative dip angle of 75°. The group 951 of results includes non-tilted
30 transmitters and receivers having tilt angles of 5°, 15°, 25°, 35°, and 45°. Curves 952, 954, 956, and 958 of results are for non-tilted transmitters and receivers having tilt angles of 55°, 65°, 75°, and 85°, respectively. Again, changing

receiver orientations has no influence on resistivity measurements if the measurement tool is far away from the boundaries, whereas it enables different resistivity reading nearby the boundary. Such findings can be utilized to directly evaluate true formation resistivity and detect boundary positions.

5 In addition, it has been discovered that resistivity measurements calculated by traditional conversion charts can be also acquired by antenna structures where transmitter(s)' orientations are perpendicular to receiver(s)' orientations. Figures 10A-10B show the compensated phase and attenuation resistivity responses at relative dip angle of 85° of two perpendicular
10 arrangements between the transmitter(s) and the receiver(s), where one arrangement has the transmitters' tilt angle of -45° and the receivers' tilt angle of 45° (curves 1042 and 1052) and the other arrangement has the transmitters' tilt angle of 5° and the receivers' tilt angle of -85° (curves 1044 and 1054). Figures 10A-10B also compares the resistivity responses of another two
15 structures where both are equipped with non-tilted transmitters but the receivers are tilted at two different tilt angles (curves 1046 and 1056 for receiver tilt angle of 45° and curve 1048 and 1058 for receiver tilt angle of 85°). As illustrated in Figures 10A-10B, similar conclusions reveal that phase resistivity measurements of specific antenna orientations significantly reduce or eliminate resistivity horn
20 effects and accurately estimate true formation resistivity; conversely, attenuation resistivity measurements of the same antenna orientations emphasize horn effects and early discovery of nearby boundaries.

The findings discussed above were made with respect to two kinds of tool structures and corresponding simulations that were performed. One tool
25 structure is equipped with non-tilted transmitters and tilted central receivers, and the other structure is established by both tilted transmitters and tilted receivers with perpendicular arrangements between the transmitter(s) and the receiver(s). Owing to reciprocity theorem, all the described transmitters and receivers can be exchangeable. Consequently, similar simulation results and conclusions can be
30 obtained if a transmitter becomes a receiver or a receiver becomes a transmitter.

Consider the tool structure of Figure 6 with non-tilted transmitters and arbitrary tilted receivers. With a firing of the transmitters (T_1 or T_2), the voltage

received at one of the two central receivers can be written as:

$$V_{R_{ind}}^{T_{ind}}(\phi) = V_{zz}^{T_{ind}R_{ind}} \cos \theta_r + V_{zx}^{T_{ind}R_{ind}} \sin \theta_r \cos \phi \quad (6)$$

Where, T_{ind} indicates transmitters and R_{ind} indicates receivers (ind is 1 or 2), ϕ is tool azimuthal angle, θ_r is tilt angle of the receivers, $V_{zz}^{T_{ind}R_{ind}}$ is a coupling component when the transmitter T_{ind} is orientated in z direction and the receiver R_{ind} is orientated in z direction in Figure 6, and $V_{zx}^{T_{ind}R_{ind}}$ is a coupling component when the transmitter T_{ind} is orientated in z direction and the receiver R_{ind} is orientated in x direction in Figure 6. In practice, the measurements of a complete tool rotation are divided by N bins with each at a distinct azimuthal angle ϕ_i , as shown in Figure 11. Equation (6) can be modified as

$$V_{R_{ind}}^{T_{ind}}(i) = V_{zz}^{T_{ind}R_{ind}} \cos \theta_r + V_{zx}^{T_{ind}R_{ind}} \sin \theta_r \cos \phi_i, \quad i = 1, 2, \dots, N \quad (7)$$

where i denotes different bins defined in Figure 11. The measurement tool to make measurements in a borehole have the receivers with tilt angles fixed that cannot be randomly changed. In a measurement tool structure for LWD applications, owing to LWD rotating operation, all azimuthal measurements of a complete rotation are available during downhole drilling. Consider an EM tool with tilted receivers, having tilt angle of θ_{r1} , $\theta_{r1} \neq 0$, and non-tilted transmitters. Based on equation (7), an average of all azimuthal measurements of a complete rotation can be expressed as:

$$\frac{1}{N} \sum_{i=1}^N V_{R_{ind}}^{T_{ind}}(i) = V_{zz}^{T_{ind}R_{ind}} \cos \theta_{r1} \quad (8)$$

Equation (9) can be derived from equation (7) and equation (8) to obtain a new azimuthal measurement $V_{R_{ind}}^{\prime T_{ind}}(i)$ received at the same receiver but with different tilt angle, θ_{r2} :

$$V_{R_{ind}}^{\prime T_{ind}}(i) = V_{R_{ind}}^{T_{ind}}(i) \times \frac{\sin \theta_{r2}}{\sin \theta_{r1}} + \frac{2}{N} \sum_{i=1}^N V_{R_{ind}}^{T_{ind}}(i) \times \frac{\sin(\theta_{r1} - \theta_{r2})}{\sin(2\theta_{r1})}, \quad i = 1, 2, \dots, N \quad (9)$$

Since θ_{r1} is known and defined by the tool design, equation (9) presents an approach to calculate the new azimuthal measurements $V_{R_{ind}}^{\prime T_{ind}}(i)$ associated with the desired tilted receivers with tilt angle θ_{r2} on the basis of raw

measurements $V_{R_{ind}}^{T_{ind}}(i)$.

Consider the tool structure of Figure 6 with both tilted transmitters and tilted receivers with perpendicular arrangement between the transmitter(s) and the receiver(s). A measurement signal received at a receiver corresponding to
5 the transmitting signal of a transmitter can be expressed as:

$$V_{R_{ind}}^{T_{ind}}(i) = -\frac{V_{xx}^{T_{ind}R_{ind}} - V_{yy}^{T_{ind}R_{ind}}}{4} \cos 2\phi_i - \frac{V_{xy}^{T_{ind}R_{ind}} + V_{yx}^{T_{ind}R_{ind}}}{4} \sin 2\phi_i - \frac{V_{xz}^{T_{ind}R_{ind}} - V_{zx}^{T_{ind}R_{ind}}}{2} \cos \phi_i - \frac{V_{yz}^{T_{ind}R_{ind}} - V_{zy}^{T_{ind}R_{ind}}}{2} \sin \phi_i + \frac{2V_{zz}^{T_{ind}R_{ind}} - V_{xx}^{T_{ind}R_{ind}} - V_{yy}^{T_{ind}R_{ind}}}{4}, \quad i = 1, 2, \dots, N \quad (10)$$

$V_{jk}^{T_{ind}R_{ind}}$ is a coupling component when the transmitter T_{ind} is orientated in j direction and the receiver R_{ind} is orientated in k direction in Figure 6; j or k
10 denotes x , y , or z direction. Consequently, nine coupling components are essential to decouple equation (10) and then calculate new measurements of desired antenna orientations. This demonstrates that the related processing schemes are more complicated for a tool structure with tilted transmitters and tilted receivers than the tool structure with non-tilted transmitters and tilted
15 receivers.

In order to adjust both transmitter(s) and receiver(s) orientations and obtain new measurements with respect to arbitrary antenna orientations, a multi-component antenna system can be utilized. Figures 12A-12B show examples of antenna designs to achieve such purpose. The tool must be equipped with at
20 least one tilted transmitter and two tilted receivers, or one tilted receiver and two tilted transmitters, where the two antennas (either transmitters or receivers in Figures 12A-12B) are located at the same position with same distance (S) to the third antenna. Thus, one of the two antennas that are placed at the same position in Figures 12A-12B can have an arbitrary tilted angle in any quadrants of Figure
25 12C, the other must have a tilted angle in the quadrant adjacent to the quadrant in which the first antenna orientation is, and the third antenna can be tilted at arbitrary angle. For example, if θ_{r1} (or θ_{t1}) in Figures 12A-12B is in quadrant 1 of Figure 12C, θ_{r2} (or θ_{t2}) must be in either quadrant 2 or quadrant 4 of Figure 12C. In addition, Figures 13A-13C show more tool structures that having the
30 capacity to attain the same functionalities as the structures in Figures 12A-12B.

It is noted that transmitter(s) and receiver(s) can be exchangeable in both Figures 12A-12B and Figures 13A-13C. In addition, Figures 14A-14C illustrate the structures that are capable of acquiring compensated measurements with respect to arbitrary transmitter(s) and receiver(s) orientations to achieve desired resistivity measurements on the basis of the processing schemes discussed herein.

A geosignal is also an important parameter to predict when the measurement tool is approaching, leaving, or passing the boundary between layers. Figure 15 shows a configuration of a measurement tool structured to provide deep azimuthal resistivity measurements that is available as a commercial LWD tool, as an example. Figure 15 shows one spacing of 16 inches of antenna structures with non-tilted transmitters and 45° tilted receivers. Figure 16A shows compensated average phase resistivity responses from the measurement tool of Figure 15 for two specific tilted receivers having tilt angles of 85° and 65°. The compensated average phase resistivity of the structure of Figure 15 is depicted by curve 1641. Figure 16B shows a geosignal phase image from the measurement tool of Figure 15, with respect to the formation model of Figure 5 with the relative dip angle of 85°. The geosignal image for this case was provided with respect to the number of total bins per rotation being 32.

Figure 16A shows that as the measurement tool approaches the first boundary at TVD of 10 ft, at around 9.3 ft, the geosignal shows significant responses. Also, based on the positive and negative sign of the geosignal azimuthal responses, it demonstrates that drilling is from a layer with lower resistivity to a layer with higher resistivity. Consequently, at TVD of 9.3 ft, the phase resistivity can be retrieved by adjusting the tilt angle of the central receivers to 85° tilt angle using the techniques discussed herein. The new phase resistivity reading is illustrated in Figure 16A by curve 1642. After passing the first boundary, the sign of the geosignal responses changes and predicts that the tool is now located in the layer with higher resistivity value. At this moment, the phase resistivity reading can be recalculated by 65° tilt angle receivers, indicated in curve 1643, in the middle layer. While the measurement tool is passing the second boundary at TVD of 20 ft, the sign of the geosignal responses changes

again and a new phase resistivity can be determined by 85° tilted receivers, indicated in curve 1644, owing to expecting the new layer with lower resistivity value on the basis of the sign changes of the geosignal azimuthal responses. Consequently, curve 1642, curve 1643, and curve 1644 of Figure 16A can be
5 combined to estimate resistivity reading very close to true formation models and to effectively eliminate horn effects of phase resistivity reading, depicted in curve 1641, of the measurement tool structured to provide deep azimuthal resistivity measurements of Figure 15.

The tool arrangement in Figure 15 includes the transmitters being non-
10 tilted in the geosignal application discussed above to determine an estimate of true formation resistivity and to effectively eliminate horn effects. Geosignal phase image and similar processing schemes to determine true formation resistivity can be also achieved by both tilted transmitters and tilted receivers with perpendicular arrangements between the transmitter(s) and the receiver(s).
15 Other arrangements may be used that can take advantage of the tilt angle transformation scheme discussed herein.

Figure 17 shows a flowchart of an example embodiment of a processing scheme to determine true formation resistivity. At 1710, regular measurements for average phase resistivity are performed using a physical measurement tool
20 structure downhole and average phase resistivity is calculated based on this tool structure. At 1720, corresponding geosignal responses are utilized. The corresponding geosignal responses can include those generated from the measurements relative to the tool structure. At 1730, these corresponding geosignal responses are applied to determine formation models. These
25 formation models can include resistivity as a function of layer position. At 1740, a determination is made as to whether the measured resistivity is true formation resistivity or not based on the utilization of the geosignal responses. If the geosignal responses identify significant signals, there should be a boundary nearby and the resistivity reading may not be accurate. Without a boundary, the
30 geosignal responses are essentially zero. At 1750, if significant signals are identified, an adjustment to antenna orientations is identified. At 1760, the identified adjustments to the antenna orientations can be processed to transform

the measurement values from operation of the physical measurement tool structure to measurement values corresponding to the adjustments to the antenna orientations and to recalculate the average phase resistivity. The adjustment using geosignal responses may be directed to a best antenna orientation from stored data or may be an iterative process. At 1770, a determination of a true formation resistivity is made based on the use of the geosignal responses. Thus, the processing scheme can use recalculation of new average phase resistivity readings associated with specific antenna orientations based on geosignal responses. At the end, this processing scheme can obtain accurate resistivity measurements and avoid polarization horn effects.

Figure 18 shows a flowchart of an example embodiment of a processing scheme to determine true formation resistivity. At 1810, raw measurements are acquired from a measurement tool operating in a borehole with an arrangement of antennas. At 1820, multiple antenna orientations are applied to the raw measurements. These multiple antenna orientations can be used to transform the raw measurements to new measurements in accordance with techniques discussed herein. At 1830, various average phase resistivities are calculated corresponding to the multiple antenna orientations to obtain several average phase resistivity measurements. At 1840, a determination can be made as to whether these average phase resistivity measurements provide an estimate of a true formation resistivity. If no boundary effect exists, all the phase resistivity measurements should be identical, meaning the phase resistivity measurements estimate true formation resistivity. However, if differences exist among the phase resistivity measurements associated with distinct antenna orientations, standard Geosignal responses are included, at 1850, to determine a proper resistivity reading for determination of true formation resistivity at 1860.

Various transformation techniques to provide new measurement values from raw measurements similar to or identical to techniques discussed herein can be applicable to different processing schemes. Such combinations of transformation techniques and processing schemes can provide very fast and simple methodology to significantly reduce or eliminate horn effects and directly detect true formation resistivity. In addition, such combinations can be used to

attain a resistivity value that can be applied as an initial guess of 1D inversion, and afterward perform inversion to optimize the inverted formation geology.

Techniques discussed above are basically used during horizontal and deviated drilling. In vertical drilling with 0° relative dip angle, these techniques are not able to adjust antenna orientations as described above. Figure 19A shows compensated average phase measurements of the tool structure in Figure 6 with various orientations of the transmitters and the receivers in formation model of Figure 5 with relative dip angle of 0°. Figure 19B shows compensated average attenuation resistivity measurements of the tool structure in Figure 6 with various orientations of the transmitters and the receivers in formation model of Figure 5 with relative dip angle of 0°. The various orientations included non-tilted transmitters with receivers tilted at 5°, 25°, 45°, 65°, and 85° and tilted orientation pairs of $(\theta_t, \theta_r) = (45^\circ, 45^\circ), (25^\circ, 65^\circ),$ and $(5^\circ, 85^\circ)$. However, Figures 19A-19B each essentially show two curves (curves 1941 and 1943 corresponding to non-tilted transmitter arrangements and curves 1942 and 1944 corresponding to tilted transmitter arrangements), since the results for all orientations with non-tilted transmitters have essentially the same responses and the results for all orientations with both tilted transmitters and receivers have essentially identical results.

For the cases with non-tilted transmitters corresponding to drilling in a vertical well with 0° relative dip angle, the coupling component of $V_{zx}^{T_{ind}R_{ind}}$ will be null and thereby the received signal in equation (7) is revised as

$$V_{R_{ind}}^{T_{ind}}(i) = V_{zz}^{T_{ind}R_{ind}} \cos \theta_r, \quad i = 1, 2, \dots, N \quad (11)$$

Since the resistivity measurement is calculated by the ratio between the signals at the central receivers with one firing of the two transmitters in Figure 6, the ratio signal can be expressed as

$$\frac{V_{R_2}^{T_{ind}}(i)}{V_{R_1}^{T_{ind}}(i)} = \frac{V_{zz}^{T_{ind}R_2} \cos \theta_r}{V_{zz}^{T_{ind}R_1} \cos \theta_r} = \frac{V_{zz}^{T_{ind}R_2}}{V_{zz}^{T_{ind}R_1}}, \quad i = 1, 2, \dots, N \quad (12)$$

Therefore, equation (12) explains that the tilt angle of the receivers have no impact on the average resistivity measurements. On the other hand, for the cases with both tilted transmitters and tilted receivers corresponding to drilling in the

vertical well, all the cross-coupling components

($V_{xy}^{T_{ind}R_{ind}}$, $V_{yx}^{T_{ind}R_{ind}}$, $V_{xz}^{T_{ind}R_{ind}}$, $V_{zx}^{T_{ind}R_{ind}}$, $V_{yz}^{T_{ind}R_{ind}}$, and $V_{zy}^{T_{ind}R_{ind}}$) are null and the direct-coupling components of $V_{xx}^{T_{ind}R_{ind}}$ and $V_{yy}^{T_{ind}R_{ind}}$ are the same. Consequently, received signal in equation (10) can be modified as

$$5 \quad V_{R_{ind}}^{T_{ind}}(i) = \frac{V_{zz}^{T_{ind}R_{ind}} - V_{xx}^{T_{ind}R_{ind}}}{2}, \quad i = 1, 2, \dots, N \quad (13)$$

It can be seen that tools with any tilt angle of transmitters and receivers will have the same received signals during vertical drilling with very low relative dip angle. It is noted that resistivity polarization horn effects do not exist in vertical drilling (0° relative dip angle) so that conventional resistivity measurements can be directly used for geology interpretation and/or 1D formation inversion in vertical drilling (0° relative dip angle) applications. Thus, the embodiments of processing techniques described herein need not be applied for a vertical drilling (0° relative dip angle) operation.

All methods mentioned above are implemented by virtually adjusting antenna orientations to eliminate resistivity polarization horn effects in the new measurements. On the other hand, the methods can also be implemented by physically adjusting antenna orientations to attain the same results. For the physical adjustment of antenna orientations, the control unit 115 in Figure 1 can be operable to assign the desired antenna orientation to a particular transmitter or receiver sensor such that the sensor can be physically orientated. Then the processing unit 120 in Figure 1 can thereafter acquire the real measurements from the new physically orientated transmitter and receiver sensors.

In various embodiments, useful processing schemes are provided to eliminate resistivity polarization horn effects and further determine true formation resistivity. These processing schemes can be implemented using azimuthal LWD propagation wave tools. These processing schemes can provide simple and fast techniques to understand formation geology and directly compute true formation resistivity without 1D inversion, which may provide an enhancement over approaches in which resistivity horn effects often occur during horizontal drilling accompanied by misinterpretation of formation geology if a 1D inversion is not performed. Such technologies are applicable to

a number of different commercial tools. In addition, using such processing schemes may be beneficial for field operations in which 1D inversion results may be improved and related real-time applications may be optimized, such as distance to bed boundary inversion (DTBB).

5 Figure 20 shows features of an embodiment of an example method to determine true formation resistivity. At 2010, measurement values are acquired from operating a measurement tool in a borehole. The measurement tool obtaining the measurement values has an arrangement of transmitter and receiver antennas. Acquiring measurement values can include acquiring values from
10 making measurements during a rotation of the measurement tool, the rotation of the measurement tool partitioned into N bins, in which completion of the N bins is one complete rotation of the measurement tool, $N \geq 2$, where N is the total number of bins.

At 2020, new measurement values are generated for a modified
15 arrangement. The modified arrangement may be a virtual arrangement. The modified arrangement has the same transmitter and receiver antennas as the arrangement with the orientation of transmitter antennas, receiver antennas, or both the transmitter and receiver antennas adjusted from the orientation of the arrangement. The new measurement values can be generated by processing the
20 measurement values from operating the measurement tool using a relationship including the tilt angle of a receiver antenna in the arrangement and the tilt angle of the same receiver antenna in the modified arrangement, where the tilt angle of the receiver antenna in the arrangement is different from the tilt angle of the same receiver antenna in the modified arrangement. Generating new

25 measurement values can include generating $V_{R_{ind}}^{T_{ind}'}(i)$ according to

$$V_{R_{ind}}^{T_{ind}'}(i) = V_{R_{ind}}^{T_{ind}}(i) \times \frac{\sin \theta_{r2}}{\sin \theta_{r1}} + \frac{2}{N} \sum_{i=1}^N V_{R_{ind}}^{T_{ind}}(i) \times \frac{\sin(\theta_{r1} - \theta_{r2})}{\sin(2\theta_{r1})}, \quad i = 1, 2, \dots, N$$

for the arrangement having at least two or more receiver antennas and at least one or more transmitter antennas, where T_{ind} indicates different transmitters and R_{ind} indicates different receivers, $V_{R_{ind}}^{T_{ind}}(i)$ is the signal measured at receiver R_{ind} ,
30 in response to a signal being transmitted from transmitter T_{ind} , in bin i , $i=1 \dots$

N, and $V_{R_{ind}}^{T_{ind}}(i)$ is the new measurement value for the receiver antenna R_{ind} at tilt angle θ_{r2} in the modified arrangement with the receiver antenna R_{ind} at tilt angle θ_{r1} in the arrangement at which the measurement values from operating the measurement tool are acquired. The transmitters can be non-tilted in the arrangement and in the modified arrangement. The transmitters can be tilted in the arrangement such that the transmitters are perpendicular to the receivers. Generating new measurement values can include determining coupling components to calculate $V_{R_{ind}}^{T_{ind}}(i)$ from which $V_{R_{ind}}^{T_{ind}}(i)$ is generated. The arrangement can include at least one or more transmitters or at least two or more receivers arranged such that separation between each transmitter and each receiver is at a fixed distance

At 2030, the new measurements are used to determine an estimate of a true formation resistivity. The estimate of the true formation resistivity can be used as an initial guess in a one-dimensional or multi-dimensional inversion procedure such that an inverted geology formation is optimized. The method can be conducted in real time. In an embodiment, a method associated with Figure 20 can include physically adjusting the arrangement of the transmitter and the receiver antennas to form new oriented transmitter and receiver antennas; obtaining measurements from the new oriented transmitter and receiver antennas; and using the new measurements to determine the estimate of a true formation resistivity.

Figure 21 shows features of an embodiment of an example method to determine true formation resistivity. At 2110, measurement values are acquired from operating a measurement tool in a borehole. The measurement tool obtaining the measurement values has an arrangement of transmitter and receiver antennas. Acquiring measurement values can include acquiring values from making measurements during a rotation of the measurement tool, the rotation of the measurement tool partitioned into N bins, in which completion of the N bins is one complete rotation of the measurement tool, $N \geq 2$, where N is the total number of bins. At 2120, an average phase resistivity is determined from the measurement values.

At 2130, a determination is made as to whether the average phase resistivity corresponds to a true formation resistivity. Determining whether the average phase resistivity corresponds to a true formation resistivity can include determining whether the measurement tool is near a boundary when acquiring the measurement values. Geosignals can be generated from operating the measurement tool in the borehole and the geosignals can be used to determine whether the measurement tool is near a boundary when acquiring the measurement values.

At 2140, the average phase resistivity can be reevaluated with respect to a different tilt angle of a receiver in the antenna arrangement using the measurement values. The reevaluation can be based on the determination regarding true formation resistivity. Reevaluating the average phase resistivity can include transforming the acquired measurement values such that a signal corresponding to a signal at the receiver having a tilt angle in the arrangement from transmitting a signal from a transmitter in the arrangement is converted to a signal at the receiver having a different tilt angle. Transforming the acquired measurement values can include adjusting the acquired measurement values with respect to coupling components. The reevaluated average phase resistivity can be used as an initial guess in a one-dimensional or multi-dimensional inversion procedure such that an inverted geology formation is optimized. The method can be conducted in real time.

Reevaluating the average phase resistivity with respect to a different tilt angle of a receiver in the original antenna arrangement using the measurement values can include a physical adjustment to the arrangement. In an embodiment, a method can include acquiring measurement values from operating a measurement tool in a borehole, the measurement tool having an antenna arrangement; determining an average phase resistivity from the measurement values; determining whether the average phase resistivity corresponds to a true formation resistivity; physically adjusting the arrangement of the transmitter and the receiver antennas, forming new oriented transmitter and receiver antennas; obtaining measurements from the new oriented transmitter and receiver antennas; and using the new measurements to evaluate the average phase

resistivity. The average phase resistivity from new measurements can be used as an initial guess in a one-dimensional or multi-dimensional inversion procedure such that an inverted geology formation is optimized. The method can be conducted in real time.

5 Figure 22 shows features of an embodiment of an example method to determine true formation resistivity. At 2210, measurement values are acquired from operating a measurement tool in a borehole. The measurement tool obtaining the measurement values has an arrangement of transmitter and receiver antennas. Acquiring measurement values can include acquiring values from
10 making measurements during a rotation of the measurement tool, the rotation of the measurement tool partitioned into N bins, in which completion of the N bins is one complete rotation of the measurement tool, $N \geq 2$, where N is the total number of bins.

 At 2220, an average phase resistivity is calculated from the measurement
15 values. At 2230, geosignal responses are used to determine whether the measurement tool is near a boundary.

 At 2240, antenna orientations are adjusted to specific antenna orientations based on the geosignal responses. Adjusting to specific antenna orientations can be conducted virtually or physically. The specific antenna
20 orientations can be at least in part different from antenna orientations of the antenna arrangement. The antenna arrangement can include at least one or more non-tilted transmitters and at least two or more receivers having a same tilt angle and the specific antenna orientations have the at least two or more receivers with a tilt angle different from the tilt angle of the antenna arrangement. The antenna
25 arrangement can include at least one or more tilted transmitters arranged perpendicular to at least two or more receivers having a same tilt angle and the specific antenna orientations have the receivers with a tilt angle different from the tilt angle of the antenna arrangement. A voltage signal can be determined at one receiver of the receivers in response to one of the transmitters generating a
30 signal in the antenna arrangement and the voltage signal is transformed to a new voltage signal of the one receiver by processing based on the same tilt angle and a tilt angle of the specific orientation that is different from the same tilt angle.

At 2250, a new average phase resistivity is recalculated with respect to the specific antenna orientations to estimate a true formation resistivity. The recalculated new average phase resistivity can be used as an initial guess in a one-dimensional or multi-dimensional inversion procedure such that an inverted
5 geology formation is optimized. The method can be conducted in real time.

Figure 23 shows features of an embodiment of an example method to determine true formation resistivity. At 2310, measurement values are acquired from operating a measurement tool in a borehole. The measurement tool obtaining the measurement values has an arrangement of transmitter and receiver
10 antennas. Acquiring measurement values can include acquiring values from making measurements during a rotation of the measurement tool, the rotation of the measurement tool partitioned into N bins, in which completion of the N bins is one complete rotation of the measurement tool, $N \geq 2$, where N is the total number of bins.

At 2320, an average phase resistivity is calculated from the measurement values for each of a plurality of antenna orientations. The plurality of antenna orientations can include the antenna arrangement.

At 2330, the average phase resistivities can be compared to determine if the average phase resistivities estimate a true formation resistivity. Comparing
20 the average phase resistivities can include determining if magnitudes of respective differences between the average phase resistivities are greater than a threshold. The threshold can be set to zero. However, noise and imperfections can cause the threshold to be non-zero. To take such small variances into consideration, the threshold can be an error amount greater than zero.

At 2340, geosignal responses are used to determine a reading
25 corresponding to the true formation resistivity, if the comparison does not identify an estimate of the true formation resistivity. The reading corresponding to the true formation resistivity can be used as an initial guess in a one-dimensional or multi-dimensional inversion procedure such that an inverted
30 geology formation is optimized. The method can be conducted in real time.

In various embodiments, sets of measurement values from operating a measurement tool downhole can be processed as the measurement tool moves in

the borehole. Processing of the measurement values can include determining values for formation resistivity and generating geosignals. The geosignals provide an indication that the measurement is moving near a boundary between formation layers. When the presence of the boundary is determined, the

5 measurement values can be transformed to measurement values corresponding to antenna orientations of the measurement tool that reduce or eliminate the horn effect associated with the downhole measurement values. The resistivity can be recalculated for the transformed measurement corresponding to a tilt angle adjusted from that of the measurement based on the geosignal response. For

10 each boundary encountered in the movement of the measurement tool, two or more recalculations can be performed; at least one approaching the boundary and at least one leaving the boundary. The multiple recalculations can be attributed to measurement values being related to different tilt angles of the antennas of the measurement tool on the different sides of the boundary between formation

15 layers of different resistivity for compensation of the horn effect. The selection of the adjusted tilt angle may be an iterative process using the geosignal responses. These processes can be conducted real time to determine the true formation resistivity. In addition, processes to determine the true formation resistivity may include features of different embodiments discussed herein.

20 In various embodiments, a machine-readable storage device can be structured having instructions stored thereon, which, when performed by a machine, cause the machine to perform operations that include using a processor and processing unit structured to process measurement values acquired from a measurement tool operating downhole to determine a true formation resistivity.

25 The measurement tool has arrangement of transmitter antennas and receiver antennas structured similar to or identical to any of the arrangements of transmitters and receivers discussed herein. The processor and processing unit can be coupled to measurement tool operating in the borehole. The operations performed from executing instructions can include, but are not limited to,

30 determining resistivity from measurement values, generating geosignals, determining adjustment tilt angles for the measurement tool, transforming the measurement values to new measurement values based on the adjusted tilt

angles, determining the presence of nearby boundaries operations, determining whether a resistivity is a true formation resistivity, and conducting procedures to determine an estimate of the true formation resistivity. The instructions can be executed to perform operations in a manner identical to or similar to processes
5 discussed in herein. The instructions can be executed in conjunction with a control unit to control the firing of selected transmitters and/or receivers and collection of signals at selected receivers and/or transmitters (in view of reciprocity) in a manner similar to or identical to operations associated with methods discussed herein. Further, a machine-readable storage device, herein, is
10 a physical device that stores data represented by physical structure within the device. Examples of machine-readable storage devices include, but are not limited to, read only memory (ROM), random access memory (RAM), magnetic disk storage device, optical storage device, flash memory, and other electronic, magnetic, and/or optical memory devices.

15 In various embodiments, a system comprises a measurement tool having one or more transmitters and one or more receivers in an antenna arrangement; a control unit operable to generate signals and collect signals in the antenna arrangement; and a processing unit to control and process measurement values from operating the measurement tool. The measurement tool, the control unit,
20 and the processing unit are configured to operate to perform features of methods similar to or identical to features associated with methods discussed herein. The one or more transmitters and the one or more receivers can be realized as transceivers. The control unit is operable to manage selective generation of signals from transceivers and to manage selective collection of received signals
25 at transceivers. The control unit and the processing unit can be structured as separate units or as an integrated unit. The control unit and the processing unit can be separate or integrated with the measurement tool.

Figure 24 depicts a block diagram of features of an example system operable to determine true formation resistivity. System 2400 includes a tool
30 2405 having an arrangement of transmitters 2410-1 and receivers 2410-2 operable in a borehole. The arrangements of the transmitters 2410-1 and the receivers 2410-2 of the tool 2405 can be realized similar to or identical to

arrangements discussed herein. The system 2400 can also include a controller 2415, a memory 2442, an electronic apparatus 2443, and a communications unit 2445. The controller 2415 and the memory 2442 can be arranged to operate the tool 2405 to acquire measurement data as the tool 2405 is operated and to assign
5 the acquired data to a number of bins, each correlated to an azimuthal angle in a rotation of the tool 2405. The controller 2415 and the memory 2442 can be realized to control activation of selected ones of the transmitter antennas 2410-1 and data acquisition by selected one of the receiver antennas 2410-2 in the tool 2405 and to manage processing schemes to determine a true formation resistivity
10 in accordance with measurement procedures and signal processing as described herein. Processing unit 2420 can be structured to perform the operations to manage processing schemes to determine a true formation resistivity in accordance with measurement procedures and signal processing in a manner similar to or identical to embodiments described herein.

15 Electronic apparatus 2443 can be used in conjunction with the controller 2415 to perform tasks associated with taking measurements downhole with the transmitters 2410-1 and the receivers 2410-2 of the tool 2405. Communications unit 2445 can include downhole communications in a drilling operation. Such downhole communications can include a telemetry system.

20 The system 2400 can also include a bus 2447, where the bus 2447 provides electrical conductivity among the components of the system 2400. The bus 2447 can include an address bus, a data bus, and a control bus, each independently configured. The bus 2447 can also use common conductive lines for providing one or more of address, data, or control, the use of which can be
25 regulated by the controller 2441. The bus 2447 can be configured such that the components of the system 2400 are distributed. Such distribution can be arranged between downhole components such as the transmitters 2410-1 and the receivers 2410-2 of the tool 2405 and components that can be disposed on the surface of a well. Alternatively, the components can be co-located such as on
30 one or more collars of a drill string or on a wireline structure.

In various embodiments, peripheral devices 2446 can include displays, additional storage memory, and/or other control devices that may operate in

conjunction with the controller 2441 and/or the memory 2442. In an embodiment, the controller 2415 can be realized as one or more processors. The peripheral devices 2446 can be arranged with a display with instructions stored in the memory 2442 to implement a user interface to manage the operation of the tool 2405 and/or components distributed within the system 2400. Such a user interface can be operated in conjunction with the communications unit 2445 and the bus 2447. Various components of the system 2400 can be integrated with the tool 2405 such that processing identical to or similar to the processing schemes discussed with respect to various embodiments herein can be performed downhole in the vicinity of the measurement or at the surface.

Figure 25 depicts an embodiment of a system 2500 at a drilling site, where the system 2500 includes an apparatus operable to determine true formation resistivity. The system 2500 can include a tool 2505-1, 2505-2, or both 2505-1 and 2505-2 having an arrangement of transmitter antennas and receiver antennas operable to make measurements that can be used for a number of drilling tasks including, but not limited to, determining resistivity of a formation. The tools 2505-1 and 2505-2 can be structured identical to or similar to a tool architecture or combinations of tool architectures discussed herein, including control units and processing units operable to perform processing schemes in a manner identical to or similar to processing techniques discussed herein. The tools 2505-1, 2505-2, or both 2505-1 and 2505-2 can be distributed among the components of system 2500. The tools 2505-1 and 2505-2 can be realized in a similar or identical manner to arrangements of control units, transmitters, receivers, and processing units discussed herein. The tools 2505-1 and 2505-2 can be structured, fabricated, and calibrated in accordance with various embodiments as taught herein.

The system 2500 can include a drilling rig 2502 located at a surface 2504 of a well 2506 and a string of drill pipes, that is, drill string 2529, connected together so as to form a drilling string that is lowered through a rotary table 2507 into a wellbore or borehole 2512-1. The drilling rig 2502 can provide support for the drill string 2529. The drill string 2529 can operate to penetrate rotary table 2507 for drilling the borehole 2512-1 through subsurface formations 2514.

The drill string 2529 can include a drill pipe 2518 and a bottom hole assembly 2520 located at the lower portion of the drill pipe 2518.

The bottom hole assembly 2520 can include a drill collar 2516 and a drill bit 2526. The drill bit 2526 can operate to create the borehole 2512-1 by
5 penetrating the surface 2504 and the subsurface formations 2514. The bottom hole assembly 2520 can include the tool 2505-1 attached to the drill collar 2516 to conduct measurements to determine formation parameters. The tool 2505-1 can be structured for an implementation as a MWD system such as a LWD system. The housing containing the tool 2505-1 can include electronics to
10 initiate measurements from selected transmitter antennas and to collect measurement signals from selected receiver antennas. Such electronics can include a processing unit to provide analysis of formation parameters over a standard communication mechanism for operating in a well. The analysis may include an analysis of an estimate of the true formation resistivity for each
15 formation layer investigated. Alternatively, electronics can include a communications interface to provide measurement signals collected by the tool 2505-1 to the surface over a standard communication mechanism for operating in a well, where these measurements signals can be analyzed at a processing unit at the surface to provide analysis of formation parameters, including an estimate
20 of the true formation resistivity for each formation layer investigated.

During drilling operations, the drill string 2529 can be rotated by the rotary table 2507. In addition to, or alternatively, the bottom hole assembly 2520 can also be rotated by a motor (e.g., a mud motor) that is located downhole. The drill collars 2516 can be used to add weight to the drill bit 2526. The drill
25 collars 2516 also can stiffen the bottom hole assembly 2520 to allow the bottom hole assembly 2520 to transfer the added weight to the drill bit 2526, and in turn, assist the drill bit 2526 in penetrating the surface 2504 and the subsurface formations 2514.

During drilling operations, a mud pump 2532 can pump drilling fluid
30 (sometimes known by those of skill in the art as “drilling mud”) from a mud pit 2534 through a hose 2536 into the drill pipe 2518 and down to the drill bit 2526. The drilling fluid can flow out from the drill bit 2526 and be returned to the

surface 2504 through an annular area 2540 between the drill pipe 2518 and the sides of the borehole 2512-1. The drilling fluid may then be returned to the mud pit 2534, where such fluid is filtered. In some embodiments, the drilling fluid can be used to cool the drill bit 2526, as well as to provide lubrication for the drill bit 2526 during drilling operations. Additionally, the drilling fluid may be used to remove subsurface formation cuttings created by operating the drill bit 2526.

In various embodiments, the tool 2505-2 may be included in a tool body 2570 coupled to a logging cable 2574 such as, for example, for wireline applications. The tool body 2570 containing the tool 2505-2 can include electronics to initiate measurements from selected transmitter antennas and to collect measurement signals from selected receiver antennas. Such electronics can include a processing unit to provide analysis of formation parameters over a standard communication mechanism for operating in a well. The analysis may include an analysis of an estimate of the true formation resistivity for each formation layer investigated. Alternatively, electronics can include a communications interface to provide measurement signals collected by the tool 2505-2 to the surface over a standard communication mechanism for operating in a well, where these measurements signals can be analyzed at a processing unit at the surface to provide analysis of formation parameters, including an estimate of the true formation resistivity for each formation layer investigated. The logging cable 2574 may be realized as a wireline (multiple power and communication lines), a mono-cable (a single conductor), and/or a slick-line (no conductors for power or communications), or other appropriate structure for use in the borehole 2512. Though Figure 25 depicts both an arrangement for wireline applications and an arrangement for LWD applications, the system 2500 may be also realized for one of the two applications.

Although specific embodiments have been illustrated and described herein, it will be appreciated by those of ordinary skill in the art that any arrangement that is calculated to achieve the same purpose may be substituted for the specific embodiments shown. Various embodiments use permutations and/or combinations of embodiments described herein. It is to be understood

WO 2014/120150

PCT/US2013/023826

that the above description is intended to be illustrative, and not restrictive, and that the phraseology or terminology employed herein is for the purpose of description. Combinations of the above embodiments and other embodiments will be apparent to those of skill in the art upon studying the above description.

5

CLAIMS

What is claimed is:

1. A method for reducing a horn effect to more accurately determine a true formation resistivity using an electromagnetic tool, the method comprising:

lowering the electromagnetic tool into a wellbore, wherein the electromagnetic tool comprises

a transmitter attached to the electromagnetic tool, wherein the

transmitter comprises a transmitter antenna,

a first receiver attached to the electromagnetic tool, wherein the first

receiver comprises a receiver antenna at a first tilt angle with

respect to a longitudinal axis of the electromagnetic tool, and

wherein the first receiver and the transmitter are axially

separated;

generating a signal with the transmitter;

measuring voltage values from the first receiver based on a measurement by the first receiver of the signal, wherein measuring voltage values comprises making measurements during a rotation of the electromagnetic tool, the rotation of the electromagnetic tool partitioned into a number of bins, in which completion of the number of bins is one complete rotation of the electromagnetic tool, wherein the number of bins is greater than one;

determining virtual voltage values at a second tilt angle based on the voltage values, the number of bins, a first ratio, and a second ratio, wherein the first ratio is based on the first tilt angle and the second tilt angle, and wherein the second ratio is based on the number of bins and a difference between the first tilt angle and the second tilt angle; and

determining an estimate of the true formation resistivity based on the virtual voltage values.

2. The method of claim 1, wherein determining virtual voltage values at the second tilt angle comprises determining $V_{R_{ind}}^{T_{ind}'}(i)$ according to

$$V_{R_{ind}}^{T_{ind}'}(i) = V_{R_{ind}}^{T_{ind}}(i) \times \frac{\sin \theta_{r2}}{\sin \theta_{r1}} + \frac{2}{N} \sum_{i=1}^N V_{R_{ind}}^{T_{ind}}(i) \times \frac{\sin(\theta_{r1} - \theta_{r2})}{\sin(2\theta_{r1})}, \quad i = 1, 2, \dots, N$$

where T_{ind} indicates an index of the transmitter and R_{ind} indicates an index of the first receiver, $V_{R_{ind}}^{T_{ind}}(i)$ is the signal measured at the first receiver, in response to a signal being transmitted from the transmitter having the index T_{ind} , in bin i , wherein i is an index value corresponding to one of the number of bins, θ_{r1} is the first tilt angle, and $V_{R_{ind}}^{T_{ind}}(i)$ is one of the virtual voltage values at the second tilt angle θ_{r2} .

3. The method of claim 1, wherein the transmitter is non-tilted.
4. The method of claim 1, wherein the transmitter is perpendicular to the first receiver.
5. The method of claim 1, wherein determining virtual voltage values at the second tilt angle comprises determining coupling components, wherein each of the coupling components is one of a set of tensor components of the measurement by the first receiver of the signal in an orthogonal basis shared by the coupling components.
6. The method of claim 1, wherein the electromagnetic tool further comprises a second receiver, and wherein the transmitter is equidistant from the first receiver and the second receiver.
7. The method of claim 1, wherein the method includes using the estimate of the true formation resistivity as an initial guess in a one-dimensional or multi-dimensional inversion procedure.
8. The method of claim 1, wherein
 - determining an average phase resistivity measurement based on the voltage values;
 - determining whether the average phase resistivity measurement corresponds to the true formation resistivity;
 - based on the average phase resistivity measurement not corresponding to

the true formation resistivity, determining a reevaluated average phase resistivity based on virtual voltage values, wherein the virtual voltage values are determined at a second tilt angle based on the voltage values, the number of bins, a first ratio, and a second ratio, wherein the first ratio is based on the first tilt angle, and wherein the second ratio is based on the number of bins and a difference between the first tilt angle and the second tilt angle; and determining the true formation resistivity based on the reevaluated average phase resistivity.

9. The method of claim 8, wherein determining whether the average phase resistivity measurement corresponds to the true formation resistivity comprises determining whether the electromagnetic tool is near a boundary when measuring the voltage values.

10. The method of claim 9, further comprising:
determining geosignals based on the voltage values; and
determining whether the electromagnetic tool is near the boundary when measuring the voltage values.

11. The method of claim 8, wherein determining the reevaluated average phase resistivity comprises determining second virtual measured values based on the voltage values, the first tilt angle, and a third tilt angle.

12. The method of claim 8, wherein determining virtual voltage values is further based on coupling components, wherein each of the coupling components is one of a set of tensor components of the measurement by the first receiver of the signal in an orthogonal basis shared by the coupling components.

13. A method for reducing a horn effect to more accurately determine a true formation resistivity using an electromagnetic tool, the method comprising:
lowering the electromagnetic tool into a wellbore, wherein the electromagnetic tool comprises
a transmitter attached to the electromagnetic tool, wherein the

transmitter comprises a transmitter antenna,
a first receiver attached to the electromagnetic tool, wherein the first receiver comprises a receiver antenna at a first tilt angle with respect to a longitudinal axis of the electromagnetic tool, and wherein the first receiver and the transmitter are axially separated;

generating a signal with the transmitter;

measuring voltage values from the first receiver based on a measurement by the first receiver of the signal, wherein measuring voltage values comprises making measurements during a rotation of the electromagnetic tool, the rotation of the electromagnetic tool partitioned into a number of bins, in which completion of the number of bins is one complete rotation of the electromagnetic tool, wherein the number of bins is greater than one;

determining an average phase resistivity measurement based on the voltage values;

determining whether the average phase resistivity measurement corresponds to the true formation resistivity;

based on the average phase resistivity measurement not corresponding to the true formation resistivity, physically adjusting at least one of a tilt angle of the transmitter or the first tilt angle;

measuring new voltage values from the first receiver;

determining a reevaluated average phase resistivity based on the new voltage values; and

determining the true formation resistivity based on the reevaluated average phase resistivity.

14. A method for reducing a horn effect to more accurately determine a true formation resistivity using an electromagnetic tool, the method comprising:

lowering the electromagnetic tool into a wellbore, wherein the electromagnetic tool comprises

a transmitter attached to the electromagnetic tool, wherein the transmitter comprises a transmitter antenna,

a first receiver attached to the electromagnetic tool, wherein the first receiver comprises a receiver antenna at a first tilt angle with

respect to a longitudinal axis of the electromagnetic tool, and wherein the first receiver and the transmitter are axially separated;

generating a signal with the transmitter;

measuring voltage values from the first receiver based on a measurement by the first receiver of the signal, wherein measuring voltage values from the first receiver comprises making measurements during a rotation of the electromagnetic tool, the rotation of the electromagnetic tool partitioned into a number of bins, in which completion of the number of bins is one complete rotation of the electromagnetic tool, wherein the number of bins is greater than one;

determining an average phase resistivity from the voltage values;

determining whether the electromagnetic tool is near a boundary based on geosignal responses;

based on the electromagnetic tool being near the boundary, physically adjusting at least one of a tilt angle of the transmitter or the first tilt angle;

determining new voltage values from the first receiver;

determining a new average phase resistivity measurement based on the new voltage values; and

determining the true formation resistivity based on the new average phase resistivity measurement.

15. The method of claim 14, further comprising a second receiver, wherein the second receiver has the first tilt angle, and wherein the transmitter is non-tilted.

16. The method of claim 14, further comprising a second receiver, wherein the second receiver has the first tilt angle, and wherein the transmitter is perpendicular to the first receiver and the second receiver.

17. The method of claim 1, wherein:

determining average phase resistivity measurements based on the voltage values, wherein each of the voltage values are based on one of a plurality of antenna pairs, wherein the each of the plurality of antenna pairs comprises the

transmitter and one of the first receiver or a second receiver in the electromagnetic tool;

determining whether the average phase resistivity measurements correspond to the true formation resistivity based on a comparison of the average phase resistivity measurements;

based on the average phase resistivity measurements not estimating the true formation resistivity, using geosignal responses to indicate whether the electromagnetic tool is near a boundary;

based on the geosignal responses indicating that the electromagnetic tool is near the boundary, determining virtual voltage values at a second tilt angle using one or more processors based on the voltage values, the number of bins, a first ratio, and a second ratio, wherein the first ratio is based on the first tilt angle and the second tilt angle, and wherein the second ratio is based on the number of bins and a difference between the first tilt angle and the second tilt angle; and

determining an estimate of the true formation resistivity based on the virtual voltage values using the one or more processors.

18. The method of claim 17, wherein the comparison of the average phase resistivity measurements comprises determining if magnitudes of respective differences between the average phase resistivity measurements are greater than a threshold.

19. The method of claim 17, further comprising using the estimate of the true formation resistivity as an initial guess in a one-dimensional or multi-dimensional inversion procedure.

20. A computer readable storage medium having recorded thereon instructions executable by a processor to:

lower an electromagnetic tool into a wellbore, wherein the electromagnetic tool comprises

a transmitter attached to the electromagnetic tool, wherein the transmitter comprises a transmitter antenna,

a first receiver attached to the electromagnetic tool, wherein the first receiver comprises a receiver antenna at a first tilt angle with

respect to a longitudinal axis of the electromagnetic tool, and wherein the first receiver and the transmitter are axially separated;

generate a signal with the transmitter;

measure voltage values from the first receiver based on a measurement by the first receiver of the signal, wherein measuring voltage values comprises making measurements during a rotation of the electromagnetic tool, the rotation of the electromagnetic tool partitioned into a number of bins, in which completion of the number of bins is one complete rotation of the electromagnetic tool, wherein the number of bins is greater than one;

determine virtual voltage values at a second tilt angle using one or more processors based on the voltage values, the number of bins, a first ratio, and a second ratio, wherein the first ratio is based on the first tilt angle and the second tilt angle, and wherein the second ratio is based on the number of bins and a difference between the first tilt angle and the second tilt angle; and

determine an estimate of a true formation resistivity based on the virtual voltage values using the one or more processors.

21. A system to determine a true formation resistivity using an electromagnetic tool, the system comprising:

the electromagnetic tool, wherein the electromagnetic tool comprises a transmitter attached to the electromagnetic tool, wherein the transmitter comprises a transmitter antenna, and

a first receiver attached to the electromagnetic tool, wherein the first receiver comprises a receiver antenna at a first tilt angle with respect to a longitudinal axis of the electromagnetic tool, and wherein the first receiver and the transmitter are axially separated;

one or more processors; and

a non-transitory machine-readable storage medium having program code executable by the one or more processors to:

generate a signal with the transmitter;

measure voltage values from the first receiver based on a measurement by the first receiver of the signal, wherein measuring voltage values comprises making measurements during a rotation of the electromagnetic

tool, the rotation of the electromagnetic tool partitioned into a number of bins, in which completion of the number of bins is one complete rotation of the electromagnetic tool, wherein the number of bins is greater than one;

determine virtual voltage values at a second tilt angle based on the voltage values, the number of bins, a first ratio, and a second ratio, wherein the first ratio is based on the first tilt angle and the second tilt angle, and wherein the second ratio is based on the number of bins and a difference between the first tilt angle and the second tilt angle; and

determine an estimate of the true formation resistivity based on the virtual voltage values.

22. The system of claim 21, wherein the program code executable by the one or more processors to determine virtual voltage values at the second tilt angle comprises program code to determine $V_{R_{ind}}^{T_{ind}}(i)$ according to

$$V_{R_{ind}}^{T_{ind}}(i) = V_{R_{ind}}^{T_{ind}}(i) \times \frac{\sin \theta_{r2}}{\sin \theta_{r1}} + \frac{2}{N} \sum_{i=1}^N V_{R_{ind}}^{T_{ind}}(i) \times \frac{\sin(\theta_{r1} - \theta_{r2})}{\sin(2\theta_{r1})}, \quad i = 1, 2, \dots, N$$

where T_{ind} indicates an index of the transmitter and R_{ind} indicates an index of the first receiver, $V_{R_{ind}}^{T_{ind}}(i)$ is the signal measured at the first receiver, in response to the signal being transmitted from the transmitter having the index T_{ind} , in bin i , wherein i is an index value corresponding to one of the number of bins, θ_{r1} is the first tilt angle, and $V_{R_{ind}}^{T_{ind}}(i)$ is one of the virtual voltage values at the second tilt angle θ_{r2} .

23. The system of claim 22, wherein the transmitter is non-tilted.

24. The system of claim 22, wherein the transmitter is perpendicular to the first receiver.

25. The system of claim 24, wherein the program code executable by the one or more processors generates new voltage values comprises program code to determine coupling components, wherein each of the coupling components is

one of a set of tensor components of the measurement by the first receiver of the signal in an orthogonal basis shared by the coupling components.

26. The system of claim 21, wherein the electromagnetic tool further comprises a second receiver, and wherein the transmitter is equidistant from the first receiver and the second receiver.

27. A system to determine a true formation resistivity using an electromagnetic tool, the system comprising:

- the electromagnetic tool, wherein the electromagnetic tool comprises a transmitter attached to the electromagnetic tool, wherein the transmitter comprises a transmitter antenna, and

- a first receiver attached to the electromagnetic tool, wherein the first receiver comprises a receiver antenna at a first tilt angle with respect to a longitudinal axis of the electromagnetic tool, and wherein the first receiver and the transmitter are axially separated;

- one or more processors; and

- a non-transitory machine-readable storage medium having program code executable by the one or more processors to:

- generate a signal with the transmitter

- measure voltage values from the first receiver based on a measurement by the first receiver of the signal, wherein measuring voltage values comprises making measurements during a rotation of the electromagnetic tool, the rotation of the electromagnetic tool partitioned into a number of bins, in which completion of the number of bins is one complete rotation of the electromagnetic tool, wherein the number of bins is greater than one;

- determine an average phase resistivity measurement based on the voltage values;

- determine whether the average phase resistivity measurement corresponds to the true formation resistivity; and

- based on the average phase resistivity measurement not corresponding to the true formation resistivity, determine a reevaluated average phase resistivity based on virtual voltage values using the one or

more processors, wherein the virtual voltage values are determined at a second tilt angle using the one or more processors based on the voltage values, the number of bins, a first ratio, and a second ratio, wherein the first ratio is based on the first tilt angle and the second tilt angle, and wherein the second ratio is based on the number of bins and a difference between the first tilt angle and the second tilt angle; and

determine the true formation resistivity based on the reevaluated average phase resistivity.

28. The system of claim 27, wherein the program code executable by the one or more processors determines whether the average phase resistivity measurement corresponds to the true formation resistivity comprises program code to determine whether the electromagnetic tool is near a boundary when measuring the voltage values.

29. The system of claim 27, wherein the program code executable by the one or more processors determines second virtual voltage values based on the voltage values, the first tilt angle, and a third tilt angle, wherein the first receiver has the first tilt angle.

30. The system of claim 27, wherein the program code executable by the one or more processors determines the virtual voltage values is based on coupling components, wherein each of the coupling components is one of a set of tensor components of the measurement by the first receiver of the signal in an orthogonal basis shared by the coupling components.

31. A system to determine a true formation resistivity using an electromagnetic tool, the system comprising:
the electromagnetic tool, wherein the electromagnetic tool comprises a transmitter attached to the electromagnetic tool, wherein the transmitter comprises a transmitter antenna, and
a first receiver attached to the electromagnetic tool, wherein the first

receiver comprises a receiver antenna at a first tilt angle with respect to a longitudinal axis of the electromagnetic tool, and wherein the first receiver and the transmitter are axially separated;

one or more processors; and

a non-transitory machine-readable medium having program code executable by the one or more processors to :

generate a signal with the transmitter;

measure voltage values from the first receiver based on a measurement by the first receiver of the signal, wherein measuring voltage values comprises making measurements during a rotation of the electromagnetic tool, the rotation of the electromagnetic tool partitioned into a number of bins, in which completion of the number of bins is one complete rotation of the electromagnetic tool, wherein the number of bins is greater than one;

determine an average phase resistivity measurement based on the voltage values;

determine whether the average phase resistivity measurement corresponds to the true formation resistivity;

based on the average phase resistivity measurement not corresponding to the true formation resistivity, physically adjust at least one of a tilt angle of the transmitter and the first tilt angle;

measure new voltage values from the first receiver;

determine a reevaluated average phase resistivity based on the new voltage values; and

determine the true formation resistivity based on the reevaluated average phase resistivity.

32. A system to determine a true formation resistivity using an electromagnetic tool, the system comprising:

the electromagnetic tool, wherein the electromagnetic tool comprises

a transmitter attached to the electromagnetic tool, wherein the transmitter comprises a transmitter antenna, and

a first receiver attached to the electromagnetic tool, wherein the first receiver comprises a receiver antenna at a first tilt angle with respect to a

longitudinal axis of the electromagnetic tool, and wherein the first receiver and the transmitter are axially separated;

one or more processors; and

a machine-readable medium having program code executable by the one or more processors to:

generate a signal with the transmitter;

measure voltage values from the first receiver based on a measurement by the first receiver of the signal, wherein measuring voltage values comprises making measurements during a rotation of the electromagnetic tool, the rotation of the electromagnetic tool partitioned into a number of bins, in which completion of the number of bins is one complete rotation of the electromagnetic tool, wherein the number of bins is greater than one;

determine an average phase resistivity from the voltage values;

determine whether the electromagnetic tool is near a boundary based on geosignal responses;

based on the electromagnetic tool being near the boundary, physically adjust at least one of a tilt angle of the transmitter or the first tilt angle, and

determine a new average phase resistivity based on new voltage values from the first receiver; and

determine the true formation resistivity based on the new average phase resistivity.

33. The system of claim 32, further comprising a second receiver, wherein the second receiver has the first tilt angle, and wherein the transmitter is non-tilted.

34. The system of claim 32, further comprising a second receiver, wherein the second receiver has the first tilt angle, and wherein the transmitter is perpendicular to the first receiver and the second receiver.

35. A system to determine a true formation resistivity using an

electromagnetic tool, the system comprising:

the electromagnetic tool, wherein the electromagnetic tool comprises a transmitter attached to the electromagnetic tool, wherein the transmitter comprises a transmitter antenna,

a first receiver attached to the electromagnetic tool, wherein the first receiver comprises a first receiver antenna at a first tilt angle with respect to a longitudinal axis of the electromagnetic tool, and wherein the first receiver and the transmitter are axially separated, and

a second receiver attached to the electromagnetic tool, wherein the second receiver comprises a second receiver antenna at an alternate tilt angle with respect to the longitudinal axis of the electromagnetic tool, and wherein the second receiver is axially separated from the transmitter;

one or more processors; and

a non-transitory machine-readable storage medium having program code executable by the one or more processors to:

generate a signal using the transmitter;

measure voltage values from the first receiver based on a measurement by the first receiver of the signal, wherein measuring voltage values comprises making measurements during a rotation of the electromagnetic tool, the rotation of the electromagnetic tool partitioned into a number of bins, in which completion of the number of bins is one complete rotation of the electromagnetic tool, wherein the number of bins is greater than one;

determine average phase resistivity measurements based on the voltage values, wherein each of the voltage values are based on one of a plurality of antenna pairs, wherein the each of the plurality of antenna pairs comprises the transmitter and one of the first receiver or a second receiver in the electromagnetic tool;

determine whether the average phase resistivity measurements correspond to the true formation resistivity based on a comparison of the average phase resistivity measurements; and

based on the average phase resistivity measurements not estimating the true formation resistivity, use geosignal responses to indicate whether the electromagnetic tool is near a boundary;

based on the geosignal responses indicating that the electromagnetic tool is near the boundary, determine virtual voltage values at a second tilt angle using the one or more processors based on the voltage values, the number of bins, a first ratio, and a second ratio, wherein the first ratio is based on the second tilt angle and either the first tilt angle or the alternate tilt angle, and wherein the second ratio is based on the number of bins and a difference between the second tilt angle and either the first tilt angle or the alternate tilt angle; and

determining an estimate of the true formation resistivity based on the virtual voltage values.

36. The system of claim 35, wherein the comparison of the average phase resistivity measurements comprises determining if magnitudes of respective differences between the average phase resistivity measurements are greater than a threshold.

37. The system of claim 35, wherein the program code executable by the one or more processors to use the estimate of the true formation resistivity as an initial guess in a one-dimensional or multi-dimensional inversion procedure.

38. The computer readable storage medium of claim 20, wherein the program code to determine virtual voltage values at the second tilt angle comprises program code to determine $V_{R_{ind}}^{T_{ind}}(i)$ according to

$$V_{R_{ind}}^{T_{ind}}(i) = V_{R_{ind}}^{T_{ind}}(i) \times \frac{\sin \theta_{r2}}{\sin \theta_{r1}} + \frac{2}{N} \sum_{i=1}^N V_{R_{ind}}^{T_{ind}}(i) \times \frac{\sin(\theta_{r1} - \theta_{r2})}{\sin(2\theta_{r1})}, \quad i = 1, 2, \dots, N$$

where T_{ind} indicates an index of the transmitter and R_{ind} indicates an index of the first receiver, $V_{R_{ind}}^{T_{ind}}(i)$ is the signal measured at receiver R_{ind} , in response to the signal being transmitted from the transmitter having the index T_{ind} , in bin i , wherein i is an index value corresponding to one of the number of bins, θ_{r1} is the first tilt angle, and $V_{R_{ind}}^{T_{ind}}(i)$ is one of the virtual voltage values at the second tilt angle θ_{r2} .

39. The computer readable storage medium of claim 20, wherein the transmitter is non-tilted.
40. The computer readable storage medium of claim 20, wherein the transmitter is perpendicular to the first receiver.
41. The computer readable storage medium of claim 40, wherein the program code to determine new voltage values comprises program code to determining coupling components, wherein each of the coupling components is one of a set of tensor components of the measurement by the first receiver of the signal in an orthogonal basis shared by the coupling components.
42. The computer readable storage medium of claim 20, wherein the electromagnetic tool further comprises a second receiver, and wherein the transmitter is equidistant from the first receiver and the second receiver.
43. A computer readable storage medium having recorded thereon instructions executable by a processor to:
- lower an electromagnetic tool into a wellbore, wherein the electromagnetic tool comprises
 - a transmitter attached to the electromagnetic tool, wherein the transmitter comprises a transmitter antenna,
 - a first receiver attached to the electromagnetic tool, wherein the first receiver comprises a receiver antenna at a first tilt angle with respect to a longitudinal axis of the electromagnetic tool, and wherein the first receiver and the transmitter are axially separated;
 - generate a signal with the transmitter;
 - measure voltage values from the first receiver based on a measurement by the first receiver of the signal, wherein measuring voltage values comprises making measurements during a rotation of the electromagnetic tool, the rotation of the electromagnetic tool partitioned into a number of bins, in which completion of the number of bins is one complete rotation of the electromagnetic

tool, wherein the number of bins is greater than one;

determine an average phase resistivity measurement based on from the voltage values;

determine whether the average phase resistivity measurement corresponds to a true formation resistivity; and

based on the average phase resistivity measurement not corresponding to the true formation resistivity, determine a reevaluated average phase resistivity based on virtual voltage values, wherein the virtual voltage values are determined at a second tilt angle based on the voltage values, the number of bins, a first ratio, and a second ratio, wherein the first ratio is based on the first tilt angle, and wherein the second ratio is based on the number of bins and a difference between the first tilt angle and the second tilt angle; and

determine the true formation resistivity based on the reevaluated average phase resistivity.

44. The computer readable storage medium of claim 43, wherein the program code to determine whether the average phase resistivity measurement corresponds to the true formation resistivity comprises program code to determine whether the electromagnetic tool is near a boundary when measuring the voltage values.

45. The computer readable storage medium of claim 43, wherein the program code to determine the reevaluated average phase resistivity comprises program code to determine second virtual voltage values based on the voltage values, first tilt angle, and a third tilt angle.

46. The computer readable storage medium of claim 43, wherein the program code to determine the virtual voltage values comprises program code to determine virtual voltage values based on coupling components, wherein each of the coupling components is one of a set of tensor components of the measurement by the first receiver of the signal in an orthogonal basis shared by the coupling components.

47. The computer readable storage medium of claim 43, further comprising

program code to use the reevaluated average phase resistivity as an initial guess in a one-dimensional or multi-dimensional inversion procedure.

48. A computer readable storage medium having recorded thereon instructions executable by a processor to:

lower the electromagnetic tool into a wellbore, wherein the electromagnetic tool comprises

a transmitter attached to the electromagnetic tool, wherein the

transmitter comprises a transmitter antenna,

a first receiver attached to the electromagnetic tool, wherein the first

receiver comprises a receiver antenna at a first tilt angle with

respect to a longitudinal axis of the electromagnetic tool, and

wherein the first receiver and the transmitter are axially

separated;

generate a signal with the transmitter;

measure voltage values from the first receiver based on a measurement

by the first receiver of the signal, wherein measuring voltage values comprises

making measurements during a rotation of the electromagnetic tool, the rotation

of the electromagnetic tool partitioned into a number of bins, in which

completion of the number of bins is one complete rotation of the electromagnetic

tool, wherein the number of bins is greater than one;

determine an average phase resistivity measurement based on the voltage values;

determine whether the average phase resistivity measurement corresponds to a true formation resistivity;

based on the average phase resistivity measurement not corresponding to the true formation resistivity, physically adjust at least one of a tilt angle of the transmitter or the first tilt angle;

measure new voltage values from the first receiver;

determine a reevaluated average phase resistivity based on the new voltage values; and

determine the true formation resistivity based on the reevaluated average phase resistivity.

49. A computer readable storage medium having recorded thereon instructions executable by a processor to:

lower an electromagnetic tool into a wellbore, wherein the electromagnetic tool comprises

a transmitter attached to the electromagnetic tool, wherein the transmitter comprises a transmitter antenna,

a first receiver attached to the electromagnetic tool, wherein the first receiver comprises a receiver antenna at a first tilt angle with respect to a longitudinal axis of the electromagnetic tool, and wherein the first receiver and the transmitter are axially separated;

generate a signal using the transmitter, wherein one or more processors is coupled to the electromagnetic tool;

measure voltage values from the first receiver based on a measurement by the first receiver of the signal, wherein measuring voltage values comprises making measurements during a rotation of the electromagnetic tool, the rotation of the electromagnetic tool partitioned into a number of bins, in which completion of the number of bins is one complete rotation of the electromagnetic tool, wherein the number of bins is greater than one;

determine an average phase resistivity from the voltage values;

determine whether the electromagnetic tool is near a boundary based on geosignal responses;

based on the electromagnetic tool being near the boundary, physically adjust at least one of a tilt angle of the transmitter or the first tilt angle;

determine new voltage values from the first receiver;

determine a new average phase resistivity measurement based on the new voltage values; and

determine an estimate of a true formation resistivity based on the new average phase resistivity measurement.

50. The computer readable storage medium of claim 49, wherein the electromagnetic tool further comprises a second receiver, wherein the second receiver has the first tilt angle, and wherein the transmitter is non-tilted.

51. The computer readable storage medium of claim 49, wherein the transmitter is perpendicular to the first receiver.

52. A computer readable storage medium having recorded thereon instructions executable by a processor to:

lower an electromagnetic tool into a wellbore, wherein the electromagnetic tool comprises

a transmitter attached to the electromagnetic tool, wherein the

transmitter comprises a transmitter antenna,

a first receiver attached to the electromagnetic tool, wherein the first

receiver comprises a receiver antenna at a first tilt angle with

respect to a longitudinal axis of the electromagnetic tool, and

wherein the first receiver and the transmitter are axially

separated;

generate a signal with the transmitter;

measure voltage values from the first receiver based on a measurement

by the first receiver of the signal, wherein measuring voltage values comprises

making measurements during a rotation of the electromagnetic tool, the rotation

of the electromagnetic tool partitioned into a number of bins, in which

completion of the number of bins is one complete rotation of the electromagnetic

tool, wherein the number of bins is greater than one;

determine average phase resistivity measurements based on the voltage

values, wherein each of the voltage values are based on one of a plurality of

antenna pairs, wherein the each of the plurality of antenna pairs comprises the

transmitter and one of the first receiver or a second receiver in the

electromagnetic tool;

determine whether the average phase resistivity measurements

corresponds to a true formation resistivity based on a comparison of the average phase resistivity measurements;

based on the average phase resistivity measurements not estimating the

true formation resistivity, use geosignal responses to indicate whether the

electromagnetic tool is near a boundary;

based on the geosignal responses indicating that the electromagnetic tool is near the boundary, determine virtual voltage values at a second tilt angle using

one or more processors, based on the voltage values, the number of bins, a first ratio, and a second ratio, wherein the first ratio is based on the first tilt angle and the second tilt angle, and wherein the second ratio is based on the number of bins and a difference between the first tilt angle and the second tilt angle; and

determine an estimate of the true formation resistivity based on the virtual voltage values.

53. The computer readable storage medium of claim 52, wherein the comparison of the average phase resistivity measurements is determined by determining if magnitudes of respective differences between the average phase resistivity measurements are greater than a threshold.

54. The computer readable storage medium of claim 52, further comprising program code to use a value corresponding to the true formation resistivity as an initial guess in a one-dimensional or multi-dimensional inversion procedure such that an inverted geology formation is optimized.

55. The method of claim 8, wherein the electromagnetic tool further comprises a second receiver having a second receiver tilt angle, wherein the difference between the second receiver tilt angle and the first tilt angle is greater by at least 20 degrees.

56. The method of claim 17, wherein the second receiver has a second receiver tilt angle, wherein the difference between the second receiver tilt angle and the first tilt angle is greater by at least 20 degrees.

57. The system of claim 21, wherein the electromagnetic tool further comprises a second receiver having a second receiver tilt angle, wherein the difference between the second receiver tilt angle and the first tilt angle is greater by at least 20 degrees.

58. The system of claim 27, wherein the electromagnetic tool further

comprises a second receiver having a second receiver tilt angle, wherein the difference between the second receiver tilt angle and the first tilt angle is greater by at least 20 degrees.

59. The system of claim 35, wherein the second receiver has a second receiver tilt angle, wherein the difference between the second receiver tilt angle and the first tilt angle is greater by at least 20 degrees.

60. The computer readable storage medium of claim 43, wherein the electromagnetic tool further comprises a second receiver having a second receiver tilt angle, wherein the difference between the second receiver tilt angle and the first tilt angle is greater by at least 20 degrees.

61. The method of claim 1, further comprising geosteering a drill bit towards a drilling direction based on the virtual voltage values.

62. The method of claim 8, further comprising geosteering a drill bit towards a drilling direction based on the reevaluated average phase resistivity.

63. The method of claim 13, further comprising geosteering a drill bit towards a drilling direction based on the new voltage values.

64. The method of claim 14, further comprising geosteering a drill bit towards a drilling direction based on the new voltage values.

65. The method of claim 17, further comprising geosteering a drill bit towards a drilling direction based on the virtual voltage values.

66. The computer readable storage medium of claim 20, further comprising program code to geosteer a drill bit towards a drilling direction based on the virtual voltage values.

67. The system of claim 21, further comprising program code to geosteer a

drill bit towards a drilling direction based on the virtual voltage values.

68. The system of claim 27, further comprising program code executable by the one or more processors to geosteer a drill bit towards a drilling direction based on the reevaluated average phase resistivity.

69. The system of claim 31, further comprising program code executable by the one or more processors to geosteer a drill bit towards a drilling direction based on the new voltage values.

70. The system of claim 32, further comprising code executable by the one or more processors to geosteer a drill bit towards a drilling direction based on the new voltage values.

71. The system of claim 35, further comprising code executable by the one or more processors to geosteer a drill bit towards a drilling direction based on the virtual voltage values.

72. The computer readable storage medium of claim 43, further comprising code to geosteer a drill bit towards a drilling direction based on the virtual voltage values.

73. The computer readable storage medium of claim 48, further comprising code to geosteer a drill bit towards a drilling direction based on the new voltage values.

74. The computer readable storage medium of claim 49, further comprising code to geosteer a drill bit towards a drilling direction based on the new voltage values.

75. The computer readable storage medium of claim 52, further comprising code to geosteer a drill bit towards a drilling direction based on the virtual voltage values.

1/18

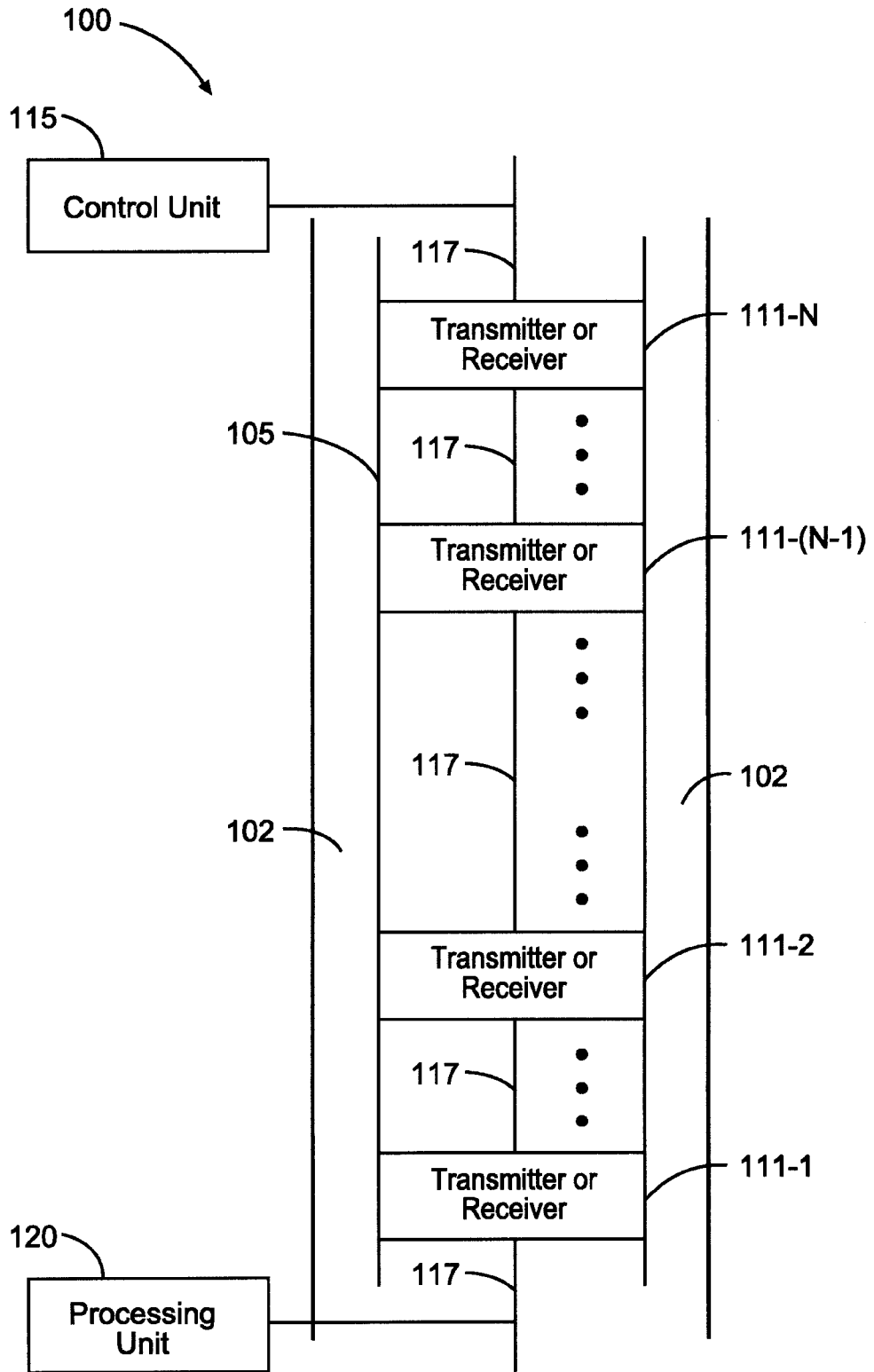

Fig. 1

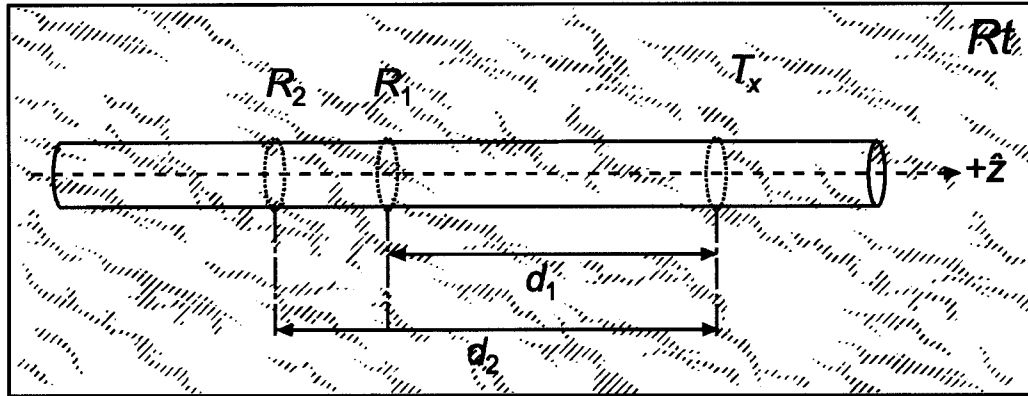

Fig. 2

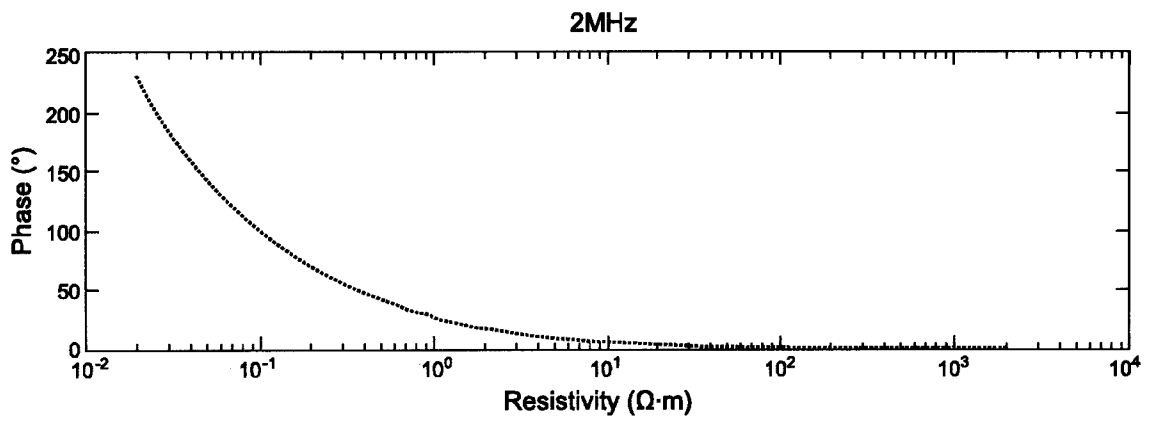

Fig. 3A

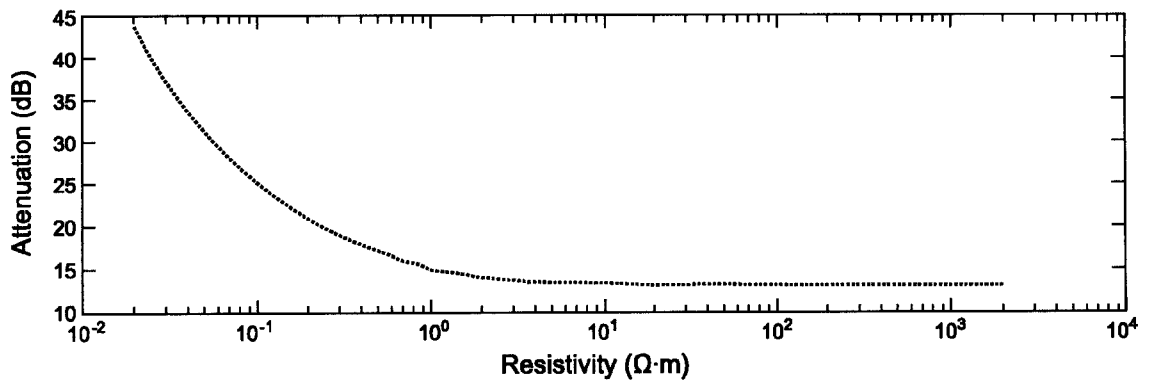

Fig. 3B

3/18

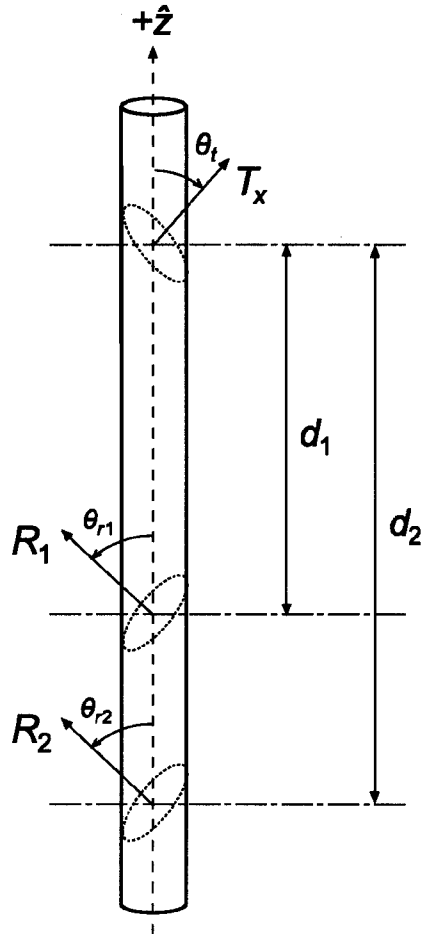

Fig. 4

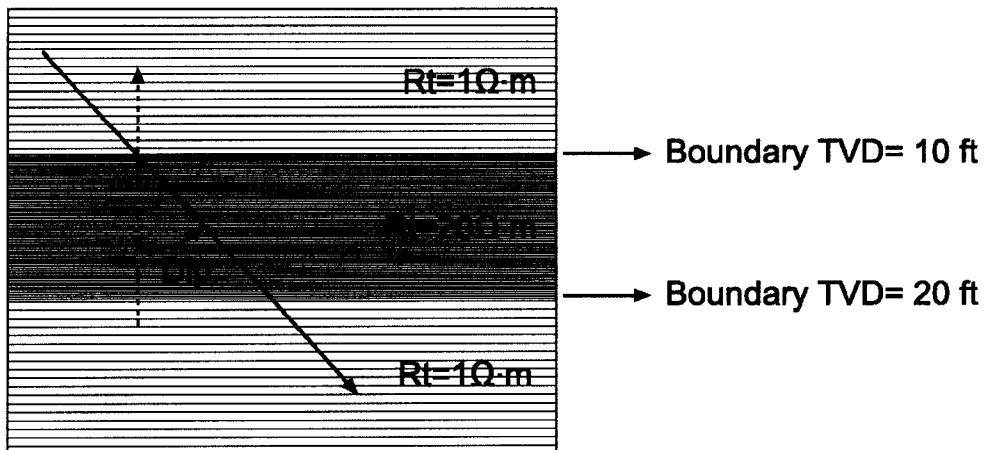

Fig. 5

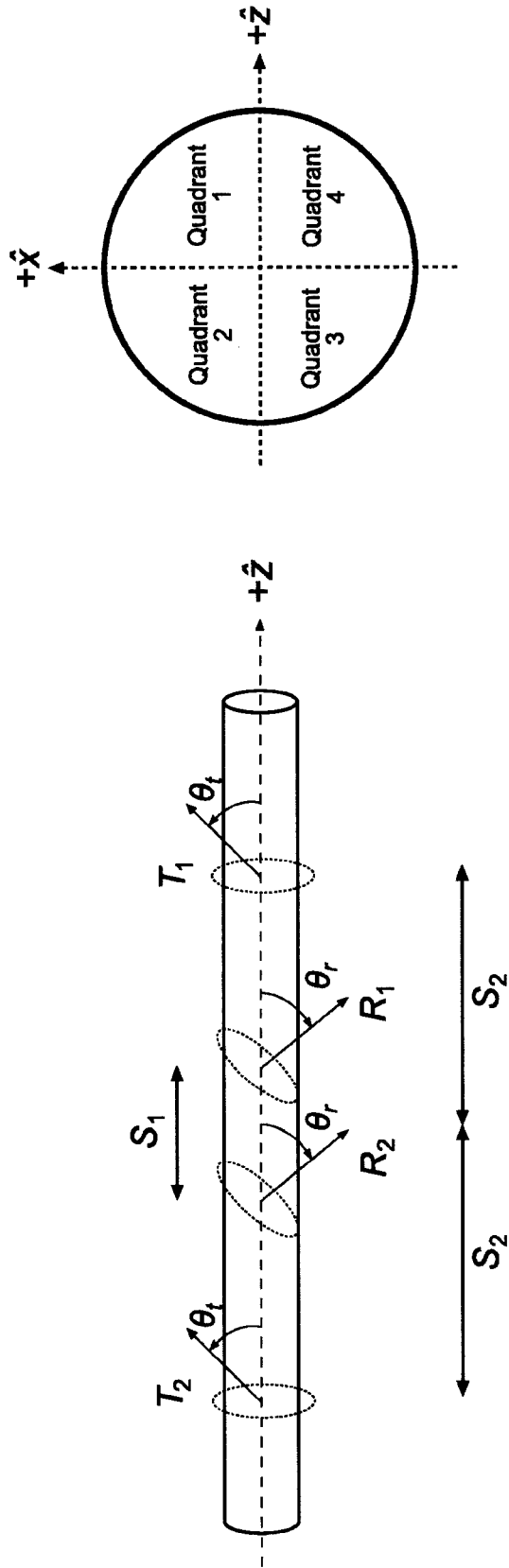

Fig. 6

5/18

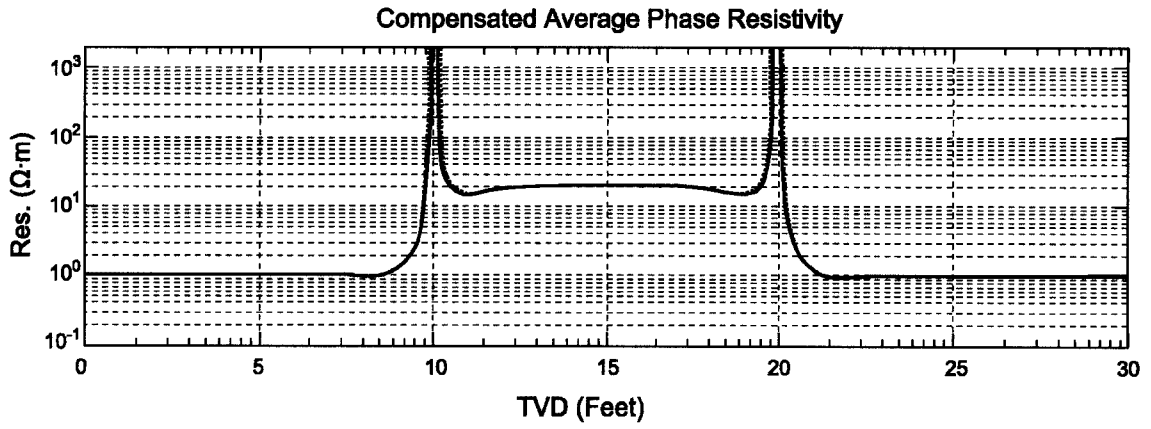

Fig. 7A

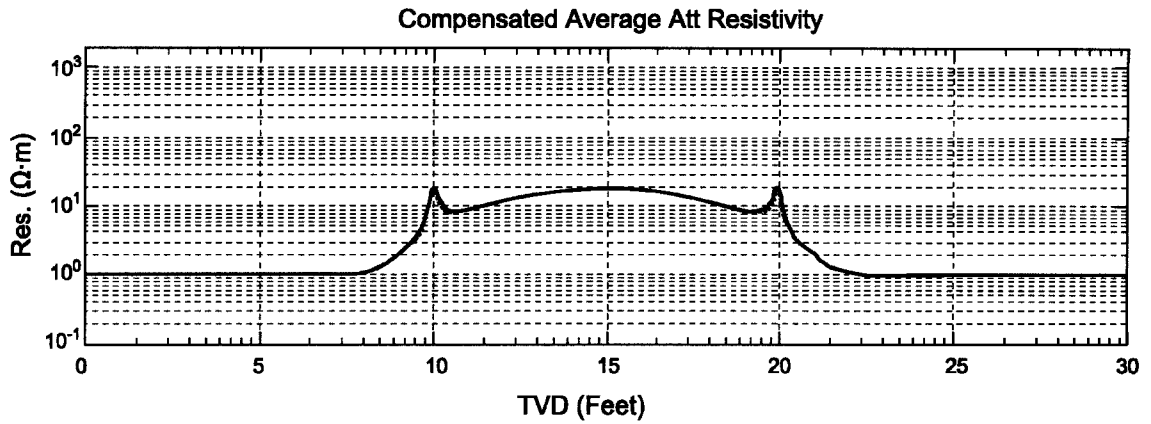

Fig. 7B

6/18

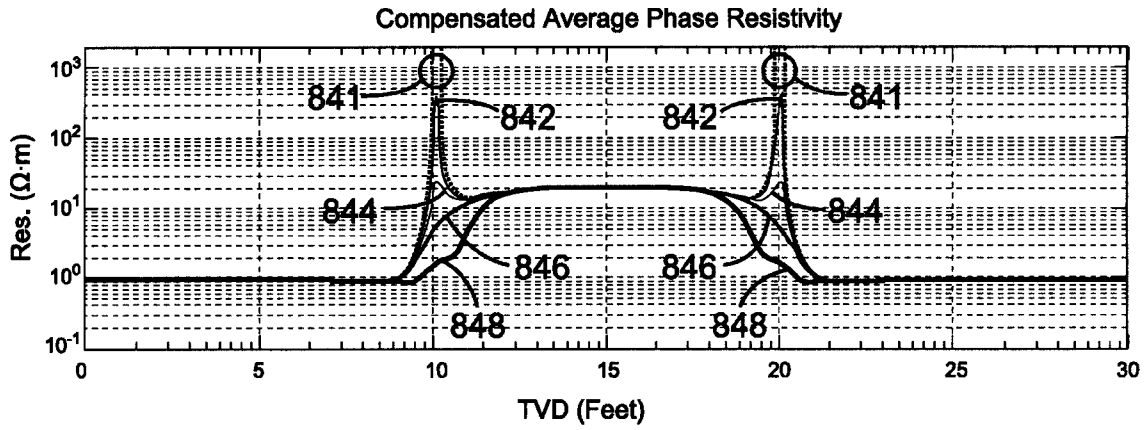

Fig. 8A

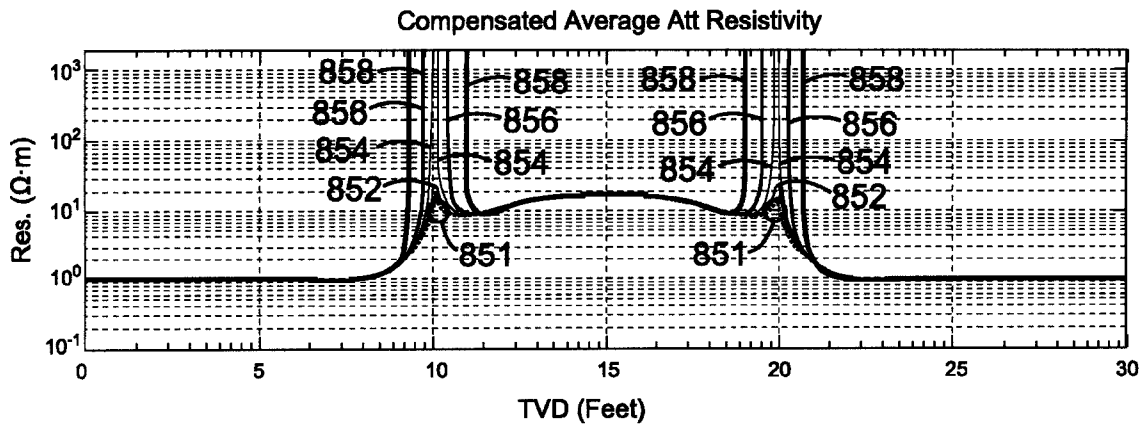

Fig. 8B

7/18

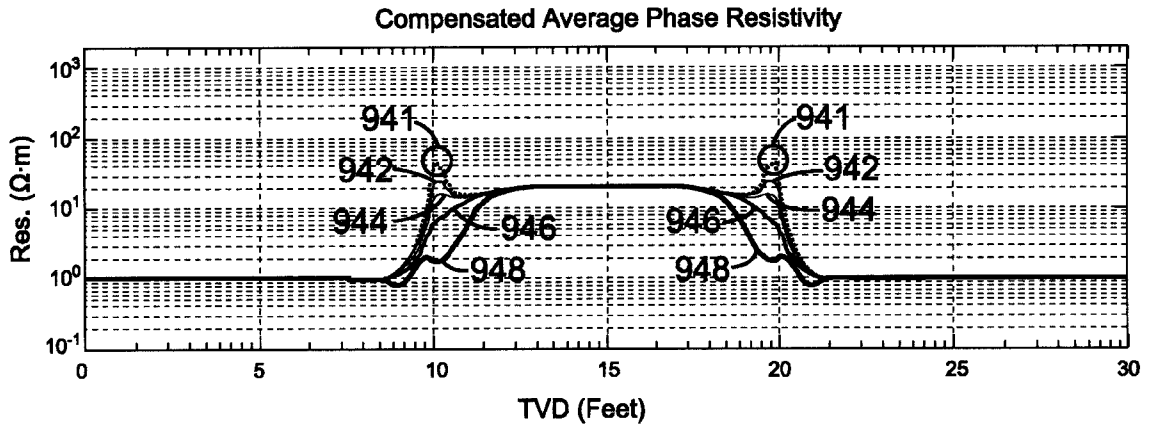

Fig. 9A

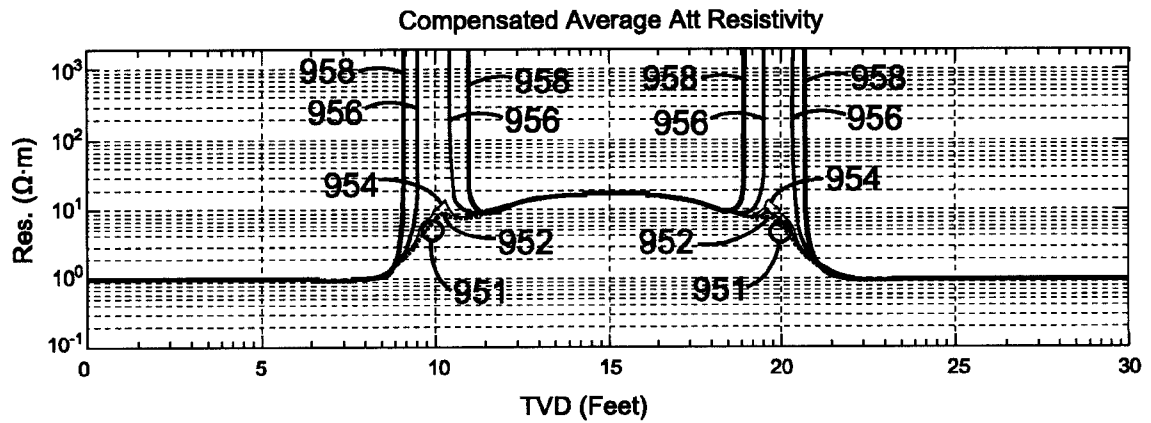

Fig. 9B

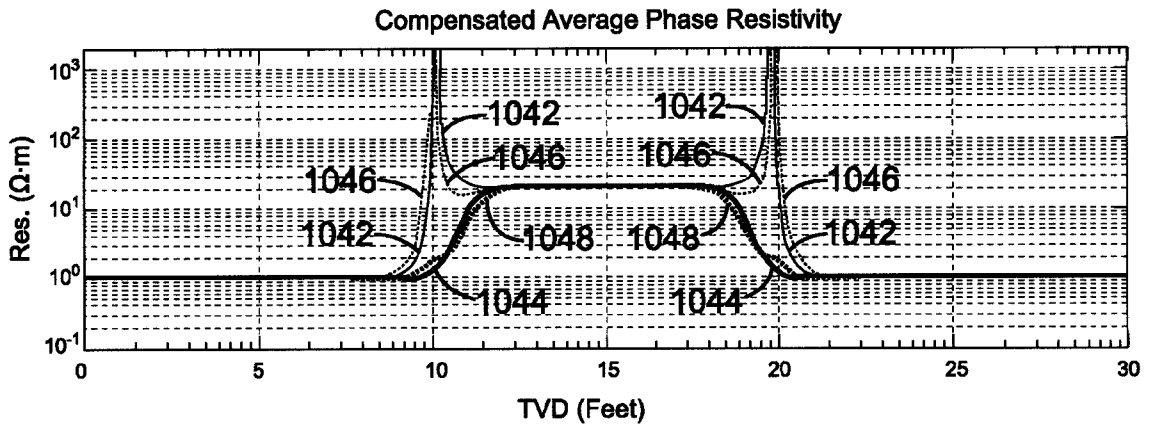

Fig. 10A

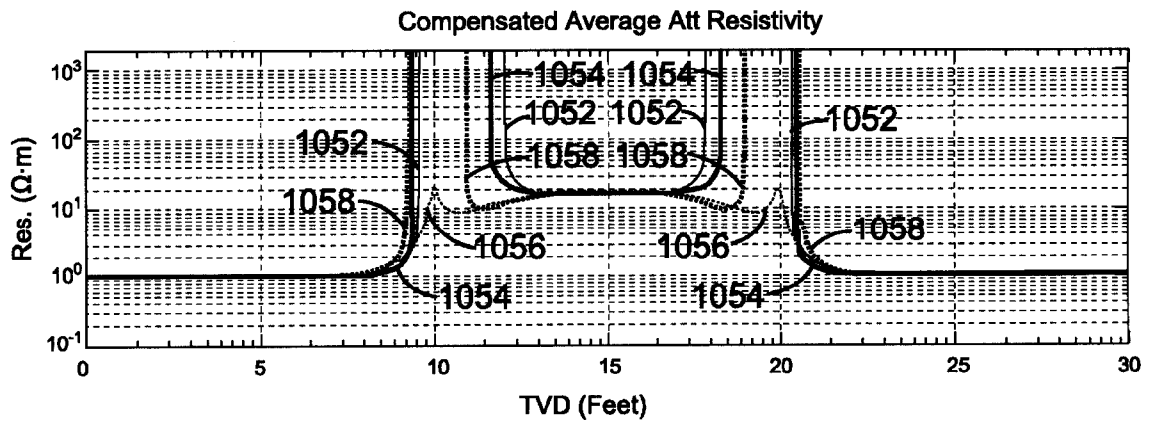

Fig. 10B

9/18

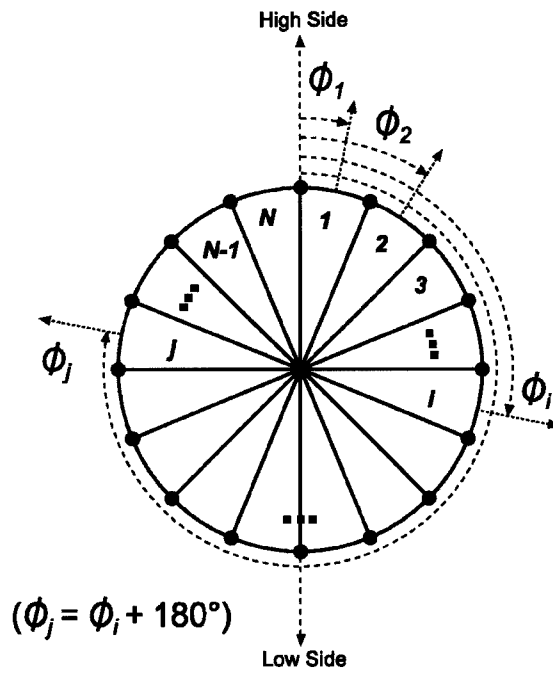

Fig. 11

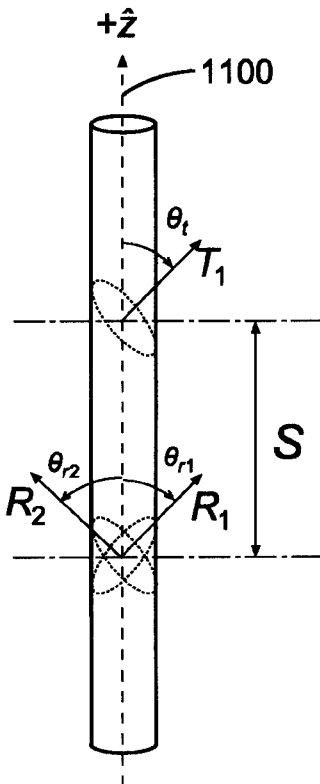

Fig. 12A

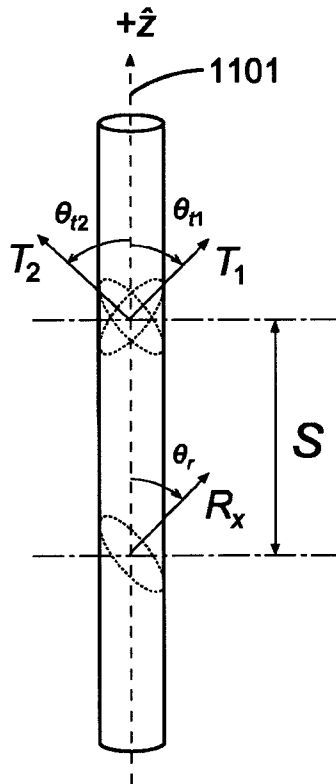

Fig. 12B

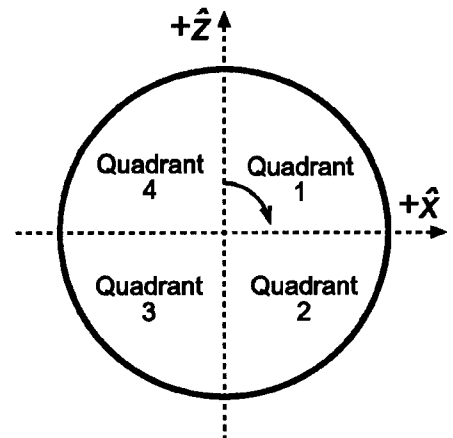

Fig. 12C

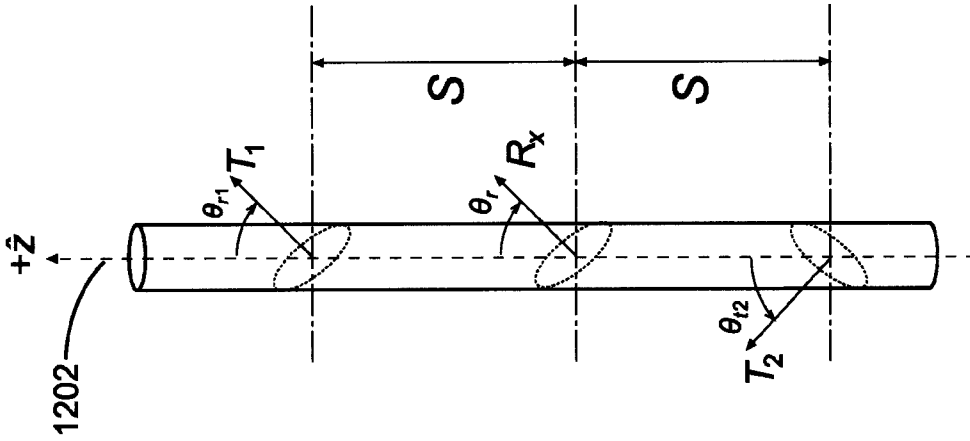

Fig. 13c

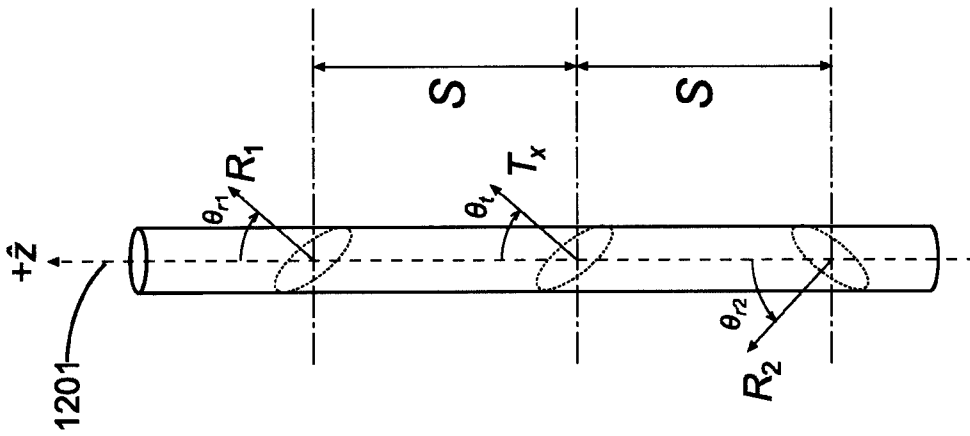

Fig. 13B

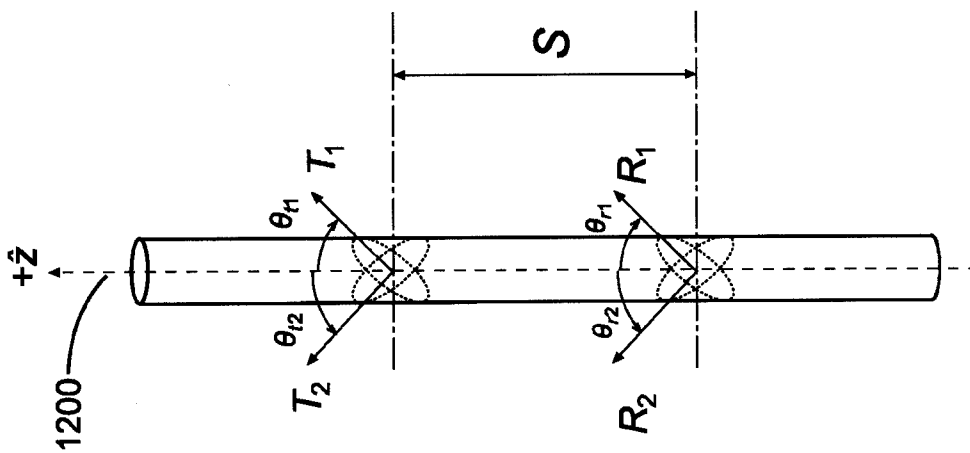

Fig. 13A

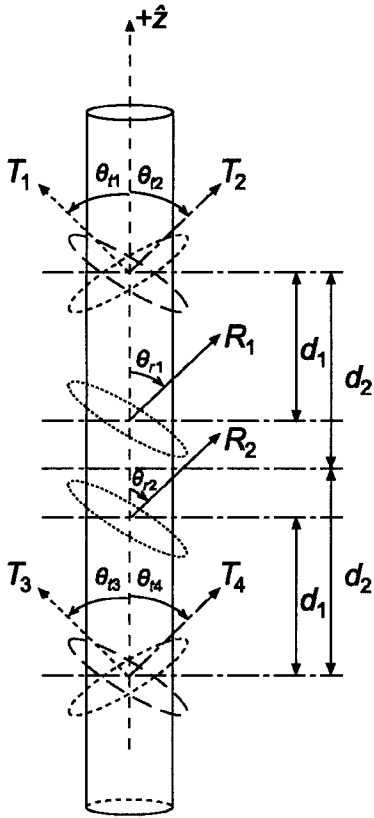

Fig. 14A

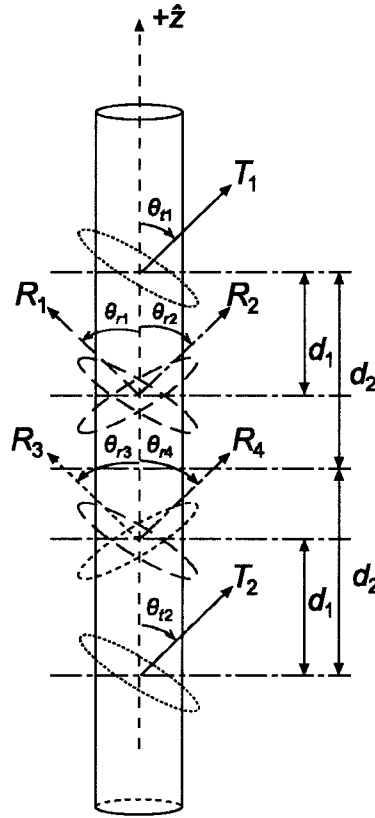

Fig. 14B

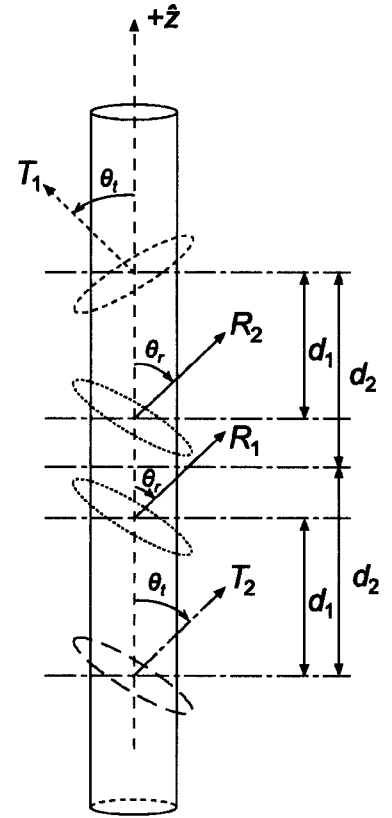

Fig. 14c

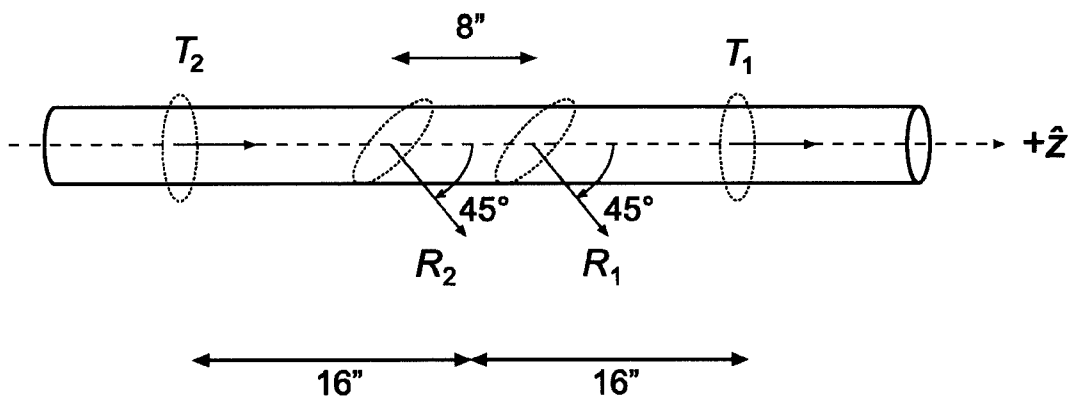

Fig. 15

12/18

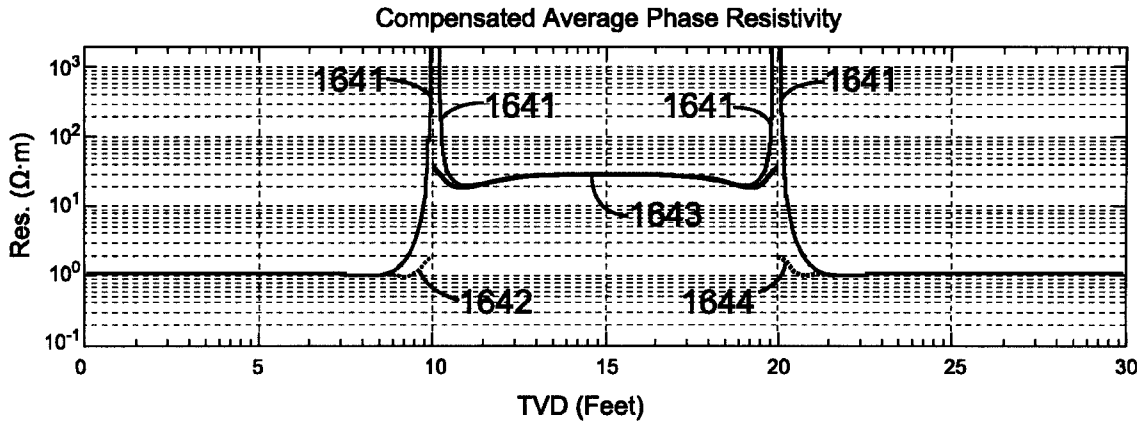

Fig. 16A

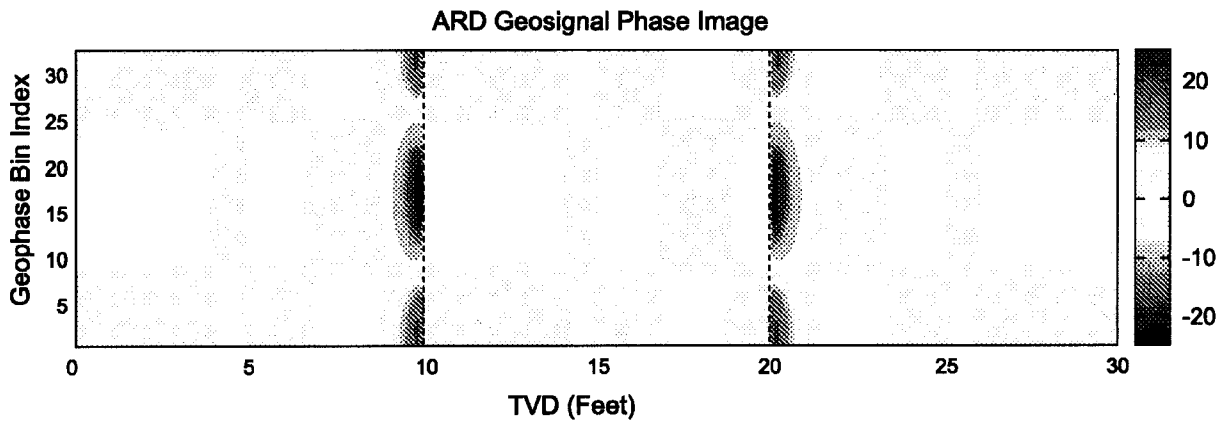

Fig. 16B

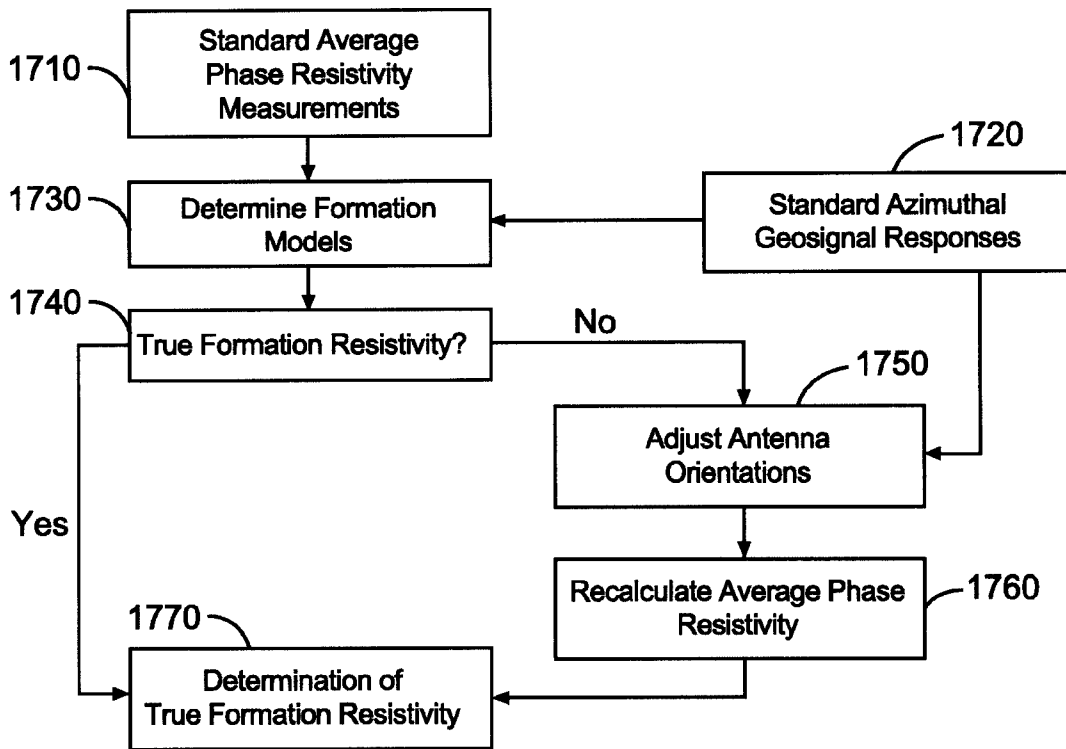

Fig. 17

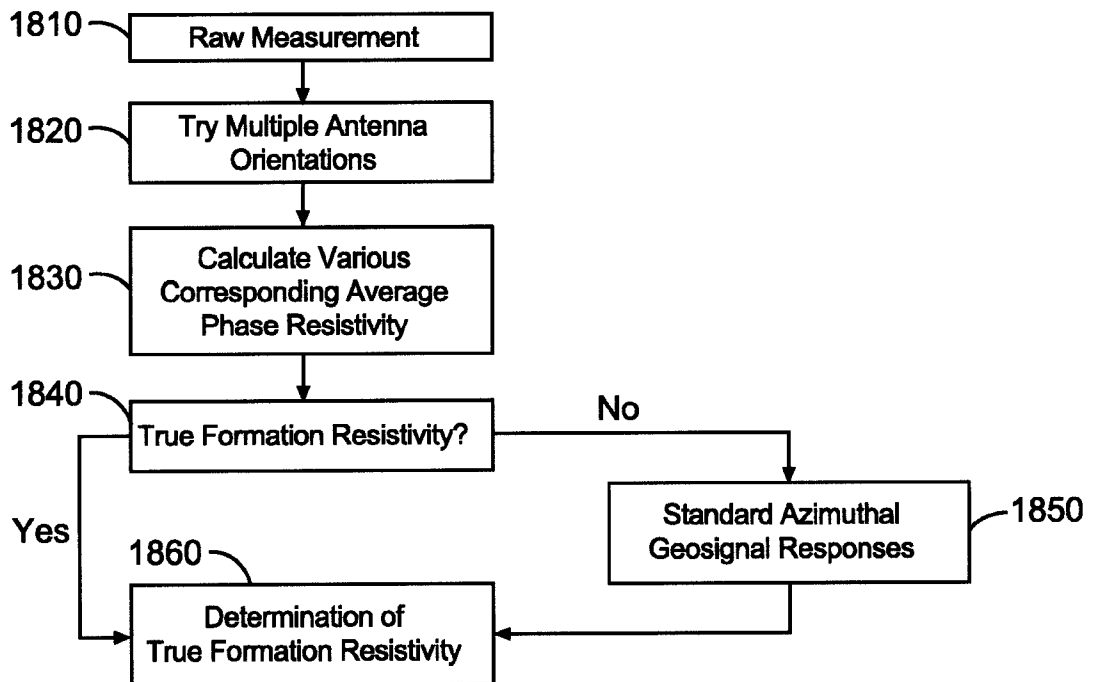

Fig. 18

14/18

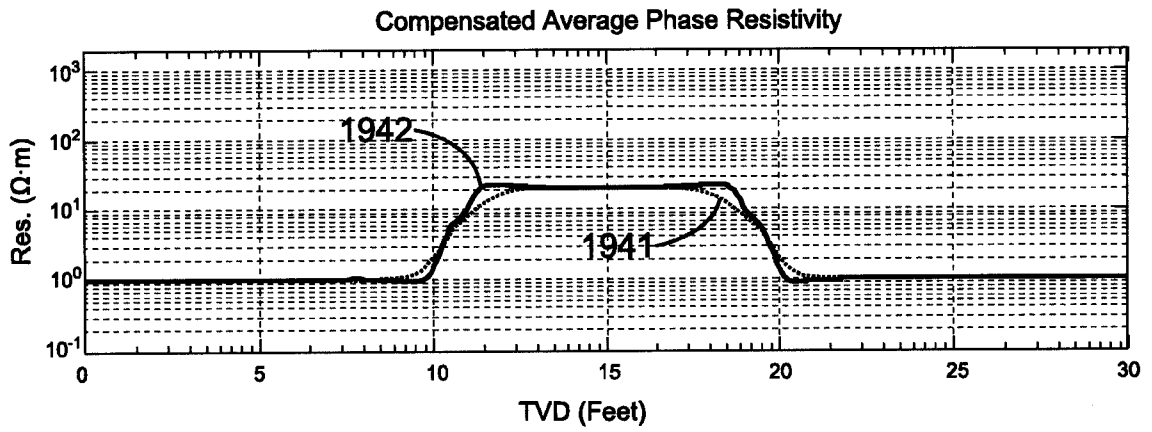

Fig. 19A

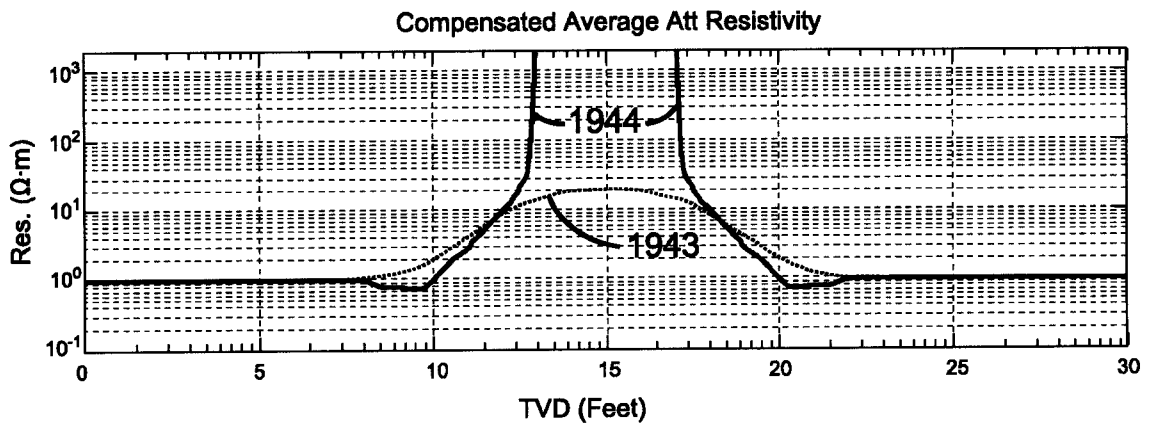
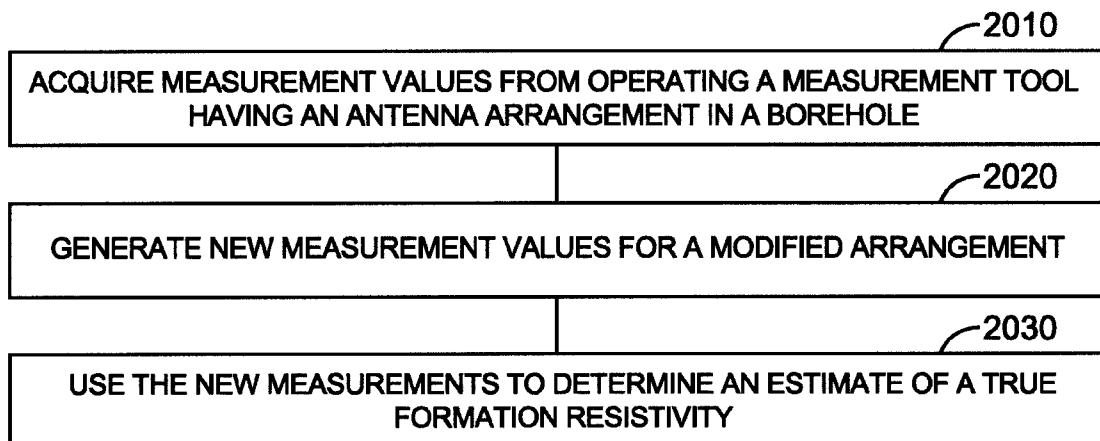
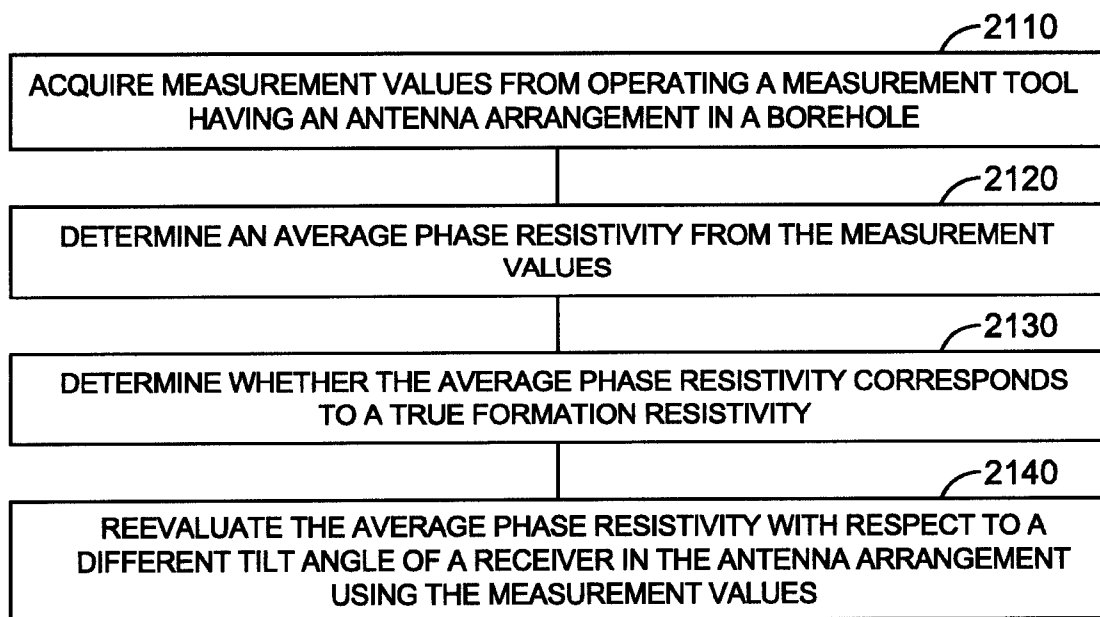

Fig. 19B

15/18

**Fig. 20****Fig. 21**

16/18

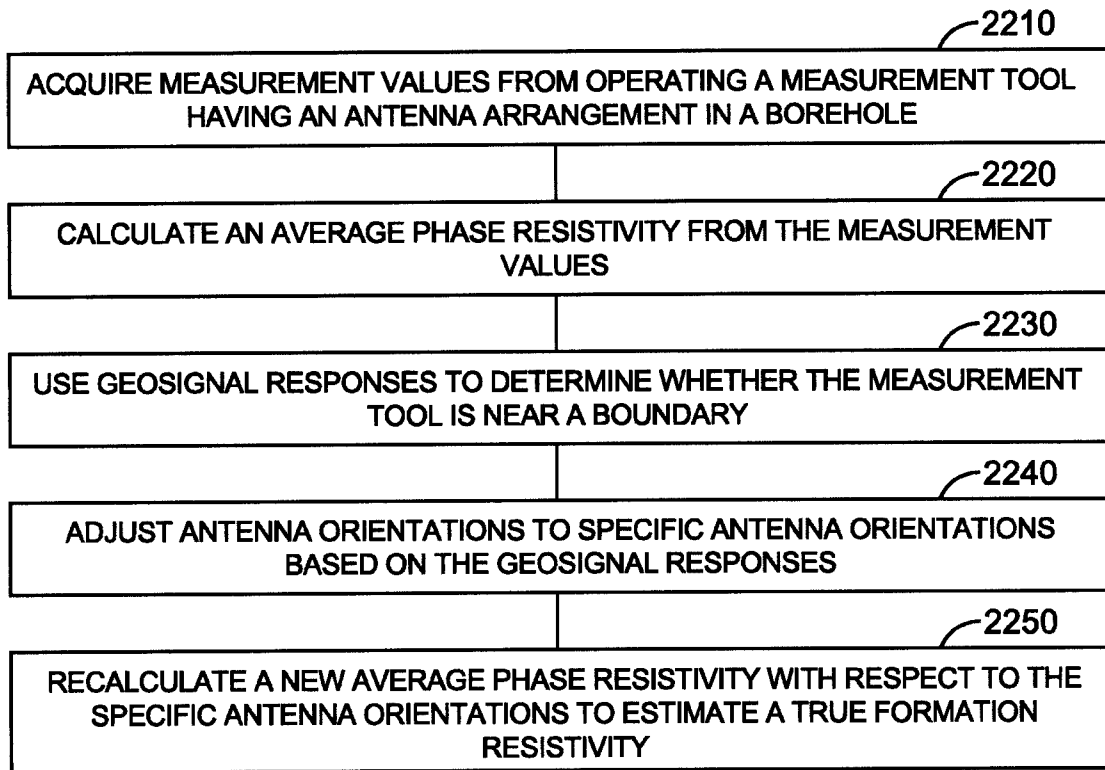

Fig. 22

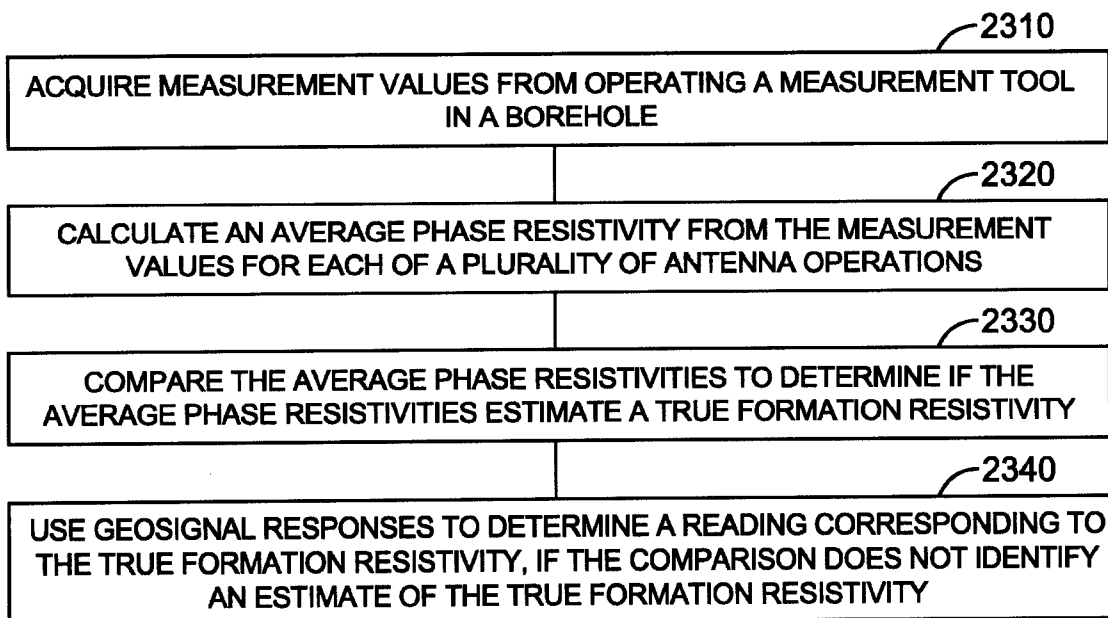

Fig. 23

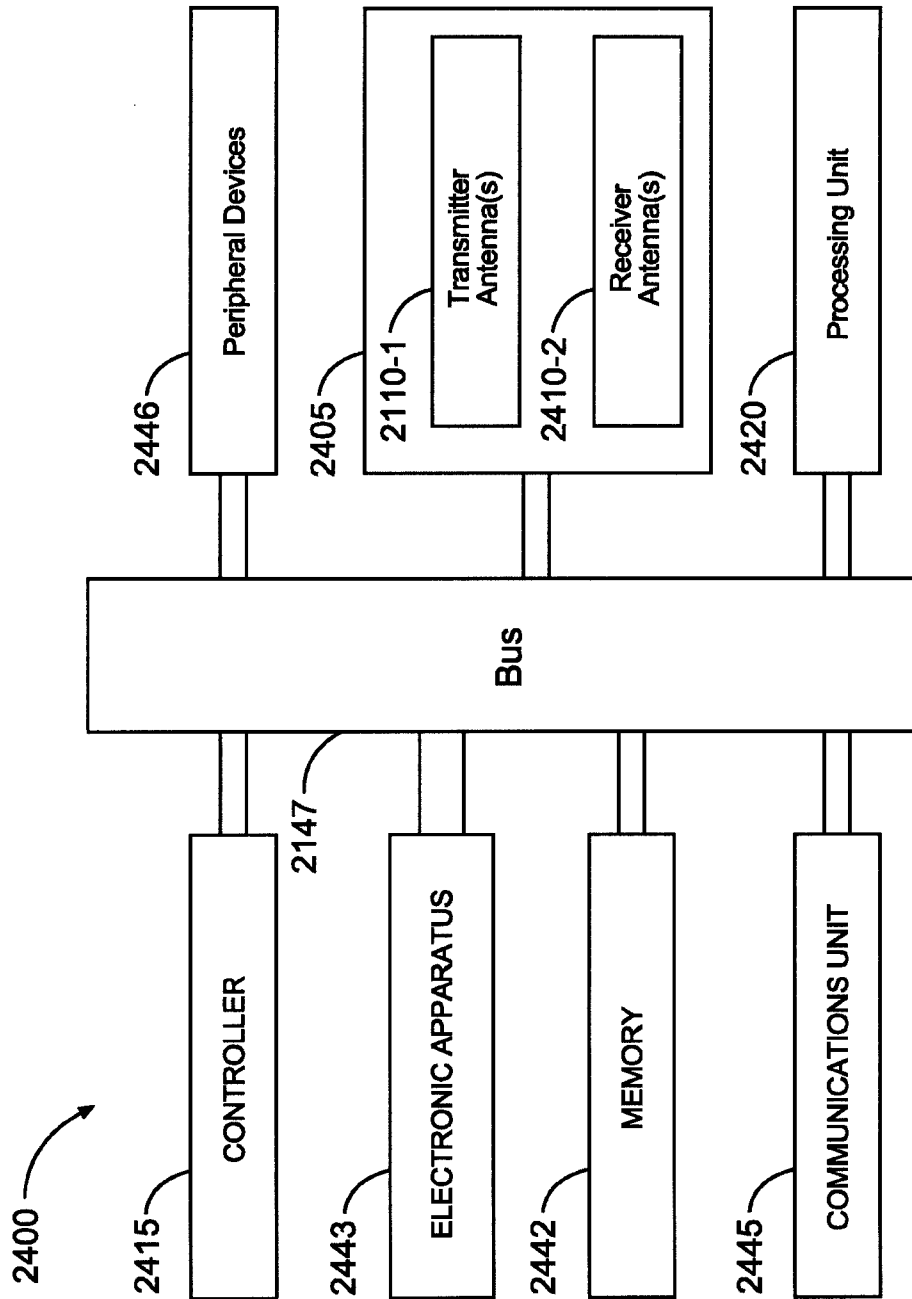

Fig. 24

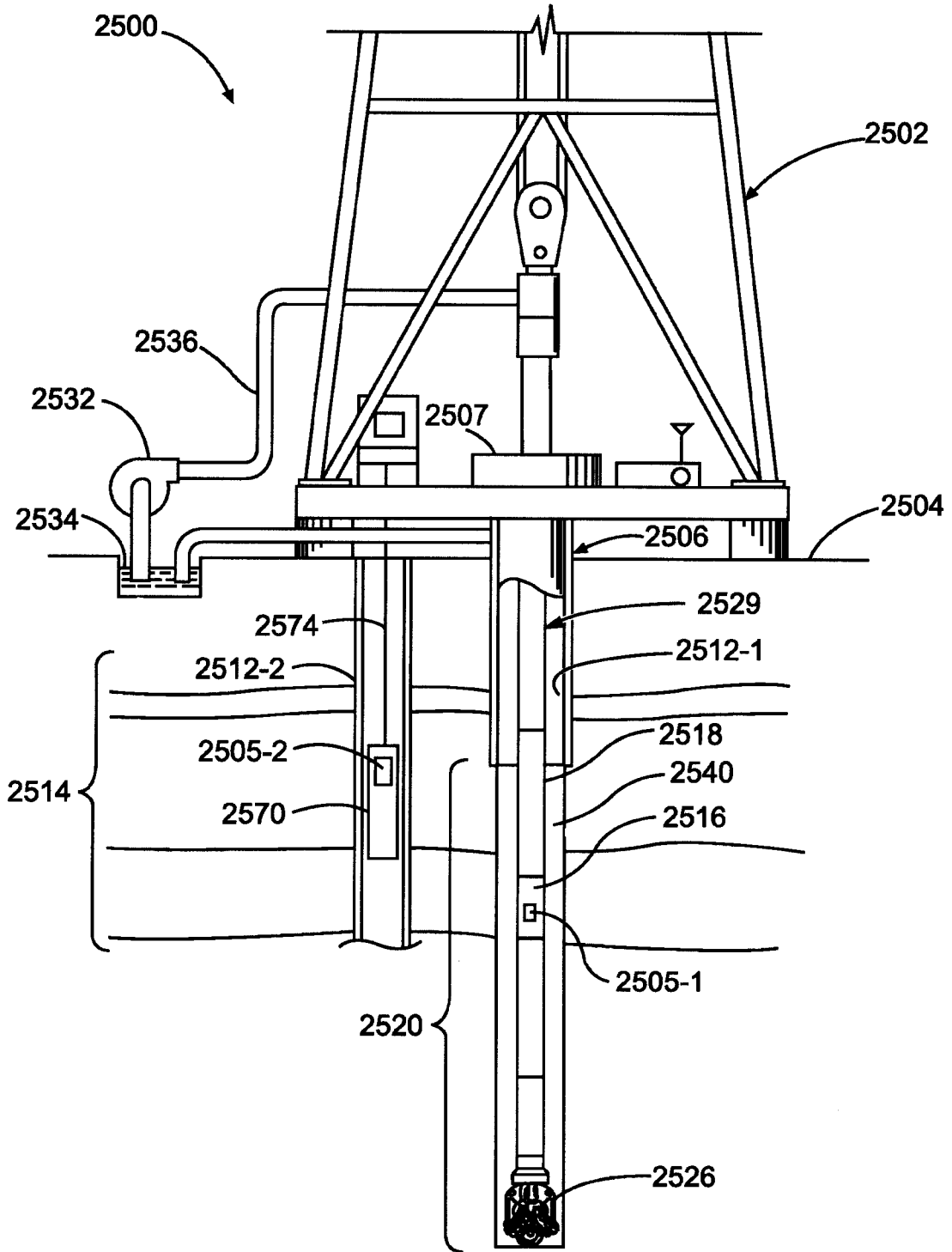

Fig. 25

2010

ACQUIRE MEASUREMENT VALUES FROM OPERATING A MEASUREMENT TOOL
HAVING AN ANTENNA ARRANGEMENT IN A BOREHOLE

2020

GENERATE NEW MEASUREMENT VALUES FOR A MODIFIED ARRANGEMENT

2030

USE THE NEW MEASUREMENTS TO DETERMINE AN ESTIMATE OF A TRUE
FORMATION RESISTIVITY