

PCT

WORLD INTELLECTUAL
Internat

WO 9604404A1

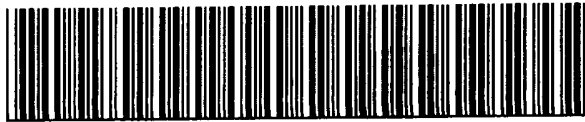

INTERNATIONAL APPLICATION PUBLISHED UNDER THE PATENT COOPERATION TREATY (PCT)

<p>(51) International Patent Classification ⁶ : C12Q 1/68</p>	<p>A1</p>	<p>(11) International Publication Number: WO 96/04404 (43) International Publication Date: 15 February 1996 (15.02.96)</p>
<p>(21) International Application Number: PCT/US95/09905 (22) International Filing Date: 3 August 1995 (03.08.95) (30) Priority Data: 08/285,385 3 August 1994 (03.08.94) US (60) Parent Application or Grant (63) Related by Continuation US 08/285,385 (CIP) Filed on 3 August 1994 (03.08.94) (71) Applicants (for all designated States except US): MOSAIC TECHNOLOGIES, INC. [US/US]; 255 Broadway, Winter Hill, MA 02145 (US). WHITEHEAD FOR BIOMEDICAL RESEARCH [US/US]; 9 Cambridge Center, Cambridge, MA 02142 (US). (72) Inventors; and (75) Inventors/Applicants (for US only): ADAMS, Christopher, P. [US/US]; 255 Broadway, Winter Hill, MA 02145 (US). KRON, Stephen, Joseph [US/US]; 427 Marlboro Street, Boston, MA 02115 (US).</p>		<p>(74) Agent: JANIUK, Anthony, J.; Wolf, Greenfield & Sacks, P.C., 600 Atlantic Avenue, Boston, MA 02210 (US). (81) Designated States: CA, JP, US, European patent (AT, BE, CH, DE, DK, ES, FR, GB, GR, IE, IT, LU, MC, NL, PT, SE). Published <i>With international search report. Before the expiration of the time limit for amending the claims and to be republished in the event of the receipt of amendments.</i></p>

(54) Title: METHOD AND APPARATUS FOR PERFORMING AMPLIFICATION OF NUCLEIC ACID ON SUPPORTS

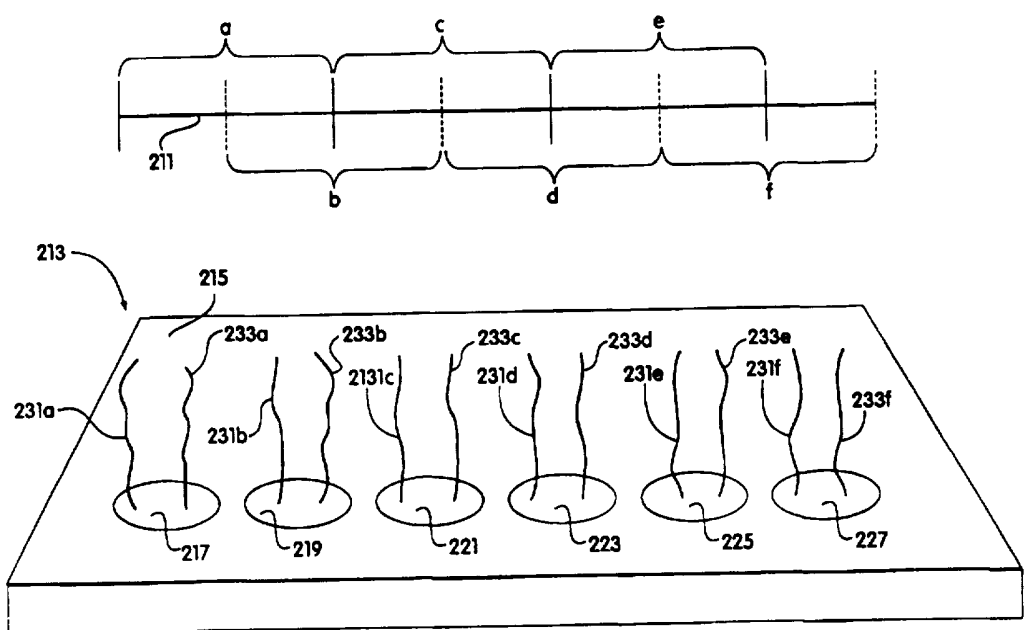

(57) Abstract

This invention features methods and apparatus for performing nucleic acid hybridization and amplification processes on a support. Such methods and apparatus are useful for synthesizing nucleic acid and detecting target nucleic acid for diagnostics and therapeutics.

FOR THE PURPOSES OF INFORMATION ONLY

Codes used to identify States party to the PCT on the front pages of pamphlets publishing international applications under the PCT.

AT	Austria	GB	United Kingdom	MR	Mauritania
AU	Australia	GE	Georgia	MW	Malawi
BB	Barbados	GN	Guinea	NE	Niger
BE	Belgium	GR	Greece	NL	Netherlands
BF	Burkina Faso	HU	Hungary	NO	Norway
BG	Bulgaria	IE	Ireland	NZ	New Zealand
BJ	Benin	IT	Italy	PL	Poland
BR	Brazil	JP	Japan	PT	Portugal
BY	Belarus	KE	Kenya	RO	Romania
CA	Canada	KG	Kyrgystan	RU	Russian Federation
CF	Central African Republic	KP	Democratic People's Republic of Korea	SD	Sudan
CG	Congo	KR	Republic of Korea	SE	Sweden
CH	Switzerland	KZ	Kazakhstan	SI	Slovenia
CI	Côte d'Ivoire	LI	Liechtenstein	SK	Slovakia
CM	Cameroon	LU	Luxembourg	SN	Senegal
CN	China	LK	Sri Lanka	TD	Chad
CS	Czechoslovakia	LV	Latvia	TG	Togo
CZ	Czech Republic	MC	Monaco	TJ	Tajikistan
DE	Germany	MD	Republic of Moldova	TT	Trinidad and Tobago
DK	Denmark	MG	Madagascar	UA	Ukraine
ES	Spain	ML	Mali	US	United States of America
FI	Finland	MN	Mongolia	UZ	Uzbekistan
FR	France			VN	Viet Nam
GA	Gabon				

METHOD AND APPARATUS FOR PERFORMING
AMPLIFICATION OF NUCLEIC ACID ON SUPPORTS

FIELD OF THE INVENTION

5 This invention features methods and apparatus for performing nucleic acid hybridization and amplification processes on a support. Such methods and apparatus are useful for synthesizing nucleic acid and detecting target nucleic acid
0 for diagnostics and therapeutics.

BACKGROUND OF THE INVENTION

The following definitions are provided to facilitate an understanding of the present invention. The term "biological binding pair" as used in the present application refers to any
5 pair of molecules which exhibit natural affinity or binding capacity. For the purposes of the present application, the term "ligand" will refer to one molecule of the biological binding pair and the term "antiligand" or "receptor" will refer to the opposite molecule of the biological binding pair. Two
20 complementary strands of nucleic acid are biological binding pairs. One of the strands is designated the ligand and the other strand is designated the antiligand. However, biological binding pairs may also comprise antigens and antibodies, drugs and drug receptor sites and enzymes and enzyme substrates.

25 The term "probe" refers to a ligand of known qualities capable of selectively binding to a target antiligand. As applied to nucleic acids, the term "probe" refers to a strand of nucleic acid having a base sequence complementary to a target base sequence. Typically, the probe is associated with
30 a label to identify a target base sequence to which the probe binds, or the probe is associated with a support to bind to and capture a target base sequence. The term "primer" is used to refer to nucleic acid having a base sequence complementary to a target base sequence, which upon nucleic acid hybridization is
35 used to promote a reaction. These reactions usually involve enzymes called polymerases and transcriptases.

-2-

The term "label" refers to a molecular moiety capable of detection including, by way of example, without limitation, radioactive isotopes, enzymes, luminescent agents, dyes and detectable intercalating agents. The term "agent" is used in a broad sense, in reference to labels, and includes any molecular moiety which participates in reactions which lead to a detectable response. The term "cofactor" is used broadly to include any composition which participates in reactions with a label agent.

The term "support" refers to conventional supports such as beads, particles, dipsticks, fibers, filters, membranes and silane or silicate supports such as glass.

The term "amplify" is used in the broad sense to mean creating an amplification product which may include, by way of example, additional target molecules, or target-like molecules or molecules complementary to the target molecule, which molecules are created by virtue of the presence of the target molecule in the sample. In the situation where the target is a nucleic acid, an amplification product can be made enzymatically with DNA or RNA polymerases or transcriptases.

Genetic information is stored in living cells in threadlike molecules of deoxyribonucleic acid (DNA). In vivo, the DNA molecule is a double helix, each strand of which is a chain of nucleotides. Each nucleotide is characterized by one of four bases: adenine (A), guanine (G), thymine (T), and cytosine (C). The bases are complementary in the sense that due to the orientation of functional groups certain base pairs attract and bond to each other through hydrogen bonding. Adenine in one stand of DNA pairs with thymine in an opposing complementary stand. Guanine in one strand of DNA pairs with cytosine in an opposing complementary strand. In ribonucleic acid (RNA), the thymine base is replaced by uracil (U) which pairs with adenine in an opposing complementary strand.

DNA consists of covalently linked chains of deoxribonucleotides and RNA consists of covalently linked chains of ribonucleotides. The genetic code of a living

-3-

organism is carried upon DNA in the sequence of the base pairs. Proteins are made or expressed by living organisms in a process in which a DNA sequence is transcribed to a RNA sequence and the RNA sequence translated into proteins.

5 Each nucleic acid is linked by a phosphodiester bridge between the five prime hydroxyl group of the sugar of one nucleotide and the three prime hydroxyl group of the sugar of an adjacent nucleotide. Each linear strand of naturally occurring DNA or RNA has one terminal end having a free five prime hydroxyl group and another terminal end having a three prime hydroxyl group. The terminal ends of polynucleotides are often referred to as being five prime (5') termini or three prime (3') termini in reference to the respective free hydroxyl group. Complementary strands of DNA and RNA form antiparallel complexes in which the 3' terminal end of one strand is oriented to the 5' terminal end of the opposing strand.

Nucleic acid hybridization assays detect the tendency of pairs of nucleic acid strands to pair with greatest stability if they contain regions of complementary sequence. Each pair of complementary nucleotides, between two strands, increases the stability of pairing between a biological binding pair formed between the two nucleic acids. DNA segments isolated from a growing organism are generally duplex DNA, a pair of perfectly complementary strands whose pairing is very stable. The term "hybridize" refers to imposing conditions which promote such pairing. The term "denature" refers to imposing conditions which discourage such pairing. These conditions are imposed by adjusting ionic strength, pH or temperature.

30 Polymerases and transcriptases are enzymes which, in the presence of appropriate reaction conditions, produce a complementary copy of a strand of DNA or RNA. The strand that is copied is called the template DNA or RNA.

35 A polymerase chain reaction, PCR, uses a pair of nucleic acid primers to synthesize copies of target nucleic acid. One primer hybridizes to a target sequence on a first strand, and a second primer hybridizes to a second target sequence on the

-4-

second strand. This permits the amplification product directed by one of the pair of primers to serve as a template for synthesis directed by the second member of the pair of primers. PCR is carried out using a solution containing both members of the pair of primers and a polymerase capable of withstanding conditions required to denature paired strands of DNA.

The identification of unique DNA or RNA sequence or specific genes within the total DNA or RNA extracted from tissue or culture samples may indicate the presence of physiological or pathological conditions. In particular, the identification of unique DNA or RNA sequences or specific genes, within the total DNA or RNA extracted from human or animal tissue, may indicate the presence of genetic diseases or conditions such as sickle cell anemia, tissue compatibility, cancer and precancerous states, or bacterial or viral infections. The identification of unique DNA or RNA sequences or specific genes within the total DNA or RNA extracted from bacterial cultures or tissue containing bacteria may indicate the presence of antibiotic resistance, toxins, viruses, or plasmids, or provide identification between types of bacteria.

Thus, nucleic acid hybridization assays have great potential in the diagnosis and detection of disease. Further potential exists in agricultural and food processing where nucleic acid hybridization assays may be used to detect plant pathogenesis or toxin-producing bacteria.

Much research is presently directed to identifying the nucleic acid sequences which define organisms. An initial step in the process is the identification of regions within the nucleic acid, a process known as mapping. These regions may be subjected to further sequencing. Both the mapping process and the sequencing process are slow and tedious.

SUMMARY OF THE INVENTION

The present invention features methods, articles of manufacture and devices for forming an amplification product in the presence of a first nucleic acid having a target sequence. The methods, articles of manufacture and devices feature the

-5-

amplification of a first nucleic acid without the use of solution base primer pairs. The method, articles of manufacture and instruments allow the performance of multiple simultaneous amplification reactions for rapid analysis of nucleic acids. The amplification reactions do not require the presence of an external reaction chamber, or the presence or use of gels for the analysis of the amplification product.

One embodiment of the present invention features a method for forming an amplification product in the presence of a first nucleic acid having a first target sequence. The method comprises the steps of forming an immersion product comprising a sample potentially containing the first nucleic acid, and a support. The support has a second nucleic acid having a sequence complementary to the target sequence. The second nucleic acid is covalently linked to the support. The method further comprises the step of forming a hybridization product comprising the first nucleic acid and the second nucleic acid, in the event the first nucleic acid is present in the sample. The hybridization product is formed by imposing hybridization conditions on the immersion product. The method further comprises the step of forming a first amplification product comprising a nucleic acid complementary to the first nucleic acid covalently extending from said second nucleic acid.

Preferably, the first nucleic acid comprises a second target sequence and the support comprises a third nucleic acid homologous to the second target sequence. Preferably, the method further comprises the step of releasing the first nucleic acid from the second nucleic acid by imposing the denaturation conditions on the immersion product. Release of the first nucleic acid allows the first nucleic acid to participate in further hybridization reactions.

Preferably, the release of the first nucleic acid also allows the amplification product to participate in further hybridization reactions to form a second hybridization product. Preferably, the method further comprises imposition of a second step of hybridization conditions to form at least one second

-6-

hybridization product. The second hybridization product comprises the first amplification product and a third nucleic acid or the first nucleic acid and a further second nucleic acid. Preferably, upon imposition of second hybridization conditions on the immersion product, the third nucleic acid forms a second hybridization with the first amplification product.

The formation of the second hybridization product allows the additional step of forming a second amplification product comprising nucleic acid complementary to the first amplification product covalently extending from the third nucleic acid. Thus, the first nucleic acid and the first and second amplification products, are capable of participating in a plurality of hybridization and amplification processes, limited only by the initial presence of the first nucleic acid and second and third nucleic acids initially present. Preferably, a plurality of second and third nucleic acids are covalently linked to the support to provide a plurality of first and second amplification products.

Preferably, the second nucleic acid and the third nucleic acid have positions on the support, which are spaced a distance less than the length of the first nucleic acid to allow an amplification product to form between the second and third nucleic acids. Preferably, a plurality of second and third nucleic acids have positions on the support, which are spaced a distance less than the length of the first nucleic acid, to form a plurality of first and second amplification products.

Preferably, the method further comprises the step of monitoring the support for the presence of one or more amplification products which one or more amplification products are indicative of the presence of one or more target sequence and which absence is indicative of the absence of a target sequence. The formation of a plurality of first and second amplification products allows the detection of extremely small numbers of first nucleic acid having target sequence.

-7-

Preferably, the support is epoxy silane derivatized silica. Supports may be filters, fibers, membranes, beads, particles, dipsticks, sheets, rods and the like. Preferably, the support has a composition of plastic, such as nylon or latex for beads, particles, dipsticks and the like; or glass, in the form of glass fiber, glass sheets, beads, rods, dipsticks; or metal, in the form of magnetic particles and the like. A preferred support comprises a sheet which has surfaces with alignment features to allow the precise positioning of the second nucleic acid and third nucleic acids, to define areas of the support directed to a first pair of target sequences and other areas directed to a second pair of target sequences. These areas are preferably arranged in a grid type pattern of pixels.

Preferably, the second nucleic acid is covalently bonded to a hexaethylene glycol functional group which functional group is covalently bonded to the support. However, other functional groups can be used to covalently bond DNA with a support. Preferably, the second nucleic acid is covalently bonded to the hexaethylene glycol functional group to a 5' amino group. The hexaethylene glycol functional group positions the second nucleic acid away from the support to allow the second nucleic acid to interact with the first nucleic acid and enzymes used to form the amplification product.

Preferably, the first nucleic acid has a size of approximately 1 to 10 kb. Larger nucleic acids can be readily digested by enzymes or mechanically fragmented. Preferably, the second and third nucleic acid have a density or concentration on the support to allow spacing between such second and third nucleic acid less than the size of the first nucleic acid. Thus, the size of the first nucleic acid cooperates with the density concentration or spacing of second and third nucleic acids to allow amplification products to form there between.

-8-

As used herein, the term "immersion product" refers to a support that is covered with a sample and other reagents about the nucleic acids covalently bonded to its surface. By way of example, making an immersion product may comprise placing a dipstick into a solution or placing beads in a solution, or wetting a slide or glass surface with a solution.

The term "hybridization product" refers to the product of a hybridization reaction. The term "amplification product" refers to a molecule or part of a molecule which has been made or extended by virtue of another molecule being present.

Preferably, the amplification product is formed by imposing amplification conditions on the immersion product.

Amplification conditions comprise applying a thermal stable polymerase nucleotides and other necessary reagents for a polymerase reaction to the hybridization product under conditions of temperature, ionic strength, and pH to support a polymerase reaction. As used herein, the term "applying" means contacting or placing in proximity of an object in a manner such that the subject may act upon the object in the intended manner.

Preferably, the amplification product incorporates a label capable of detection. Preferred labels include radioisotopes, and chemiluminescent, luminescent and fluorescent agents and cofactors. However, where the amplification product participates in hybridization reactions to form a further hybridization product, such product can be detected with intercalating agents. In the alternative, the amplification product can be detected by a fourth nucleic acid probe which probe is complementary or homologous to a third target sequence derived from the first nucleic acid and present on one or more of the amplification products. The fourth nucleic acid probe detects the correct nucleic acid sequence of the amplification product to reduce false positives.

Embodiments of the present method can be used to quantitate the amount of first nucleic acids having a target sequence. The number of cycles and the amount of signals

generated by the amplification product relate to the amount of first nucleic acid having a target sequence initially present.

One embodiment of the present method features a support with many sets of second and third nucleic acids, with each set directed to a different first nucleic acid. Preferably, each set of second and third nucleic acids are positioned in discrete areas of the support. Each support may comprise a plurality of sets to a plurality of first nucleic acids and targets. Preferably, at least one set has a second and third nucleic acid having a nonsense sequence, which nonsense sequence is not intended under hybridization and amplification conditions to generate an amplification product as a negative control. Preferably, at least one set has a second and third nucleic acid having a sequence which is universally present in almost all samples, or is directed to a nucleic acid sequence present in the sample as a positive control.

Embodiments of the present method are also useful for mapping large nucleic acids. One embodiment of the present invention features sets of second and third nucleic acids. Each set is directed to a first nucleic acid which first nucleic acid is part of a large nucleic acid. The sets of second and third nucleic acids generate sets of first and second amplification products. The sets of first and second amplification products span overlapping sequences of the large nucleic acid. As used herein, "overlapping" refers to two nucleic acids having at least one identical nucleotide sequence directed to an area of nucleic acid from which they were derived or to which they are intended to hybridize. These overlapping sequences can be correlated to produce a map of the large nucleic acid. The present invention can be used to replace the use of sequence tag sites by using an array of amplification products.

One embodiment of the present invention features a method which is capable of forming a precipitate or agglutination product in the presence of a first nucleic acid having a target sequence. This method features a first support having a second

nucleic acid and a second support having a third nucleic acid. The method comprises forming an immersion product of the first and second support with a sample potentially containing the first nucleic acid. Next, hybridization conditions are imposed on the immersion product to form a first hybridization product comprising the first nucleic acid and the second nucleic acid. Next, amplification conditions are imposed on the hybridization product to form a first amplification product. The third nucleic acid has a sequence identical to a second target sequence. That is, the third nucleic acid is complementary to at least a section of the first amplification product. The method further comprises forming a second hybridization product comprising the third nucleic acid and the first amplification product extending from the first support. This second hybridization product can promote an agglutination or precipitation of the immersion product.

Preferably, this hybridization product is further stabilized by forming a second amplification product comprising a nucleic acid extending from the third nucleic acid complementary to the first amplification product.

Preferably, the immersion product comprises a suspension of supports. Each support having a plurality of second and third nucleic acids which upon cycling through hybridization, denaturation and amplification conditions form an agglutination product.

The present method is ideally suited for applications utilizing carboxylated latex particles, plastic or glass beads which can precipitate from solutions upon the formation of a second hybridization product or a second amplification product.

A further embodiment of the present invention features an article of manufacture for forming an amplification product in the presence of a first nucleic acid having a target sequence. The article of manufacture comprises a support having a second nucleic acid having a nucleotide sequence complementary to the target sequence, which second nucleic acid is covalently bound to the support. The support is capable of forming an immersion

-11-

product with a sample potentially containing the first nucleic acids, undergoing hybridization conditions and undergoing amplification conditions to form a first hybridization product and a first amplification product in the presence of the first nucleic acid. The first amplification product extends from the second nucleic acid and is complementary to the first nucleic acid.

Preferably, the article of manufacture further comprises a third nucleic acid in which the third nucleic acid is complementary to the first amplification product. The third nucleic acid is capable of forming a second hybridization product with a target sequence of the first amplification upon imposition of hybridization conditions. That is, the third nucleic acid is homologous to a second target sequence of the first nucleic acid. Preferably, the third nucleic acid is capable of priming a reaction to form a second amplification product.

Preferably, the second and third nucleic acid have a spaced relationship. The positions are separated by a distance less than the length of the first target sequence and the second target sequence of the first nucleic acid. In the alternative, the second and third nucleotides are randomly immobilized in a concentration or density on the support such that first and second nucleic acids have a spaced relationship.

Preferably, each set occupies a defined region of the support to form a pixel-like area. The amplification product occurs in the defined region and is termed the test site or test pixel.

Preferably, in order to effect mapping of a first nucleic acid, the support has a plurality of sets of second and third nucleic acids. Each set corresponds to a first nucleic acid which first nucleic acid is part of a large nucleic acid. The first nucleic acid for each set preferably has overlapping sequences to allow mapping of the first nucleic acid by matching the overlapping area.

-12-

Embodiments of the present invention are well suited for automation. A further embodiment of the present invention features an instrument for forming an amplification product in the presence of a first nucleic acid having a target sequence. The instrument comprises means for receiving a support having a second nucleic acid having a nucleotide sequence complementary to the target sequence. The second nucleic acid is covalently bound to the support. The instrument further comprises means for forming an immersion product comprising the support and the sample. The instrument further comprises means for imposing hybridization conditions on the immersion product for forming a hybridization product in the presence of the first nucleic acid. The instrument further comprises means for imposing amplification conditions on the hybridization product, if formed, to form an amplification product. The formation of the amplification product can be related to the presence of the first nucleic acid and the target sequence.

Means for forming an immersion product may comprise apparatus for depositing a sample on a support containing the second nucleic acid or means for placing the solid support within a containment vessel containing the sample.

Means for imposing hybridization conditions comprises devices such as dispensing orifices, pipettes and the like for placing suitable buffers with the immersion product and temperature controls to effect hybridization of nucleic acid.

Means for imposing amplification conditions comprises devices such as dispensing orifices, pipettes and the like for placing enzymes and reagents for extending nucleic acid or duplicating nucleic acid. Typical reagents include polymerases, nucleotides, buffers and the like. The conditions for imposing hybridization conditions and amplification conditions are well known to individuals skilled in the art.

Thus, the present invention features methods, devices and articles of manufacture for the detection of nucleic acid having a particular target sequence without using solution based primer sets. The present invention facilitates the

-13-

performance of simultaneous target amplification reactions, greatly shortening the time to generate data necessary to map nucleic acids. The absence of an external reaction chamber and a gel base system for the analysis of amplified products greatly facilitates the analysis of the assay results.

These and other features will become apparent from the drawings and the detailed description which follow which, by way of example, without limitation, describe preferred embodiments of the present invention.

BRIEF DESCRIPTION OF THE DRAWINGS

Figures 1A through 1M depict schematically a method, article of manufacture and instrument for making amplification products;

Figures 2A through 2L depict schematically a method, article of manufacture and instrument for making amplification products in accordance with the present invention;

Figure 3 depicts a article of manufacture, in the form of a support, for mapping regions of a first nucleic acid in accordance with the present invention; and

Figure 4 depicts the kinetics of a process in accordance with the present invention;

DETAILED DESCRIPTION OF THE INVENTION

This invention features methods and apparatus for performing nucleic acid hybridization and amplification processes on a support. The practice of the present invention will employ, unless otherwise indicated, conventional techniques of chemistry, molecular biology, microbiology, recombinant DNA and immunology, which are within the skill of the art. Such techniques are explained fully in the literature. See: for example, e.g., Maniatis, Fritch and Sambrook, Molecular Cloning: A Laboratory Manual (1982); DNA Cloning, Volumes 1 and 2 (D.N. Glover Ed. 1985); Oligonucleotide Synthesis (M.J. Gait ed, 1984); Nucleic Acid Hybridization (B.D. Hames & S.J. Higgins eds. 1984); the series, Methods in Enzymology (Academic Press, Inc.), particularly Vol. 154 and Vol. 155 (Wu and Grossman, eds.).

-14-

Turning now to Figures 1A and 1M, an article of manufacture, a plurality of carboxylated latex beads, generally designated by the numeral 11a and 11b, for making an amplification product is depicted. The presence of an amplification product will be used to indicate the presence of two target sequences of a first nucleic acid. Latex beads 11a and 11b have at least one second nucleic acid, and preferably, a plurality of second nucleic acids which will act as primers in an amplification reaction. The second nucleic acid is affixed covalently through a 5' linkage and the carboxylated functional group of the latex bead. As illustrated, each latex bead 11a and 11b has a second nucleic acid 13 and a third nucleic acid 15 for purposes of simplicity, with the understanding that many more second and third nucleic acids 13 and 15 may be present. The representations of the latex beads 11a and 11b and second and third nucleic acids 13 and 15 are for illustrative purposes and are not drawn to scale.

The methods of the present invention can be performed manually or in an automated instrument. In an instrument format Figures 1A-1M represent an instrument. Each Figure 1A to 1M represents a work station with a double arrow representing conveying means. Conveying means may comprise rotatable turntables, conveying belts and the like.

In Figure 1A, latex beads 11a and 11b are depicted as being suspended in a aqueous solution 19 contained within a vessel 17. Solution 19 and/or beads 11a and 11b are dispensed into vessel 17 by a dispensing orifice 21 or may be prepackaged in vessel 17.

Figure 1B illustrates the addition of a first nucleic acid 23 derived from a sample, to vessel 17. First nucleic acid 23 may be placed in vessel 17 prior to beads 11a and 11b or after as illustrated. First nucleic acid 23 may be placed in vessel 17 by means of an orifice such as orifice 21 depicted in Figure 1A. First nucleic acid 23 is double stranded DNA, comprising a first strand 25 and a second strand 27. Each strand has two target sequences a and b. Second nucleic acid 13 is

-15-

complementary to target sequence a of strand 25 and homologous to sequence a of strand 27. Third nucleic acid 15 is homologous to target sequence b of strand 25 and complementary to sequence b of strand 25. First nucleic acid 23 and latex beads 11a and 11b form an immersion product.

Figure 1C depicts the immersion product, latex beads 11a and 11b and first nucleic acid undergoing denaturation conditions. Denaturation conditions are imposed at a workstation by suitable means such as controlling temperature, and/or ionic strength, and/or the pH of solution 19 contained in vessel 17.

The immersion product, comprising the first nucleic acid and the latex beads 11a and b, is next subjected to hybridization condition as represented in Figure 1D. Hybridization conditions are preferably performed at a workstation by adjusting one or more factors influencing hybridization, including temperature, and/or ionic strength and pH.

Figure 1D depicts a hybridization product comprising first nucleic acid strand 25 and second nucleic acid 13 of latex bead 11a. First nucleic acid strand 27 may also have target areas [not shown] which interact with further primers [not shown]. For purposes of simplicity and clarity, this discussion will focus on strand 25 and target sequence a and b.

The hybridization product, comprising first nucleic acid strand 25 and second nucleic acid 13 of latex bead 11a, is next subjected to amplification conditions, as represented in Figure 1E. Amplification conditions are preferably imposed at a workstation by adding suitable reagents for amplification, including a thermal stable polymerase, nucleotides and other necessary reagents, buffers and the like. Thus, a workstation as represented by Figure 1e will receive vessel 17 and add suitable reagents through orifices such as orifice 21 depicted in Figure 1a. Figure 1e depicts a first amplification product 31 covalently extended from first nucleic acid 13. This amplification product is complementary to first nucleic

-16-

acid strand 25. Thus amplification product 31 has a target sequence b which is complementary to third nucleic acid 15 of latex beads 11a or 11b.

5 The first amplification product is next subjected to denaturation conditions at a further work station, as illustrated in Figure 1F. Upon imposition of denaturation conditions, a denaturation product is formed comprising first nucleic acid strands 25 and 27; second and third nucleic acids 13 and 15 of latex beads 11a and 11b; and a first amplification
10 product 31 as illustrated in Figure 1F. Denaturation conditions comprises elevated temperatures, higher salt concentrations and/or lower pH. The work station has means for imposing denaturation conditions such as an orifice 21 depicted in Figure 1a for adding reagents or heating elements [not
15 shown].

The denaturation product is next subjected to hybridization conditions at a further work station as illustrated in Figure 1G. Upon imposition of hybridization conditions, a hybridization product is formed. In one
20 alternative, the hybridization product comprises the first amplification product 31 and third nucleic acid 15 of latex bead 11b; and the first nucleic acid strand 25 and second nucleic acid 13 of latex bead 11b. In the alternative, as illustrated in Figure 1G, a hybridization product forms
25 comprising the first amplification product 31 and third nucleic acid 15 of latex bead 11a; and the first nucleic acid strand 25 and second nucleic acid 13 of latex bead 11b.

Upon imposition of amplification conditions, as illustrated in Figure 1H, a second amplification product 33 is
30 formed. The second amplification product extends from third nucleic acid 15 of latex bead 11a. In the alternative, a second amplification product 33 is formed extending from third nucleic acid 15 of latex bead 11b. A further first amplification product 31 is formed from first nucleic acid 13
35 of latex bead 11b.

-17-

Imposition of further cycles of denaturation, hybridization, amplification and denaturation as depicted in Figure 1I - Figure 1L, form additional first and second amplification products 31 and 33 extending from each second and third nucleic acid 13 and 15 of each latex bead 11a and b. Preferably, the cycles of denaturation, hybridization, amplification and denaturation are performed at work stations. These cycles can be repeated as many times as desired until the second and third nucleic acids 13 and 15 are exhausted.

First and second amplification products 31 and 33 hybridize to each other and allow hybridization between adjacent latex particles 11a and 11b as depicted in Figure 1M. Preferably, hybridization conditions are imposed at a work station of an instrument. The hybridization of first and second amplification products 31 and 33 of adjacent latex beads 11a and 11b disrupts the suspension and the beads 11a and 11b precipitate or agglutinate into a detectable mass. Preferably, this detectable mass is detected by monitoring equipment [not shown]. The formation of the detectable mass is indicative of the presence of the first nucleic acid and, in particular, target sequences a and b of strand 25.

Turning now to Figures 2A through 2J, and in particular, an article of manufacture, generally designated by the numeral 111, for making an amplification product in the presence of a first nucleic acid, is depicted. The article comprises an epoxy silane derivatized support 113 which support has a planar upper surface 117 with two areas 121 and 123. Areas 121 and 123 each contain a probe set comprising a second and a third nucleic acid. The second and third nucleic acids of area designated 121 are designated 125 and 127 respectively. The second and third nucleic acids of area 123 are designated 125' and 127' prime respectively. The representations of the nucleic acids and areas 121 and 123 are for illustrative purposes only and are not drawn to scale. The areas are preferably pixel sized, as the term pixel is used with respect

-18-

to a television screen. These areas are preferably areas of 10 μ^2 to 1 mm^2 .

The support 113 may take many different forms, such as sheets of glass, beads or dipsticks. Individuals skilled in the art can readily modify the shape and size of the support in order to fit individual needs. The entire support 113 may be any convenient size; however, preferably it is shaped to present a planar upper surface 117 of approximately 1 cm^2 .

Turning now to Figure 2B, a sample, generally designated by the numeral 131, is deposited on the support 113 forming an immersion product. Individuals skilled in the art will readily recognize that the support 113 can be totally immersed in a solution or a solution deposited upon the surface of the support in order to apply a sample to the nucleic acid of areas 121 and 123. Sample 131 has a first nucleic acid 133 having target sequences complementary to the second nucleic acid of region 121 and 123. As depicted, means for applying the sample 131 to support 113 comprise a sample dispensing orifice 135.

The methods of the present invention can be performed manually or in an automated instrument. In an instrument format, each Figure represents work stations, with a double arrow representing conveying means. Conveying means may comprise rotatable turntables, conveying belts and the like.

In another format the methods of the present invention can be performed in a self contained reaction cartridge.

Typically, the cartridge contains all of the necessary reagents needed to perform the assay. The cartridge will have a port for introduction of the sample and separate isolated chambers for buffers, enzymes, and detection agents, e.g., dyes or labeled oligonucleotides. The use of microfabrication techniques to manufacture the cartridge leads to increased reaction speeds and reduced reagent concentrations. At programmed intervals, reagents are released from the reagent chambers and delivered to the central reaction site, containing

-19-

the first target nucleotide and the immobilized second and third oligonucleotides.

Turning now to Figure 2C, a third work station is depicted for imposing hybridization conditions on the immersion product. Upon imposition of hybridization conditions, a hybridization product is formed in area 121 comprising a first nucleic acid 133 and a second nucleic acid 125. Hybridization conditions may comprise altering the ionic strength or pH of solutions, or lowering temperature in order to effect the hybridization of the first and second nucleic acids. Means for imposing hybridization conditions are depicted by hybridization dispensing orifice 137 and cooling fan 139.

Turning now to Figure 1D, a fourth work station is depicted for imposing amplification conditions on the hybridization product, if present, to form a first amplification product. The first amplification product 145 comprises a nucleic acid extending from the second nucleic acid 125 corresponding to the first nucleic acid 133. Amplification conditions may comprise the addition of polymerases and transcriptases, nucleotides, buffers and the like necessary to effect an amplification reaction. Reagents to form a first amplification product 145 are dispensed through a dispensing orifice 143.

Figure 2E depicts a fifth work station, which work station may perform one or more functions. The nucleotides incorporated into the amplification product can be labeled in order to effect detection. Thus, the fifth work station may comprise detection means [not shown] to monitor the support 113 for the presence of the amplification product. However, for most detection formats, it is useful to provide additional amplification products to increase signal. Thus, as depicted, the fifth work station imposes denaturation conditions on the amplification product 145 to allow first nucleic acid strand 133 to disassociate from second nucleic acid 125 and first

-20-

amplification product 145. Denaturation reagents are dispersed on support 113 through orifice 147.

Additional signals can be obtained by again forming additional hybridization products. Turning now to Figure 2F, a sixth work station for forming a second hybridization product is illustrated. In the event that the sample has not been removed, the first nucleic acid 133 may still remain to hybridize with nucleic acid 125' of area 123 to effect a further first hybridization product. With respect to the area 121, a second hybridization product is formed between the first amplification product 145 and third nucleic acid 127. Means for imposing hybridization conditions have been described previously. As depicted, hybridization dispensing orifice 149 and cooling fan 151 impose hybridization conditions by adding appropriate buffers, solutions, and salts, and controlling temperature.

Figure 2G depicts a seventh work station for forming a second amplification product 147 in area 121 and a further first amplification product 145' in area 123. Upon imposition of amplification conditions, a second amplification product 147 is formed in the first region 121. The second amplification product 147 comprises a nucleic acid which is complementary to the first amplification product 145. The second amplification product 147 extends from the third nucleic acid 127. A further first amplification product 145' is formed in the second area 123 extending from second nucleic acid 125'. Amplification reagents are applied to support 13 by dispensing orifice 153.

Moving now to Figure 2H, an eighth work station is depicted for imposing denaturation conditions. After denaturation, a first and second amplification product 145 and 147 extend from the second and third nucleic acid 125 and 127 of area 121, and a first amplification product 145' extends from second nucleic acid 125' of region 123. Means for imposing denaturation conditions are depicted generally by dispensing orifice 155 and by heating elements [not shown].

-21-

Turning now to Figure 2I, a ninth work station is depicted for imposing hybridization conditions on the support 113. Upon imposition of hybridization conditions, the first and second amplification products 145 and 147 of area 121 hybridize; and, the first amplification product 145' of region 123 hybridizes to the third nucleic acid 127'. Means for imposing hybridization conditions comprise hybridization reagents applied through dispensing orifice 167, such as suitable buffers, salts and the like, and thermal controls represented by cooling fan 169.

Turning now to Figure 2J, a tenth work station is depicted for imposing amplification conditions upon the support 113. Upon imposition of amplification conditions, a second amplification product 147' is formed comprising a nucleic acid extending from third nucleic acid 127' which is complementary to the first amplification product extending from second nucleic acid 125'. Means for imposing amplification conditions comprise amplification reagents applied through dispensing orifice 174. Amplification reagents comprise buffers, salts, enzymes, nucleotides and the like.

Turning now to Figure 2K, an eleventh work station is depicted for washing the support 113. Stringent washes can be applied to remove unincorporated nucleotides and extraneous matter which may interfere with signal. As illustrated, a wash dispensing orifice 173 applies wash reagents and solutions to the support 113.

A twelfth work station, depicted in Figure 2L, represents a detection step, in the event the method is used for diagnostic or detection purposes rather than for the synthesis of nucleic acid. Detection means 175 detects labelled nucleotides, if such nucleotides are used to form amplification products 145, 145', 147 and 147'. Detection means may comprise photosensors to detect chemiluminescent, luminescent and fluorescent or radioactive labels. Additional reagents to develop the signal are applied to the support 113.

-22-

In the event that the first and second amplification products are made with labeled nucleotides, upon imposition of detection conditions, such as the addition of cofactors or light of a wavelength of which the label is sensitive to, a signal can be developed indicating the presence of the first nucleic acid.

In the alternative, hybridization conditions can be applied to the support in the presence of intercalating agents to develop a signal in the presence of the first and second amplification products.

In addition, a fourth labeled oligonucleotide [not shown] complementary to the first or second amplification product can be used as a probe for detecting the presence of the target first oligonucleotide. A fourth nucleic acid is useful to detect only correct amplification products.

As illustrated, area 121 and 123 have identical second and third nucleic acids 125 and 127 or 125' and 127'. However, support 113 preferably has a plurality of areas which are directed to a plurality of targets. Preferably, at least one area comprises a second and third nucleic acid which have nonsense sequences. This area is intended to not produce a signal as a negative control. The presence of a signal from such second and third nucleic acids defining nonsense sequences indicates a system error.

Preferably, at least one area has a second and third nucleic acid which have sequences which correspond to a first nucleic acid, the presence of which is confirmed as being universally present or which is added to the sample. This area is intended to produce a signal in each instance as a positive control. The absence of a signal indicates a system error.

Turning now to Figure 3, a first nucleic acid generally designated by the numeral 211, is depicted. The first nucleic acid 211 has areas a through f located along its length. The device 213, for mapping regions of a first nucleic acid, has a flat planar surface 215. The surface 215 has areas 217, 219, 221, 223, 225 and 227.

-23-

Each area 217 through 227 has a second nucleic acid 231a-f respectively and a third nucleic acid 233a-f respectively. The second and third nucleic acids 231a-f and 233a-f of each area correspond to an area a-f of nucleic acid 211. Thus, the presence of a particular area on support 215 will depend on the extent in which an area a-f of nucleic acid 211 presents itself. For example, a nucleic acid 211 comprising segments b, c and d, will be detected on areas 219, 221 and 223.

In operation, the device 213 is processed in accordance with the method described with respect to Figures 1a-11. That is, a first nucleic acid 211, or preferably fragments of nucleic acid 211 are applied to one or more devices 213. The devices are monitored to detect the presence of an amplification product in areas 217, 219, 221, 223, 225 and 227. The presence of signal in one area with two different fragments suggests such fragments overlap. The presence of signal on two areas with one fragment suggests such areas are adjacent.

These and other features and advantages of the present invention will be revealed in the following examples which highlight preferred embodiments of the present invention.

EXAMPLES

Example 1 - Formation of an Amplification Product

This example describes a method of making a first amplification product in the presence of a first nucleic acid having a target sequence. The first nucleic acid is a fragment of a larger nucleic acid sonicated to produce an approximate length of 1 kb.

A second nucleic acid is synthesized with a nucleotide sequence complementary to the target sequence of the first nucleic acid and the second nucleic acid is immobilized to an epoxy silane derivatized solid support by a 5' amino group. Spacer groups of hexaethylene-glycol are included during synthesis of the second nucleic acid to eliminate steric hindrance during the hybridization reaction. The spacer region is introduced into the synthesized oligomer prior to amino

-24-

group addition, resulting in a calculated spacer region length of 25 angstroms.

The second nucleic acid is allowed to hybridize with the target DNA sequence of the first nucleic acid in the presence of thermo stable polymerase, enzyme buffer, p32 labeled and unlabeled dNTP to form a reaction mixture. The reaction mixture is heated to 94°C for one minute, for denaturation, cooled to 55°C for one minute, and warmed to 75°C for 5 minutes to form an amplification product extending from the immobilized second nucleic acid and is complementary to the first nucleic acid.

The reaction mixture is washed from the reaction surface and the amplification product detected. Radiolabeled amplification products are detected using photographic film placed with the emulsion in contact with the solid support.

Example 2 - Formation of Cooperating First and Second Amplification Products

This example describes a protocol for forming a first and second amplification product in the presence of a first nucleic acid having a target sequence. The first nucleic acid is derived from genomic DNA which is sonicated to produce fragments of approximately 1 kb in size.

An equimolar distribution of second and third nucleic acids, each complementary to a defined region of the plus and minus ?W? 508 gene sequences are immobilized via 5' ends on a derivatized substrate, e.g. microscope slide, microtitre plates, or glass beads. The fragmented genomic DNA, is allowed to hybridize with the first and second nucleic acid in the presence of thermostable polymerase, enzyme buffer, biotin labeled and unlabeled dNTP to form a reaction mixture. The reaction mixture is heated to 94°C for one minute, for denaturation, cooled to 55°C for one minute, for annealing, and warmed to 75°C for 1 minute, for amplification. After amplification the cycle of heating and cooling continues 30 times to form many first and second amplification products.

-25-

The cycling permits the first and second amplification products to hybridize to adjacent immobilized second and third nucleic acids. Upon imposition of amplification conditions, additional first and second amplification products are formed. The initial target sequence is also available to participate in further hybridization and extension reactions. The cycles may be repeated until all of the immobilized second and third nucleic acids have been extended and labeled with the appropriate nucleotides. The reaction is self-limiting and can be designed to form a predetermined number of amplification products.

The reaction mixture is washed from the reaction surface and the immobilized amplification product detected. To eliminate random background noise the reaction surface is washed using high stringency conditions.

Biotinylated amplification products are detected by analyzing the conversion of a chemiluminescent substrate by a streptavidin-alkaline phosphatase conjugate using x-ray film. Other forms of signal detection can include fluorescence microscopy, fiberoptic devices, confocal microscopy, scintillation detection, piezoelectric material and silicon based systems (charged coupled devices).

Example 3 - Single Polymerase Extension

This example describes a protocol for performing a single hybridization step and polymerase step for the quantification of a first nucleic acid having a target sequence.

A plurality of second nucleic acids, each comprising two or more sequences running in the same direction, complementary to the target sequence, separated by a non-target sequence of a predetermined length are synthesized. The second nucleic acids are immobilized on a support. A sample containing the first nucleic acid is applied to the support to form an immersion product. The immersion product is subjected to denaturation, hybridization and amplification conditions. Under amplification conditions the amplification product is formed which is complementary to the target sequence and the

-26-

non-target sequence simultaneously. Preferably, a single round of annealing and extension will occur. The reaction will be linear and the reaction signal will correspond directly with the number of target sequences.

5 The second nucleic acid can be synthesized with a sequence complementary to any target sequence. Preferably, the probe sequences are separated by 100, 200, 400 or 1000 base pairs and will form a labeled extended strand of the corresponding length. The amplification products can be detected by any
10 suitable means dictated by the type of label used.

Example 4 - Agglutination Assay

This example describes a method of detecting a first nucleic acid, HIV nucleic acid. Second and third nucleic acids of approximately 20 nucleotides in length complementary to an
15 HIV gene sequence are immobilized onto a population of derivatized glass beads. One half of the glass beads contain the second nucleic acid and the other half contains the third nucleic acid. In this example, carboxylated derivatized latex particles may be substituted for the derivatized glass beads.

20 A test sample potentially containing viral nucleic acid is introduced into the reaction chamber vessel containing the glass beads to form a reaction mixture. The reaction mixture is subjected to one or more cycles of heating and cooling.

The viral nucleic acid binds to the second nucleic acid and a first reaction product is formed. This first reaction product extends from the second nucleic acid and is
25 complementary to the third nucleic acid. Hybridization of the first amplification product to the third nucleic acid allows the formation of a second hybridization product and a second amplification product. The second amplification product is
30 complementary to the first amplification product. Upon imposition of hybridization conditions, the beads will agglutinate or precipitate due to the binding of the first and second amplification products. The aggregated or agglutinated
35 complex will be seen spectrophotometrically as a decrease in

-27-

optical density. The turbidity of the reaction solution is a function of assay sensitivity and target specificity.

Example 5 - Quantitative Measurement of Bacteria Nucleic Acid

This example describes a protocol for the quantitative measurement of the amount or quantity of first nucleic acid of bacterial, viral or other origin.

Quantitative measurement of a first nucleic acid can be achieved by the immobilization of varying amounts of a substantially equimolar mixture second nucleic acid and a third nucleic acid in a panel-format. A dipstick device with a series of immobilized second nucleic acid and third nucleic acid, having varying concentrations is used as an assay to quantify bacterial contaminants in food, blood, tissue or other biological matter.

Second and third nucleic acids having a sequence complementary to the first nucleic acids are immobilized on an epoxy silane derivatized dipstick substrate via a 5' amino group. Dipstick substrates can be composed of glass, plastic, or metals. The isolated sections along the derivatized substrate receive an increasing concentration of second and third nucleic acid per unit of surface area.

An aliquot of the test sample is introduced into the reaction mixture containing, reaction buffer, polymerase and biotin labeled nucleic acids. The dipstick is placed in the reaction mixture to form an immersion product. Denaturation, hybridization and amplification conditions are imposed on the immersion product.

After a predetermined number of cycles the dipstick is removed from the reaction mixture and washed. The dipstick is then placed in a second reaction mixture comprising an avidin peroxidase conjugate and incubated for 5 minutes. The dipstick is removed from the second reaction mixture and washed. The dipstick is then placed in a developing mixture comprising a chromogenic substrate specific for peroxidase and allowed to react for 5 minutes. The dipstick is removed from the

-28-

developing mixture, and monitored for color change. The fixed series of second nucleic acid concentrations in distinct areas along the dipstick and the amount of color change in each area becomes a function of the amount of bacterial cells in the test sample. For example, a test sample containing 100 bacteria is expected, after 20 reaction cycles, to cause a vivid color to occur in the dipstick sections containing 103 and 104 second nucleic acid molecules per mm².

Example 6 - Mapping

This example features a protocol for mapping a first nucleic acid. A planar derivatized glass substrate receives sets of second nucleic acids. Each second nucleic acid has approximately 20 nucleotides. Each set of second nucleic acids is complementary to a different sequence corresponding to STS markers along a region of the first nucleic acid. Each set is positioned in a predetermined area of the glass support. Each set is comprised of approximately 100,000 5' amino linked second nucleic acid.

A yeast artificial chromosome (YAC) library containing first nucleic acid is divided into pools for screening. The contents of each YAC pool is applied to the support having the second nucleic acid probe array along with a reaction mixture of polymerase, buffer, and fluorescein labeled deoxy tri-nucleotides. The reaction proceeds for 30 cycles of denaturation, hybridization and amplification. Upon completion of the reaction cycles the support is washed to remove unincorporated nucleotides and YACs.

The support is monitored by detecting the presence of amplification products that correspond to a particular YAC pool. Amplification products formed in the presence of a YAC pool in two arrays suggest that the YAC pool contains an adjacent sequence. An amplification product formed by two different YACs, suggest that the two different YACs have an overlapping sequence.

Example 7

-29-

This Example highlights the formation of an amplification product on silica microspheres. Rather than forming interlinking beads or microspheres, the amplifier product forms a product on each sphere analogous to the process of Fig. 2.

As used herein "(4-OmeT)₈" indicates an 8 nucleotide stretch containing 4-O-methyl-thymine bases. "5'-NH₂-(C6-linker)" indicates that the primers carry a primary amine group linked by a six carbon chain at their 5' ends.

Bglo-(-)

5'-NH₂-(C6-linker)-(4-OmeT)₈-GAAGAGCCAAGGACAGGTAC-3' (Seq. I.D. No. 2)

Bglo-(+)

5'-NH₂-(C6-linker)-(4-OmeT)₈-CCACCTCATCCACGTTCCACC-3' (Seq. I.D. No. 3)

D-13-R

5'-NH₂-(C6-linker)-CTGACCTTAAGTTGTTCTTCCAAAGCAG-3' (Seq. I.D. No. 4)

The initial target used for the Bridge amplification reaction shown in the example was a 268 base pair double-stranded PCR product that was purified from a solution phase amplification reaction. The solution phase reaction used the Bglo-(+) and Bglo-(-) primers and a human genomic DNA sample. The specific target fragment used in the example was not sequenced, but it can be assumed to be virtually identical to other previously sequenced human beta-globin genes.

The target sequence shown below in Table 1 and Seq. I.D. No. 1 was deduced from GenBank sequence Accession #26462, using the sequence of the Bglo-(+) and Bglo-(-) primers above. The target region overlaps the 5'-end of the coding sequence of the human beta-globin gene. The ATG initiation codon of exon 1 is underlined. The strand with the same sequence as the mRNA is shown.

TABLE 1

5'-GAAGAGCCAA GGACAGGTAC GGCTGTCATC ACTTAGACCT CACCCTGTGG
AGCCACACCC TAGGGTTGGC CAATCTACTC CCAGGAGCAG GGAGGGCAGG
AGCCAGGGCT GGGCATAAAA GTCAGGGCAG AGCCATCTAT TGCTTACATT

-30-

TGCTTCTGAC ACAACTGTGT TCACTAGCCA CCTCAAACAG ACACCATGGT
GCATCTGACT CCTGAGGAGA AGTCTGCCGT TACTGCCCTG TGGGGCAAGG
TGAACGTGGA TGAAGTTG-3'

5 Solid silica microspheres (0.4 micron diameter) were
purchased commercialy (Bangs Laboratories, Carmel, Indiana,
USA). A surface epoxide layer was deposited on the
microspheres using the method of Chang, Gooding and Regnier,
1976, J. Chromat. 120, 321-333, as described below. A 10%
10 aqueous solution of 3-glycidoxypropyltrimethoxysilane (3-GPTS)
was prepared and adjusted to pH 5.7 with 1 millimolar potassium
hydroxide, 0.5 milliliters of the 10% 3-GPTS solution were
mixed with 100 milligrams of the microspheres suspended in 0.5
milliliters of deionized water. The mixture was held at 88 to
15 90°C for 30 minutes. The tube was mixed briefly on a vortex
mixer at 5 minute intervals during the incubation. After
heating, the beads were washed twice by centrifugation and
resuspension in deionized water (1.5 milliliters per wash, 2000
x g, 2 minutes).

20 Epoxide-silica microspheres (50 mg) were washed once in
1.5 milliliters of 0.1 molar potassium hydroxide. The
microspheres were centrifuged as described above and
resuspended in 75 microliters of 0.1 molar potassium hydroxide
containing Bglo-(+) and Bglo-(-) primers each at 29 micromolar
25 concentration, Oligonucleotide D-13-R, 3'-end-labeled with
ddATP-alpha-³⁵S and terminal transferase, was included at a
concentration of 0.2 nanomolar as a tracer to monitor the level
of oligonucleotide binding. The derivization was carried out
for 8 hours at 37°C, with intermittent vortex mixing to
30 resuspend the microspheres. The microspheres were washed three
times by centrifugation and resuspended in 0.1 M potassium
hydroxide and twice in deionized water (0.5 milliliters per
wash). The microspheres were then resuspended in 200
microliters of 20% ethanolamine (w/v), pH 8.2, and incubated
35 for 8 hours at 37°C with intermittent mixing. The microspheres
were then washed three times by centrifugation and resuspension

-31-

in an aqueous solution of 0.5% Tween-20 (v/v), 100 micrograms/milliliter bovine serum albumin, (0.5 milliliters/wash). From the level of bound ³⁵S-labeled-D-13-R primer, the estimated total primer concentration (equimolar (+) and (-) primer) on the microspheres was 2.1 - 2.2 picomoles per milligram of microspheres.

Primers carrying 5' amino linkers were reacted with the epoxy beads for 12 hours in 0.1 N KOH, at 37°C. The primers used in this experiment amplify a 268 bp target from the human beta-globin gene. Unreacted epoxide groups were eliminated by treating the beads with 2M ethanolamine, pH 8.0, for an additional 12 hours at 37°C.

Using the simplifying assumption that the oligonucleotides bind in a square array on the surface, the spacing between adjacent primers is estimated to be 767 angstroms. This distance is equivalent to the length of a 225 bp fragment of double-stranded DNA.

A 2 mg amount of primer-modified beads was cycled in 100 ul reactions containing: 10mM Tris HCl (pH 8.3 at 25°C), 100 ug/ml BSA, 0.5% Tween 20, 5 U Tth polymerase, 200 uM each dNTP, and 0.25 uM dCTP-alpha-³²P (800 Ci/mmol). The initial target used was 0.45 pmole of the 268 bp beta-globin PCR product, purified from a solution phase PCR reaction by Centricon-100 ultrafiltration. Cycling was carried out for 35 cycles using 1 minute at 94°C, followed by 5 minutes at 60°C.

At each time point, aliquots containing 0.35 mg of the beads were removed and washed on 0.2 micron centrifugal filters with 10 mM Tris HCl, pH 7.6, 1 mM EDTA, 0.5% Tween 20. Bead-bound radioactivity on the filters was determined by Cerenkov counting. The bound radioactivity cannot be removed by washing at 94°C suggesting that the measured radioactivity is covalently bound to the surface, and not merely adsorbed or hybridized to the primers.

The data suggest target-and-primer-dependent incorporation of radioactive dCTP into bead-bound form. These data are described in Figure 4 as counts per minute. As used in

-32-

Figure 4, open circles and triangles represent reactions of beads carrying the (+) and (-) primers and reactions in the presence of target. Closed circles represent a reaction of beads carrying the (+) and (-) primers in the absence of target. Closed squares represent beads without the (+) and (-) primers in the presence of target, and closed triangles represented beads without the (+) and (-) primers in the absence of target. No incorporation signal is obtained from primer-modified beads in the absence of target (closed circles), or unmodified beads in the presence or absence of target (closed squares and closed triangles respectively). These results suggest that incorporation is due to specific primer-mediated polymerase extension on the added target molecules.

In the reactions involving beads with the (+) and (-) primer in the presence of target, incorporation increases 6.5-fold for the 5 cycles following cycle 20. This rate is greater than that expected for primer extension using only solution phase target as template, which would be expected to increase by 5-fold at most. This suggests that amplification is taking place on the surface of the beads. Assuming an exponential amplification reaction, the increase in incorporation per cycle is approximately 1.4-fold for cycles 21-25.

To verify that the bead-bound product has the predicted bridge structure, primers directed toward a human dystrophin gene fragment were modified to include restriction enzyme sites. The (+) primer contains an XbaI site and the (-) primer contains a ClaI site.

After amplification, two kinds of bead-bound products are expected. Products formed by interaction between solution phase target and primers will generate simple extension products bound only by a single end. These primary extension products can be released by cleavage with a single enzyme, either XbaI or ClaI depending on the primer extended. In contrast, bridge amplification products are bound by both ends,

-33-

and therefore can only be released by cleavage with both enzymes.

Amplifications were carried out with epoxy-silica beads modified with the dystrophin primers, using the purified 545 bp dystrophin PCR product as target. After 35 cycles, the beads were washed to remove unbound radioactivity, and split into four equal portions. One portion was left in restriction buffer without enzyme, two portions were singly digested with ClaI or XbaI, and one portion was digested simultaneously with both enzymes. After digestion the beads were pelleted by centrifugation, and the supernatants were analyzed by acrylamide gel electrophoresis and autoradiography.

A prominent 545 bp product was clearly visible in the lanes from target-containing reactions, but not in target-(-) controls.

Single enzyme cleavage with either enzyme releases a small amount of primary extension product as predicted by Figure 3, and a larger amount is released by double digestion. Densitometric analysis of the bead-bound samples are shown in the lower portion of Figure 4. The combined integration volume from the two single digests is 1.25 (0.86 "C" + 0.39 "X"), while the integration volume from the double digest is approximately 2.7 times greater. These data suggest that 72% of the products found on the beads are in the bridged conformation.

These data suggest the rate of incorporation is consistent with an exponential process; incorporation increases approximately 1.4-fold per cycle. The predicted specific amplification target is produced in bead-bound form, and most of the bound product is attached in the bridge conformation.

Thus, while preferred embodiments have been illustrated and described, it is understood that the present invention is capable of variation and modification and, therefore, should not be limited to the precise details set forth, but should also include such changes and alterations that fall within the purview of the following claims.

-34-

SEQUENCE LISTING

(1) GENERAL INFORMATION:

(i) APPLICANT:

(A) NAME: MOSAIC TECHNOLOGIES, INC.
(B) STREET: 255 BROADWAY
(C) CITY: WINTER HILL
(D) STATE: MASSACHUSETTS
(E) COUNTRY: UNITED STATES
(F) POSTAL CODE: 02145
(G) TELEPHONE: 617-625-3583

(i) APPLICANT:

(A) NAME: WHITEHEAD INSTITUTE FOR BIOMEDICAL
RESEARCH
(B) STREET: 9 CAMBRIDGE CENTER
(C) CITY: CAMBRIDGE
(D) STATE: MASSACHUSETTS
(E) COUNTRY: UNITED STATES
(F) POSTAL CODE: 02142
(G) TELEPHONE: 617-258-5000

(i) APPLICANT/INVENTOR:

(A) NAME: ADAMS, CHRISTOPHER P.
(B) STREET: 255 BROADWAY
(C) CITY: WINTER HILL
(D) STATE: MASSACHUSETTS
(E) COUNTRY: UNITED STATES
(F) POSTAL CODE: 02145
(G) TELEPHONE: 617-625-3583

(i) APPLICANT/INVENTOR:

(A) NAME: KRON, STEPHEN JOSEPH
(B) STREET: 427 MARLBORO STREET
(C) CITY: BOSTON
(D) STATE: MASSACHUSETTS
(E) COUNTRY: UNITED STATES
(F) POSTAL CODE: 02115
(G) TELEPHONE:

(ii) TITLE OF INVENTION: METHOD AND APPARATUS FOR
PERFORMING AMPLIFICATION OF NUCLEIC ACIDS ON SUPPORTS

(iii) NUMBER OF SEQUENCES: 4

(iv) CORRESPONDENCE ADDRESS:

(A) ADDRESSEE: WOLF, GREENFIELD & SACKS, P.C.
(B) STREET: 600 ATLANTIC AVENUE
(C) CITY: BOSTON
(D) STATE: MASSACHUSETTS
(E) COUNTRY: USA

-35-

(F) ZIP: 02210

(v) COMPUTER READABLE FORM:

- (A) MEDIUM TYPE: Floppy disk
- (B) COMPUTER: IBM PC compatible
- (C) OPERATING SYSTEM: PC-DOS/MS-DOS
- (D) SOFTWARE: PatentIn Release #1.0, Version #1.25

(vi) CURRENT APPLICATION DATA:

- (A) APPLICATION NUMBER: NOT AVAILABLE
- (B) FILING DATE: FILED HEREWITH

(vii) PRIOR APPLICATION DATA:

- (A) APPLICATION NUMBER: US 08/285,385
- (B) FILING DATE: 03-AUGUST-1994

(viii) ATTORNEY/AGENT INFORMATION:

- (A) NAME: JANIUK, ANTHONY J.
- (B) REGISTRATION NUMBER: 29,809
- (C) REFERENCE/DOCKET NUMBER: B0833/7001WO

(ix) TELECOMMUNICATION INFORMATION:

- (A) TELEPHONE: 617-720-3500
- (B) TELEFAX: 617-720-2441

(2) INFORMATION FOR SEQ ID NO:1:

(i) SEQUENCE CHARACTERISTICS:

- (A) LENGTH: 268 base pairs
- (B) TYPE: nucleic acid
- (C) STRANDEDNESS: double
- (D) TOPOLOGY: linear

(ii) MOLECULE TYPE: DNA (genomic)

(iii) HYPOTHETICAL: NO

(iv) ANTI-SENSE: NO

(vi) ORIGINAL SOURCE:

- (A) ORGANISM: Homo sapiens

(xi) SEQUENCE DESCRIPTION: SEQ ID NO:1:

GAAGAGCCAA GGACAGGTAC GGCTGTCATC ACTTAGACCT CACCCTGTGG
AGCCACACCC 60

TAGGGTTGGC CAATCTACTC CCAGGAGCAG GGAGGGCAGG AGCCAGGGCT
GGGCATAAAA 120

GTCAGGGCAG AGCCATCTAT TGCTTACATT TGCTTCTGAC ACAACTGTGT
TCACTAGCAA 180

-36-

CCTCAAACAG ACACCATGGT GCATCTGACT CCTGAGGAGA AGTCTGCCGT
TACTGCCCTG 240

TGGGGCAAGG TGAACGTGGA TGAAGTTG

268

(2) INFORMATION FOR SEQ ID NO:2:

- (i) SEQUENCE CHARACTERISTICS:
 - (A) LENGTH: 28 base pairs
 - (B) TYPE: nucleic acid
 - (C) STRANDEDNESS: single
 - (D) TOPOLOGY: linear
- (ii) MOLECULE TYPE: DNA (genomic)
- (iii) HYPOTHETICAL: NO
- (iv) ANTI-SENSE: NO
- (vi) ORIGINAL SOURCE:
 - (A) ORGANISM: Homo sapiens
- (ix) FEATURE:
 - (A) NAME/KEY: modified_base
 - (B) LOCATION: 1..8
 - (D) OTHER INFORMATION: /mod_base= OTHER
/note= "N represents 4-O-methyl-thymine"
- (xi) SEQUENCE DESCRIPTION: SEQ ID NO:2:

NNNNNNNNGA AGAGCCAAGG ACAGGTAC

28

(2) INFORMATION FOR SEQ ID NO:3:

- (i) SEQUENCE CHARACTERISTICS:
 - (A) LENGTH: 28 base pairs
 - (B) TYPE: nucleic acid
 - (C) STRANDEDNESS: single
 - (D) TOPOLOGY: linear
- (ii) MOLECULE TYPE: DNA (genomic)
- (iii) HYPOTHETICAL: NO
- (iv) ANTI-SENSE: NO
- (vi) ORIGINAL SOURCE:
 - (A) ORGANISM: Homo sapiens

-37-

(ix) FEATURE:

- (A) NAME/KEY: modified_base
- (B) LOCATION: 1..8
- (D) OTHER INFORMATION: /mod_base= OTHER
/note= "N represents 4-O-methyl-thymine"

(xi) SEQUENCE DESCRIPTION: SEQ ID NO:3:

NNNNNNNNCC ACCTCATCCA CGTTCACC

28

(2) INFORMATION FOR SEQ ID NO:4:

(i) SEQUENCE CHARACTERISTICS:

- (A) LENGTH: 28 base pairs
- (B) TYPE: nucleic acid
- (C) STRANDEDNESS: single
- (D) TOPOLOGY: linear

(ii) MOLECULE TYPE: DNA (genomic)

(xi) SEQUENCE DESCRIPTION: SEQ ID NO:4:

CTGACCTTAA GTTGTTCTTC CAAAGCAG

28

-38-

CLAIMS

1. A method of forming an amplification product in the presence of a first nucleic acid in a sample, which first nucleic acid has a target sequence, comprising:

5 (a) forming an immersion product, said immersion product comprising said sample and a second nucleic acid, said second nucleic acid having a sequence complementary to said target sequence and said second nucleic acid covalently linked to a support;

10 (b) forming a hybridization product comprising said first nucleic acid and said second nucleic acid, in the event said first nucleic acid is present, by imposing hybridization conditions on the immersion product; and

15 (c) forming an amplification product comprising said second nucleic acid extended by nucleotides complementary to said first nucleic acid, in the event that said first nucleic acid is present, to form nucleic acid covalently affixed to said support.

20 2. The method of claim 1 further comprising the steps of monitoring the support for the presence of said amplification product which amplification product is indicative of the presence of the target and which absence is indicative of the absence of the target.

25 3. The method of claim 1 wherein said support is an epoxy silane derivatized support.

4. The method of claim 1 wherein said second nucleic acid has a 5' amino group which 5' amino group is covalently bonded to hexaethylene glycol functional group covalently bonded to said support.

30 5. The method of claim 1 wherein the first nucleic acid has a size of approximately one to ten kilobases.

35 6. The method of claim 1 wherein the amplification product is formed by imposing amplification conditions on said immersion product which amplification conditions comprise applying a thermostable polymerase to said hybridization product.

-39-

7. The method of claim 1 wherein the amplification product has a label for detection.

8. The method of claim 7 wherein the nucleotides are radiolabeled.

5 9. The method of claim 7 wherein the nucleotides are labeled with one or more of the group selected from chemiluminescence, radioactive, luminescent, and fluorescent agents.

10. The method of claim 1 wherein said method further comprises the step of releasing said first nucleic acid from said second nucleic acid by imposing denaturation conditions on said immersion product.

11. The method of claim 10 further comprising the step of forming a second hybridization product, said second hybridization product comprising said first amplification product and a third nucleic acid, said third nucleic acid covalently affixed to said support and having a nucleotide sequence complementary to said first amplification product, and upon imposing hybridization condition on the immersion product, said third nucleic acid forming a second hybridization product with said first amplification product.

12. The method of claim 10 further comprising the additional step of forming a second amplification product comprising a nucleic acid extending from said third nucleic acid complementary to said first amplification product.

13. The method of claim 12, said method further the step of detecting at least one amplification product.

14. The method of claim 1 wherein said second nucleic acid has a position on said support and said third nucleic acid has a position on said support, said positions are spaced a distance less than the length of said first nucleic acid to allow an amplification product to form between said second and third nucleic acids.

15. The method of claim 10 wherein said immersion product comprises a second support having a third nucleic acid and third nucleic acid complementary to said first amplification

product, said method further comprising forming a second hybridization product comprising said third nucleic acid and said first amplification product.

5 16. The method of claim 15 wherein said second hybridization product promotes agglutination or precipitation of said immersion product.

10 17. The method of claim 15 further comprising forming a second amplification product comprising a nucleic acid extending from said third nucleic acid complementary to said first amplification product.

18. The method of claim 17 wherein said second amplification product promotes agglutination or precipitation of said immersion product.

15 19. The method of claim 18 wherein said support for said second nucleic acid and said support for said third nucleic acid comprises glass beads or carboxylated latex particles.

20 20. The method of claim 11 wherein said first and second amplification products are made simultaneously.

20 21. The method of claim 11 wherein the amount of amplification product formed is monitored to indicate the amount of target present.

25 22. The method of claim 10 wherein said first nucleic acid is part of a large nucleic acid, and said second and third nucleic acid are a set for detecting said first nucleic acid, said method comprising a plurality of sets each for a first nucleic acid of said large nucleic acid, said sets detecting respective first nucleic acid suggesting overlapping sequences, said set detecting multiple first nucleic acids suggesting adjacent sequences.

30 23. The method of claim 23 further comprising the step of assembling the overlapping all adjacent sequences to map such sequences on said large nucleic acid.

35 24. An article of manufacture for forming an amplification product in the presence of a first nucleic acid having a target sequence which first nucleic acid is potentially in a sample, comprising:

-41-

a support having a second nucleic acid having a nucleotide sequence complementary to said target sequence, which second nucleic acid is covalently bound to said support; said support for forming an immersion product with one or more samples potentially containing said first nucleic acid, and undergoing hybridization conditions and amplification conditions to form a first hybridization product and a first amplification product in the presence of said first nucleic acid, said first amplification product extending from said second nucleic acid and complementary to said first nucleic acid.

25. The article of manufacture of claim 24 wherein said support further comprises a third nucleic acid, said third nucleic acid complementary to said first amplification product for forming a second hybridization product upon imposition of hybridization conditions.

26. The article of manufacture of claim 25 wherein said third nucleic acid primes a reaction to form a second amplification product.

27. The article of manufacture of claim 25 wherein said second and third nucleic acid have spaced positions on said support, said positions separated by a distance less than the length of said first nucleic acid.

28. The article of manufacture of claim 25 wherein said first nucleic acid is part of a large nucleic acid comprising a plurality of first nucleic acids, said support has a first set of second and third nucleic acids corresponding to one of said first nucleic acid, and at least one second set of said second and third nucleic acids corresponding to a second first nucleic acid, to allow mapping of said large nucleic acid.

29. An instrument for forming an amplification product in the presence of a first nucleic acid having a target sequence comprising

(a) means for receiving a support having a second nucleic acid having a nucleotide sequence complementary to said target sequence, which second nucleic acid is covalently bound

to said support; said support for forming an immersion product with samples potentially containing said first nucleic acid, undergoing hybridization conditions and amplification conditions to form a first hybridization product and a first
5 amplification product in the presence of said first nucleic acid, said first amplification product extending from said second nucleic acid and complementary to said first nucleic acid.

(b) means for imposing hybridization conditions on
10 said support for forming a hybridization product in the presence of said first nucleic acid; and

(c) means for imposing amplification conditions on said hybridization product, if formed, to form an amplification product.

15 30. The instrument of claim 29 wherein said support has a third nucleic acid which third nucleic acid is capable of forming a hybridization product with said first amplification product, and capable of promoting a second amplification product upon imposition of amplification conditions.

20 31. The instrument of claim 30 wherein said first nucleic acid is part of a large nucleic acid, said second and third nucleic acid comprise a set and said support has a plurality of sets, each set having a position separate from other sets, which position cooperates with alignment means on said support.

25 32. The instrument of claim 31 further comprising alignment sensing means for receiving alignment means on said support.

Fig. 1A

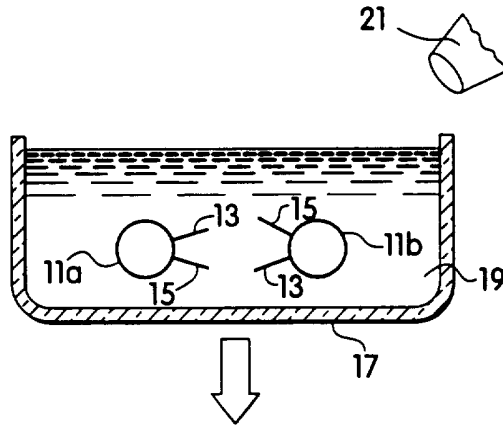

Fig. 1B

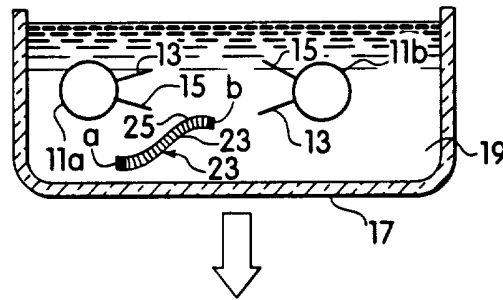

Fig. 1C

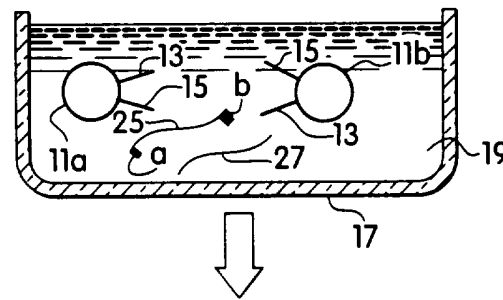

Fig. 1D

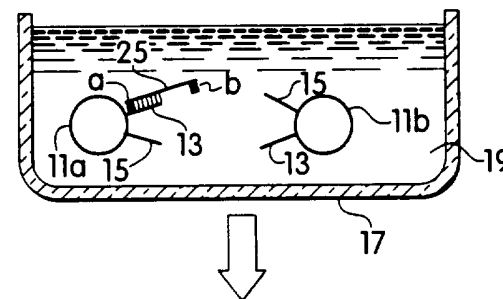

Fig. 1E

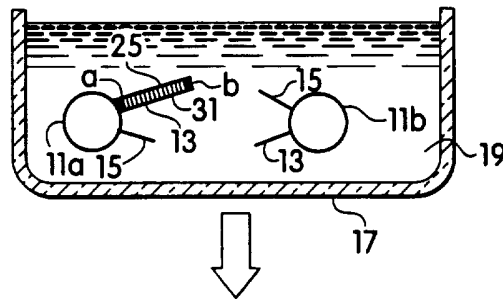

Fig. 1F

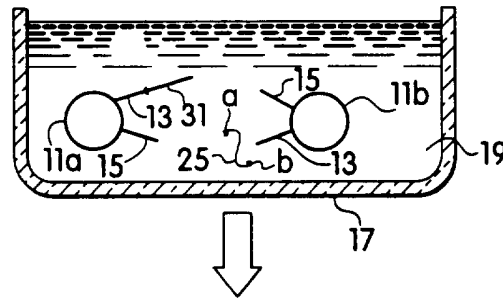

Fig. 1G

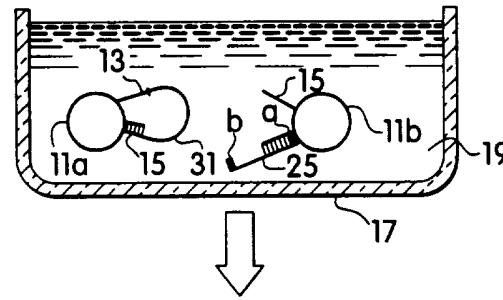

Fig. 1H

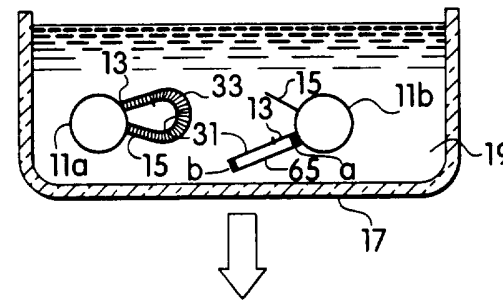

Fig. 1I

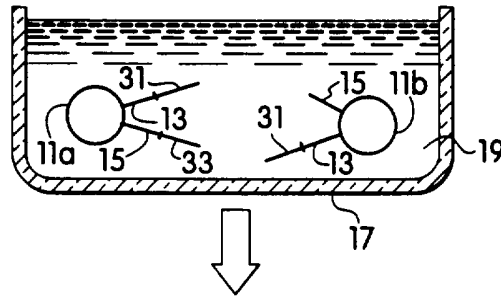

Fig. 1J

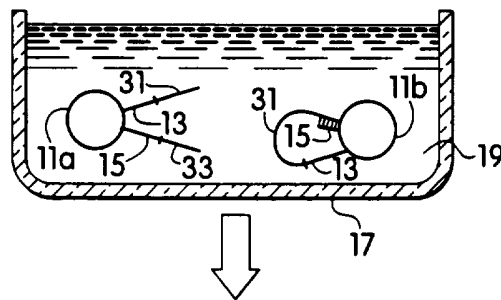

Fig. 1K

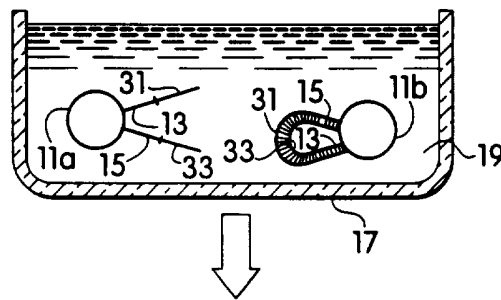

Fig. 1L

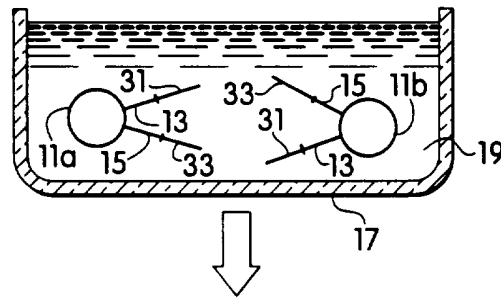

Fig. 1M

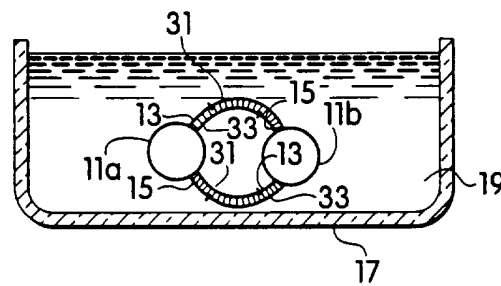

Fig. 2A

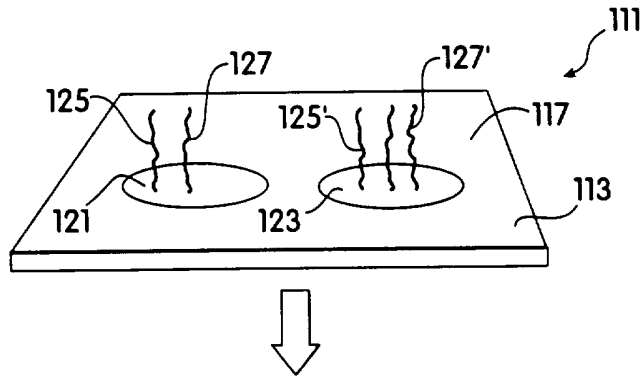

Fig. 2B

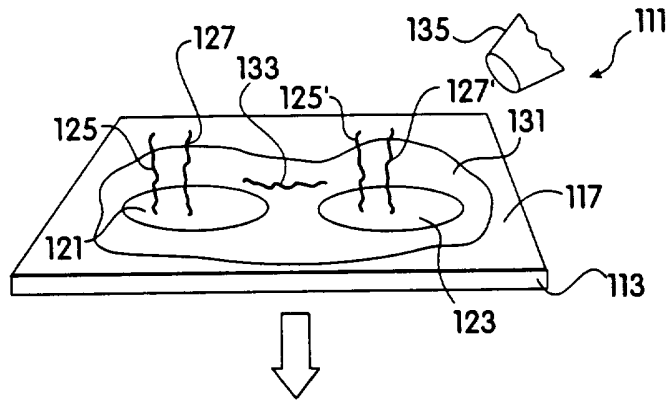

Fig. 2C

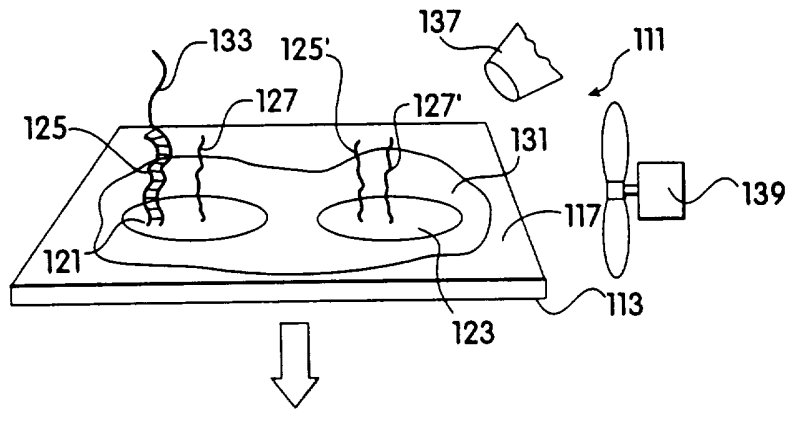

Fig. 2D

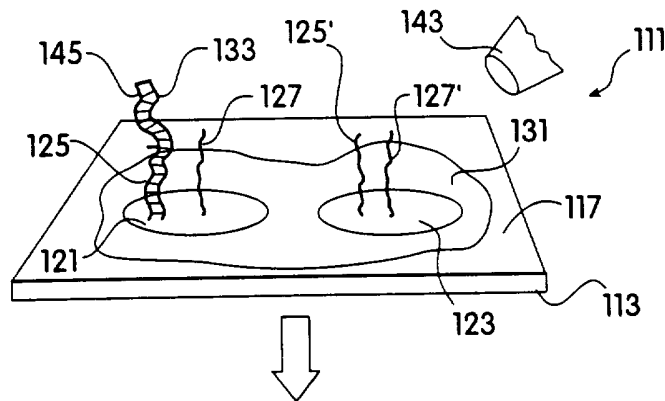

Fig. 2E

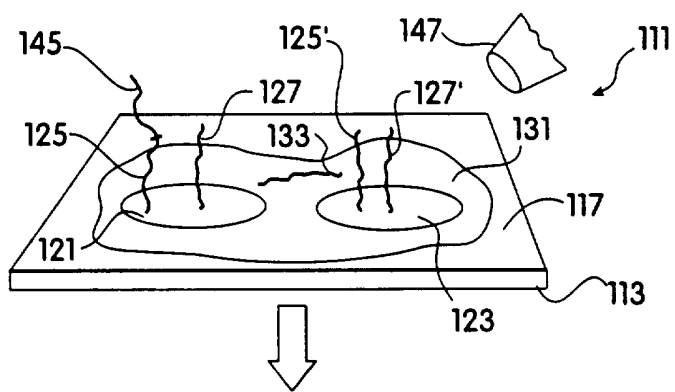

Fig. 2F

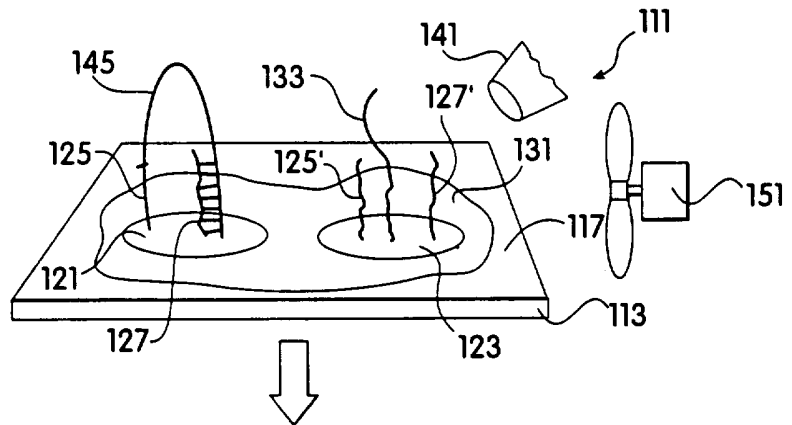

Fig. 2G

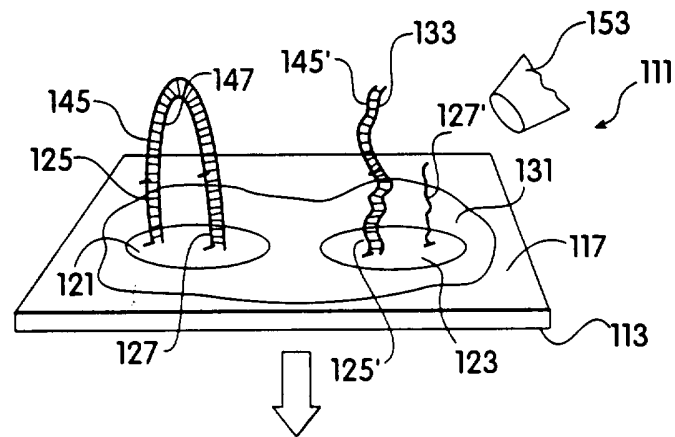
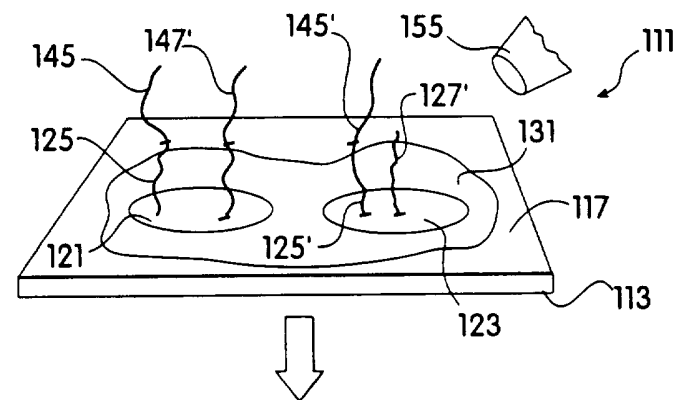

Fig. 2H



6/8

Fig. 2I

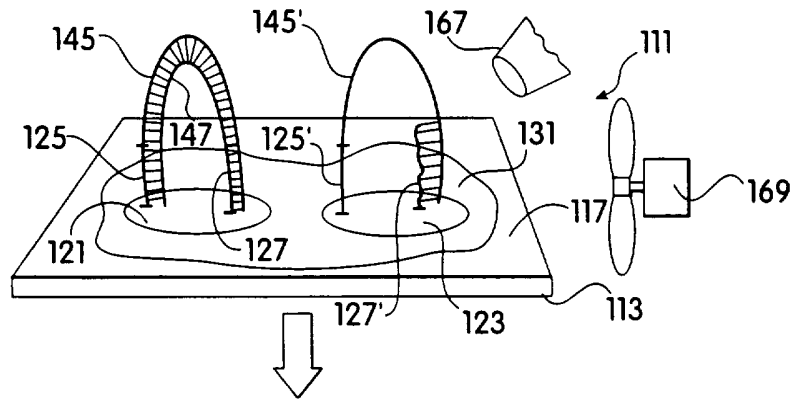

Fig. 2J

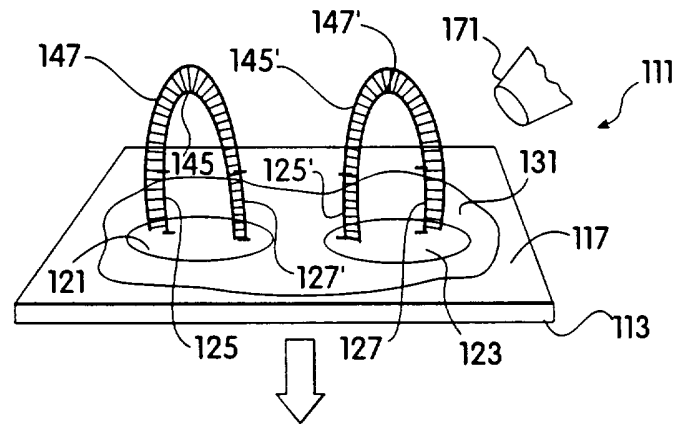

Fig. 2K

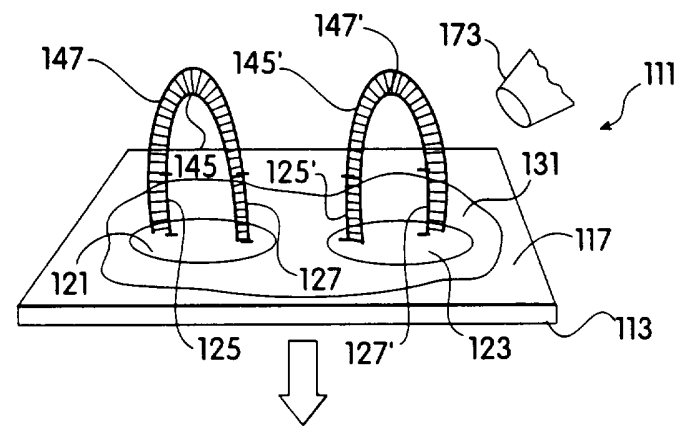
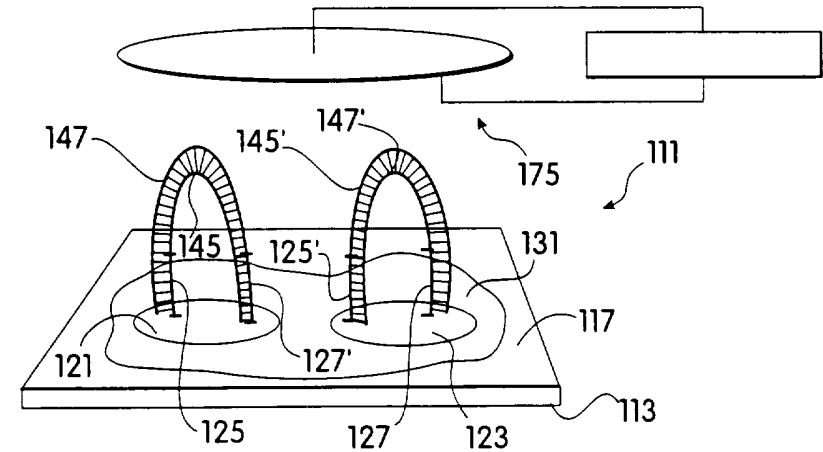

Fig. 2L



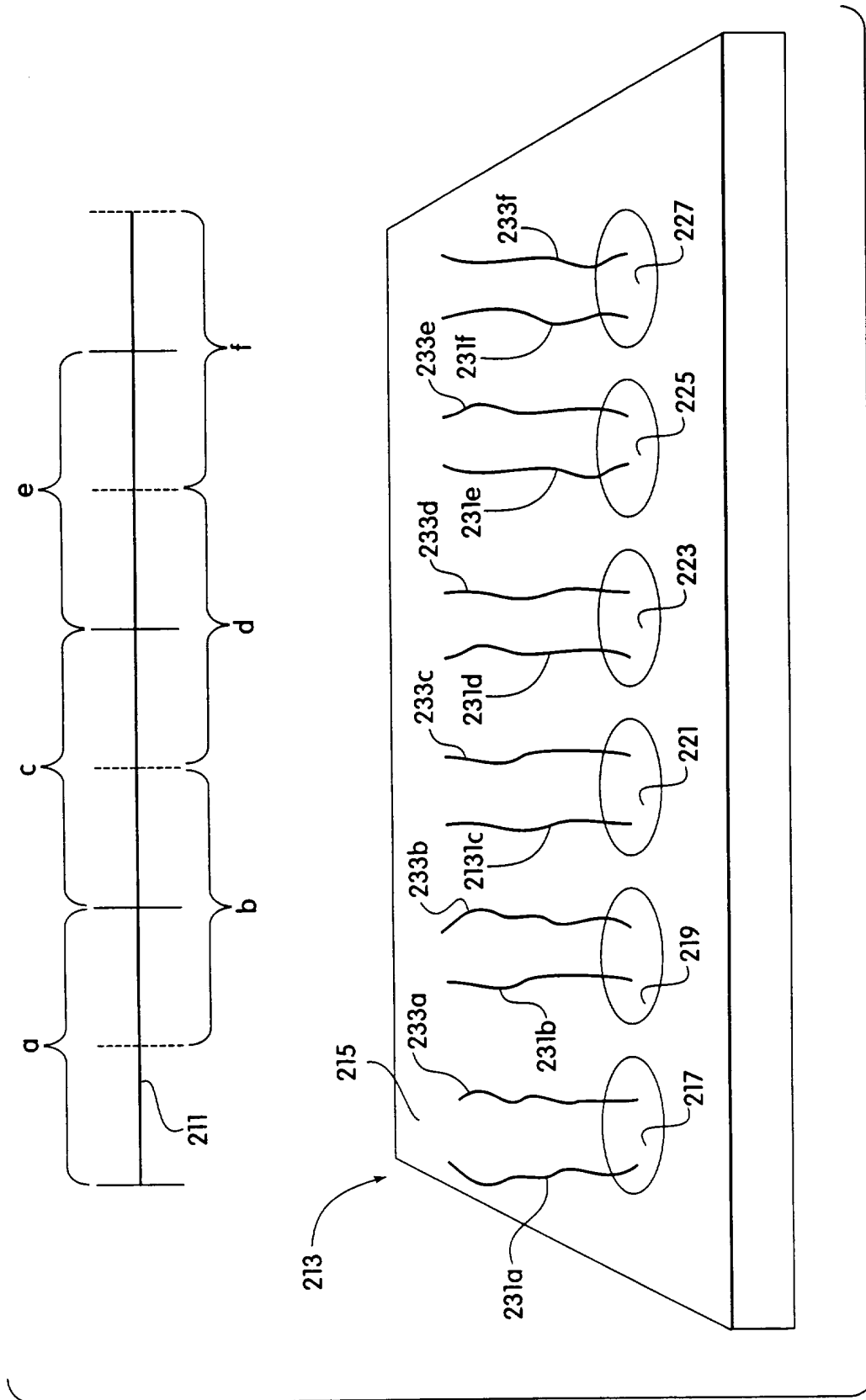

Fig. 3

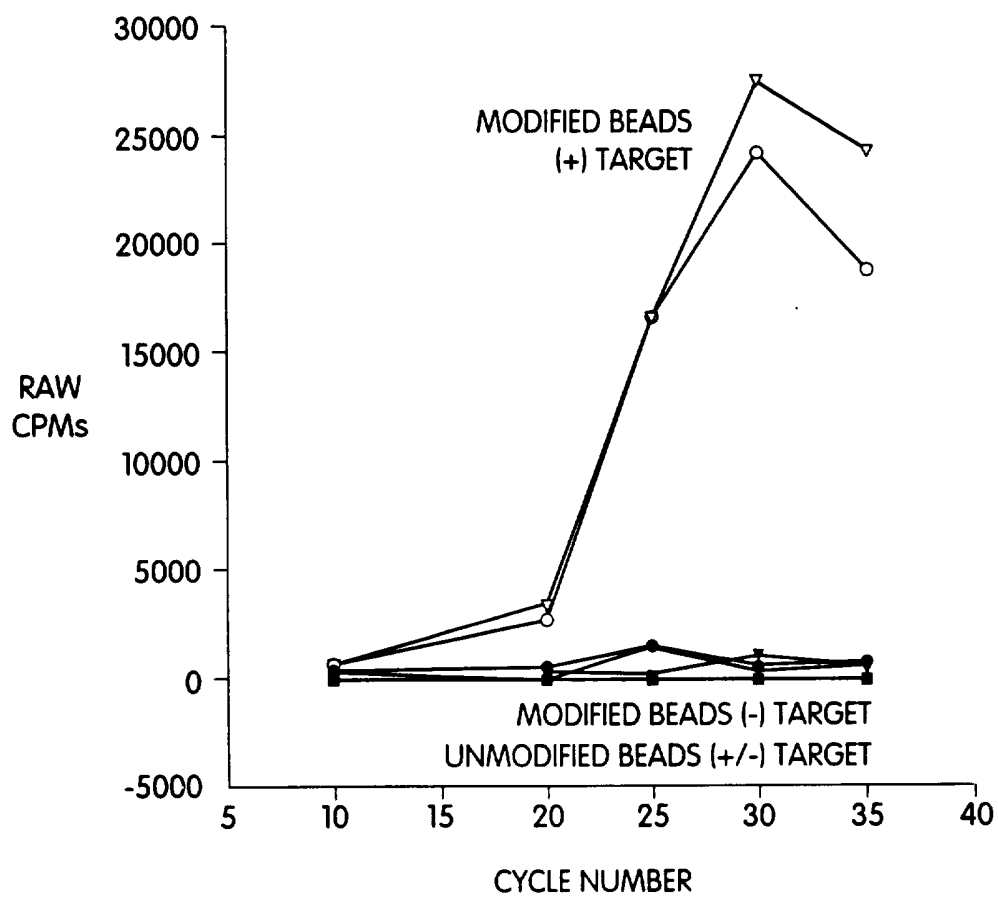

Fig. 4

INTERNATIONAL SEARCH REPORT

International Application No
PCT/US 95/09905

A. CLASSIFICATION OF SUBJECT MATTER
IPC 6 C12Q1/68

According to International Patent Classification (IPC) or to both national classification and IPC

B. FIELDS SEARCHED

Minimum documentation searched (classification system followed by classification symbols)

IPC 6 C12Q

Documentation searched other than minimum documentation to the extent that such documents are included in the fields searched

Electronic data base consulted during the international search (name of data base and, where practical, search terms used)

C. DOCUMENTS CONSIDERED TO BE RELEVANT

Category *	Citation of document, with indication, where appropriate, of the relevant passages	Relevant to claim No.
X	WO,A,93 09250 (ADELAIDE CHILDRENS HOSPITAL) 13 May 1993 specially see figure 4 see the whole document ---	1-10, 24, 29
X	WO,A,93 04199 (SCIENTIFIC GENERICS LTD.) 4 March 1993 see the whole document ---	1-10, 24, 29
X	EP,A,0 374 665 (MOLECULAR DIAGNOSTICS) 27 June 1990 see the whole document ---	1-10, 24, 29
X	WO,A,90 09455 (GENECOPTY) 23 August 1990 see the whole document ---	1-10, 24, 29
	-/--	

Further documents are listed in the continuation of box C.

Patent family members are listed in annex.

* Special categories of cited documents :

- * "A" document defining the general state of the art which is not considered to be of particular relevance
- * "E" earlier document but published on or after the international filing date
- * "L" document which may throw doubts on priority claim(s) or which is cited to establish the publication date of another citation or other special reason (as specified)
- * "O" document referring to an oral disclosure, use, exhibition or other means
- * "P" document published prior to the international filing date but later than the priority date claimed

- * "T" later document published after the international filing date or priority date and not in conflict with the application but cited to understand the principle or theory underlying the invention
- * "X" document of particular relevance; the claimed invention cannot be considered novel or cannot be considered to involve an inventive step when the document is taken alone
- * "Y" document of particular relevance; the claimed invention cannot be considered to involve an inventive step when the document is combined with one or more other such documents, such combination being obvious to a person skilled in the art.
- * "&" document member of the same patent family

Date of the actual completion of the international search

15 December 1995

Date of mailing of the international search report

05.01.96

Name and mailing address of the ISA
European Patent Office, P.B. 5818 Patentlaan 2
NL - 2280 HV Rijswijk
Tel. (+ 31-70) 340-2040, Tx. 31 651 epo nl,
Fax (+ 31-70) 340-3016

Authorized officer

Molina Galan, E

INTERNATIONAL SEARCH REPORT

information on patent family members

International Application No

PCT/US 95/09905

Patent document cited in search report	Publication date	Patent family member(s)	Publication date
WO-A-9309250	13-05-93	CA-A- 2122450	13-05-93
		EP-A- 0672173	20-09-95
WO-A-9304199	04-03-93	NONE	
EP-A-374665	27-06-90	AU-A- 3716293	01-07-93
		AU-B- 4714489	28-06-90
		CA-A- 2004326	23-06-90
		JP-A- 3043099	25-02-91
WO-A-9009455	23-08-90	AU-B- 656514	09-02-95
		AU-B- 5106990	05-09-90
		EP-A- 0457824	27-11-91
		JP-T- 4503158	11-06-92
WO-A-9006042	14-06-90	AU-B- 640626	02-09-93
		AU-B- 4758690	26-06-90
		AU-B- 634993	11-03-93
		AU-B- 4759690	26-06-90
		DE-D- 68908900	07-10-93
		DE-T- 68908900	20-01-94
		DE-D- 68913555	07-04-94
		DE-T- 68913555	07-07-94
		WO-A- 9006045	14-06-90
		EP-A- 0446260	18-09-91
		EP-A, B 0444120	04-09-91
		JP-T- 4501956	09-04-92
JP-T- 4501959	09-04-92		
EP-A-487104	27-05-92	AU-B- 8801591	28-05-92
		JP-A- 5192196	03-08-93
WO-A-9002205	08-03-90	NONE	
WO-A-9204469	19-03-92	AU-B- 8505091	30-03-92

INTERNATIONAL SEARCH REPORT

Internal Application No
PCT/US 95/09905

C.(Continuation) DOCUMENTS CONSIDERED TO BE RELEVANT

Category *	Citation of document, with indication, where appropriate, of the relevant passages	Relevant to claim No.
X	WO,A,90 06042 (DYNAL) 14 June 1990 see the whole document ---	1-10,24, 29
A	EP,A,0 487 104 (SUMITOMO) 27 May 1992 see the whole document ---	3,4
A	WO,A,90 02205 (ANGENICS) 8 March 1990 see the whole document ---	16
A	WO,A,92 04469 (ICI) 19 March 1992 see the whole document -----	16