

(19)



(11)

EP 1 625 922 B1

(12)

EUROPEAN PATENT SPECIFICATION

(45) Date of publication and mention of the grant of the patent:
15.10.2008 Bulletin 2008/42

(51) Int Cl.:
B28B 7/00 (2006.01) F26B 25/18 (2006.01)

(21) Application number: **05076790.4**

(22) Date of filing: **02.08.2005**

(54) **Supporting element**

Trägerelement

Elément de support

(84) Designated Contracting States:
AT BE BG CH CY CZ DE DK EE ES FI FR GB GR HU IE IS IT LI LT LU LV MC NL PL PT RO SE SI SK TR

(30) Priority: **10.08.2004 NL 1026812**

(43) Date of publication of application:
15.02.2006 Bulletin 2006/07

(73) Proprietor: **Stafier Holland B.V. 6942 PX Didam (NL)**

(72) Inventor: **Holtendorp, Petrus Theodorus Albertus 6942 AS Didam (NL)**

(74) Representative: **Van kan, Johan Joseph Hubert et al Algemeen Octrooi- en Merkenbureau P.O. Box 645 5600 AP Eindhoven (NL)**

(56) References cited:
BE-A- 558 649 DE-A1- 3 538 096 DE-U1- 29 705 369 FR-A- 2 725 588

EP 1 625 922 B1

Note: Within nine months of the publication of the mention of the grant of the European patent in the European Patent Bulletin, any person may give notice to the European Patent Office of opposition to that patent, in accordance with the Implementing Regulations. Notice of opposition shall not be deemed to have been filed until the opposition fee has been paid. (Art. 99(1) European Patent Convention).

Description

[0001] The present invention relates to a supporting element for bricks that are dried while being supported thereon, comprising a plate with downwardly extending plate edges, between which plate edges a stiffening section extends, which stiffening section is connected to the plate at spaced-apart points of attachment on the bottom side of the plate.

[0002] Such a plate is generally known, it is used in the brick industry for placing green bricks of clay or loam thereon. Usually, the stiffening section is spot-welded to the plate. The plate supporting the green bricks is subsequently taken to a drying space for drying the clay or loam. Then the plates with the green bricks of clay or loam are taken to a kiln, where they are baked into bricks. A major problem that occurs with the supporting elements that are currently being used is that the plate and the stiffening section vibrate against one another during handling and transport, which causes noise nuisance. Especially when large numbers of plates are being handled and transported, as is the case in the brick industry, this leads to objectionable noise. In the course of time several attempts have been made to solve this problem. One of said attempts was to increase the number of spot welds between the plate and the stiffening section. This measure only led to a limited reduction of the noise level, whilst this "solution" moreover had this drawback that the quality of the spot-welded joints may be affected when the distance between two spot welds becomes (too) small, because the cooling of the spot weld may be influenced by heat being passed through the material when a spot weld is made adjacently thereto. The brick industry itself has also searched for indirect solutions to the problem of noise nuisance caused by the supporting elements, such as the provision of noise cabins or encasings around spaces in the production process where the supporting elements cause noise nuisance. Furthermore, attempts have been made to make guides for the plates of a material that is said to have a sound-damping effect, e.g. HMPE. All these attempts have remained unsuccessful, however. So far, the desired result still has not been achieved.

[0003] Consequently it is an object of the present invention to provide a supporting element for drying bricks which provides a solution for the above problem, at least partially so, and which reduces the amount of noise nuisance to a considerable degree. According to the present invention, this object is accomplished by a supporting element as referred to in the introduction, wherein a spacer is provided between two points of attachment so as to keep the stiffening section spaced from the plate between said two points of attachment. Since spacers push the plate and the stiffening section away from each other between the two points of attachment, contact between the plate and the stiffening section is not entirely prevented but considerably reduced. After all, the spacer has a damping effect on the vibration of both the plate and the

stiffening section, as a result of which both the duration and the amplitude of the vibrations that occur during handling and transport are significantly reduced.

[0004] The Belgium patent BE 558649 discloses a support element according to the preamble of claim 1 and a method of manufacturing such a support element according to the preamble of claim 8.

[0005] German patent application DE 35 38 096 A1 discloses a supporting plate for drying stones which plate is provided with legs which keep the supporting plate at a distance from the underground at which the device is positioned. The supporting plate is provided with ribs at the bottom side of the supporting plate to make the supporting plate more rigid.

[0006] In a special embodiment of the invention, the spacer functions as a means of attachment, and the location at which the spacer is present between the plate and the stiffening section can be regarded as a point of attachment. This special embodiment provides a supporting element for bricks being dried while being supported thereon, comprising a plate with downwardly extending plate edges, between which plate edges a stiffening section extends, which stiffening section is connected to the plate at spaced-apart points of attachment on the bottom side of the plate, wherein a spacer is provided as a means of attachment at at least one point of attachment for attaching the stiffening section to the plate and keeping it spaced therefrom. The advantages are the same as with the supporting element as discussed above, an additional advantage being the fact that no separate means or methods of attachment are required for interconnecting the plate and the stiffening section.

[0007] A suitable variant to this special embodiment is an embodiment in which the point of attachment extends a certain length, for example at least substantially the entire length of the stiffening section. In that case the invention relates to a supporting element for bricks being dried while being supported thereon, comprising a plate with downwardly extending plate edges, between which plate edges a stiffening section extends along a certain length, which stiffening section is connected to the plate at spaced-apart points of attachment on the bottom side of the plate, which means of attachment comprise at least one spacer for keeping the stiffening section spaced from the plate at least substantially along the length thereof. This could be realised, for example, by means of a joint comprising a putty or a glue having elastic properties being resistant to the repeated temperature fluctuations that are used in drying bricks.

[0008] The stiffening section is preferably an elongated section having a U-shaped cross-section, the ends of the legs of the stiffening section being flanged to form section edges used for connecting the stiffening section to the plate. The U-shape imparts a sufficient degree of rigidity to the supporting element to prevent the plate from deflecting under the load of the bricks. Especially before the baking process, the bricks are comparatively heavy on account of the water that is present in the clay or the

loam. The section edges extend parallel to the plate and thus provide a projecting surface for interconnecting the plate and the stiffening sections. If the ends of the legs furthermore extend away from each other, it will be easier to handle the section when connecting it to the plate.

[0009] Preferably, a spacer is provided between respective pairs of adjacent points of attachment of a section edge. It will be understood that in this way the damping effect of the spacer will be greatest.

[0010] The spacer is preferably made of a resilient material. Although hard materials effectively reduce noise pollution as well, in that they push the plate and the stiffening section apart, a resilient material will provide an even better damping effect.

[0011] The spacer is preferably resistant against repeated temperature fluctuations in the range from about 0 °C to about 120 °C. This ensures that the properties of the material will be retained after a number of drying and baking cycles of bricks on the plate.

[0012] In a preferred embodiment of the invention, a spacer comprises elements made of plastic material. There are many plastics that have been good vibration damping properties, and the elements can be fitted between the plate and the stiffening section in a simple manner. Once the plate and the stiffening section are interconnected, the force that is exerted on the elements by the plate and the stiffening section may already suffice for holding the plastic elements in their clamped-down position. It is also possible to bond the plastic elements to the plate and/or the stiffening section or attach them in another manner.

[0013] In another preferred embodiment of the invention, the spacer comprises a filler material, for example a suitable putty or a suitable foam material such as PUR. A suitable filler material is easy to provide on the plate or the stiffening section and, after possible curing, will have a damping effect on the vibration of the stiffening section relative to the plate.

[0014] In yet another preferred embodiment of the invention, the spacer comprises a tape. Tape, too, is easy to provide and can be affixed to the plate or in the stiffening section relatively long before the plate and the stiffening section are interconnected, without any of the desired properties noticeably deteriorating.

[0015] The present invention further relates to a method for manufacturing a supporting element, comprising the steps of forming the plate and connecting the stiffening section to the bottom side of the plate, wherein a spacer is provided on the plate and/or the section edges, between two spot welds to be formed, prior to said connecting step. Providing the spacer in advance is easy because both the plate and the section edges are readily accessible. Especially in those cases where the spacer is provided on the section edges, a correct positioning will moreover be easy to realise. Only the positions of the points of attachment to be subsequently formed need to be taken into account in that case.

[0016] Preferably, a local difference in level is provided

in the plate and/or the stiffening section for positioning the spacer. In the first place, the local difference in level provides a marker point that helps to position the spacer correctly. In the second place, local differences in level help to prevent spacers from being displaced during the period between the provision of the spacers and the connection of the stiffening section to the plate.

[0017] The present invention will be explained in more detail hereinafter by means of a description of a preferred embodiment of the invention, in which reference is made to the following schematic figures:

Figure 1 shows part of a supporting plate for drying bricks;

Figure 2 is a sectional view along the line II-II in figure 1; and

Figure 3 is a sectional view along the line III-III in figure 1.

Figures 4, 6 and 5, 7 are sectional views corresponding to figures 2 and 3, respectively, of an embodiment in which the spacers also function as means of attachment.

[0018] With reference to figure 1, there is shown a supporting plate 1, whose bottom side faces upwards. The supporting plate 1 consists of a perforated plate 2, which is provided with upright edges 3 at the long sides and the short sides, which edges enable a good circulation of air via the bottom side of the plate during the drying process of bricks (not shown) that are present on the supporting plate. A U-shaped section 4 extends along the length of the brick drying plate 1, the ends of the legs of said U-shape being bent outwards at right angles so as to form edges 5. The section 4 prevents the plate 2 from deflecting when bearing the weight of the stones before or after drying. The section 4 is connected to the plate 2 by means of spot welds 6.

[0019] Figure 2 is a longitudinal sectional view of a part of the brick drying plate 1 of figure 1 along the line II-II, in which a spacer, in this case in the form of a plate 7 of plastic material is shown to be present between the plate 2 and the edge 5 of the section, between two adjacent spot welds 6a and 6b. When the brick drying plate 1 is being lifted or moved on a conveyor, the plate 7 of plastic material prevents the section edge 5 and the plate 2 from vibrating against each other and thereby causing noise nuisance.

[0020] Figure 3 is a cross-sectional view of a part of the brick drying plate 1 of figure 1, along the line III-III in said figure. This figure clearly shows that the section 4 has two edges 5, and that a plate 7 of plastic material is provided between the section 4 and the plate 2 at every edge 5.

[0021] Figures 4 and 5 are a longitudinal sectional view and a cross-sectional view (along the line V-V), respectively, of a supporting plate 11 comprising a plate 12 and a section 14 that is attached to the plate 12 at points of attachment by means of putty 18. The putty 18 consists

of an elastic material and as such also functions as a spacer.

[0022] Figures 6 and 7 are a longitudinal sectional view and a cross-sectional view (along the line VII-VII), respectively, of a supporting plate 21 comprising a plate 22 and a section 24 that is attached to the plate 22 at points of attachment by means of putty 28. The putty 28 consists of an elastic material and as such also functions as a spacer.

[0023] The preferred embodiment as described above and shown in the figures merely serves to illustrate the invention. The preferred embodiment must not be construed as limiting the scope of the present invention, which is defined in the appended claims. Many adaptations that will be obvious to those skilled in the art are possible, such as the provision of a layer of filling material or a strip of tape instead of the plate of plastic material. Instead of the plate of plastic material, also other materials having different shapes may be used.

Claims

1. A supporting element (1) for bricks that are dried while being supported thereon, comprising a plate (2) with downwardly extending plate edges (3), between which plate edges a stiffening section (4) extends, which stiffening section is connected to the plate at spaced-apart points of attachment (6, 6a, 6b) on the bottom side of the plate, **characterized in that** a spacer (7, 18, 28) is provided between two points of attachment so as to keep the stiffening section spaced from the plate between said two points of attachment.
2. A supporting element according to claim 1, **characterized in that** the stiffening section (4) is an elongated section having a U-shaped cross-section, the ends of the legs of the stiffening section being flanged to form section edges (5) used for connecting the stiffening section to the plate (2).
3. A supporting element according to claim 2, **characterized in that** a spacer (7) is provided between respective pairs of adjacent points (6a, 6b) of attachment of a section edge (5).
4. A supporting element according to any one or more of the preceding claims, **characterized in that** the spacer (7, 18, 28) is made of a resilient material.
5. A supporting element according to any one or more of the preceding claims, **characterized in that** said spacer (7) comprises an element of plastic material.
6. A supporting element according to any one or more of the claims 1-4, **characterized in that** said spacer (18, 28) comprises putty or a foam as a filler material.
7. A supporting element according to any one or more of the claims 1-4, **characterized in that** said spacer comprises a tape.
8. A method for manufacturing a supporting element (1) according to any one of the preceding claims, comprising the following steps:
 - forming the plate (2), and
 - connecting the stiffening section (4) to the bottom side of the plate,**characterized in that** a spacer (7, 18, 28) is provided on the plate (2) and/or the section edges (5), between two spot welds (6, 6a, 6b) to be formed, prior to said connecting step.
9. A method according to claim 8, **characterized in that** a local difference in level is provided in the plate and/or the stiffening section for positioning the spacer.

Patentansprüche

1. Trägerelement (1) für Ziegel, die getrocknet werden während sie darauf getragen werden, das eine Platte (2) mit sich nach unten erstreckenden Plattenrändern (3) aufweist, wobei sich zwischen den Plattenrändern ein Aussteifungsabschnitt (4) erstreckt, wobei der Aussteifungsabschnitt an beabstandeten Befestigungspunkten (6, 6a, 6b) an der Bodenseite der Platte mit der Platte verbunden ist, **dadurch gekennzeichnet, dass** ein Abstandhalter (7, 18, 28) zwischen zwei Befestigungspunkten vorgesehen ist, um so den Aussteifungsabschnitt zwischen den zwei Befestigungspunkten von der Platte beabstandet zu halten.
2. Trägerelement nach Anspruch 1, **dadurch gekennzeichnet, dass** der Aussteifungsabschnitt (4) ein länglicher Abschnitt mit einem U-förmigen Querschnitt ist, wobei die Enden der Schenkel des Aussteifungsabschnitts abgeflanscht sind, um Abschnittsränder (5) auszubilden, die zum Verbinden des Aussteifungsabschnitts mit der Platte (2) verwendet werden.
3. Trägerelement nach Anspruch 2, **dadurch gekennzeichnet, dass** ein Abstandhalter (7) zwischen entsprechenden Paaren von benachbarten Verbindungspunkten (6a, 6b) eines Abschnittsrandes (5) vorgesehen ist.
4. Trägerelement nach einem oder mehreren der vorangehenden Ansprüche, **dadurch gekennzeichnet, dass** der Abstandhalter (7, 18, 28) aus einem nachgiebigen Material hergestellt ist.

5. Trägerelement nach einem oder mehreren der vorangehenden Ansprüche, **dadurch gekennzeichnet, dass** der Abstandhalter (7) ein Element aus Kunststoffmaterial aufweist.
6. Trägerelement nach einem oder mehreren der Ansprüche 1 bis 4, **dadurch gekennzeichnet, dass** der Abstandhalter (18, 28) Spachtelmasse oder einen Schaum als ein Füllmaterial aufweist.
7. Trägerelement nach einem oder mehreren der Ansprüche 1 bis 4, **dadurch gekennzeichnet, dass** der Abstandhalter ein Band aufweist.
8. Verfahren zur Herstellung eines Trägerelements (1) nach einem der vorangehenden Ansprüche, das die folgenden Schritte aufweist:
- Ausbilden der Platte (2), und
Verbinden des Aussteifungsabschnitts (4) mit der Bodenseite der Platte,
- dadurch gekennzeichnet, dass** vor dem Verbindungsschritt ein Abstandhalter (7, 18, 28) an der Platte (2) und/oder den Abschnittsrändern (5) zwischen zwei auszubildenden Punktschweißungen (6, 6a, 6b) vorgesehen wird.
9. Verfahren nach Anspruch 8, **dadurch gekennzeichnet, dass** ein lokaler Niveauunterschied in der Platte und/oder dem Aussteifungsabschnitt zum Positionieren des Abstandhalters vorgesehen wird.

Revendications

1. Élément de support (1) pour briques qui sont séchées tout en étant transportées sur celui-ci, comprenant une plaque (2) avec des bords de plaque (3) s'étendant vers le bas, entre lesquels bords de plaque, une section de raidissement (4) s'étend, laquelle section de raidissement est raccordée à la plaque au niveau de points de fixation (6, 6a, 6b) espacés sur le côté inférieur de la plaque, **caractérisé en ce qu'**un dispositif d'espacement (7, 18, 28) est prévu entre deux points de fixation afin de maintenir la section de raidissement espacée de la plaque entre lesdits deux points de fixation.
2. Élément de support selon la revendication 1, **caractérisé en ce que** la section de raidissement (4) est une section allongée ayant une section transversale en forme de U, les extrémités des pattes de la section de raidissement ayant un rebord pour former des bords de section (5) utilisés pour raccorder la section de raidissement à la plaque (2).
3. Élément de support selon la revendication 2, **carac-**

térisé en ce qu'un dispositif d'espacement (7) est prévu entre des paires de points de fixation (6a, 6b) adjacents d'un bord de section (5).

4. Élément de support selon l'une quelconque ou plusieurs des revendications précédentes, **caractérisé en ce que** le dispositif d'espacement (7, 18, 28) est réalisé avec un matériau élastique.
5. Élément de support selon l'une quelconque ou plusieurs des revendications précédentes, **caractérisé en ce que** ledit dispositif d'espacement (7) comprend un élément en matière plastique.
6. Élément de support selon l'une quelconque ou plusieurs des revendications 1 à 4, **caractérisé en ce que** le dispositif d'espacement (18, 28) comprend du mastic ou une mousse en tant que matière de remplissage.
7. Élément de support selon l'une quelconque ou plusieurs des revendications 1 à 4, **caractérisé en ce que** ledit dispositif d'espacement comprend une bande.
8. Procédé pour fabriquer un élément de support (1) selon l'une quelconque des revendications précédentes, comprenant les étapes suivantes consistant à :
- former la plaque (2), et
raccorder la section de raidissement (4) au côté inférieur de la plaque,
- caractérisé en ce qu'**un dispositif d'espacement (7, 18, 28) est prévu sur la plaque (2) et/ou les bords de section (5), entre deux soudures par points (6, 6a, 6b) à former, avant ladite étape de raccordement.
9. Procédé selon la revendication 8, **caractérisé en ce qu'**une différence locale de niveau est prévue dans la plaque et/ou la section de raidissement pour positionner le dispositif d'espacement.

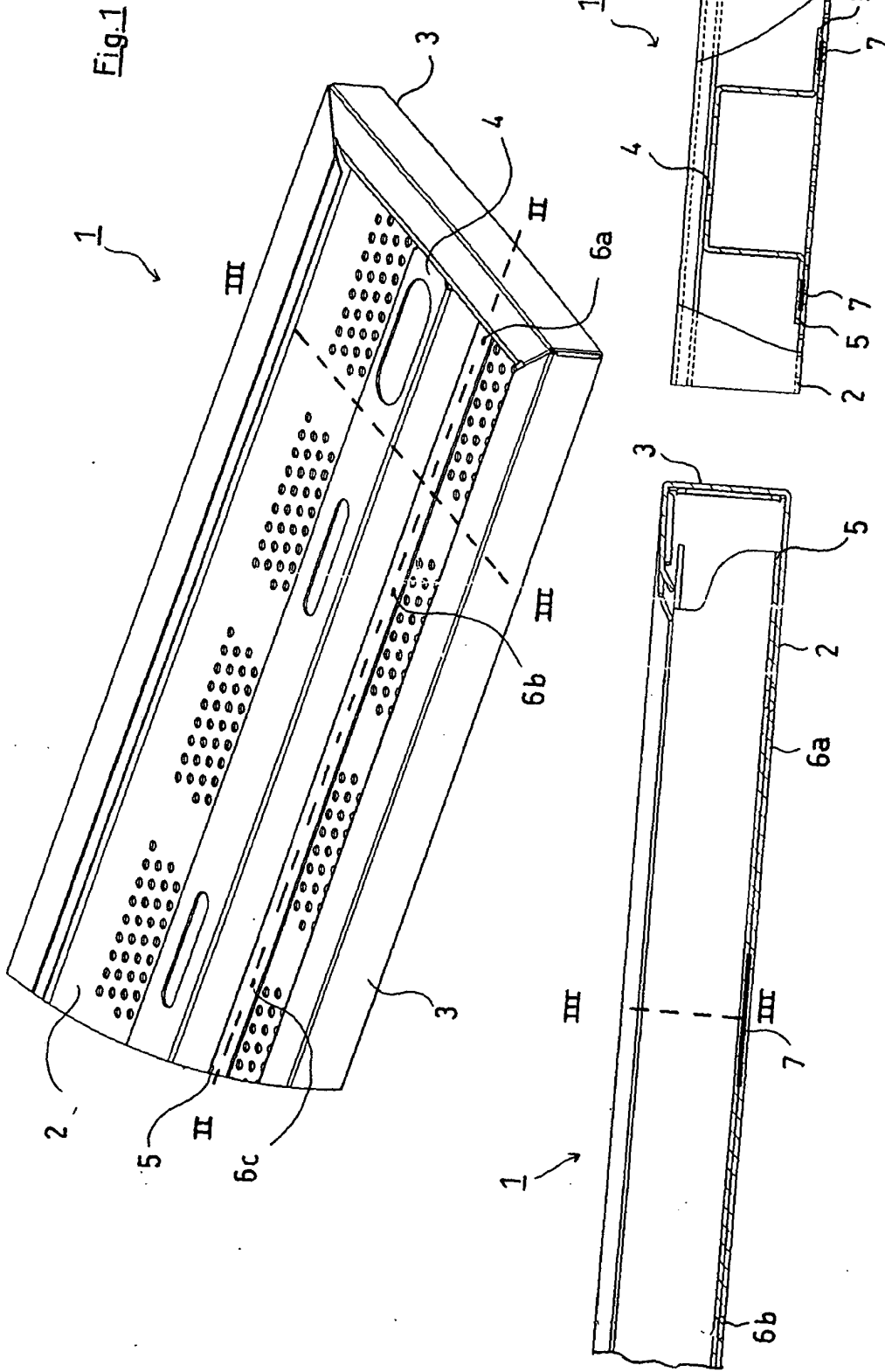

Fig.1

Fig.2

Fig.3

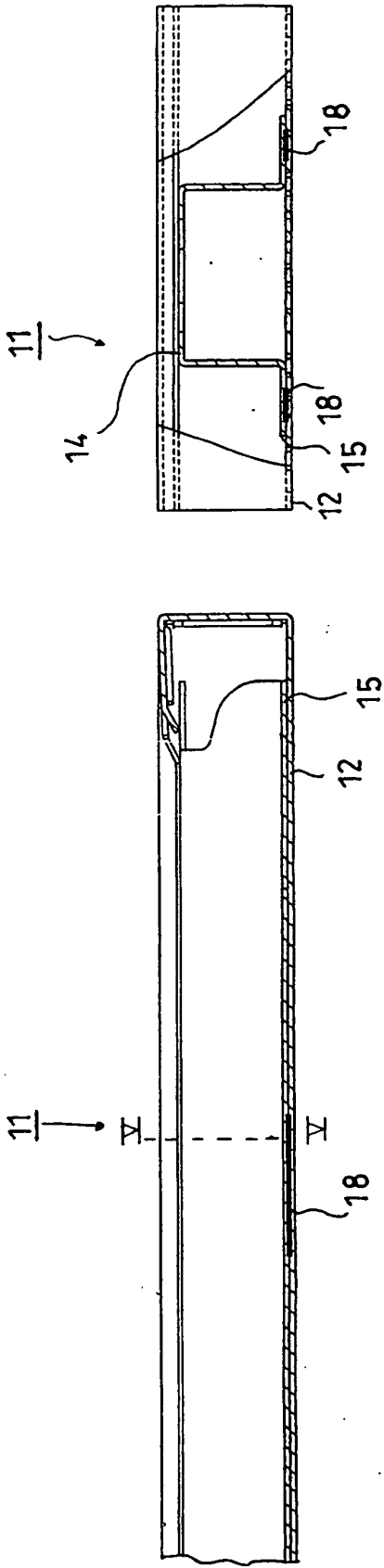

Fig. 4

Fig. 5

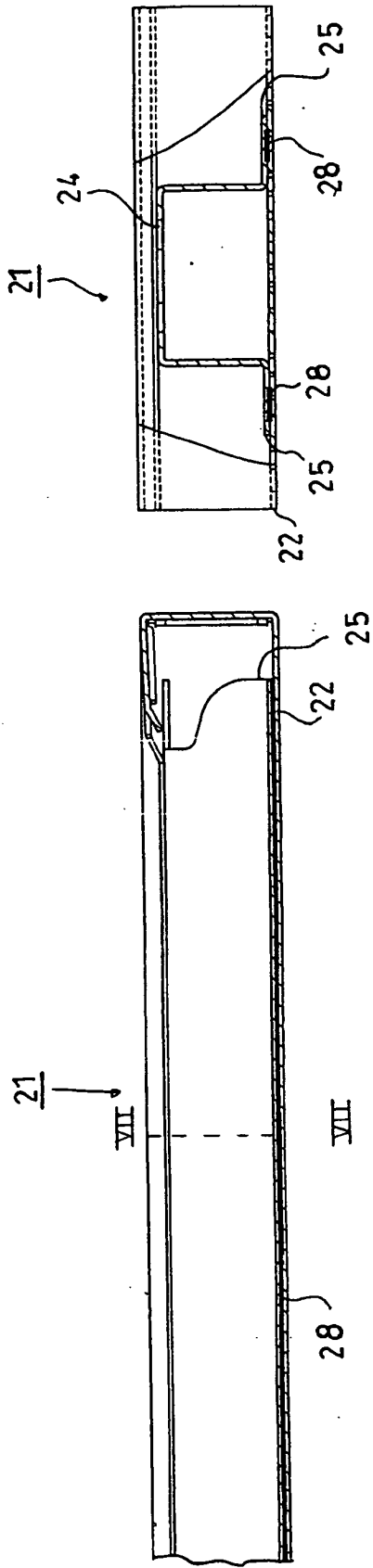

Fig. 6

Fig. 7

REFERENCES CITED IN THE DESCRIPTION

This list of references cited by the applicant is for the reader's convenience only. It does not form part of the European patent document. Even though great care has been taken in compiling the references, errors or omissions cannot be excluded and the EPO disclaims all liability in this regard.

Patent documents cited in the description

- BE 558649 [0004]
- DE 3538096 A1 [0005]