

H. T. Lee,

Piston Packing.

No. 102,137.

Patented Apr. 19. 1870.

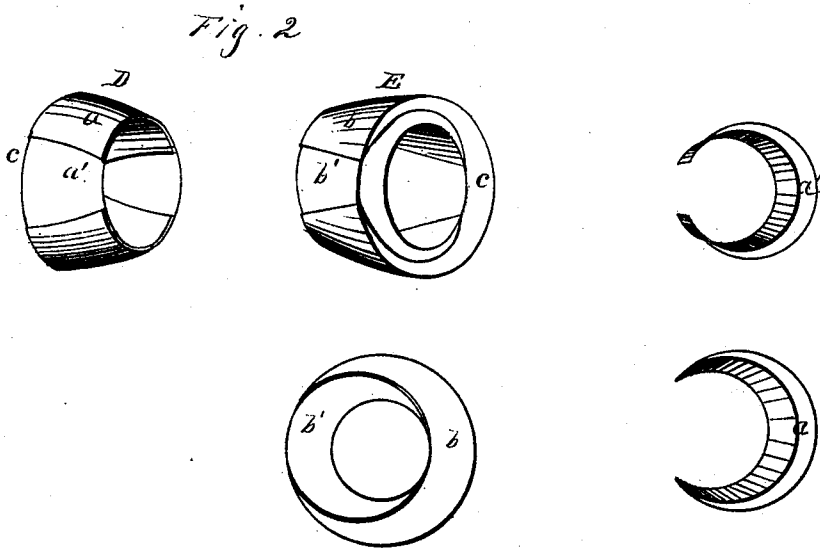
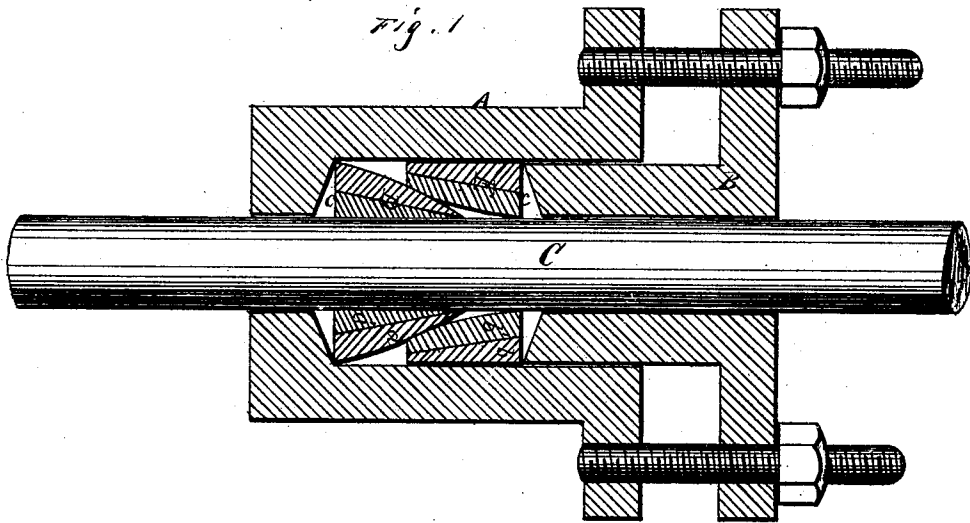

Witnesses:  
Wm. R. Boone.  
Wm. Gerlach.

Inventor:  
Harvey J. Lee  
by Dewey & Co.  
His Attys

# United States Patent Office.

HARVEY THOMAS LEE, OF MARYSVILLE, CALIFORNIA.

Letters Patent No. 102,137, dated April 19, 1870.

## PISTON-ROD PACKING.

The Schedule referred to in these Letters Patent and making part of the same.

*To all whom it may concern.*

Be it known that I, HARVEY THOMAS LEE, of Marysville, county of Yuba, State of California, have invented an improved Method of Packing Piston-Rods and Valve-Stems; and I do hereby declare the following description and accompanying drawings are sufficient to enable any person skilled in the art or science to which it most nearly appertains to make and use my said invention or improvements, without further invention or experiment.

My invention relates to an improved manner of constructing metallic packing-rings for piston-rods and valve-stems, in order to render the joint tight and easily adjustable, if at any time it wears sufficiently to leak.

My invention is also easily applicable to any working engine during the few minutes of an ordinary stoppage.

It consists of two beveled or conically-shaped rings which clasp the piston-rod or valve-stem inside the cage of the stuffing-box, one of the rings fitting directly against the rod, and having the beveled edge toward one end of the space, while the other ring faces it, as it were, so that its beveled edge clasps the outside of the first ring.

When the gland or follower is screwed down against this packing, the last-mentioned ring is forced further over the inner one, causing it to clasp the rod more tightly, while the outer one is forced against the outside of the cage, thus making a tight joint.

Each of these rings is made in two parts, or cut, each part having an open space between the ends that are parallel to the axis of the ring, and one part clasping or embracing the other in such a position that these spaces may be on opposite sides; the aforesaid ends being tapered off to a thin edge, so that the two parts together form a ring of which both the outer and the inner circumference are circles.

Referring to the accompanying drawings for a more complete explanation of my invention—

A is the cage, and

B, the gland of a stuffing-box, such as is in ordinary use for piston-rods, valve-stems, and similar moving joints.

The piston-rod or stem C, as the case may be, moves back and forward, as shown. In order to pack this, or

render it steam-tight and keep it so, I introduce two rings D and E, shown at Figure 2.

These rings are made of any of the metals or compositions which serve the purposes of packing, and are made in two parts, the parts *a* and *a'* forming the ring D, and the parts *b* and *b'* the ring E, so that they can be compressed or enlarged as may be necessary.

The rings are made of considerable thickness at one end, *c*, and are beveled to an edge at the other end, as shown.

The ring D clasps the rod C, and the ring E is placed as shown in Figure 1, so that its beveled edge clasps that of the ring D.

In this position it is evident that when the gland is forced down against the packing one of the rings will rest against the inner end of the cage, while the other will be forced forward by the gland.

This causes the ring E to slide further over the ring D, and force it more closely against the rod, while the outer one E will be expanded against the inner surface of the cage, the parts *a* and *a'* of the one ring and the parts *b* and *b'* of the other allowing this motion.

The cut rings are intended to break joints so as to prevent escape of steam through the openings.

I make my rings of Babbitt metal, or other soft metal which will adjust itself to its bearings, under pressure, sufficiently to compensate any change of figure liable to be caused by wear, and the consequent expansion of one ring and contraction of the other.

Having thus described my invention,

What I claim, and desire to secure by Letters Patent, is—

The packing formed by the two divided beveled rings D and E, the beveled edge of one fitting into that of the other, so that the pressure of the gland will cause the outer one to expand against the sides of the stuffing-box, while the other is compressed against the rod or stem, substantially as described.

In witness that the above-described invention is claimed by me, I have hereunto set my hand and seal.

HARVEY T. LEE. [L. s.]

Witnesses:

J. L. BOONE,  
W. R. BOONE.