

J. Breedon,

Faucet.

No. 100,113.

Patented Feb. 22, 1870.

FIG I

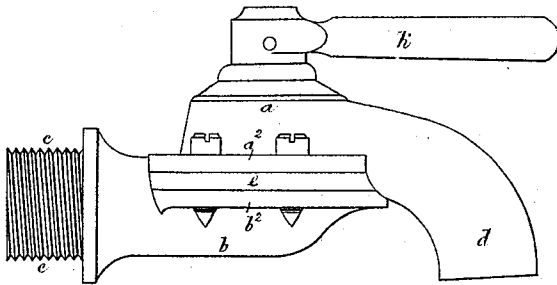

FIG V

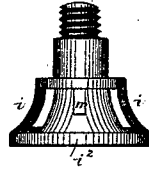

FIG II

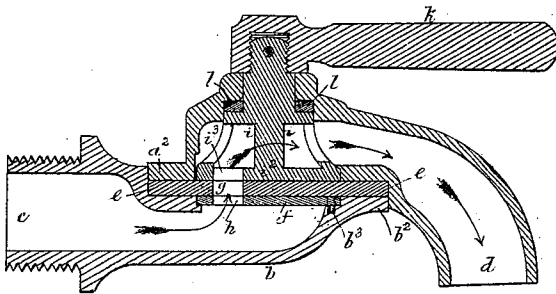

FIG VI

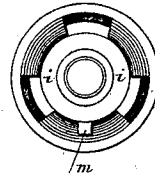

FIG VII

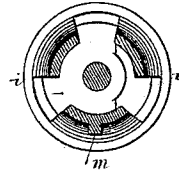

FIG III

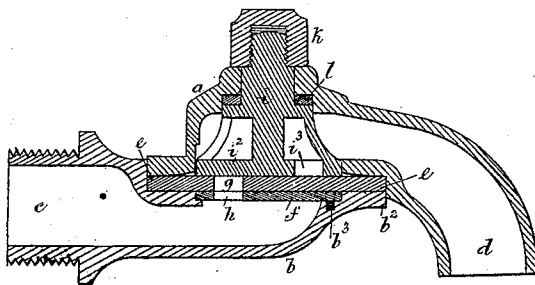

FIG VIII

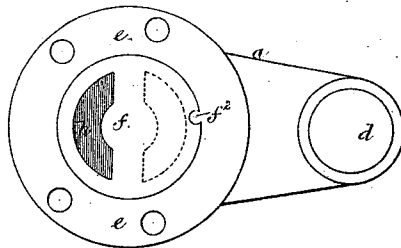

FIG IV

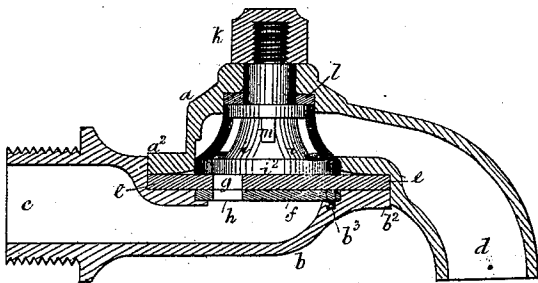
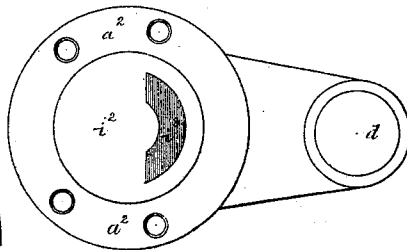

FIG IX



Witnesses { George Shaw
Richard Bennett

Joseph Breedon

J. Brecken,

2. Sheets. Sheet. 2.

Faucet.

No. 100,113.

Patented Feb. 22. 1870.

FIG X

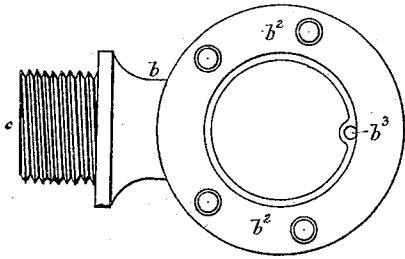

FIG XI

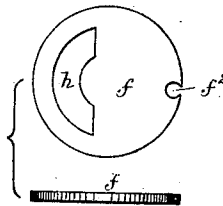

FIG XII

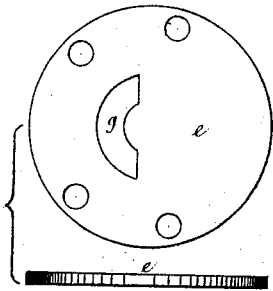

FIG XIII

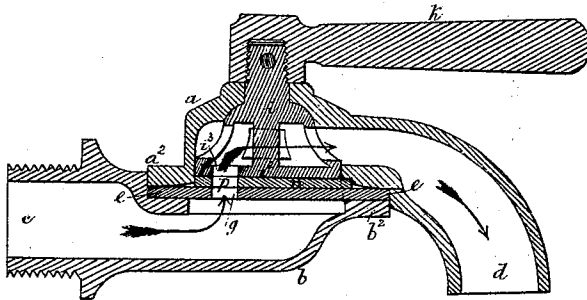

FIG XIV

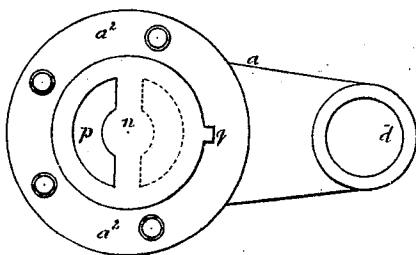
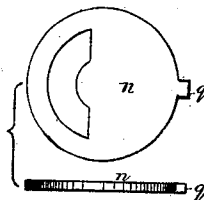

FIG XV



Witnesses { *George Shaw*
Richard Kerrett

Joseph Brecken

United States Patent Office.

JOSEPH BREEDEN, OF BIRMINGHAM, ENGLAND.

Letters Patent No. 100,113, dated February 22, 1870; Patented in England February 23, 1869.

IMPROVEMENT IN STOP-COCKS

The Schedule referred to in these Letters Patent and making part of the same.

To all to whom it may concern:

Be it known that I, JOSEPH BREEDEN, of the firm of J. and W. Breeden & Booth, of Birmingham, in the county of Warwick, England, manufacturers, a subject of the Queen of Great Britain, have invented or discovered new and useful Improvements in Taps or Stop-Cocks; and I, the said JOSEPH BREEDEN, do hereby declare the nature of said invention, and in what manner the same is to be performed, to be particularly described and ascertained in and by the following statement thereof, that is to say:

My invention consists in constructing and arranging the parts of taps or stop-cocks for liquids and fluids in the following manner: The body of the tap is made in two halves or parts, joined together by flanges, the said body having internally the general figure of a hollow cylinder. The entrance pipe opens into the lower half or part, and the exit pipe into the upper half or part of the body. A circular disk of strong and hard leather is inserted and fixed between the flanges of the two parts of the body of the tap, the said disk constituting a diaphragm extending across the middle of the said body. This diaphragm has one or more perforations in it, through which the liquid or fluid passes, and on the lower side of the said diaphragm is fixed a metal strengthening plate, having an opening in it coincident with that in the diaphragm. In the upper half of the body is a plug, the lower portion of which is of the same diameter as the body, and works closely but freely therein.

The upper end or stem of the plug passes out at the top of the tap, and is provided with a handle or with a lever for giving a rotary motion to the plug. The lower end of the plug bears upon the upper side of the leather diaphragm, and has a hole in it similar in size, shape, and position to that in the diaphragm. When the plug is turned so as to bring the opening in the plug over that in the diaphragm, communication is opened between the entrance and exit pipes of the tap, and liquid or fluid may pass through the tap. When the plug is so turned that the opening in it no longer coincides with that in the diaphragm the tap is closed.

The stem of the plug has a shoulder, between which and the top of the body washers of leather are placed so as to prevent the escape of liquid or fluid at the handle of the tap.

The pressure of the liquid or fluid upon the diaphragm keeps it in close contact with the bottom of the plug, and hence the greater the pressure the more closely will the diaphragm be held against the bottom of the plug. By means of a stop on the plug motion in either direction is limited.

Having explained the nature of my invention, I will proceed to describe, with reference to the accompanying drawings, the manner in which the same is to be performed.

Figure 1 represents, in side elevation, and Figure 2, in longitudinal vertical section, a tap or stop-cock made according to my invention, the said tap or stop-cock being open for the passage of liquid or fluid.

Figures 3 and 4 represent the tap or stop-cock closed, the plug being represented in section in fig. 3, and in elevation in fig. 4.

Figure 5 represents the plug in elevation.

Figure 6, a plan of upper side, and

Figure 7, a horizontal section of the plug separately.

Figures 8 and 9 are plans of one part of the body of the tap, and

Figure 10 is a plan of the other part of the body.

Figures 11 and 12 are parts of the tap, as herein-after explained.

The same letters of reference indicate the same parts in each figure of the drawings.

$a b$ are the two parts or halves of the body of the tap, joined together by the flanges $a^2 b^2$.

The entrance pipe c opens into the lower part b , and the exit pipe d opens into the upper part a of the body.

Between the two parts or halves $a b$ of the body of the tap, and fixed by the flanges $a^2 b^2$, is a strong and hard leather disk, e , the said disk constituting a diaphragm extending across the middle of the body of the tap. The disk e is shown separately in fig. 12.

The said diaphragm is supported and strengthened by the metal disk or plate f under it, as represented, the said disk being dropped into a depression in the part b of the body. The disk or plate f is represented separately in fig. 11.

In the plan, fig. 8 of the part a of the body of the tap, the said disk or plate f is shown upon the diaphragm e ; but in the plan fig. 9, of the said part a , the said disk or plate and diaphragm are removed, so as to exhibit the bottom of the plug.

The disk or plate f is fixed in its place and prevented from rotating by means of a pin or stud, b^3 , on the part b of the body (see fig. 10) engaging with a hole, f^2 at the edge of the disk or plate, as represented.

The said diaphragm e has an opening or perforation, g , in it, through which the liquid or fluid passes, and the strengthening plate f has a similar-shaped opening or perforation, h , in it, coincident with the opening g in the diaphragm e .

i is the plug, working in the upper part a of the body of the tap. The lower end or disk i^2 of the said plug is of the same diameter as the interior of the part a of the body, and works closely but freely therein, as seen in the sections.

The face of the bottom or disk i^2 of the plug bears against the upper side of the diaphragm e , and the said disk i^2 has a perforation or opening, i^3 , similar in size, shape and position to that in the diaphragm e . The plug is hollow, and its sides are perforated as repre-

sented, to allow of the free passage of liquid or fluid through it to the exit pipe *d*.

The plug *i* is turned by a lever, *k* (or handle) fixed at the upper end of its stem, and the escape of liquid or fluid between the stem and the upper part of the body of the tap is prevented by the washer *l*, situated between a shoulder on the stem and the inner side of the part *a* of the body. When the lever *k* is turned so as to bring the opening *i*² in the plug opposite the openings *g* *h* in the diaphragm *e* and strengthening plate *f*, the tap is opened as illustrated in fig. 2, and the liquid or fluid passes from the entrance pipe *c* through the openings *h* *g* *i*² and hollow plug *i* to the exit pipe *d*, as indicated by the arrows in fig. 2. By turning the lever *k* half a rotation, the opening *i*² in the plug no longer coincides with the opening *g* in the diaphragm *e*, and the tap is closed by an unperforated part of the plug being brought over the opening in the diaphragm, as illustrated in figs. 3 and 4.

On the plug *i* is a stop, *m*, (see figs. 4 and 6,) by which its motion in either direction, to open or close the tap, is limited. This stop *m*, on turning the plug, comes against one or other of two projections made at opposite points in the upper part or half *a* of the body.

By an examination of the drawing it will be seen that the liquid or fluid enters the tap below the diaphragm *e*, and by its pressure against the said diaphragm and strengthening plate keeps the said diaphragm in close contact with the bottom of the plug, and hence the greater the pressure the more closely will the diaphragm be held against the bottom of the plug.

Figure 13 represents in section a modification of the last-described tap, the said modification being specially fitted for controlling the passage of hot water.

Figures 14 and 15 are parts of the same.

In this arrangement I use a diaphragm, *e*, of vulcanized India rubber instead of leather, and instead of

making the bottom *i*² of the plug *i* work directly on the upper side of the diaphragm, I interpose between the said diaphragm and plug a metal disk, *n*, incapable of rotation, against the upper face of which metal disk the bottom of the plug bears as represented.

The metal disk *n* has an opening, *p*, in it, which coincides with the opening *g* in the diaphragm *e*.

The disk *n* is represented separately in fig. 15, and is fixed in the upper half or part *a* of the body by means of the tooth or projection *q* engaging in a recess in the said upper half *a*, as seen in the plan, fig. 14.

I make the disk *n* and the plug *i* *i*² of dissimilar metals, the disk being made by preference of gun metal. The action of the tap, fig. 13, is the same as that herein first described.

In some cases the diaphragm *e*, figs. 12 and 13, may be dispensed with, and the disk *n* only be employed. In this modification the disk *n* is supported by the flange *b*² of the lower half of the body of the opening, which is made smaller than that represented in fig. 13. A ring of India rubber is interposed between the two flanges *a*² and *b*².

What I claim as my invention, and desire to secure by Letters Patent, is—

1. The arrangement and combination of the perforated diaphragm *e* and perforated hollow plug *i* *i*², bearing directly on said diaphragm, as herein shown and described; and

2. The combination and arrangement of the perforated disk or plate *n* and perforated hollow plug *i* *i*², bearing directly on said disk or plate, as shown and described, the said diaphragm or plate being pressed closely against the said plug by the pressure of the liquid or fluid entering the tap or stop-cock as specified.

JOSEPH BREEDEN. [L. S.]

Witnesses:

GEORGE SHAW, } 7 Cannon street,
RICHARD SKERRETT, } Birmingham.