

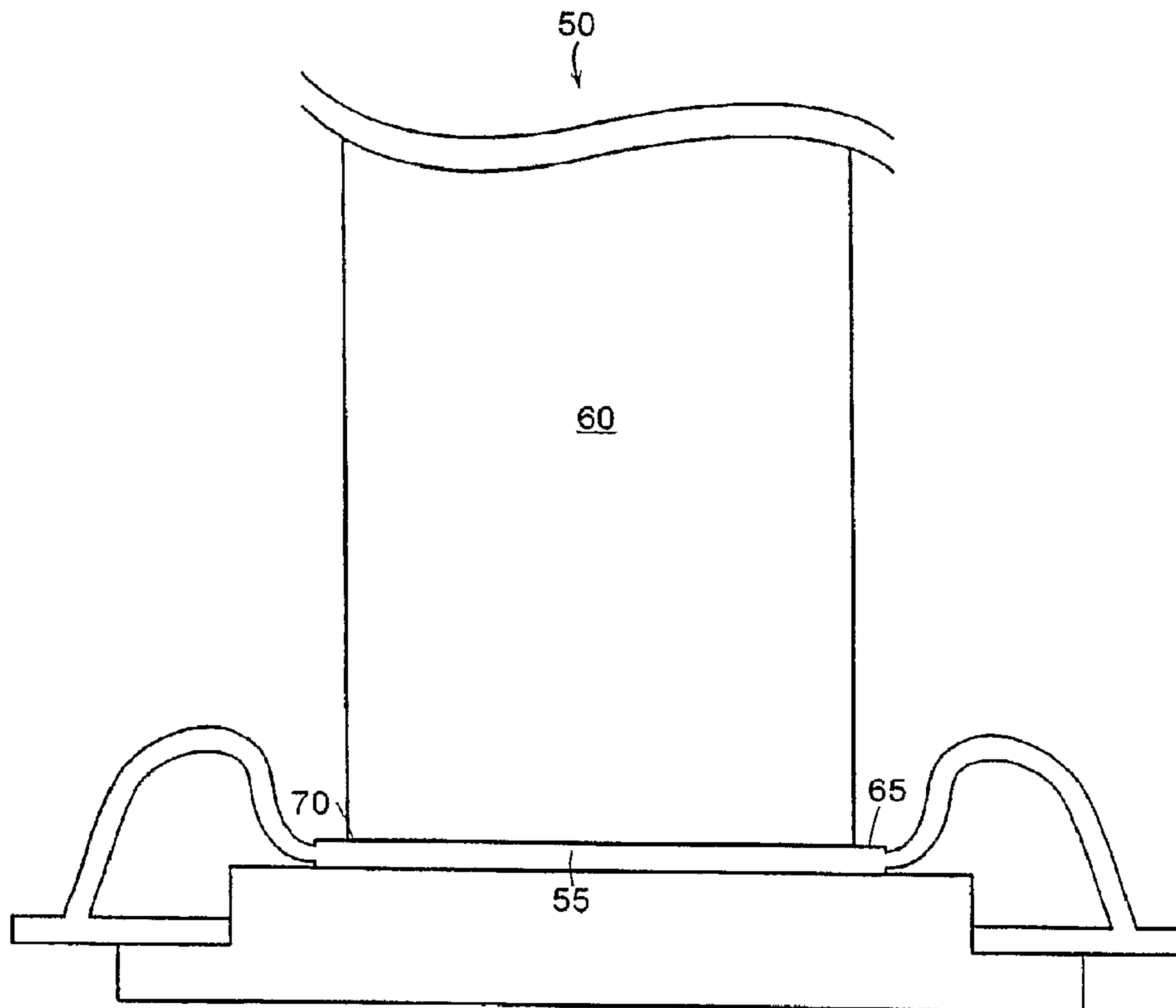

(86) Date de dépôt PCT/PCT Filing Date: 2006/12/19
 (87) Date publication PCT/PCT Publication Date: 2007/07/12
 (45) Date de délivrance/Issue Date: 2015/05/26
 (85) Entrée phase nationale/National Entry: 2008/06/25
 (86) N° demande PCT/PCT Application No.: US 2006/048427
 (87) N° publication PCT/PCT Publication No.: 2007/078941
 (30) Priorité/Priority: 2005/12/30 (US11/323,481)

(51) Cl.Int./Int.Cl. *G02B 6/42* (2006.01),
G02B 6/26 (2006.01)
 (72) Inventeurs/Inventors:
KRUPA, ROBERT J., US;
ROOT, THOMAS, US
 (73) Propriétaire/Owner:
OPTIM, INC., US
 (74) Agent: RICHES, MCKENZIE & HERBERT LLP

(54) Titre : DISPOSITIF D'ECLAIRAGE
 (54) Title: ILLUMINATION DEVICE



(57) Abrégé/Abstract:

Illumination devices include a light source including a substantially planar light-emitting surface and an optical rod or optical taper disposed proximate to the substantially planar light-emitting surface to optically couple the optical rod and the substantially planar light-emitting surface.

(12) INTERNATIONAL APPLICATION PUBLISHED UNDER THE PATENT COOPERATION TREATY (PCT)

(19) World Intellectual Property Organization
International Bureau(43) International Publication Date
12 July 2007 (12.07.2007)

PCT

(10) International Publication Number
WO 2007/078941 A1(51) International Patent Classification:
G02B 6/42 (2006.01) *G02B 6/26* (2006.01)(21) International Application Number:
PCT/US2006/048427(22) International Filing Date:
19 December 2006 (19.12.2006)

(25) Filing Language: English

(26) Publication Language: English

(30) Priority Data:
11/323,481 30 December 2005 (30.12.2005) US(71) Applicant (for all designated States except US): **OPTIM, INC.** [US/US]; 64 Technology Park Road, Sturbridge, MA 01566-1262 (US).

(72) Inventors; and

(75) Inventors/Applicants (for US only): **KRUPA, Robert, J.** [US/US]; 62 Indian Ridge Drive, Leominster, MA 01453 (US). **ROOT, Thomas** [US/US]; 8 Beatrice Road, Beverly, MA 01915 (US).(74) Agent: **BROCKMAN-LEE, Sandra, A.**; PROSKAUER ROSE LLP, One International Place, Boston, MA 02110 (US).

(81) Designated States (unless otherwise indicated, for every kind of national protection available): AE, AG, AL, AM, AT, AU, AZ, BA, BB, BG, BR, BW, BY, BZ, CA, CH, CN, CO, CR, CU, CZ, DE, DK, DM, DZ, EC, EE, EG, ES, FI, GB, GD, GE, GH, GM, GT, HN, HR, HU, ID, IL, IN, IS, JP, KE, KG, KM, KN, KP, KR, KZ, LA, LC, LK, LR, LS, LT, LU, LV, LY, MA, MD, MG, MK, MN, MW, MX, MY, MZ, NA, NG, NI, NO, NZ, OM, PG, PH, PL, PT, RO, RS, RU, SC, SD, SE, SG, SK, SL, SM, SV, SY, TJ, TM, TN, TR, TT, TZ, UA, UG, US, UZ, VC, VN, ZA, ZM, ZW.

(84) Designated States (unless otherwise indicated, for every kind of regional protection available): ARIPO (BW, GH, GM, KE, LS, MW, MZ, NA, SD, SL, SZ, TZ, UG, ZM, ZW), Eurasian (AM, AZ, BY, KG, KZ, MD, RU, TJ, TM), European (AT, BE, BG, CH, CY, CZ, DE, DK, EE, ES, FI, FR, GB, GR, HU, IE, IS, IT, LT, LU, LV, MC, NL, PL, PT, RO, SE, SI, SK, TR), OAPI (BF, BJ, CF, CG, CI, CM, GA, GN, GQ, GW, ML, MR, NE, SN, TD, TG).

Published:
— with international search report

[Continued on next page]

(54) Title: ILLUMINATION DEVICE

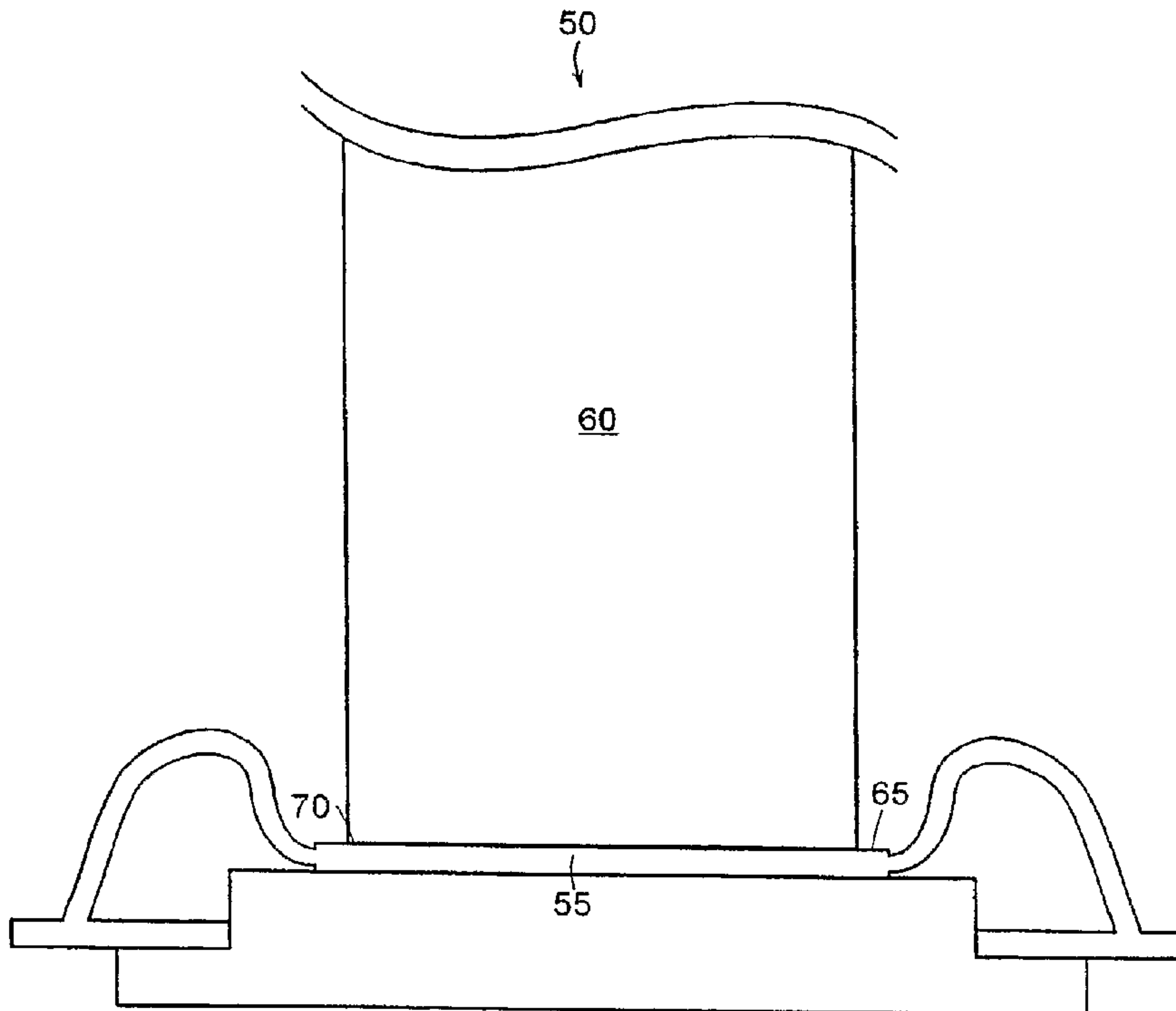

(57) Abstract: Illumination devices include a light source including a substantially planar light-emitting surface and an optical rod or optical taper disposed proximate to the substantially planar light-emitting surface to optically couple the optical rod and the substantially planar light-emitting surface.

WO 2007/078941 A1

WO 2007/078941 A1



For two-letter codes and other abbreviations, refer to the "Guidance Notes on Codes and Abbreviations" appearing at the beginning of each regular issue of the PCT Gazette.

ILLUMINATION DEVICE**FIELD OF THE INVENTION**

[0001] This invention relates to an illumination device including a substantially planar light-emitting surface coupled to an optical rod or optical taper.

BACKGROUND OF THE INVENTION

[0002] Advances in light source technology, such as, for example, light-emitting diode (LED) technology, have led to very bright and reliable solid state lamps. However, challenges remain with respect to coupling LEDs to optical transmission media, such as, for example, optical rods and optical tapers. While there have been numerous attempts to utilize low power (<1 W electrical power consumption, typically operating below 100mW) light-emitting diodes (LEDs) coupled to fiber optic light guides or other optical devices as light sources for endoscopy, dentistry, and for remote illumination of objects (as with a flashlight, head light, or lamp), most of these prior attempts have employed numerous low power LEDs for remote illumination. Generally, multiple LEDs are necessary because the light output from a single, low power LED is typically too weak to properly illuminate an object. In addition, the arrangement of the multiple LEDs to the optical transmission media used in these prior attempts has resulted in unacceptable light loss, thereby further decreasing the low power LED's ability to properly illuminate an object.

SUMMARY OF THE INVENTION

[0003] In general, the present invention relates to increasing the amount of light transmitted through an illumination device by means of an inventive coupling approach between a light source and an optical rod or optical taper. In some embodiments, the invention further relates to an endoscope (e.g., medical or industrial) including the inventive coupling approach, a lamp including the inventive coupling approach, or a head light including the inventive coupling

-2-

approach. Certain embodiments of the present invention, utilize a high power LED, (i.e., an LED having a power consumption between about 1 to 5W).

[0004] In one aspect, the invention relates to an illumination device, such as, for example, an endoscope, a lamp, or a head light. The illumination device includes a light source including a substantially planar light-emitting surface and an optical rod or optical taper disposed proximate to the substantially planar light-emitting surface. By arranging the optical rod or optical taper in a proximate relationship to the substantially planar light-emitting surface, the two elements are coupled in a manner which allows a large amount of the light emitted by the light source to be transmitted directly into the optical rod or optical taper. As a result, a greater amount of light from the light source can be transmitted through the illumination device and onto an object for illumination. Embodiments of the present invention do not include auxiliary optics, such as lenses or mirrors, disposed between the light source and the optical rod or optical taper, but instead rely on the close placement (e.g., direct contact or close proximity) of the optical rod or taper to the planar light-emitting region of the light source. The lack of auxiliary optics between the light source and the optical rod or optical taper simplifies the mechanical design and space requirements for the illumination device. As a result, illumination devices in accordance with the present invention can be small and compact while providing the desired illumination strength.

[0005] Embodiments of this aspect of the invention can include one or more of the following features. The substantially planar light-emitting surface can include an emitting surface of a light-emitting diode chip. In some embodiments, the substantially planar light-emitting surface can include the surface of a light-emitting diode chip that has been coated with a film of a substance that emits light when the light-emitting diode chip is activated (e.g., a phosphor film coating the surface of the chip). In certain embodiments, the substantially planar light-emitting surface comprises a transparent substantially planar window disposed over an

-3-

emitting surface of a light emitting diode chip. For example, in some embodiments, the window can be disposed directly over a LED chip. In other embodiments, the window can be disposed over a phosphor coated LED chip. The substantially planar light-emitting surface can be in direct contact with the optical rod or optical taper. In some embodiments an adhesive or index matching material (e.g., a coupling gel) can be disposed between the optical rod or optical taper and the substantially planar light-emitting surface. In certain embodiments, the optical rod or taper is disposed proximate to but not in direct contact with the substantially planar light-emitting surface. As a result, a gas is disposed between the optical rod or optical taper and the substantially planar light-emitting surface.

[0006] Other embodiments of this aspect of the invention can include one or more of the following features. The optical rod can be formed of a clad rod, a silvered rod, an aluminized rod, or a fiber bundle. The optical rod can have a first end that is proximate to the substantially planar light-emitting surface and a second end that is proximate to a light guide. The optical taper can include a first end that has a smaller surface area than a second end of the optical taper. In some embodiments, the first end (i.e., with the smaller surface area) can be in direct contact with the substantially planar light-emitting surface of the light source. In other embodiments, the second end (i.e., with the larger surface area) can be in direct contact with the substantially planar light-emitting surface of the light source. The optical taper can be formed of a glass optical taper, a plastic optical taper, or a plurality of fibers. While one end of the optical rod or optical taper is proximate to the substantially planar light-emitting surface, the other end of the optical rod or taper can be connected to a light guide. In some embodiments, a light post taper can be disposed between the optical rod or the optical taper and the light guide.

[0007] In another aspect, the invention is directed to a method of collimating light from a light source. The method includes attaching an optical rod or optical taper to a substantially planar light-emitting surface of the light source and activating the light source.

[0008] In another aspect, the invention is directed to a method of illuminating an object. The method includes providing a device including a light source having a substantially planar light-emitting surface and an optical rod or taper having a first end held proximate to the substantially planar light-emitting surface; positioning the device relative to the object; and activating the light source. In some embodiments, the optical rod or taper can include a second end attached to optics to transmit the light emitted from the light source through the optical rod or taper to the object.

[0008a] In a further aspect, the present invention provides an illumination device comprising: a light source including a substantially planar light-emitting surface, an optical taper including a light receiving end and a second end, the light receiving end having a smaller surface area than the second end and the light receiving end matching an area of the substantially planar light-emitting surface; and a light post taper; wherein the light receiving end of the optical taper is disposed proximate to the substantially planar light-emitting surface to optically couple the optical taper and the substantially planar light-emitting surface, and the second end of the optical taper is proximate to the light post taper.

[0009] Any of the above implementations can realize one or more of the following advantages. The illumination devices and methods described above are efficient at transmitting light from the light source into the optical rod or optical taper. As a result, objects can be illuminated with a proper amount of light (e.g., object is visible under endoscopic examination; object under a lamp is sufficiently lighted for viewing purposes). Another advantage realized in the above embodiments is that the optical rod or optical taper can be coupled to the light source without the use of additional optical components or auxiliary optics, such as, for example, mirrors, lenses, reflectors. As a result, a large amount of the light emitted by the light source can be coupled directly into the optical rod or optical taper, thereby allowing a greater amount of light from the light source to be transmitted to the objects under investigation. The lack of auxiliary optics between the light source and the optical rod or taper also simplifies the

- 4a -

mechanical design and size of the illumination device. In addition, the high light output and high coupling efficiency of the light emitted by the light source into the optical rod or optical taper increases battery lifetime and thus permits the use of smaller capacity, and smaller volume batteries to power the illumination device.

-5-

BRIEF DESCRIPTION OF THE DRAWINGS

[0010] The foregoing and other features and advantages of the present invention, as well as the invention itself, will be more fully understood from the following description of various embodiments, when read together with the accompanying drawings.

[0011] FIG. 1 is an illustration of a prior art illumination device including a LED-based light source.

[0012] FIG. 2 is an illustration of an illumination device including a substantially planar light-emitting surface in accordance with the present invention.

[0013] FIG. 3 is an illustration of another embodiment of an illumination device including a substantially planar light-emitting surface in accordance with the present invention.

[0014] FIG. 4 is an illustration of another embodiment of an illumination device including a substantially planar light-emitting surface in accordance with the present invention.

[0015] FIG. 5 is an illustration of another embodiment of an illumination device including a substantially planar light-emitting surface in accordance with the present invention.

[0016] FIG. 6 is an illustration of another embodiment of an illumination device including a substantially planar light-emitting surface in accordance with the present invention.

[0017] FIG. 7 is an illustration of the illumination device of FIG. 6 disposed within a handle of an endoscope.

[0018] FIG. 8 is an illustration of another embodiment of an illumination device including a substantially planar light-emitting surface in accordance with the present invention.

-6-

DETAILED DESCRIPTION

[0019] Prior art illumination devices, such as, for example, the illumination device shown in FIG. 1, include a light source 5 having a dome-shaped lens 10 optically coupled to transmission media 15. With this coupling arrangement, light is ineffectively transmitted to the transmission media 15 because the light emitting portion 20 of the light source 5 is not sufficiently close to the transmission media 15 (i.e., due to the curvature of the dome lens 10, the light emitting portion 20 is spaced at an unacceptable distance away from the transmission media). In addition, the dome shape lens 10 provides a convex light-emitting surface. As a result, a portion of the light passing through an interface between the light source 5 and the transmission media 15 is lost, thereby decreasing the light strength and efficiency of conventional illumination devices.

[0020] Illumination devices of the present invention include a substantially planar light-emitting surface which is proximate to either an optical rod or an optical taper. As a result, a greater amount of light is transmitted from the light source to the optical rod or taper than in prior art systems.

[0021] In accordance with one embodiment of the invention, an illumination device 50 shown in FIG. 2 includes a LED 55, such as, for example, a high power LED (Luxeon III Model LXHL-LW3C, Lumileds Lighting, San Jose, CA) and an optical rod 60. A dome lens, such as the dome lens 10 shown in FIG. 1, and any index matching material surrounding the LED 55 was not employed or was removed prior to coupling the LED 55 to the optical rod 60. As a result, the substantially planar light-emitting surface 65 of the LED 55 (e.g., the surface of a light-emitting chip in the LED 55) is proximate to a first end 70 of the optical rod 60. The substantially planar light-emitting surface 65 and the first end 70 together form a planar interface in which light can be transmitted with less light loss than in an interface including a curved or convex surface.

-7-

[0022] The coupling arrangement of the light source 55 and the optical rod 60 provides many advantages to the illumination device 50 over prior art systems. Besides an increase in the amount of light transmitted through the illumination device, the coupling arrangement shown in FIG. 2 provides light source protection and mechanical stability to the illumination device 50. Specifically, the optical rod 60 protects the LED 55 from the external environment and also provides an additional advantage of being a rugged element to which additional elements of the illumination device can be easily coupled to. For example, referring to FIG. 3, a light guide bundle 80 formed of a plurality of optical fibers and held together by a ferrule 85 can easily be attached to the optical rod 60 without fear of damaging the light-emitting diode.

[0023] The substantially planar light-emitting surface 65 of the LED 55 is the top surface of the LED chip. In some embodiments, the substantially planar light-emitting surface 65 can further include a coating of a substance that emits white light or one or more specific colors of light when activated. For example, the substantially planar light-emitting surface 65, in certain embodiments, includes a phosphor film or coating on the top surface of the LED 55. In other embodiments, such as the embodiments shown in FIG. 4, the substantially planar light-emitting surface 65 can be formed of a transparent flat window placed over the LED 55. In this embodiment, light is emitted from the top surface of the LED 55 and then through the transparent window. The flat window is proximate to the optical rod 60 and forms a planar interface with the optical rod.

[0024] Optical rod 60 can be formed from a transparent material or any material which allows light to pass through. Examples of materials that can be used to form the optical rod include glass, plastic, and sapphire. In addition, the optical rod can be a clad rod, a silvered rod, an aluminized rod, or formed from a plurality of fibers (e.g., fiber bundle).

[0025] Referring to FIG. 5, illumination device 150 includes LED 55 and an optical taper 160 positioned proximate to the substantially planar light-emitting surface 65 of the LED 55.

-8-

Optical taper 160 is formed from any transparent material such as, for example, glass or plastic and has a first end or a smaller surface area end 162 and a second end or a larger surface area end 164. The optical taper 160 can be made from a solid rod of transparent material that is drawn down to a smaller diameter or profile at one end or, in other embodiments, the optical taper can be formed from a plurality of fibers (e.g., a fiber taper) that are also drawn down in diameter or profile. The optical taper 160 provides the advantage of resizing and reshaping the output of the light from the light source (e.g., LED 55). For example, a typical LED die is about 1mm x 1mm square that emits over a broad angular cone. Employing a high index of refraction transparent material, such as, for example glass or plastic, in the taper 160 produces a high acceptance angle of light at the first end or smaller surface area end 162 of the taper. The larger surface area end 164 of the taper exhibits a reduction in the numerical aperture (NA) by the ratio of the end diameters. For example, a 1:3 taper made from glass has an angular aperture at the first end 162 of 123 degrees and a numerical aperture of 0.88 NA. The second end 164 of the taper has a numerical aperture of 0.29 NA and an angular aperture of 34 degrees. As a result, the taper 160 provides a number of advantages to the illumination device 150. For example, in the embodiment shown in FIG. 5, the taper 160 collects a very large solid angle of light emitted by the LED 55 because of the high NA at the first end 162 of the taper. The taper 160 protects the LED 55 from the environment. The taper 160 collimates the light as it passes through the taper 160 and delivers the light in a manner that is more readily coupled to light guides. The taper 160 presents a lower dispersion of light to additional optics should imaging or collection of the light be necessary for a particular application, such as, for example, spot light imaging in a museum or projection of a transparency image. In addition, the taper 160 provides mechanical stability to illumination device 150 and is a rugged element to which additional elements of the illumination device can be easily coupled to.

-9-

[0026] While the taper 160 as shown in FIG. 5 has its first end 162 in direct contact with the LED 55, other resizing and reshaping arrangements are available. For example, instead of the small surface area end 162 being in contact with the planar light-emitting surface 65 of the LED 55, the larger surface area 164 can be in contact with the light-emitting surface 65. This embodiment allows for a smaller angle of light to be collected from the LED but provides a greater dispersion of light emitted from the taper 160.

[0027] Referring to FIG. 6, the illumination device 150 can be combined with a light guide bundle 200 including a light post taper 210. The illumination device 150 can be used as the light source for an endoscope. The light from the LED 55 is emitted through the illumination device 150 and is collected by the light post taper 210, which is adhered to the fiber optic light guide bundle 200. The light guide bundle 200 transmits the light to a remote location, such as, for example, through the body of the endoscope to illuminate an object under inspection. In general, the light post taper 210 selected for use with the illumination device 150 and the light guide bundle 200 has a first end or light receiving end 215 that has a surface area size comparable to the second end of the taper 160 and a second end or a light transmitting end 220 that has a surface area size comparable to the size of the connection end 230 of the light guide bundle 200.

[0028] In certain embodiments, the illumination device 150 can be positioned within a housing. Referring to FIG. 7, illumination device 150 is within a detachable light source housing 300 including a connector 310 to couple the illumination device 150 to a light guide post taper 210 surrounded by a light post 250. The illumination device 150, including the LED 55 having a light-emitting surface 65 proximate to taper 160, is inserted into a recess within the detachable housing 300. The light post 250 mates with one end of the detachable housing so that the light post taper 210 comes into direct contact with the taper 160 of the illumination device.

-10-

[0029] The optical taper 160 and the light post taper 210 can be selected for use with the illumination device 150 to increase the amount of light transmitted from the illumination device into the light guide bundle 200. For example, in an embodiment in which the optical taper 160 has a 1:3 ratio of end areas, with the small surface area end 162 having a 1.0 NA and a large surface area end 164 having a 0.33 NA, the collection angle at the small surface area end 162 is 180 degrees. The 1:3 ratio of end diameters cause the output NA to decrease to 0.33. In other words, the light exiting the larger surface area end 164 has an angular aperture of approximately 39 degrees. As a result, the light initially emitted by the LED 55 over the 180 degrees exits the taper 160 contained in a 39 degree cone at the larger surface area end 164. In the present embodiment, the light post taper 210 located proximate to the larger surface area end 164 is made of 0.66 NA glass and has a 2:1 diameter ratio. As a result, the larger surface area end 215 of the light post taper 210 receives light over about a 39 degree angle, a near perfect match to the light transmitted from the larger surface area end 164 of the optical taper 160. The light entering the light post taper 210 is reduced in diameter by a factor of 2, with a resulting increase in numerical aperture to 0.66 NA and an exit cone angle of 83 degrees for the light exiting the smaller surface area end 220 of the light post taper 210. Adhered directly to the smaller surface area end 220 of the light post taper 210 is the light guide bundle 200 formed of 0.66 NA glass, which has an acceptance angle (e.g., 83 degrees) that substantially matches the exit angle of the light post taper 210 (e.g., 83 degrees).

[0030] The illumination devices described above can be used to illuminate objects. For example, by utilizing either device 50 or 150, light from a light source can be collimated and transmitted to illuminate an object. Specifically, by coupling an optical rod or optical taper to a substantially planar light-emitting surface of an LED and activating the LED, the light generated and dispersed by the LED is collimated and transmitted through the optical rod and taper to produce a collimated light beam that can illuminate objects. In certain embodiments, the device

-11-

50 or 150 can be disposed within a lamp. When the lamp is positioned relative to an object and the light source 55 within the lamp is activated, the lamp produces a spot light which illuminates the object.

[0031] While certain embodiments have been described, other embodiments are also possible. As an example, while LED 55 has been described as a chip 55 free from or removed completely from a dome lens, in some embodiments, such as the embodiment shown in FIG. 8, the LED 55 can remain in a modified or partially removed dome lens. Specifically, the dome lens 10 surrounding the LED 55 can be ground and polished nearly down to the level of the encapsulant-LED interface, so as to preserve the integrity of the mechanical package of the LED chip. After the dome lens has been partially removed, the planar light-emitting surface 65 of the LED 55 is accessible for connection to an end of the optical rod 60 or optical taper 160. To couple the optical rod or taper to the substantially planar light-emitting surface, a manufacturer positions an end of the rod or taper in a proximate relationship to the light-emitting surface 65. This process entails positioning the optical rod or taper as close as possible to the light-emitting surface 65 without damaging the light-emitting qualities of the LED 55. For example, in certain embodiments, the end of the rod or taper is in direct physical contact with the surface 65. In other embodiments, the end of the rod or taper is spaced a distance less than about 1 to 2 millimeters away from the surface 65. As a result, air, gas, adhesive, or an index matching material, such as, for example, a coupling gel may be disposed between the surface 65 and the end of the rod or taper within the 1 to 2 millimeter gap.

[0032] Variations, modifications, and other implementations of what is described herein will occur to those of ordinary skill without departing from the spirit and the scope of the invention. Accordingly, the invention is not to be defined only by the preceding illustrative description.

We claim:

1. An illumination device comprising:
 - a light source including a substantially planar light-emitting surface,
 - an optical taper including a light receiving end and a second end, the light receiving end having a smaller surface area than the second end and the light receiving end matching an area of the substantially planar light-emitting surface; and
 - a light post taper;wherein the light receiving end of the optical taper is disposed proximate to the substantially planar light-emitting surface to optically couple the optical taper and the substantially planar light-emitting surface, and the second end of the optical taper is proximate to the light post taper.
2. The illumination device of claim 1, wherein the substantially planar light-emitting surface comprises an emitting surface of a light-emitting diode chip.
3. The illumination device of claim 1, wherein the substantially planar light-emitting surface comprises a transparent substantially planar window disposed over an emitting surface of a light-emitting diode chip.
4. The illumination device of claim 1, wherein the light receiving end is in direct contact with the substantially planar light-emitting surface of the light source.
5. The illumination device of claim 1, wherein the second end is in direct contact with the substantially planar light-emitting surface of the light source.
6. The illumination device of claim 1, wherein an adhesive or an index matching material is disposed between the optical taper and the substantially planar light-emitting surface.
7. The illumination device of claim 1, wherein a gas is disposed between the optical taper and the substantially planar light-emitting surface.
8. The illumination device of claim 1, wherein the optical taper comprises a glass optical taper.

9. The illumination device of claim 1, wherein the optical taper comprises a plastic optical taper.
10. The illumination device of claim 1, wherein the light receiving end of the optical taper is proximate to the substantially planar light-emitting surface of the light source and the second end of the optical taper is proximate to a light guide.
11. The illumination device of claim 1, wherein a light receiving end of the light post taper is proximate to the optical taper and a light transmitting end of the light post taper is attached to a light guide.
12. The illumination device of claim 1 disposed within an endoscope.
13. The illumination device of claim 1 disposed within a lamp.
14. The illumination device of claim 1, further comprising a substance that emits light when the light source is activated, the substance being positioned between the substantially planar light-emitting surface and the optical taper.

1/5

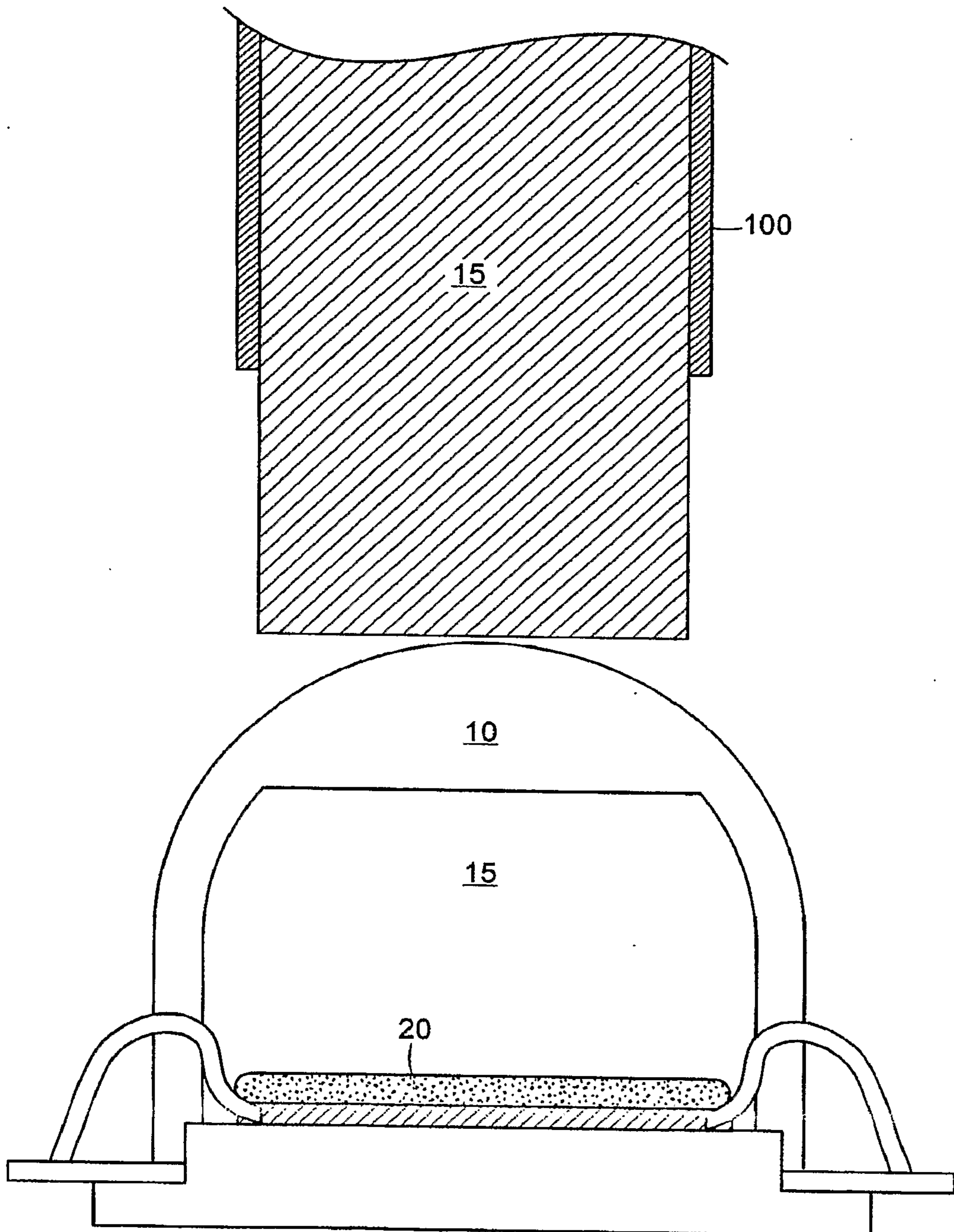

PRIOR ART
FIG. 1

2/5

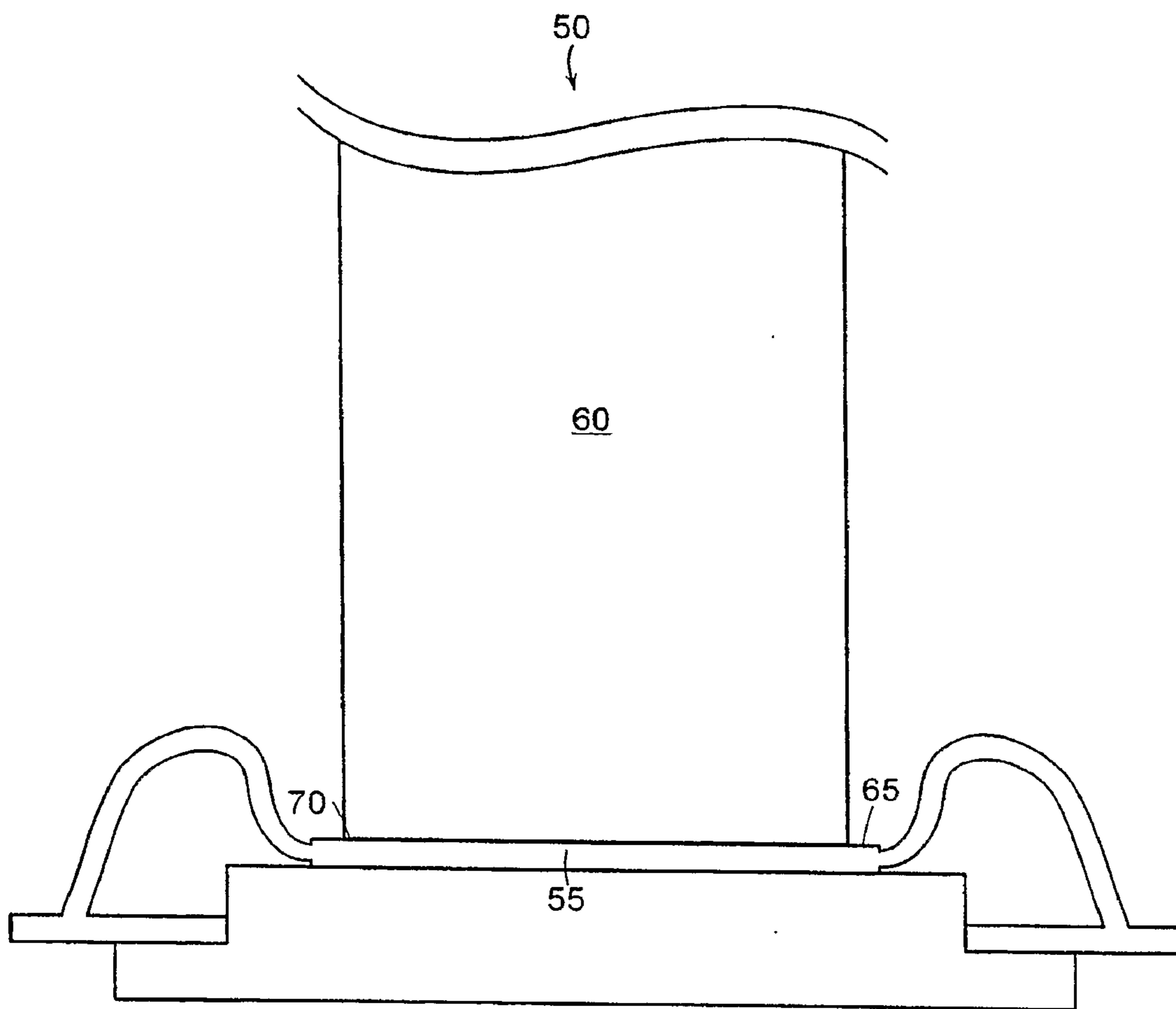

FIG. 2

3/5

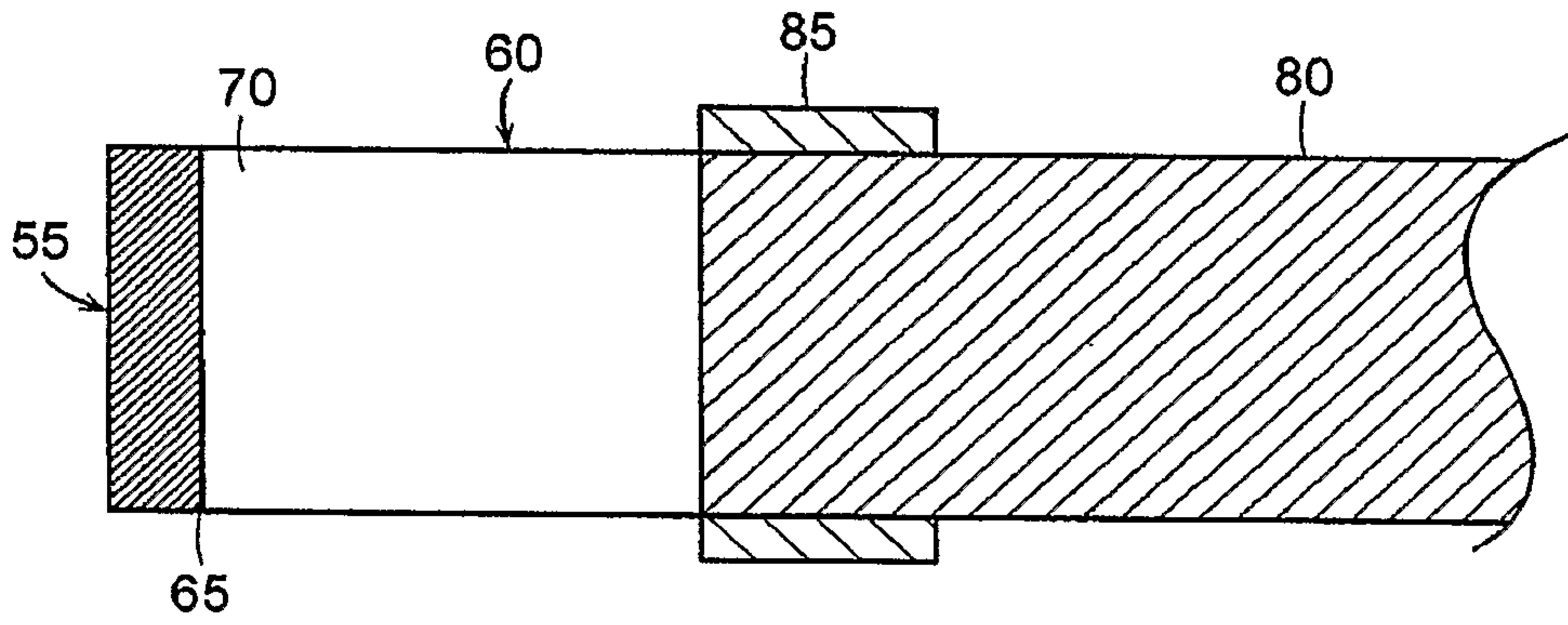

FIG. 3

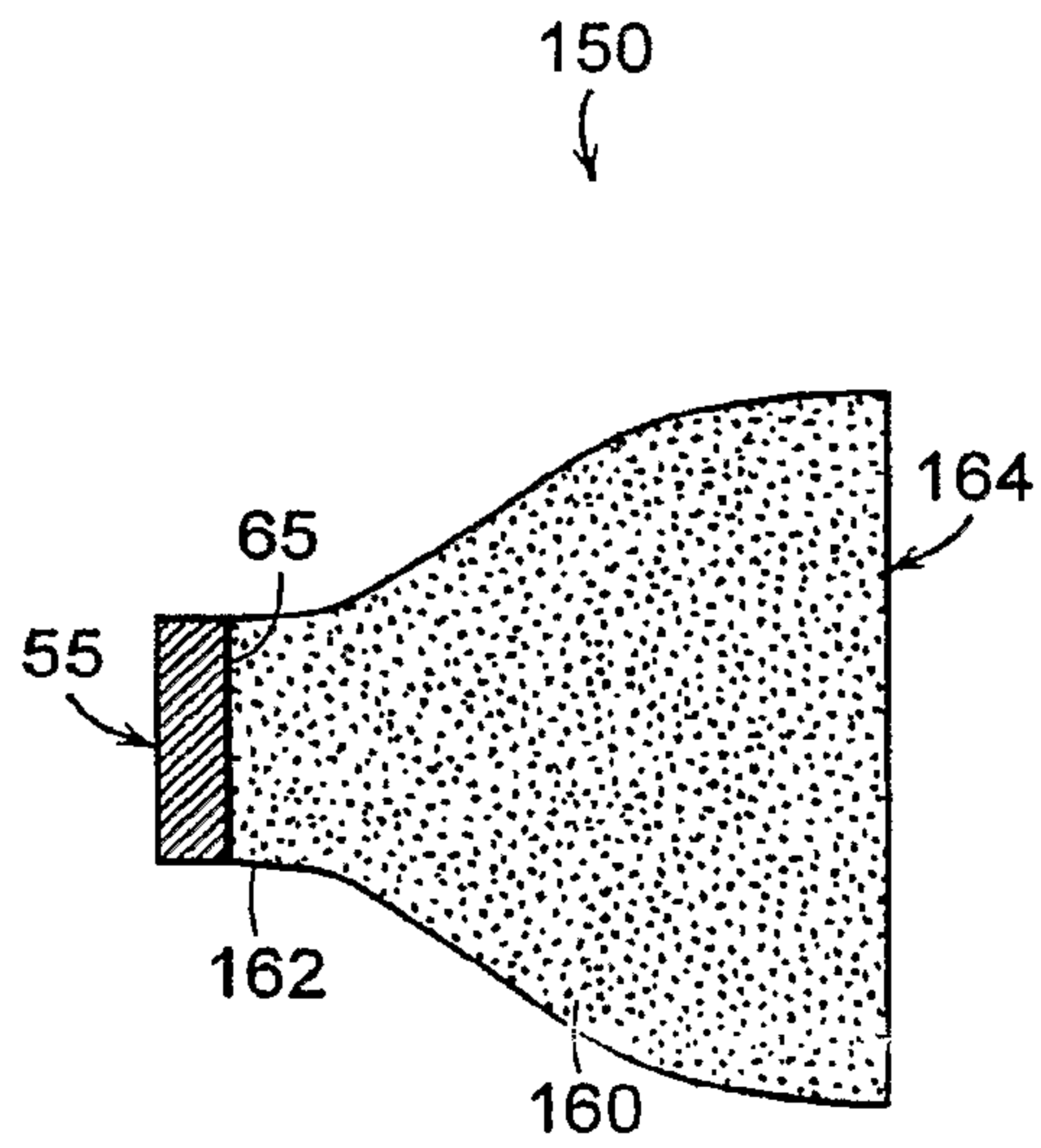

FIG. 5

4/5

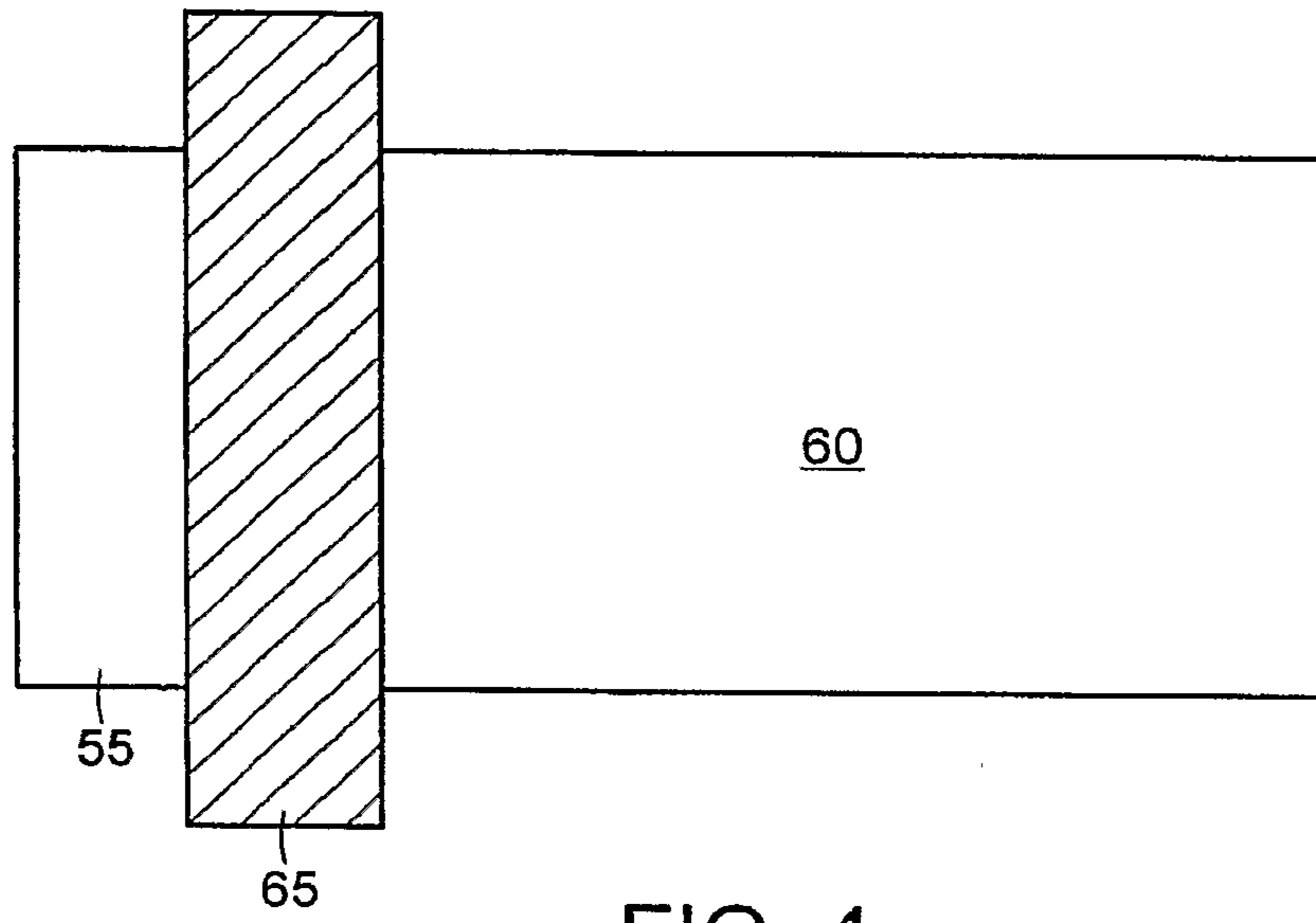

FIG. 4

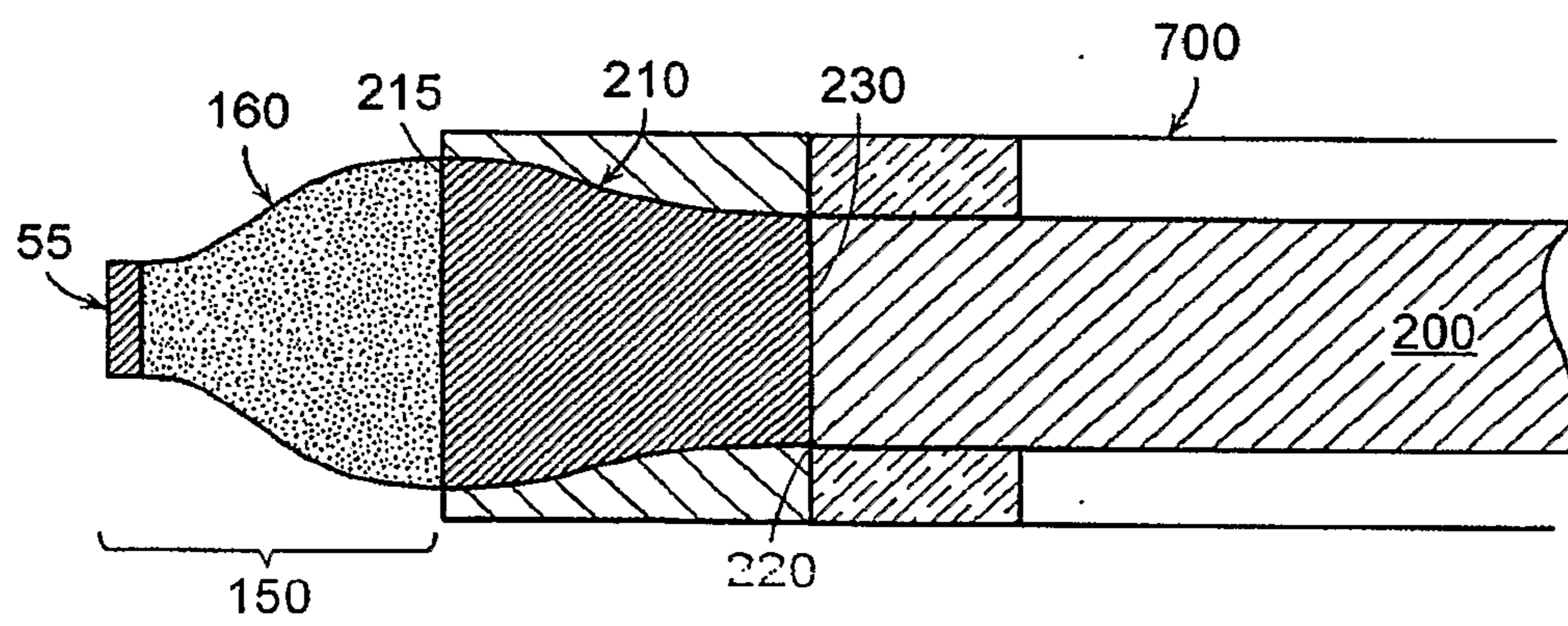

FIG. 6

5/5

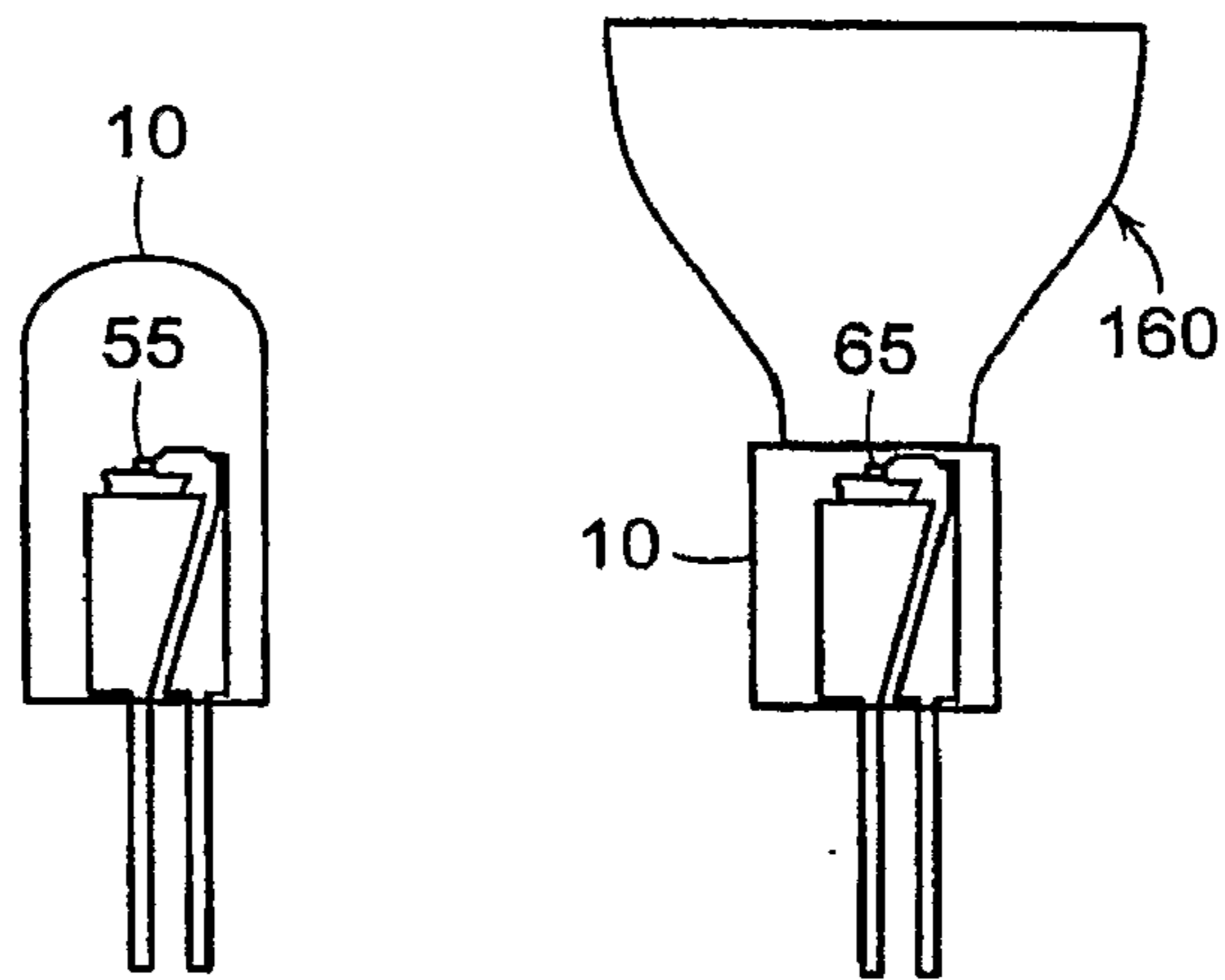

FIG. 8

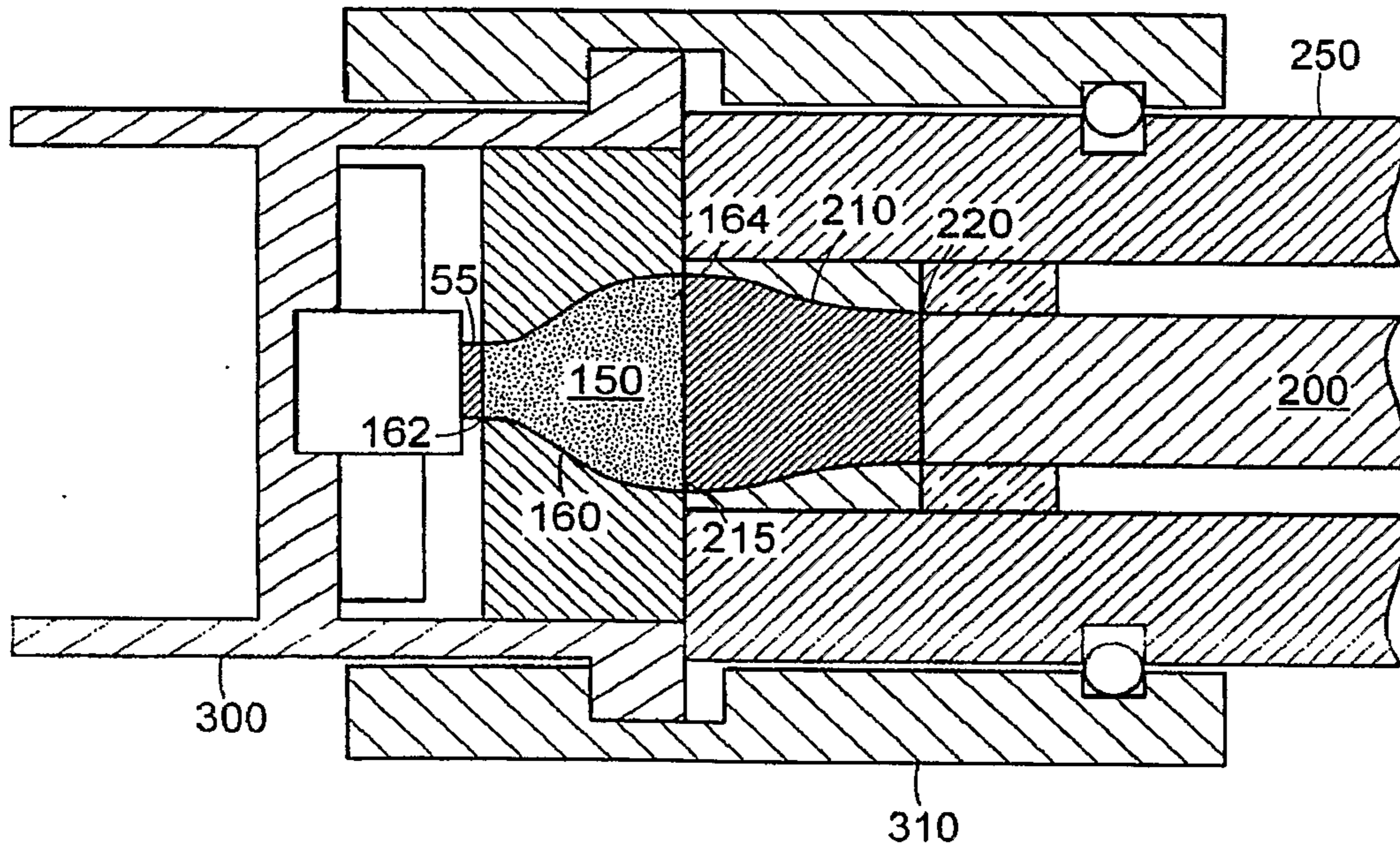

FIG. 7

