

(19) World Intellectual Property
Organization
International Bureau



(43) International Publication Date
24 March 2005 (24.03.2005)

PCT

(10) International Publication Number
WO 2005/026085 A2

- (51) International Patent Classification⁷: C07C 2/64, 15/073
- (21) International Application Number: PCT/US2004/028646
- (22) International Filing Date: 1 September 2004 (01.09.2004)
- (25) Filing Language: English
- (26) Publication Language: English
- (30) Priority Data: 10/660,065 8 September 2003 (08.09.2003) US
- (71) Applicant (for all designated States except US): **ABB LUMMUS GLOBAL INC.** [US/US]; 1515 Broad Street, Bloomfield, NJ 07003 (US).
- (72) Inventors; and
- (75) Inventors/Applicants (for US only): **HILDRETH, James, M.** [US/US]; 76 Barrett Lane, Wyckoff, NJ 07481 (US). **DUKANDAR, Kerman, Nariman** [US/US]; 96 Bernard Avenue, Edison, NJ 08837 (US). **VENNER, Ronald, M.** [US/US]; 862 Iron Latch Road, Franklin Lakes, NJ 07417 (US).
- (74) Agents: **CALDERONE, Adrian, T.** et al.; Dilworth & Barrese, LLP, 333 Earle Ovington Boulevard, Uniondale, NY 11553 (US).
- (81) Designated States (unless otherwise indicated, for every kind of national protection available): AE, AG, AL, AM, AT, AU, AZ, BA, BB, BG, BR, BW, BY, BZ, CA, CH, CN, CO, CR, CU, CZ, DE, DK, DM, DZ, EC, EE, EG, ES, FI, GB, GD, GE, GH, GM, HR, HU, ID, IL, IN, IS, JP, KE, KG, KP, KR, KZ, LC, LK, LR, LS, LT, LU, LV, MA, MD, MG, MK, MN, MW, MX, MZ, NA, NI, NO, NZ, OM, PG, PH, PL, PT, RO, RU, SC, SD, SE, SG, SK, SL, SY, TJ, TM, TN, TR, TT, TZ, UA, UG, US, UZ, VC, VN, YU, ZA, ZM, ZW.
- (84) Designated States (unless otherwise indicated, for every kind of regional protection available): ARIPO (BW, GH, GM, KE, LS, MW, MZ, NA, SD, SL, SZ, TZ, UG, ZM, ZW), Eurasian (AM, AZ, BY, KG, KZ, MD, RU, TJ, TM), European (AT, BE, BG, CH, CY, CZ, DE, DK, EE, ES, FI, FR, GB, GR, HU, IE, IT, LU, MC, NL, PL, PT, RO, SE, SI, SK, TR), OAPI (BF, BJ, CF, CG, CI, CM, GA, GN, GQ, GW, ML, MR, NE, SN, TD, TG).

[Continued on next page]

(54) Title: PROCESS FOR PRODUCTION OF ETHYLBENZENE FROM DILUTE ETHYLENE STREAMS

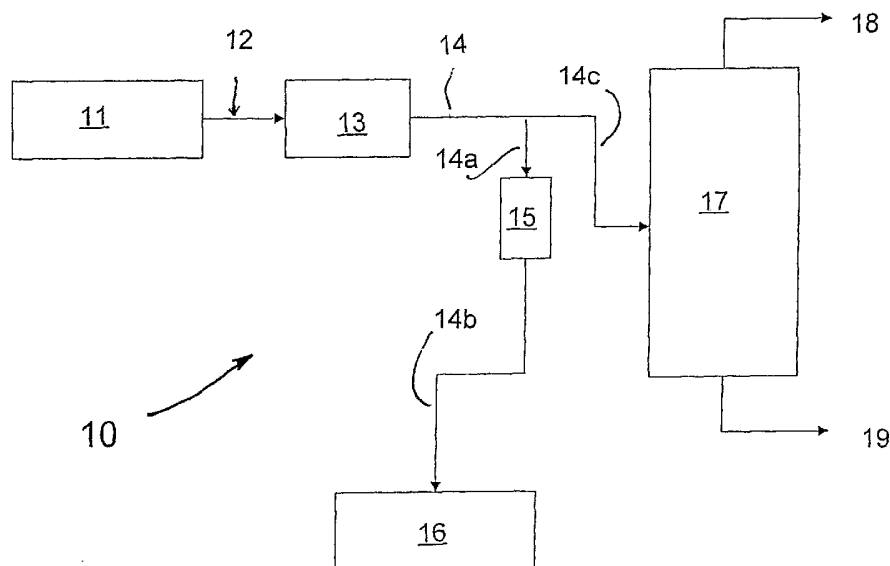

(57) Abstract: An improvement in a process for the production of ethylbenzene from a dilute ethylene stream wherein an ethylene-containing stream derived from a cracking process is directed to an ethylene fractionator for separation of ethylene and ethane. The improvement includes providing the dilute ethylene stream by liquefying and separating out a portion of the ethylene-containing stream prior to directing the remainder of the ethylene-containing stream to the ethylene fractionator and/or by drawing off a side stream from the ethylene fractionator; and, directing the dilute ethylene stream as a feed to an alkylator for alkylation with benzene to produce ethylbenzene.

WO 2005/026085 A2



Published:

- *with international search report*
- *before the expiration of the time limit for amending the claims and to be republished in the event of receipt of amendments*

For two-letter codes and other abbreviations, refer to the "Guidance Notes on Codes and Abbreviations" appearing at the beginning of each regular issue of the PCT Gazette.

PROCESS FOR PRODUCTION OF
ETHYLBENZENE FROM DILUTE ETHYLENE STREAMS

5

BACKGROUND OF THE INVENTION

Field of the Invention

[1] The invention relates to processes related to the production of ethylbenzene from dilute sources of ethylene.

10

Description of the Related Art

[2] Ethylene is a commonly used unsaturated organic compound which may be used in various processes for the synthesis of more complex compounds. For example, ethylene can be reacted with aromatics to produce alkylaromatics, such as ethylbenzene, and with butenes to produce propylene. Ethylbenzene is commonly used to produce styrene, which may be polymerized to produce polystyrene. Propylene is commonly used for the manufacture of polypropylene.

15

[3] The process for producing high purity ethylene is well known, and involves pyrolysis of a hydrocarbon feed and subsequent separation of ethylene and reaction by-products by distillation. The process generally comprises the following: A feedstock comprising

20

ethane, propane, butane, naphtha, gas oils or hydrocracked vacuum gas oils is fed to an ethylene plant, where it is thermally cracked in the presence of steam in a bank of pyrolysis furnaces. An olefin-bearing effluent gas is formed and is quenched progressively by generating steam and through direct contact with oil and/or water. The effluent is compressed in a multi-stage centrifugal compressor, acid gases are removed by amine treating and/or a caustic wash, and then the gases are dried over a molecular sieve. Methane offgas is recovered under cryogenic conditions in a demethanizer. Ethylene and ethane are then recovered together in a deethanizer. Acetylene is normally catalytically removed and then an ethylene product recovery takes place under low temperature conditions in a final fractionation column. Just prior to final fractionation the ethylene stream will include significant amounts of ethane (15% to [4] 35 %) and relatively small amounts of hydrogen, methane and propylene. Final fractionation results in a high purity (polymer-grade) ethylene (at least about 99.95 mol%) and recycle ethane, which may be used to produce more ethylene. Variations of this scheme also exist including schemes where the deethanization, depropanization and/or acetylene removal steps may

precede the demethanization step. In all cases a final fractionation of ethylene-ethane is employed to produce high purity ethylene product.

[5] The final fractionation of the ethylene mixture is relatively energy intensive and it would be preferable to reduce the amount of ethylene/ethane processed in this manner, or to eliminate this step altogether. However, many processes, including those to produce propylene and ethylbenzene, typically are carried out with a feed of high purity ethylene. Ethylene streams diverted from the ethylene plant, after acetylene removal but before final fractionation, typically contain only about 65 mol% ethylene when ethane crackers are the source of the ethylene, and about 85 mol% ethylene when naphtha crackers are the source of the ethylene; the primary difference between the two processes being the feedstock used and a somewhat simpler recovery section for the ethane cracker (i.e., the ethane cracker has fewer distillation columns since heavy byproduct formation is reduced).

[6] A number of processes for producing alkylaromatics, such as ethylbenzene, are also known, and may employ fixed-bed or catalytic distillation type processes. The fixed-bed process generally comprises the following: Benzene is sent to an alkylator

containing a fixed bed of alkylation catalyst and reacted with ethylene to yield a mixture of alkylated benzenes and excess benzene. The mixture is fractionated to recover ethylbenzene, recycle benzene, and higher ethylated benzenes. The recycle benzene is sent back to the alkylator to react with additional ethylene and to a transalkylator, where the higher ethylated benzenes are transalkylated with the benzene to form additional ethylbenzene.

10 [7] While polymer-grade ethylene is preferable for these processes, ethylbenzene can also be produced from relatively dilute ethylene feeds. In this event, catalytic distillation reactors are preferred because ethylene feeds as dilute as about 15 mol% can be
15 utilized to produce ethylbenzene. If the fixed-bed process is used with dilute ethylene feeds, ethylene with a purity as low as about 60 mol% can be used, provided the remaining 40 mol% of the feed contains minimal hydrogen and methane content. Dilute ethylene
20 from an ethane cracker may have relatively low amounts of methane and hydrogen, but this may not always be the case since, for example, dilute ethylene from an ethylene plant with a front-end deethanizer may contain larger quantities of hydrogen and methane.

Alternatively, dilute ethylene from a fluid catalytic cracker (FCC) may contain very large quantities of hydrogen or methane if they are not separated at a FCC vapor recovery unit by compression and distillation of FCC off-gas. Typically, the ethane and lighter gases from the FCC do not undergo further separation - rather they are sent to a fuel gas system in the refinery. In any event, fixed-bed processes will incur an energy penalty when the ethylene feed purity is below about 83 mol%.

[8] The energy penalty includes additional energy which must be used in the ethylbenzene plant when ethylene sources used are very dilute. For example, in the ethylbenzene plant described above, additional energy may be needed to recover aromatics from vent gases. Such additional processing may involve refrigerated vent condensers and/or an absorption/stripping system with reboilers and condensers.

[9] The advantages of the invention include significant energy, and consequently cost, savings by eliminating or reducing the final fractionation of ethylene in the ethylene plant.

SUMMARY

[10] An improved process is provided herein for the production of ethylbenzene from a dilute ethylene stream wherein an ethylene-containing stream derived from a cracking process is directed to an ethylene fractionator for separation of ethylene and ethane. The improvement comprises (a) providing the dilute ethylene stream by (i) liquefying and separating out a portion of the ethylene-containing stream prior to directing the remainder of the ethylene-containing stream to the ethylene fractionator and/or by (ii) drawing off a side stream from the ethylene fractionator; and, (b) directing said dilute ethylene stream as a feed to an alkylator for alkylation with benzene to produce ethylbenzene.

[11] The process advantageously saves costs by reducing the amount of energy required for ethylene fractionation.

20 BRIEF DESCRIPTION OF THE DRAWINGS

[12] Various embodiments are described below with reference to the drawings wherein:

[13] FIG. 1 is a schematic diagram illustrating an ethylbenzene process of the invention wherein a dilute ethylene stream is provided by condensing a portion of

an ethylene-containing stream to form a dilute ethylene liquid stream which is sent to an alkylator;

[14] FIG. 2 is a schematic diagram illustrating an ethylbenzene process of the invention wherein an ethylene-containing stream is partially condensed to form a dilute ethylene liquid which is sent to an alkylator;

[15] FIG. 3 is a schematic diagram illustrating an ethylbenzene process of the invention wherein a dilute ethylene stream is taken as a side draw from the stripping section of an ethylene fractionator;

[16] FIG. 4 is a schematic diagram illustrating an ethylbenzene process of the invention wherein a dilute ethylene stream is taken as a side draw from the rectification section of an ethylene fractionator; and

[17] FIG. 5 is a schematic illustration of a process for producing ethylbenzene from ethylene and benzene.

DETAILED DESCRIPTION OF THE PREFERRED EMBODIMENTS

[18] The invention relates to processes for producing dilute ethylene, and using the dilute ethylene to produce ethylbenzene. Dilute ethylene streams from cracking processes typically contain from about 60 mol % to about 85% ethylene with the remainder being mostly ethane with minor amounts of methane and/or hydrogen.

[19] While individual processes for producing ethylene, and ethylbenzene are known, the present invention combines the processes in a manner which is designed to improve overall efficiency and, consequently, reduce the total costs associated with the production of ethylbenzene.

[20] Generally, preferred processes of the invention comprise diverting a dilute ethylene stream from an ethylene plant at a point subsequent to acetylene removal. The ethylene plant includes the cracking of a hydrocarbon feed such as ethane, propane, butane, naphtha, gas oil, hydrocracked vacuum gas oil and combinations thereof.

[21] In one embodiment the method of the present invention provides dilute ethylene for the production of ethylbenzene wherein a dilute ethylene stream containing ethylene and ethane is withdrawn from the ethylene plant at a point downstream of acetylene removal and upstream of final ethylene product fractionation. The ethylene content of the dilute ethylene feed is at least about 60 mol%. By withdrawing dilute ethylene from the effluent of the acetylene remover and before the final fractionation step, significant capital and energy saving can be achieved in the ethylene plant because the

ethylene/ethane mixture sent to the ethylbenzene plant does not need to be fractionated, thereby saving the fractionation energy. Dilute ethylene can be supplied by subjecting the entire effluent of the acetylene
5 remover to a cooling process in which part of the effluent is condensed to a liquid, or fully condensing only a portion of the effluent. Partial condensing produces a slightly more dilute feed to the ethylbenzene plant and enriches the remaining stream
10 sent as feed to the ethylene fractionator. Fully condensing only a portion of the effluent has the advantage of producing the richest ethylbenzene feed (about 83% for a typical naphtha cracker). Savings are achieved by reducing the ethylene/ethane processed in
15 the ethylene fractionator. In the case of partial condensation, some savings in reflux are also achieved due to feed enrichment. These two cases are detailed below.

[22] In another embodiment the dilute ethylene stream
20 is withdrawn from the ethylene plant as a side draw from the ethylene fractionation column. By withdrawing dilute ethylene as a side-draw from the final fractionation step, significant capital and energy savings can be achieved in the ethylene plant because
25 the ethylene/ethane mixture sent to the ethylbenzene

plant does not need to be fully fractionated, thereby saving the fractionation energy. Side-draw can be taken as a liquid or vapor from either the stripping or rectification section. If taken from the rectification section, dilute ethylene of at least 83% purity can be readily produced, thereby eliminating any energy penalty in the ethylbenzene plant. These cases are summarized below.

[23] The dilute ethylene streams are then sent to an alkylator for alkylation with benzene to produce ethylbenzene. Various processes for the production of ethylbenzene from the alkylation of ethylene and benzene are known. Suitable processes for the alkylation of dilute ethylene streams are set forth in commonly assigned copending patent applications Serial Nos 10/372,449 filed February 25, 2003 and 10/376,683 filed February 28, 2003, both of which are incorporated by reference herein in their entirety.

[24] Referring now to FIG. 1, a process 10 for the production of ethylbenzene from a dilute ethylene stream is shown. More particularly, the deethanizer 11 of a conventional ethylene plant provides a C₂ vapor stream 12 containing ethylene, ethane and acetylene, which is then sent to an acetylene removal unit 13 for the removal of acetylene preferably by partial

hydrogenation in a catalytic reactor to form more ethylene. Optionally, unit 13 can alternatively be an acetylene recovery unit which separates out acetylene rather than converting it. The resulting effluent stream 14, containing at least about 60 mol% ethylene is then divided into a dilute ethylene stream 14a and a remainder 14c of the ethylene-containing steam which is directed to the ethylene fractionator 17 as a feed. The ethylene fractionator 17 separates the ethylene-containing stream 14c into a high purity ethylene fraction 18 (at least about 99.95 mol% pure ethylene) and an ethane fraction 19. The ethane is preferably recycled to the cracking units. The dilute ethylene stream 14a containing at least about 60 mol% ethylene is sent to a condenser 15 wherein stream 14a is totally condensed to liquid stream 14b, which is then sent to a conventional ethylbenzene process 16. The amount of dilute ethylene stream 14a drawn off from the acetylene reactor effluent 14 depends upon the ethylene requirements for the ethylbenzene process. In this case the ethylene content of the dilute ethylene stream 14b is the same as the ethylene content of the ethylene fractionator feed 14c. The high purity ethylene stream 18 from the ethylene fractionator 17 can be used for polymerization processes, alkylation processes, or any

process where high purity ethylene is required, as well as those in which dilute ethylene can be employed.

[25] Referring to FIG. 2 an alternative embodiment 20 of the method of the present invention is illustrated wherein a C₂ vapor stream 22 from deethanizer 21 is sent to an acetylene removal unit 23 for the removal of acetylene by partial hydrogenation or acetylene recovery. The entire resulting effluent stream 24 is sent to a cooler 25 wherein a part of the ethylene-containing stream is condensed to a liquid dilute ethylene stream 24a which is then sent to a conventional ethylbenzene process 26. The remaining cooled but uncondensed portion 24b of the ethylene-containing effluent stream is sent as a vapor to ethylene fractionator 27 for separation into an overhead high purity ethylene stream 28 and bottom ethane stream 29. In this case the uncondensed portion 24b of the ethylene-containing stream is richer in ethylene content than the dilute ethylene stream 24a.

[26] Referring now to FIG. 3, yet another embodiment 30 of the present invention is illustrated wherein a C₂ vapor stream 32 from a deethanizer 31 is sent to an acetylene removal unit 33 for the removal of acetylene by partial hydrogenation or acetylene recovery. The resulting effluent stream 34 is sent to ethylene

fractionator 37 for separation into an overhead high purity ethylene stream 38 and an ethane bottoms 39. A liquid or vapor stream 35 of dilute ethylene is drawn from the side of the stripping portion ethylene fractionator at point 37a, and is then sent to the ethylbenzene process 36. The point 37a at which the dilute ethylene is withdrawn from the ethylene fractionator may be the feed tray or one or two trays below the feed tray such that the ethylene content of the sidedraw is at least about 60 mol%. The actual location will vary depending on the ethylene fractionator feed composition. The amount of liquid or vapor drawn off depends upon the ethylene requirements of the ethylbenzene process.

15 [27] Referring to FIG. 4, yet another embodiment 40 of the invention is shown wherein a C₂ vapor stream 42 from a deethanizer 41 is sent to an acetylene removal unit 43 for the removal of acetylene by partial hydrogenation or acetylene recovery. The resulting effluent stream 44 is then sent to ethylene fractionator 47 for separation into an overhead high purity ethylene stream 48 and an ethane bottoms 49. A liquid or vapor stream 45 of dilute ethylene is drawn from the side of the ethylene fractionator rectification section at point 47a and is then sent to

the ethylbenzene process 46. The point 47a at which the dilute ethylene is withdrawn from the ethylene fractionator may be ten to fifteen trays above the feed tray such that the ethylene content of the sidedraw is at least about 82 mol%. The actual location will vary depending on the ethylene fractionator feed composition. The amount of liquid or vapor drawn off depends upon the ethylene content of the stream 45 and the ethylene requirements of the ethylbenzene process.

5
10 [28] Referring now to FIG. 5 a process for producing ethylbenzene by the alkylation of benzene with ethylene is illustrated in a schematic diagram wherein ethylbenzene process 100 receives a dilute ethylene feed E such as that provided from the process described above (e.g., streams 14b, 24a, 35, and 45 in FIGS. 1 to 15 4), which is fed into alkylator 110 along with benzene feed B. The overhead from the alkylator 110 is sent to fractionator 130 from which a benzene overhead 131 is recycled back to the alkylator 110 and transalkylator 20 120. The bottoms 132 from fractionator 130 is sent to fractionator 140. The overhead 141 from fractionator 140 is an ethylbenzene product P. The bottom stream 142 from fractionator 140 are sent to fractionator 150. The overhead 151 from fractionator 150 contains

polyethylbenzene which is recycled back to the
transalkylator 120 for conversion to ethylbenzene. The
bottom stream 152 includes a heavy end fraction. The
product ethylbenzene P can be sent to further
5 processing for conversion to styrene monomer. The
heavy ends 152 can be used as fuel.

[29] Various aspects of the invention are illustrated
by the Examples given below.

Example 1

10 [30] In a system such as that illustrated in FIG. 1, a
portion of the effluent 14 is drawn off as dilute
ethylene stream 14a which is totally condensed to
produce a liquid equivalent to the amount of ethylene
required for ethylbenzene production and is sent to
15 ethylbenzene plant 16 as a liquid stream 14b. The
remaining stream 14c is sent to the ethylene
fractionator 14 as a vapor. This case reduces the feed
to the ethylene fractionator 17. Energy is saved in
the ethylene fractionator 17 but partly lost in the
20 form of lower recuperation from ethane recycle and in
the form of higher reflux requirements in the
deethanizer 11 to reduce the propylene content of the
deethanizer overhead (dilute ethylene). Propylene
content of the dilute ethylene must be sufficiently low
25 to prevent the excessive formation of cumene in the

ethylbenzene unit. Cumene, if formed, will be present as an impurity in the ethylbenzene product and is typically limited to 500 ppm or less. The purity of the ethylene feed, 14b in this case is about 80 mol% to about 83 mol%. The operating cost savings for a 950,000 kta ethylene plant combined with a 550,00kta ethylbenzene plant are estimated to be about \$560,000 per annum at current energy price levels.

Example 2

10 [31] In a system such as that illustrated in FIG. 2, the effluent 24 is sent to condenser 25 where it is partially condensed. The liquid equivalent to the amount of ethylene required for ethylbenzene production is sent to the ethylbenzene plant 26 via line 24a. The 15 chilled but uncondensed portion of the effluent 24 is sent to the ethylene fractionator as a vapor via line 24b. In this case the feed to the ethylene fractionator is both reduced as well as enriched. Energy is saved in the ethylene fractionator but is 20 partly lost in the form of lower recuperation from ethane recycle and in the form of higher reflux requirements in the deethanizer 21 to reduce the propylene content of the deethanizer overhead (dilute ethylene). The purity of the ethylene feed 24a to the 25 ethylbenzene plant 16 in this case is about 72 mol% to

about 78 mol%. The purity level is expected to cause reduced steam production in the ethylbenzene plant. However, without considering the impact in the ethylbenzene plant the savings in operating costs for a 950,000 kta ethylene plant combined with a 550,000 kta ethylbenzene plant are estimated to be about \$580,000 per annum at current energy price levels.

Example 3

[32] In a system such as that illustrated in FIG. 3, the entire effluent 34 from the acetylene converter 33 is sent to the ethylene fractionator 37 and the dilute ethylene feed to the ethylbenzene plant 36 is drawn off via stream 35 as a vapor from the stripping portion of the ethylene fractionator 37. Energy is saved in the ethylene fractionator 37 but is partly lost in the form of lower recuperation from ethane recycle and in the form of a higher reflux requirements in the deethanizer 31 to reduce the propylene content of the deethanizer overhead (dilute ethylene). The purity of the dilute ethylene stream 35 is about 60 mol% to about 65 mol%. The purity level is expected to cause reduced steam production in the ethylbenzene plant. However, without considering the impact in the ethylbenzene plant the savings in operating cost for a 950,000 kta ethylene plant combined with a 550,000 kta ethylbenzene plant

are estimated to be about \$850,000 per annum at current energy price levels.

Example 4

[33] In system such as that illustrated in FIG. 4, the
5 entire effluent 44 from the acetylene converter 43 is
sent to the ethylene fractionator 47 and the dilute
ethylene feed to the ethylbenzene plant 46 is drawn off
via stream 45 as a liquid from the rectification
portion of the ethylene fractionator 47. Energy is
10 saved in the ethylene fractionator 47 but is partly
lost in the form of lower recuperation from ethane
recycle. A higher reflux requirement in the
deethanizer is not needed for this case since the side-
draw is taken above the feed where propylene
15 concentration is already sufficiently low. The purity
of the dilute ethylene stream 45 is about 82 mol% to
about 85 mol%. This case produces the highest purity
of dilute ethylene feed and has no significant impact
in the ethylbenzene plant. The savings in operating
20 cost for a 950,000 kta ethylene plant combined with a
550,000 kta ethylbenzene plant are estimated to be
about \$780,000 per annum at current energy price
levels.

[34] While the above description contains many
25 specifics, these specifics should not be construed as

limitations on the scope of the invention, but merely
as exemplifications of preferred embodiments thereof.
Those skilled in the art will envision many other
possible variations that are within the scope and
5 spirit of the invention as defined by the claims
appended hereto.

WHAT IS CLAIMED IS:

1. In a process for the production of ethylbenzene from a dilute ethylene stream wherein an ethylene-containing stream derived from the cracking of a hydrocarbon feed is directed to an ethylene fractionator for separation of ethylene and ethane, an improvement comprising:

a) providing the dilute ethylene stream by

i. liquefying and separating out a portion of the ethylene-containing stream prior to directing the remainder of the ethylene-containing stream to the ethylene fractionator, and/or by

ii. drawing off a side stream from the ethylene fractionator; and,

b) directing said dilute ethylene stream as a feed to an alkylator for alkylation with benzene to produce ethylbenzene-containing effluent.

2. The process of claim 1 wherein said cracking of a hydrocarbon feed is a thermal cracking process.

3. The process of claim 2 wherein the hydrocarbon feed is selected from the group consisting of ethane, propane, butane, naphtha, gas oil, hydrocracked vacuum gas oil and combinations thereof.

4. The process of claim 2 wherein the hydrocarbon feed is ethane or naphtha.

5. The process of claim 1 wherein the dilute ethylene stream has an ethylene content of from about 60 mol% to about 85 mol%.

6. The process of claim 1 wherein the dilute ethylene stream is provided by first separating out the portion of the ethylene-containing stream and then substantially totally condensing said separated portion to produce a liquefied dilute ethylene stream for use as the alkylator feed.

7. The process of claim 6 wherein the dilute ethylene stream has an ethylene content of from about 80 mol% to about 83 mol%.

8. The process of claim 1 wherein the dilute ethylene stream is provided by cooling the ethylene-containing stream sufficiently to partially condense the ethylene stream to provide a liquefied dilute ethylene stream for use as the alkylator feed and an uncondensed remaining portion of the ethylene-containing stream which is then directed to the ethylene fractionator as a vapor.

9. The process of claim 8 wherein the dilute ethylene stream has an ethylene content of from about 72 mol% to about 78 mol%.

5 10. The process of claim 1 wherein the dilute ethylene stream is provided as a liquid or vapor side draw from a stripping section of the ethylene fractionator.

10 11. The process of claim 10 wherein the dilute ethylene stream has an ethylene content of from about 60 mol% to about 65 mol%.

15 12. The process of claim 1 wherein the dilute ethylene stream is provided as a liquid or vapor side draw from a rectification section of the ethylene fractionator.

20 13. The process of claim 12 wherein the dilute ethylene stream has an ethylene content of from about 82 mol% to about 85 mol%.

14. The process of claim 1 wherein the ethane separated by the ethylene fractionator is recycled to a cracking zone.

25 15. The process of claim 1 further comprising fractionating the ethylbenzene-containing effluent from the

alkylator in a first fractionator to provide an overhead stream containing unconverted benzene and a bottom stream containing ethylbenzene.

5 16. The process of claim 15 comprising recycling at least a portion of the overhead stream from the first fractionator to the alkylator.

10 17. The process of claim 16 further comprising fractionating the bottom stream of the first fractionator in a second fractionator to provide an ethylbenzene overhead and a bottom stream containing polyethylbenzene.

15 18. The process of claim 17 wherein the bottom stream of the second alkylator is fractionated in a third fractionator to provide a polyethylbenzene-containing overhead stream, and recycling the polyethylbenzene-containing overhead stream to a transalkylator for transalkylation with a portion of the unconverted benzene
20 recycled from the first fractionator.

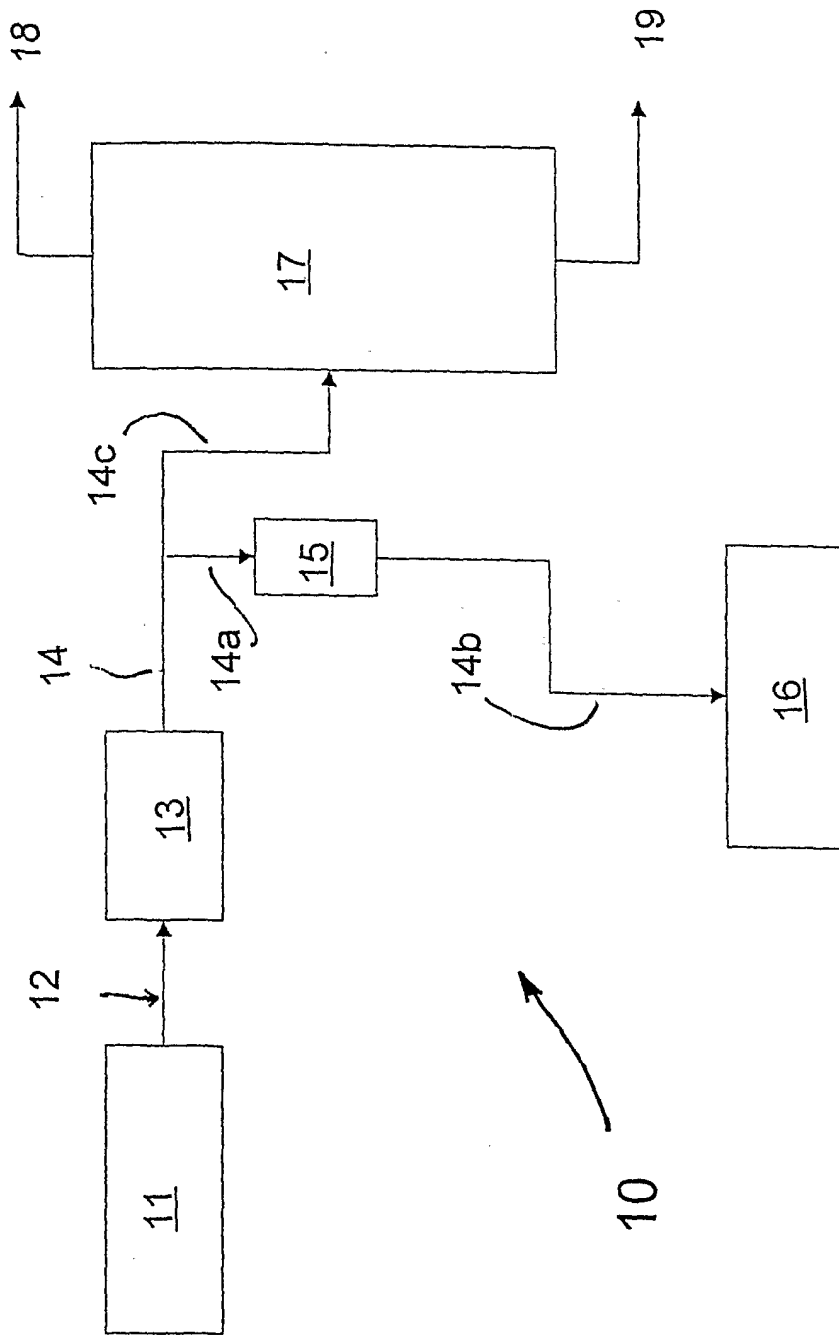

FIG. 1

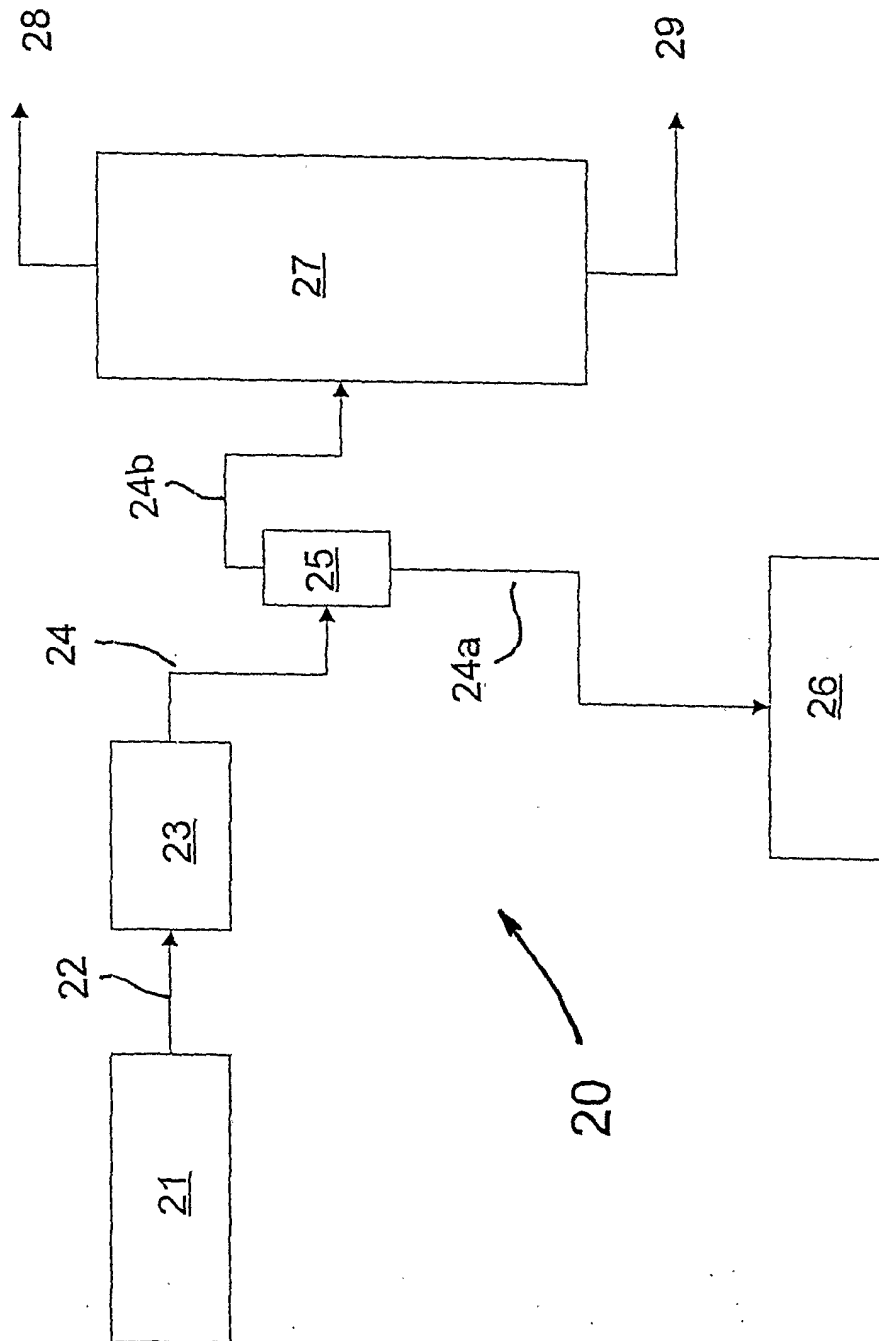

FIG. 2

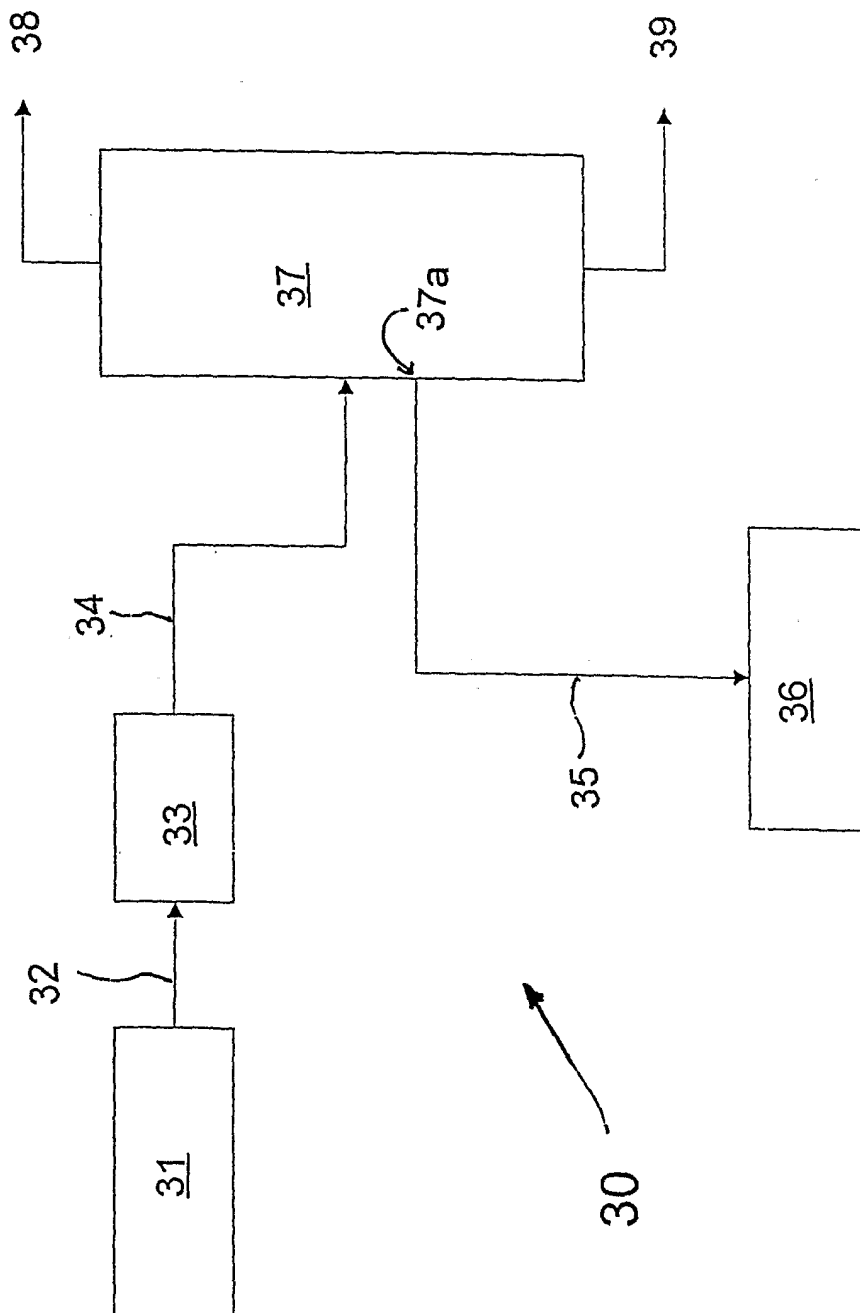

FIG. 3

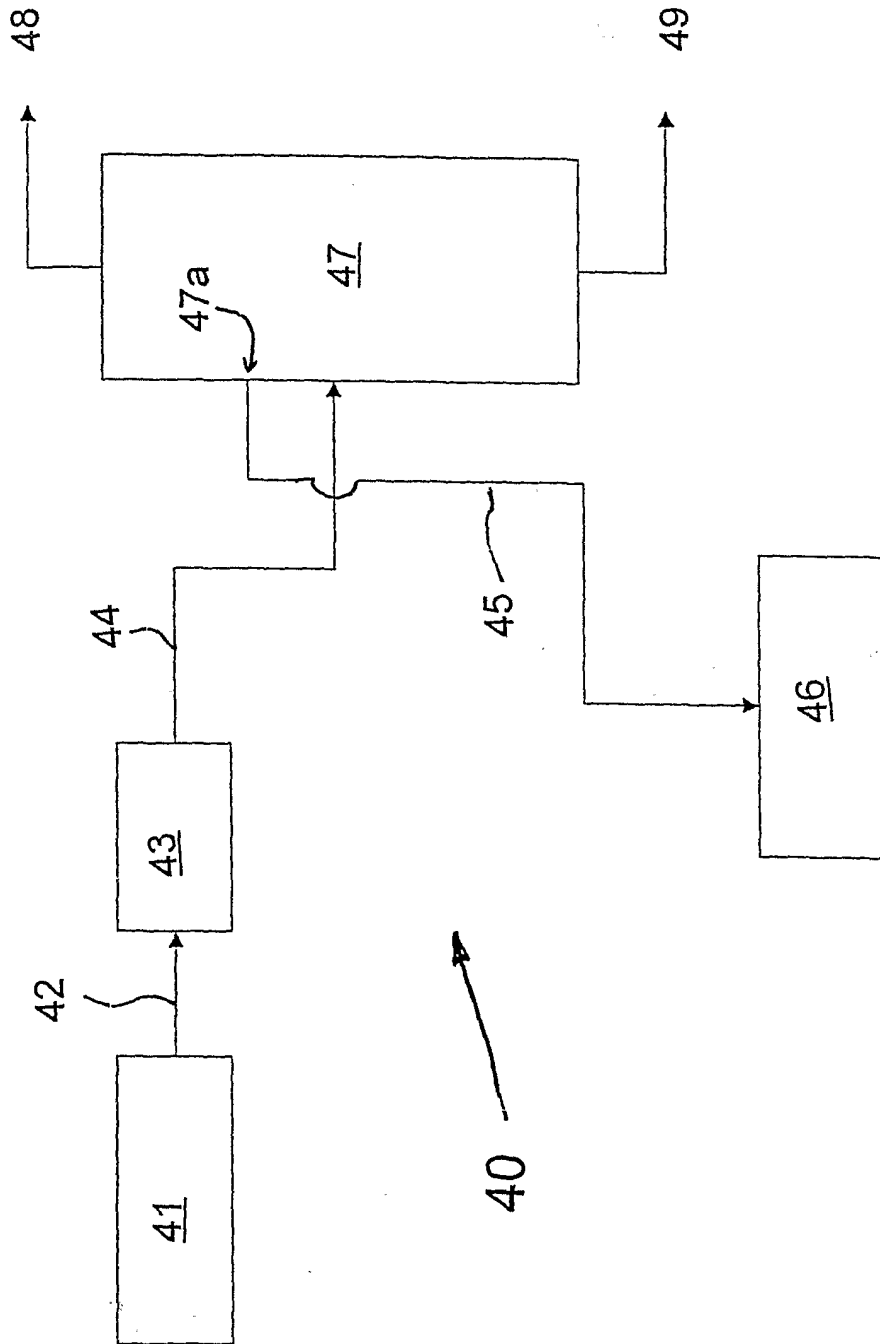

FIG. 4

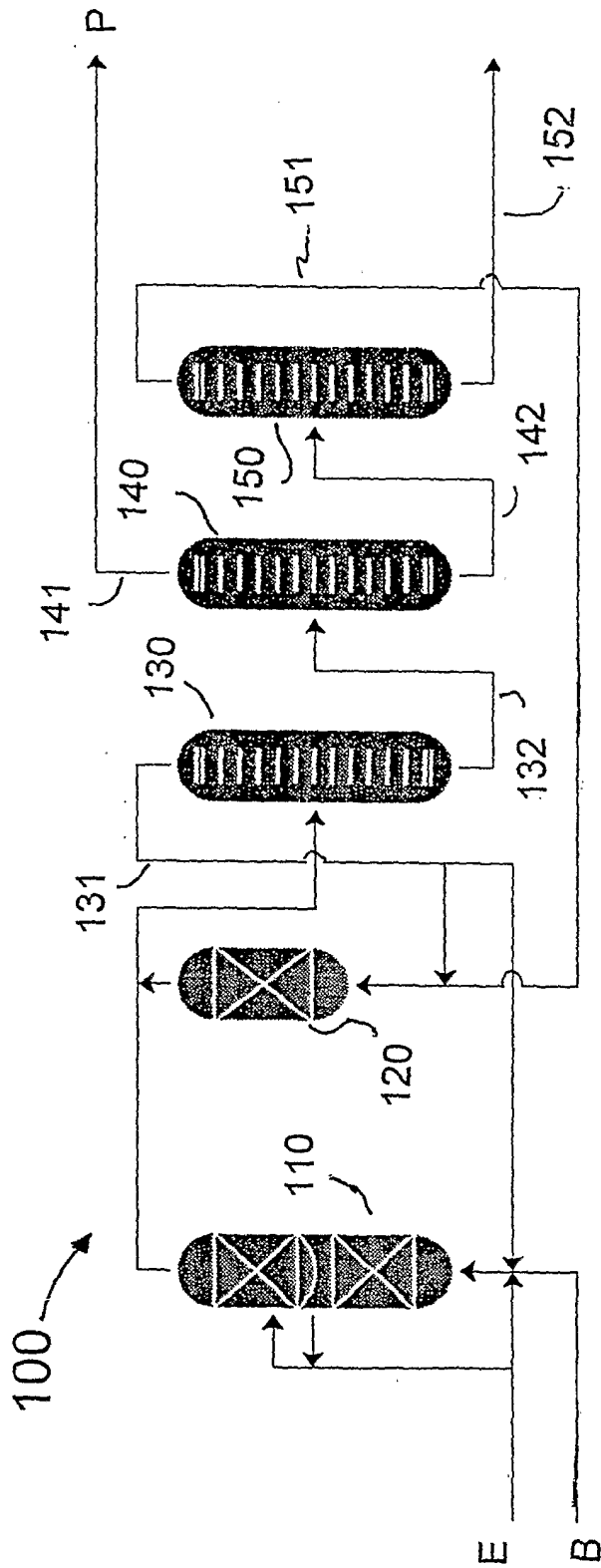

FIG. 5