



INTERNATIONAL APPLICATION PUBLISHED UNDER THE PATENT COOPERATION TREATY (PCT)

<p>(51) International Patent Classification ⁶ : G06F 17/60, 17/30, 15/16, 12/00</p>	<p>A1</p>	<p>(11) International Publication Number: WO 00/33228 (43) International Publication Date: 8 June 2000 (08.06.00)</p>
<p>(21) International Application Number: PCT/US99/28628 (22) International Filing Date: 2 December 1999 (02.12.99) (30) Priority Data: 09/204,888 3 December 1998 (03.12.98) US 09/268,526 12 March 1999 (12.03.99) US 09/268,519 12 March 1999 (12.03.99) US (71) Applicant (for all designated States except US): TELECOM PARTNERS LTD. [US/US]; 900 Town Center, New Britain, PA 18901 (US). (72) Inventor; and (75) Inventor/Applicant (for US only): ELDERING, Charles, A. [US/US]; 315 Hedgerow Lane, Doylestown, PA 18901 (US). (74) Agents: BLASKO, John, P. et al.; J.P. Blasko Professional Corp., 107 North Broad Street, Doylestown, PA 18901 (US).</p>		<p>(81) Designated States: AE, AL, AM, AT, AU, AZ, BA, BB, BG, BR, BY, CA, CH, CN, CR, CU, CZ, DE, DK, DM, EE, ES, FI, GB, GD, GE, GH, GM, HR, HU, ID, IL, IN, IS, JP, KE, KG, KP, KR, KZ, LC, LK, LR, LS, LT, LU, LV, MD, MG, MK, MN, MW, MX, NO, NZ, PL, PT, RO, RU, SD, SE, SG, SI, SK, SL, TJ, TM, TR, TT, TZ, UA, UG, US, UZ, VN, YU, ZA, ZW, ARIPO patent (GH, GM, KE, LS, MW, SD, SL, SZ, TZ, UG, ZW), Eurasian patent (AM, AZ, BY, KG, KZ, MD, RU, TJ, TM), European patent (AT, BE, CH, CY, DE, DK, ES, FI, FR, GB, GR, IE, IT, LU, MC, NL, PT, SE), OAPI patent (BF, BJ, CF, CG, CI, CM, GA, GN, GW, ML, MR, NE, SN, TD, TG). Published <i>With international search report. Before the expiration of the time limit for amending the claims and to be republished in the event of the receipt of amendments.</i></p>

(54) Title: CONSUMER PROFILING AND ADVERTISEMENT SELECTION SYSTEM

(57) Abstract

A consumer profiling and advertisement selection system (500) is presented in which consumers (100) can be characterized based on their purchase or viewing habits. The result of this process is a consumer characterization vector (562) describing the probabilistic demographics and product preferences of the subscriber or viewer (100). Advertisement characterization vectors (548) describing an actual or hypothetical market for a product or desired viewing audience can be determined. The ad characteristics including an ad demographic vector (548), an ad product category (552) and an ad product preference vector (554) is transmitted along with a consumer ID (512).

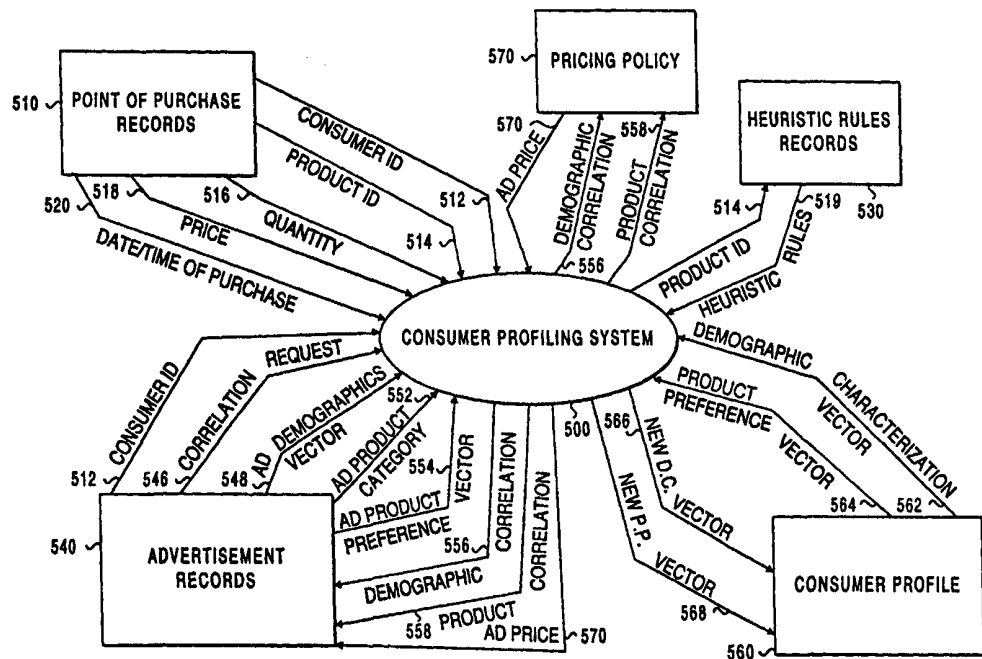

The consumer ID (512) is used to retrieve a consumer characterization vector (562) which is correlated with the ad characterization vector (548) to determine the suitability of the advertisement to the consumer (100). A price for displaying the advertisement can be determined based on the results of the correlation of the ad characteristics with the consumer characterization vector (562). The system can be used to both increase the effectiveness and cost efficiency of advertisements, as well as for determining the price for transmitting or viewing an advertisement, based on the collection of the ad with the consumer profile.

FOR THE PURPOSES OF INFORMATION ONLY

Codes used to identify States party to the PCT on the front pages of pamphlets publishing international applications under the PCT.

AL	Albania	ES	Spain	LS	Lesotho	SI	Slovenia
AM	Armenia	FI	Finland	LT	Lithuania	SK	Slovakia
AT	Austria	FR	France	LU	Luxembourg	SN	Senegal
AU	Australia	GA	Gabon	LV	Latvia	SZ	Swaziland
AZ	Azerbaijan	GB	United Kingdom	MC	Monaco	TD	Chad
BA	Bosnia and Herzegovina	GE	Georgia	MD	Republic of Moldova	TG	Togo
BB	Barbados	GH	Ghana	MG	Madagascar	TJ	Tajikistan
BE	Belgium	GN	Guinea	MK	The former Yugoslav Republic of Macedonia	TM	Turkmenistan
BF	Burkina Faso	GR	Greece	ML	Mali	TR	Turkey
BG	Bulgaria	HU	Hungary	MN	Mongolia	TT	Trinidad and Tobago
BJ	Benin	IE	Ireland	MR	Mauritania	UA	Ukraine
BR	Brazil	IL	Israel	MW	Malawi	UG	Uganda
BY	Belarus	IS	Iceland	MX	Mexico	US	United States of America
CA	Canada	IT	Italy	NE	Niger	UZ	Uzbekistan
CF	Central African Republic	JP	Japan	NL	Netherlands	VN	Viet Nam
CG	Congo	KE	Kenya	NO	Norway	YU	Yugoslavia
CH	Switzerland	KG	Kyrgyzstan	NZ	New Zealand	ZW	Zimbabwe
CI	Côte d'Ivoire	KP	Democratic People's Republic of Korea	PL	Poland		
CM	Cameroon	KR	Republic of Korea	PT	Portugal		
CN	China	KZ	Kazakstan	RO	Romania		
CU	Cuba	LC	Saint Lucia	RU	Russian Federation		
CZ	Czech Republic	LI	Liechtenstein	SD	Sudan		
DE	Germany	LK	Sri Lanka	SE	Sweden		
DK	Denmark	LR	Liberia	SG	Singapore		
EE	Estonia						

TITLE

Consumer profiling and advertisement selection system

Background of the Invention

5 The advent of the Internet has resulted in the ability to communicate data across the globe instantaneously, and will allow for numerous new applications which enhance consumer's lives. One of the enhancements which can occur is the ability for the consumer to receive advertising which is relevant to their lifestyle, rather than a stream of ads determined by the program they are watching. Such "targeted ads" can potentially reduce the amount of unwanted information which consumers receive in the mail, during television programs, and when using the Internet. Examples of editorial targeting can be found on the World Wide Web, where banners are delivered based on the page content. The product literature from DoubleClick, "Dynamic Advertising Reporting and Targeting (DART)," printed from the World Wide Web site <http://www.doubleclick.net/dart> on June 19, 1998 discloses DoubleClick's advertising solution for matching advertiser's selected targeted profiles with individual user profiles and deliver an appropriate banner. The user and advertisements are matched based on geographic location or keywords on the page content. The product literature from 25 Imgis, "Ad Force," printed from the World Wide Web site <http://www.starpt.com/core> on June 30, 1998 discloses an ad management system for targeting users and delivering advertisements to them. Users are targeted based on the type of content they are viewing or by keywords.

30 From an advertiser's perspective the ability to target ads can be beneficial since they have some confidence that their ad will at least be determined relevant by the consumer, and therefore will not be found annoying because it is not applicable to their lifestyle. Different systems

for matching a consumer profile to an advertisement have been proposed such as the U.S. Patent No. 5,774,170, which discloses a system for delivering targeted advertisement to consumers. In this system, a set of advertisements is tagged
5 with commercial identifier (CID) and, from the existing marketing database, a list of prospective viewers is also identified with CID. The commercials are displayed to the consumers when the CIDs match.

Other systems propose methods for delivering
10 programming tailored to subscribers' profile. U.S. Patent No. 5,446,919 discloses a communication system capable of targeting a demographically or psychographically defined audience. Demographic and psychographic information about audience member are downloaded and stored in the audience
15 member receiver. Media messages are transmitted to audience member along with a selection profile command, which details the demographic/psychographic profile of audience members that are to receive each media message. Audience members which fall within a group identified by the selection
20 profile command are presented with the media message.

U.S. Patent No. 5,223,924 discloses a system and method for automatically correlating user preferences with a TV program information database. The system includes a processor that performs "free text" search techniques to
25 correlate the downloaded TV program information with the viewer's preferences. U.S. Patent No. 5,410,344 discloses a method for selecting audiovideo programs based on viewers' preferences, wherein each of the audiovideo programs has a plurality of programs attributes and a corresponding content
30 code representing the program attributes. The method comprises the steps of storing a viewer preference file, which includes attributes ratings, which represents the degree of impact of the programs attributes on the viewer and, in response to the comparison of viewer preference file

with the program content codes, a program is selected for presentation to the viewer.

In order to determine the applicability of an advertisement to a consumer, it is necessary to know something about their lifestyle, and in particular to understand their demographics (age, household size and income). In some instances, it is useful to know their particular purchasing habits. Purchasing habits are being used by E-commerce to profile their visitors. As an example, the product literature from Aptex software Inc., "SelectCast for Commerce Servers," printed from the World Wide Web site <http://www.aptex.com/products-selectcast-commerce.htm> on June 30, 1998 discloses the product SelectCast for Commerce Servers. The product personalizes online shopping based on observed user behavior. User interests are learned based on the content they browse, the promotions they click and the products they purchase.

Knowledge of the purchasing habits of a consumer can be beneficial to a product vendor in the sense that a vendor of soups would like to know which consumers are buying their competitor's soup, so that they can target ads at those consumers in an effort to convince them to switch brands. That vendor will probably not want to target loyal customers, although for a new product introduction the strategy may be to convince loyal customers to try the new product. In both cases it is extremely useful for the vendor to be able to determine what brand of product the consumer presently purchases.

There are several difficulties associated with the collection, processing, and storage of consumer data. First, collecting consumer data and determining the demographic parameters of the consumer can be difficult. Surveys can be performed, and in some instances the consumer will willingly give access to normally private data

including family size, age of family members, and household income. In such circumstances there generally needs to be an agreement with the consumer regarding how the data will be used. If the consumer does not provide this data
5 directly, the information must be "mined" from various pieces of information which are gathered about the consumer, typically from specific purchases.

A relatively intrusive method for collecting consumer information is described in U.S. Patent No. 4,546,382, which
10 discloses a television and market research data collection system and method. A data collection unit containing a memory, stores data as to which of the plurality of TV modes are in use, which TV channel is being viewed as well as input from a suitable optical scanning device for collecting
15 consumer product purchases.

Once data is collected, usually from one source, some type of processing can be performed to determine a particular aspect of the consumer's life. As an example, processing can be performed on credit data to determine
20 which consumers are a good credit risk and have recently applied for credit. The resulting list of consumers can be solicited, typically by direct mail. Although information such as credit history is stored on multiple databases, storage of other information such as the specifics of
25 grocery purchases is not typically performed. Even if each individual's detailed list of grocery purchases was recorded, the information would be of little use since it would amount to nothing more than unprocessed shopping lists.

30 Privacy concerns are also an important factor in using consumer purchase information. Consumers will generally find it desirable that advertisements and other information is matched with their interests, but will not allow

indiscriminate access to their demographic profile and purchase records.

The Internet has spawned the concept of "negatively priced information" in which consumers can be paid to receive advertising. Paying consumers to watch advertisements can be accomplished interactively over the Internet, with the consumer acknowledging that they will watch an advertisement for a particular price. Previously proposed schemes such as that described in U.S. Patent 5,794,210, entitled "Attention Brokerage," of which A. Nathaniel Goldhaber and Gary Fitts are the inventors, describe such a system, in which the consumer is presented with a list of advertisements and their corresponding payments. The consumer chooses from the list and is compensated for viewing the advertisement. The system uses also software agents representing consumers to match the consumer interest profiles with advertisements. The matching is done using "relevance indexing" which is based on hierarchical tree structures. The system requires real-time interactivity in that the viewer must select the advertisement from the list of choices presented.

The ability to place ads to consumers and compensate them for viewing the advertisements opens many possibilities for new models of advertising. However, it is important to understand the demographics and product preferences of the consumer in order to be able to determine if an advertisement is appropriate.

Although it is possible to collect statistical information regarding consumers of particular products and compare those profiles against individual demographic data points of consumers, such a methodology only allows for selection of potential consumers based on the demographics of existing customers of the same or similar products.

U.S. Patent 5,515,098, entitled "System and method for selectively distributing commercial messages over a communications network," of which John B. Carles is the inventor, describes a method in which target household data
5 of actual customers of a product are compared against subscriber household data to determine the applicability of a commercial to a household. Target households for a product or service are characterized by comparing or correlating the profile of the customer household to the profile of all
10 households. A rating is established for each household for each category of goods/services. The households within a predefined percentile of subscribers, as defined by the rating, are targeted by the advertiser of the product or service.

15 It will also frequently be desirable to target an advertisement to a market having discretionary characteristics and to obtain a measure of the correlation of these discretionary features with probabilistic or deterministic data of the consumer/subscriber, rather than
20 being forced to rely on the characteristics of existing consumers of a product. Such correlation should be possible based both on demographic characteristics and product preferences.

Another previously proposed system, described in U.S.
25 Patent 5,724,521, entitled "Method and apparatus for providing electronic advertisements to end users in a consumer best-fit pricing manner," of which R. Dedrick is the inventor, utilizes a consumer scale as the mechanism to determine to which group an advertisement is intended. A
30 consumer scale matching process compares the set of characteristics stored in a user profile database to a consumer scale associated with the electronic advertisement. The fee charged to the advertiser is determined by where the set of characteristics fall on the consumer scale. Such a

system requires specification of numerous parameters and weighting factors, and requires access to specific and non-statistical personal profile information.

For the foregoing reasons, there is a need for a
5 consumer profiling system which can profile the consumer,
provide access to the consumer profile in a secure manner,
and return a measurement of the potential applicability of
an advertisement. There is also a need for an advertisement
selection system which can match an advertisement with
10 discretionary target market characteristics, and which can
do so in a manner which protects the privacy of the consumer
data and characterizations.

Summary of the Invention

15 The present invention supports the receipt of consumer
purchase information with which consumer characterization
vectors are updated based on product characterization
information. The consumer characterization vectors include
a consumer demographic vector which provides a probabilistic
20 measure of the demographics of the consumer, and a product
preference vector which describes which products the
consumer has typically purchased in the past, and therefore
is likely to purchase in the future. The product
characterization information includes vector information
25 which represents probabilistic determinations of the
demographics of purchasers of an item, heuristic rules which
can be applied to probabilistically describe the
demographics of the consumer based on that purchase, and a
vector representation of the purchase itself.

30 In a preferred embodiment a computer-readable detailed
purchase record is received, along with a unique consumer
identifier. A demographic characterization vector
corresponding to the consumer can be retrieved. In the
event that there is no existing demographic characterization

vector for that consumer, a new demographic characterization vector can be created. In a preferred embodiment the new demographic characterization vector contains no information. A set of heuristic rules is retrieved and contains a
5 probabilistic measure of the demographic characteristics of a typical purchaser of an item. A new demographic characterization vector is calculated based on the purchase, the existing demographic characterization vector, and the heuristic rules.

10 In a preferred embodiment the calculation of the demographic characterization vector is performed by calculating a weighted average of a product demographics vector and the existing demographic characterization vector. A weighting factor is used in which the weighting factor is
15 determined based on the ratio of the current product purchase amount to a cumulative product purchase amount. The cumulative product purchase amount can be measured as the amount spent on a particular category of items (e.g. groceries, clothes, accessories) over a given period of time
20 such as one month or one year.

In a preferred embodiment the heuristic rules are in the form of a product demographics vector which states the demographics of known purchasers of an item. Each product can have an associated product demographics vector.

25 The present invention can be used to develop product preference descriptions of consumers which describe the brand and size product that they purchase, and which provide a probabilistic interpretation of the products they are likely to buy in the future. The product preference
30 description can be generated by creating a weighted average of an existing product preference vector describing the consumer's historical product preferences (type of product, brand, and size) and the characteristics of recent purchases.

The present invention can be realized as a data processing system or computer program which processes consumer purchase records and updates their demographic and product preference profiles based on the use of product
5 characterization information. The data processing system can also be used to receive information regarding an advertisement and to perform a correlation between the advertisement and the consumer's demographic and product preferences.

10 The present invention can be realized as software resident on one or more computers. The system can be realized on an individual computer which receives information regarding consumer purchases, or can be realized on a network of computers in which portions of the system
15 are resident on different computers.

One advantage of the present invention is that it allows consumer profiles to be updated automatically based on their purchases, and forms a description of the consumer including demographic characteristics and product
20 preferences. This description can be used by advertisers to determine the suitability of advertisements to the consumer. Consumers benefit from the system since they will receive advertisements which are more likely to be applicable to them.

25 The present invention can be used to profile consumers to support the correlation of an advertisement characterization vector associated with an advertisement with the consumer characterization vector to determine the applicability of the advertisement to the consumer.

30 Another feature of the present invention is the ability to price access to the consumer based on the degree of correlation of an advertisement with their profile. If an advertisement is found to be very highly correlated with a consumer's demographics and product preferences, a

relatively high price can be charged for transmitting the advertisement to the consumer. From the consumer's perspective, if the correlation between the advertisement and the consumer's demographics or product preferences is high the consumer can charge less to view the ad, since it is likely that it will be of interest.

The present invention also describes a system for determining the applicability of an advertisement to a consumer, based on the reception of an ad characterization vector and use of a unique consumer ID. The consumer ID is used to retrieve a consumer characterization vector, and the correlation between the consumer characterization vector and the ad characterization vector is used to determine the applicability of the advertisement to the consumer. The price to be paid for presentation of the advertisement can be determined based on the degree of correlation.

The price to present an advertisement can increase with correlation, as may be typical when the content/opportunity provider is also the profiling entity. The price can decrease with correlation when the consumer is the profiler, and is interested in, and willing to charge less for seeing advertisements which are highly correlated with their demographics, lifestyle, and product preferences.

The present invention can be used to specify purchasers of a specific product. In a preferred embodiment the advertisement characterization vector contains a description of a target market including an indicator of a target product, i.e., purchasers of a particular product type, brand, or product size. The advertisement characterization vector is correlated with a consumer characterization vector which is retrieved based on a unique consumer ID. The correlation factor is determined and indicates if the consumer is a purchaser of the product the advertisement is intended for. This feature can be used to identify

purchasers of a particular brand and can be used to target ads at those consumers to lure them away from their present product provider. Similarly, this feature can be used to target ads to loyal consumers to introduce them to a new
5 product in a product family, or different size of product.

One advantage of the present invention is that discretionary target market parameters can be specified and do not necessarily need to correspond to an existing market, but can reflect the various market segments for which the
10 advertisement is targeted. The market segments can be designated by demographic characteristics or by product preferences.

Another advantage of the present invention is that demographic samples of present purchasers of a product are
15 not required to define the target market.

The present invention can be used to determine the applicability of an advertisement to a consumer based on demographics, product preferences, or a combination of both.

In a preferred embodiment of the present invention the
20 correlation is calculated as the scalar product of the ad characterization vector and the consumer characterization vector. The ad characterization vector and consumer characterization vector can be composed of demographic characteristics, product purchase characteristics, or a
25 combination of both.

In a preferred embodiment pricing for the displaying of said advertisement is developed based on the result of the correlation between the ad characterization vector and the consumer characterization vector. In a first embodiment the
30 pricing increases as a function of the correlation. This embodiment can represent the situation in which the party which determines the correlation also controls the ability to display the advertisement.

In an alternate embodiment the price for displaying the advertisement decreases as a function of the degree of correlation. This embodiment can represent the situation in which the consumer controls access to the consumer
5 characterization vector, and charges less to view advertisements which are highly correlated with their interests and demographics. A feature of this embodiment is the ability of the consumer to decrease the number of unwanted advertisements by charging a higher price to view
10 advertisements which are likely to be of less interest.

One advantage of the present invention is that it allows advertisements to be directed to new markets by setting specific parameters in the ad characterization vector, and does not require specific statistical knowledge
15 regarding existing customers of similar products. Another advantage is that the system allows ads to be directed at consumers of a competing brand, or specific targeting at loyal customers. This feature can be useful for the introduction of a new product to an existing customer base.

Another advantage of the present invention is that the
20 correlation can be performed by calculating a simple scalar (dot) product of the ad characterization and consumer characterization vectors. A weighted sum or other statistical analysis is not required to determine the
25 applicability of the advertisement.

The present invention can be realized as a data processing system and as a computer program. The invention can be realized on an individual computer or can be realized using distributed computers with portions of the system
30 operating on various computers.

An advantage of the present invention is the ability to direct advertisements to consumers which will find the advertisements of interest. This eliminates unwanted advertisements. Another advantage is the ability of

advertisers to target specific groups of potential customers.

These and other features and objects of the invention will be more fully understood from the following detailed description of the preferred embodiments which should be read in light of the accompanying drawings.

Brief Description of the Drawings

The accompanying drawings, which are incorporated in and form a part of the specification, illustrate the embodiments of the present invention and, together with the description serve to explain the principles of the invention.

In the drawings:

FIGS. 1A and 1B show user relationship diagrams for the present invention;

FIGS. 2A, 2B, 2C and 2D illustrate a probabilistic consumer demographic characterization vector, a deterministic consumer demographic characterization vector, a consumer product preference characterization vector, and a storage structure for consumer characterization vectors respectively;

FIGS. 3A and 3B illustrate an advertisement demographic characterization vector and an advertisement product preference characterization vector respectively;

FIG. 4 illustrates a computer system on which the present invention can be realized;

FIG. 5 illustrates a context diagram for the present invention;

FIGS. 6A and 6B illustrate pseudocode updating the characteristics vectors and for a correlation operation respectively;

FIG. 7 illustrates heuristic rules;

FIGS 8A and 8B illustrate flowcharts for updating consumer characterization vectors and a correlation operation respectively; and

FIG. 9 represents pricing as a function of correlation.

5 FIG. 10 illustrates a representation of a consumer characterization as a set of basis vectors and an ad characterization vector.

Detailed Description of the Preferred Embodiment

10

In describing a preferred embodiment of the invention illustrated in the drawings, specific terminology will be used for the sake of clarity. However, the invention is not intended to be limited to the specific terms so selected, and it is to be understood that each specific term includes all technical equivalents which operate in a similar manner to accomplish a similar purpose.

15

With reference to the drawings, in general, and FIGS. 1 through 10 in particular, the method and apparatus of the present invention is disclosed.

20

FIG. 1A shows a user relationship diagram which illustrates the relationships between a consumer profiling system and various entities. As can be seen in FIG. 1, a consumer 100 can receive information and advertisements from a consumer personal computer (PC) 104, displayed on a television 108 which is connected to a settop 106, or can receive a mailed ad 182.

25

Advertisements and information displayed on consumer PC 104 or television 108 can be received over an Internet 150, or can be received over the combination of the Internet 150 with another telecommunications access system. The telecommunications access system can include but is not limited to cable TV delivery systems, switched digital video access systems operating over telephone wires, microwave

30

telecommunications systems, or any other medium which provides connectivity between the consumer 100 and a content server 162 and ad server 146.

A content/opportunity provider 160 maintains the
5 content server 162 which can transmit content including broadcast programming across a network such as the Internet 150. Other methods of data transport can be used including private data networks and can connect the content sever 160 through an access system to a device owned by consumer 100.

10 Content/opportunity provider 160 is termed such since if consumer 100 is receiving a transmission from content server 162, the content/opportunity provider can insert an advertisement. For video programming, content/opportunity provider is typically the cable network operator or the
15 source of entertainment material, and the opportunity is the ability to transmit an advertisement during a commercial break.

The majority of content that is being transmitted today is done so in broadcast form, such as broadcast television
20 programming (broadcast over the air and via cable TV networks), broadcast radio, and newspapers. Although the interconnectivity provided by the Internet will allow consumer specific programming to be transmitted, there will still be a large amount of broadcast material which can be
25 sponsored in part by advertising. The ability to insert an advertisement in a broadcast stream (video, audio, or mailed) is an opportunity for advertiser 144. Content can also be broadcast over the Internet and combined with existing video services, in which case opportunities for the
30 insertion of advertisements will be present.

Although FIG. 1A represents content/opportunity provider 160 and content server 162 as being independently connected to Internet 150, with the consumer's devices being also being directly connected to the Internet 150, the

content/opportunity provider 160 can also control access to the subscriber. This can occur when the content/opportunity provider is also the cable operator or telephone company. In such instances, the cable operator or telephone company can
5 be providing content to consumer 100 over the cable operator/telephone company access network. As an example, if the cable operator has control over the content being transmitted to the consumer 100, and has programmed times for the insertion of advertisements, the cable operator is
10 considered to be a content/opportunity provider 160 since the cable operator can provide advertisers the opportunity to access consumer 100 by inserting an advertisement at the commercial break.

In a preferred embodiment of the present invention, a
15 pricing policy can be defined. The content/opportunity provider 160 can charge advertiser 144 for access to consumer 100 during an opportunity. In a preferred embodiment the price charged for access to consumer 100 by content/opportunity provider varies as a function of the
20 applicability of the advertisement to consumer 100. In an alternate embodiment consumer 100 retains control of access to the profile and charges for viewing an advertisement.

The content provider can also be a mailing company or printer which is preparing printed information for consumer
25 100. As an example, content server 162 can be connected to a printer 164 which creates a mailed ad 182 for consumer 100. Alternatively, printer 164 can produce advertisements for insertion into newspapers which are delivered to consumer 100. Other printed material can be generated by printer 162
30 and delivered to consumer 100 in a variety of ways.

Advertiser 144 maintains an ad server 146 which contains a variety of advertisements in the form of still video which can be printed, video advertisements, audio advertisements, or combinations thereof.

Profiler 140 maintains a consumer profile server 130 which contains the characterization of consumer 100. The consumer profiling system is operated by profiler 140, who can use consumer profile server 130 or another computing
5 device connected to consumer profile server 130 to profile consumer 100.

Data to perform the consumer profiling is received from a point of purchase 110. Point of purchase 110 can be a grocery store, department store, other retail outlet, or can
10 be a web site or other location where a purchase request is received and processed. In a preferred embodiment, data from the point of purchase is transferred over a public or private network 120, such as a local area network within a store or a wide area network which connects a number of
15 department or grocery stores. In an alternate embodiment the data from point of purchase 110 is transmitted over the Internet 150 to profiler 140.

Profiler 140 may be a retailer who collects data from its stores, but can also be a third party who contracts with
20 consumer 100 and the retailer to receive point of purchase data and profile consumer 100. Consumer 100 may agree to such an arrangement based on the increased convenience offered by targeted ads, or through a compensation arrangement in which they are paid on a periodic basis for
25 revealing their specific purchase records.

Consumer profile server 130 can contain a consumer profile which is determined from observation of the consumer's viewing habits on television 108 or consumer PC
104. Determination of demographic and product preference
30 information based on the consumer's use of services such as cable television and Internet access can be performed by monitoring the channel selections that a subscriber makes, and determining household demographics based on the

subscriber selections and information associated with the programming being watched.

In one embodiment the channel selections are recorded, and based on the time of day during which the programming is watched and duration of viewing, heuristic rules are applied to make probabilistic determinations regarding the household demographics including age, gender, household size and income, as illustrated in FIG. 2A. This can be accomplished by applying heuristic rules which associate the programming with known and assumed characteristics for viewers of the programming. As an example, it is known that the probability that the viewer of a cartoon in the morning is in the 3-8 year old age group is high, thus if the household viewing habits consistently record viewing of cartoons the probability that the household will contain one or more viewers in the 3-8 year old age group is high.

In one embodiment information regarding the program is extracted from the Electronic Program Guide (EPG) which contains information regarding the scheduled programming. In another embodiment information regarding the programming is retrieved from the closed caption channel transmitted in the broadcast signal.

The volume at which the program is watched can also be stored and forms an additional basis for subscriber characterization, wherein the muting of a channel indicates limited interest in a particular program or advertisement. In the case of an advertisement, muting of the advertisement can be used as a measure of the effectiveness (or ineffectiveness) of the advertisement and can serve as part of the basis for the subscriber characterization. The muting of a program, as well as the duration for which the program is watched, can also be used in the determination of the subscriber characterization vector.

By processing the recorded viewing habits in conjunction with programming related information and heuristic rules similar to those illustrated in FIG. 7 but related to programming rather than purchases, it is possible
5 to construct a subscriber characterization vector which contains a probabilistic demographic profile of the household.

When used herein, the term consumer characterization vector also represents the subscriber characterization
10 vector previously described. Both the consumer characterization vector and the subscriber characterization vector contain demographic and product preference information which is related to consumer 100.

FIG. 1B illustrates an alternate embodiment of the
15 present invention in which the consumer 100 is also profiler 140. Consumer 100 maintains consumer profile server 130 which is connected to a network, either directly or through consumer PC 104 or settop 106. Consumer profile server 130 can contain the consumer profiling system, or the profiling
20 can be performed in conjunction with consumer PC 104 or settop 106. A subscriber characterization system which monitors the viewing habits of consumer 100 can be used in conjunction with the consumer profiling system to create a more accurate consumer profile.

25 When the consumer 100 is also the profiler 140, as shown in FIG. 1B, access to the consumer demographic and product preference characterization is controlled exclusively by consumer 100, who will grant access to the profile in return for receiving an increased accuracy of
30 ads, for cash compensation, or in return for discounts or coupons on goods and services.

FIG. 2A illustrates an example of a probabilistic demographic characterization vector. The demographic characterization vector is a representation of the

probability that a consumer falls within a certain demographic category such as an age group, gender, household size, or income range.

In a preferred embodiment the demographic characterization vector includes interest categories. The interest categories may be organized according to broad areas such as music, travel, and restaurants. Examples of music interest categories include country music, rock, classical, and folk. Examples of travel categories include "travels to another state more than twice a year," and travels by plane more than twice a year."

FIG. 2B illustrates a deterministic demographic characterization vector. The deterministic demographic characterization vector is a representation of the consumer profile as determined from deterministic rather than probabilistic data. As an example, if consumer 100 agrees to answer specific questions regarding age, gender, household size, income, and interests the data contained in the consumer characterization vector will be deterministic.

As with probabilistic demographic characterization vectors, the deterministic demographic characterization vector can include interest categories. In a preferred embodiment, consumer 100 answers specific questions in a survey generated by profiler 140 and administered over the phone, in written form, or via the Internet and consumer PC 104. The survey questions correspond either directly to the elements in the probabilistic demographic characterization vector, or can be processed to obtain the deterministic results for storage in the demographic characterization vector.

FIG. 2C illustrates a product preference vector. The product preference represents the average of the consumer preferences over past purchases. As an example, a consumer who buys the breakfast cereal manufactured by Post under the

trademark ALPHABITS about twice as often as purchasing the breakfast cereal manufactured by Kellogg under the trademark CORN FLAKES, but who never purchases breakfast cereal manufactured by General Mills under the trademark WHEATIES, 5 would have a product preference characterization such as that illustrated in FIG. 2C. As shown in FIG. 2C, the preferred size of the consumer purchase of a particular product type can also be represented in the product preference vector.

10 FIG. 2D represents a data structure for storing the consumer profile, which can be comprised of a consumer ID field 237, a deterministic demographic data field 239, a probabilistic demographic data field 241, and one or more product preference data fields 243. As shown in FIG. 2D, 15 the product preference data field 243 can be comprised of multiple fields arranged by product categories 253.

Depending on the data structure used to store the information contained in the vector, any of the previously mentioned vectors may be in the form of a table, record, 20 linked tables in a relational database, series of records, or a software object.

The consumer ID 512 can be any identification value uniquely associated with consumer 100. In a preferred embodiment consumer ID 512 is a telephone number, while in 25 an alternate embodiment consumer ID 512 is a credit card number. Other unique identifiers include consumer name with middle initial or a unique alphanumeric sequence, the consumer address, social security number.

The vectors described and represented in FIGS. 2A-C 30 form consumer characterization vectors that can be of varying length and dimension, and portions of the characterization vector can be used individually. Vectors can also be concatenated or summed to produce longer vectors which provide a more detailed profile of consumer 100. A

matrix representation of the vectors can be used, in which specific elements, such as product categories 253, are indexed. Hierarchical structures can be employed to organize the vectors and to allow hierarchical search algorithms to be used to locate specific portions of vectors.

FIGS. 3A and 3B represent an ad demographics vector and an ad product preference vector respectively. The ad demographics vector, similar in structure to the demographic characterization vector, is used to target the ad by setting the demographic parameters in the ad demographics vector to correspond to the targeted demographic group. As an example, if an advertisement is developed for a market which is the 18-24 and 24-32 age brackets, no gender bias, with a typical household size of 2-5, and income typically in the range of \$20,000-\$50,000, the ad demographics vector would resemble the one shown in FIG. 3A. The ad demographics vector represents a statistical estimate of who the ad is intended for, based on the advertiser's belief that the ad will be beneficial to the manufacturer when viewed by individuals in those groups. The benefit will typically be in the form of increased sales of a product or increased brand recognition. As an example, an "image ad" which simply shows an artistic composition but which does not directly sell a product may be very effective for young people, but may be annoying to older individuals. The ad demographics vector can be used to establish the criteria which will direct the ad to the demographic group of 18-24 year olds.

FIG. 3B illustrates an ad product preference vector. The ad product preference vector is used to select consumers which have a particular product preference. In the example illustrated in FIG. 3B, the ad product preference vector is set so that the ad can be directed to purchasers of ALPHABITS

and WHEATIES, but not at purchasers of CORN FLAKES. This particular setting would be useful when the advertiser represents Kellogg and is charged with increasing sales of CORN FLAKES. By targeting present purchasers of ALPHABITS
5 and WHEATIES, the advertiser can attempt to sway those purchasers over to the Kellogg brand and in particular convince them to purchase CORN FLAKES. Given that there will be a payment required to present the advertisement, in the form of a payment to the content/opportunity provider
10 160 or to the consumer 100, the advertiser 144 desires to target the ad and thereby increase its cost effectiveness.

In the event that advertiser 144 wants to reach only the purchasers of Kellogg's CORN FLAKES, that category would be set at a high value, and in the example shown would be
15 set to 1. As shown in FIG. 3B, product size can also be specified. If there is no preference to size category the values can all be set to be equal. In a preferred embodiment the values of each characteristic including brand and size are individually normalized.

20 Because advertisements can be targeted based on a set of demographic and product preference considerations which may not be representative of any particular group of present consumers of the product, the ad characterization vector can be set to identify a number of demographic groups which
25 would normally be considered to be uncorrelated. Because the ad characterization vector can have target profiles which are not representative of actual consumers of the product, the ad characterization vector can be considered to have discretionary elements. When used herein the term
30 discretionary refers to a selection of target market characteristics which need not be representative of an actual existing market or single purchasing segment.

In a preferred embodiment the consumer characterization vectors shown in FIGS. 2A-C and the ad characterization

vectors represented in FIGS. 3A and 3B have a standardized format, in which each demographic characteristic and product preference is identified by an indexed position. In a preferred embodiment the vectors are singly indexed and thus
5 represent coordinates in n-dimensional space, with each dimension representing a demographic or product preference characteristic. In this embodiment a single value represents one probabilistic or deterministic value (e.g. the probability that the consumer is in the 18-24 year old
10 age group, or the weighting of an advertisement to the age group).

In an alternate embodiment a group of demographic or product characteristics forms an individual vector. As an example, age categories can be considered a vector, with
15 each component of the vector representing the probability that the consumer is in that age group. In this embodiment each vector can be considered to be a basis vector for the description of the consumer or the target ad. The consumer or ad characterization is comprised of a finite set of
20 vectors in a the vector space that describes the consumer or advertisement.

FIG. 4 shows the block diagram of a computer system for a realization of the consumer profiling system. A system bus 422 transports data amongst the CPU 203, the RAM 204, Read
25 Only Memory - Basic Input Output System (ROM-BIOS) 406 and other components. The CPU 203 accesses a hard drive 400 through a disk controller 402. The standard input/output devices are connected to the system bus 422 through the I/O controller 201. A keyboard is attached to the I/O controller
30 201 through a keyboard port 416 and the monitor is connected through a monitor port 418. The serial port device uses a serial port 420 to communicate with the I/O controller 201. Industry Standard Architecture (ISA) expansion slots 408 and Peripheral Component Interconnect (PCI) expansion slots 410

allow additional cards to be placed into the computer. In a preferred embodiment, a network card is available to interface a local area, wide area, or other network. The computer system shown in FIG. 4 can be part of consumer profile server 130, or can be a processor present in another element of the network.

FIG. 5 shows a context diagram for the present invention. Context diagrams are useful in illustrating the relationship between a system and external entities. Context diagrams can be especially useful in developing object oriented implementations of a system, although use of a context diagram does not limit implementation of the present invention to any particular programming language. The present invention can be realized in a variety of programming languages including but not limited to C, C++, Smalltalk, Java, Perl, and can be developed as part of a relational database. Other languages and data structures can be utilized to realize the present invention and are known to those skilled in the art.

Referring to FIG. 5, in a preferred embodiment consumer profiling system 500 is resident on consumer profile server 130. Point of purchase records 510 are transmitted from point of purchase 110 and stored on consumer profile server 130. Heuristic rules 530, pricing policy 570, and consumer profile 560 are similarly stored on consumer profile server 130. In a preferred embodiment advertisement records 540 are stored on ad server 146 and connectivity between advertisement records 540 and consumer profiling system 500 is via the Internet or other network.

In an alternate embodiment the entities represented in FIG. 5 are located on servers which are interconnect via the Internet or other network.

Consumer profiling system 500 receives purchase information from a point of purchase, as represented by

point of purchase records 510. The information contained within the point of purchase records 510 includes a consumer ID 512, a product ID 514 of the purchased product, the quantity 516 purchased and the price 518 of the product. In
5 a preferred embodiment, the date and time of purchase 520 are transmitted by point of purchase records 510 to consumer profiling system 500.

The consumer profiling system 500 can access the consumer profile 560 to update the profiles contained in it.
10 Consumer profiling system 500 retrieves a consumer characterization vector 562 and a product preference vector 564. Subsequent to retrieval one or more data processing algorithms are applied to update the vectors. An algorithm for updating is illustrated in the flowchart in FIG. 8A. The
15 updated vectors termed herein as new demographic characterization vector 566 and new product preference 568 are returned to consumer profile 560 for storage.

Consumer profiling system 500 can determine probabilistic consumer demographic characteristics based on
20 product purchases by applying heuristic rules 519. Consumer profiling system 500 provides a product ID 514 to heuristic rules records 530 and receives heuristic rules associated with that product. Examples of heuristic rules are illustrated in FIG. 7.

25 In a preferred embodiment of the present invention, consumer profiling system 500 can determine the applicability of an advertisement to the consumer 100. For determination of the applicability of an advertisement, a correlation request 546 is received by consumer profiling
30 system 500 from advertisements records 540, along with consumer ID 512. Advertisements records 540 also provides advertisement characteristics including an ad demographic vector 548, an ad product category 552 and an ad product preference vector 554.

Application of a correlation process, as will be described in accordance with FIG. 8B, results in a demographic correlation 556 and a product correlation 558 which can be returned to advertisement records 540. In a preferred embodiment, advertiser 144 uses product correlation 558 and demographic correlation 556 to determine the applicability of the advertisement and to determine if it is worth purchasing the opportunity. In a preferred embodiment, pricing policy 570 is utilized to determine an ad price 570 which can be transmitted from consumer profiling system 500 to advertisement records 540 for use by advertiser 144.

Pricing policy 570 is accessed by consumer profiling system 500 to obtain ad price 572. Pricing policy 570 takes into consideration results of the correlation provided by the consumer profiling system 500. An example of pricing schemes are illustrated in FIG. 9

FIGS. 6A and 6B illustrate pseudocode for the updating process and for a correlation operation respectively. The updating process involves utilizing purchase information in conjunction with heuristic rules to obtain a more accurate representation of consumer 100, stored in the form of a new demographic characterization vector 562 and a new product preference vector 568.

As illustrated in the pseudocode in FIG. 6A the point of purchase data are read and the products purchase are integrated into the updating process. Consumer profiling system 500 retrieves a product demographics vector obtained from the set of heuristic rules 519 and applies the product demographics vector to the demographics characterization vector 562 and the product preference vector 564 from the consumer profile 560.

The updating process as illustrated by the pseudocode in FIG. 6A utilizes a weighting factor which determines the

importance of that product purchase with respect to all of the products purchased in a particular product category. In a preferred embodiment the weight is computed as the ratio of the total of products with a particular product ID 514
5 purchased at that time, to the product total purchase, which is the total quantity of the product identified by its product ID 514 purchased by consumer 100 identified by its consumer ID 512, purchased over an extended period of time. In a preferred embodiment the extended period of time is one
10 year.

In the preferred embodiment the product category total purchase is determined from a record containing the number of times that consumer 100 has purchased a product identified by a particular product ID.

15 In an alternate embodiment other types of weighting factors, running averages and statistical filtering techniques can be used to use the purchase data to update the demographic characterization vector. The system can also be reset to clear previous demographic characterization
20 vectors and product preference vectors.

The new demographic characterization vector 566 is obtained as the weighted sum of the product demographics vector the demographic characterization vector 562. The same procedure is performed to obtain the new product preference
25 vector 568. Before storing those new vectors, a normalization is performed on the said new vectors. When used herein the term product characterization information refers product demographics vectors, product purchase vectors or heuristic rules, all of which can be used in the
30 updating process. The product purchase vector refers to the vector which represents the purchase of a item represented by a product ID. As an example, a product purchase vector for the purchase of Kellogg's CORN FLAKES in a 32 oz. size has a product purchase vector with a unity value for

Kellogg's CORN FLAKES and in the 32 oz. size. In the updating process the weighted sum of the purchase as represented by the product purchase vector is added to the product preference vector to update the product preference
5 vector, increasing the estimated probability that the consumer will purchase Kellogg's CORN FLAKES in the 32 oz. size.

In FIG. 6B the pseudocode for a correlation process is illustrated. Consumer profiling system 500, after receiving
10 the product characteristics and the consumer ID 512 from the advertisement records retrieves the consumer demographic characterization vector 562 and its product preference vector 564. The demographic correlation is the correlation between the demographic characterization vector 562 and the
15 ad demographics vector. The product correlation is the correlation between the ad product preference vector 554 and the product preference vector 564.

In a preferred embodiment the correlation process involves computing the dot product between vectors. The
20 resulting scalar is the correlation between the two vectors.

In an alternate embodiment, as illustrated in FIG. 10, the basis vectors which describe aspects of the consumer can be used to calculate the projections of the ad vector on those basis vectors. In this embodiment, the result of the
25 ad correlation can itself be in vector form whose components represent the degree of correlation of the advertisement with each consumer demographic or product preference feature. As shown in FIG. 10 the basis vectors are the age of the consumer 1021, the income of the consumer 1001, and
30 the family size of the consumer 1031. The ad characterization vector 1500 represents the desired characteristics of the target audience, and can include product preference as well as demographic characteristics.

In this embodiment the degree of orthogonality of the basis vectors will determine the uniqueness of the answer. The projections on the basis vectors form a set of data which represent the corresponding values for the parameter
5 measured in the basis vector. As an example, if household income is one basis vector, the projection of the ad characterization vector on the household income basis vector will return a result indicative of the target household income for that advertisement.

10 Because basis vectors cannot be readily created from some product preference categories (e.g. cereal preferences) an alternate representation to that illustrated in FIG. 2C can be utilized in which the product preference vector represents the statistical average of purchases of cereal in
15 increasing size containers. This vector can be interpreted as an average measure of the cereal purchased by the consumer in a given time period.

The individual measurements of correlation as represented by the correlation vector can be utilized in
20 determining the applicability of the advertisement to the subscriber, or a sum of correlations can be generated to represent the overall applicability of the advertisement.

In a preferred embodiment individual measurements of the correlations, or projections of the ad characteristics
25 vector on the consumer basis vectors, are not made available to protect consumer privacy, and only the absolute sum is reported. In geometric terms this can be interpreted as disclosure of the sum of the lengths of the projections rather than the actual projections themselves.

30 In an alternate embodiment the demographic and product preference parameters are grouped to form sets of paired scores in which elements in the consumer characterization vector are paired with corresponding elements of the ad characteristics vector. A correlation coefficient such as

the Pearson product-moment correlation can be calculated. Other methods for correlation can be employed and are well known to those skilled in the art.

When the consumer characterization vector and the ad
5 characterization vector are not in a standardized format, a transformation can be performed to standardize the order of the demographic and product preferences, or the data can be decomposed into sets of basis vectors which indicate particular attributes such as age, income or family size.

10 FIG. 7 illustrates an example of heuristic rules including rules for defining a product demographics vector. From the product characteristics, a probabilistic determination of household demographics can be generated. Similarly, the monthly quantity purchased can be used to
15 estimate household size. The heuristic rules illustrated in FIG 7 serve as an example of the types of heuristic rules which can be employed to better characterize consumer 100 as a result of their purchases. The heuristic rules can include any set of logic tests, statistical estimates, or market
20 studies which provide the basis for better estimating the demographics of consumer 100 based on their purchases.

In FIG. 8A the flowchart for updating the consumer characterization vectors is depicted. The system receives data from the point of purchase at receive point of purchase
25 information step 800. The system performs a test to determine if a deterministic demographic characterization vector is available at deterministic demographic information available step 810 and, if not, proceeds to update the demographic characteristics.

30 Referring to FIG. 8A, at read purchase ID info step 820, the product ID 514 is read, and at update consumer demographic characterization vector step 830, an algorithm such as that represented in FIG. 6A is applied to obtain a new demographic characterization vector 566, which is stored

in the consumer profile 560 at store updated demographic characterization vector step 840.

The end test step 850 can loop back to the read purchase ID info 820 if all the purchased products are not yet processed for updating, or continue to the branch for updating the product preference vector 564. In this branch, the purchased product is identified at read purchase ID info step 820. An algorithm, such as that illustrated in FIG. 6A for updating the product preference vector 564, is applied in update product preference vector step 870. The updated vector is stored in consumer profile 560 at store product preference vector step 880. This process is carried out until all the purchased items are integrated in the updating process.

FIG. 8B shows a flowchart for the correlation process. At step 900 the advertisement characteristics described earlier in accordance with FIG. 5 along with the consumer ID are received by consumer profiling system 500. At step 910 the demographic correlation 556 is computed and at step 920 the product preference correlation 558 is computed. An illustrative example of an algorithm for correlation is presented in FIG. 6b. The system returns demographic correlation 556 and product preference correlation 558 to the advertisement records 540 before exiting the procedure at end step 950.

FIG. 9 illustrates two pricing schemes, one for content/opportunity provider 160 based pricing 970, which shows increasing cost as a function of correlation. In this pricing scheme, the higher the correlation, the more the content/opportunity provider 160 charges to air the advertisement.

FIG. 9 also illustrates consumer based pricing 960, which allows a consumer to charge less to receive

advertisements which are more highly correlated with their demographics and interests.

As an example of the industrial applicability of the invention, a consumer 100 can purchase items in a grocery store which also acts as a profiler 140 using a consumer profiling system 500. The purchase record is used by the profiler to update the probabilistic representation of customer 100, both in terms of their demographics as well as their product preferences. For each item purchased by consumer 100, product characterization information in the form of a product demographics vector and a product purchase vector is used to update the demographic characterization vector and the product preference vector for consumer 100.

A content/opportunity provider 160 may subsequently determine that there is an opportunity to present an advertisement to consumer 100. Content/opportunity provider 160 can announce this opportunity to advertiser 144 by transmitting the details regarding the opportunity and the consumer ID 512. Advertiser 144 can then query profiler 140 by transmitting consumer ID 512 along with advertisement specific information including the correlation request 546 and ad demographics vector 548. The consumer profiling system 500 performs a correlation and determines the extent to which the ad target market is correlated with the estimated demographics and product preferences of consumer 100. Based on this determination advertiser 144 can decide whether to purchase the opportunity or not.

Although this invention has been illustrated by reference to specific embodiments, it will be apparent to those skilled in the art that various changes and modifications may be made which clearly fall within the scope of the invention. The invention is intended to be protected broadly within the spirit and scope of the appended claims.

Claims

What is claimed is:

1. A method for profiling a consumer based on consumer purchases, said method comprising the steps of:
 - (a) receiving a computer-readable detailed purchase record of said consumer wherein said computer-readable detailed purchase record has an associated unique consumer identification;
 - (b) retrieving product characterization information;
 - (c) calculating a consumer characterization vector from said computer-readable detailed purchase record and said product characterization information;
 - (d) storing said consumer characterization vector on a computer-readable medium.
2. The method described in claim 1 wherein said consumer characterization vector contains a demographic characterization of said consumer.
3. The method described in claim 1 wherein said consumer characterization vector contains a product preference characterization of said consumer.
4. A method for profiling consumer demographics based on consumer purchases, said method comprising the steps of:
 - (a) receiving a computer-readable detailed purchase record of a consumer wherein said computer-readable detailed purchase record has an associated unique consumer identification, and wherein said computer-readable detailed purchase record contains information regarding the purchase of an item;

- (b) retrieving a demographic characterization vector wherein said demographic characterization vector is retrieved based on said associated unique consumer identification and wherein said demographic characterization vector contains a probabilistic measure of the demographic characteristics of said consumer;
- (c) retrieving a set of heuristic rules wherein said set of heuristic rules contains a probabilistic measure of the demographic characteristics of a purchaser of said item;
- (d) calculating a new demographic characterization vector from said demographic characterization vector and said set of heuristic rules;
- (e) storing said new demographic characterization vector on a computer-readable medium.

5. The method described in claim 4 wherein said set of heuristic rules is in the form of a product demographics vector.

6. The method described in claim 5 wherein said new demographic characterization vector in step (d) is calculated as a weighted average of said product demographics vector and said demographic characterization vector.

7. The method described in claim 6 wherein said weighted average is determined based on a weighting factor, wherein said weighting factor is determined as the ratio of a current product purchase amount to a cumulative product purchase amount.

8. A method for profiling consumer preferences based on consumer purchases, said method comprising the steps of:

- (a) receiving a computer-readable detailed purchase record of a consumer wherein said detailed purchase record has an associated unique consumer identification, and wherein said computer-readable detailed purchase record contains information regarding a purchased item;
- (b) retrieving a product preference vector wherein said product preference vector is retrieved based on said associated unique consumer identification and wherein said product preference vector contains a measure of the characteristics of prior purchases by said consumer;
- (c) creating a product purchase vector from said computer-readable detailed purchase record wherein said product purchase vector contains a representation of at least one feature of said purchased item;
- (d) calculating a new product preference vector from said product preference vector and said product purchase vector;
- (e) storing said new product preference vector on a computer-readable medium.

9. The method described in claim 8 wherein said new product preference vector in step (d) is calculated as a weighted average of said product preference vector and said product purchase vector.

10. The method described in claim 9 wherein said weighted average is determined based on a weighting factor, wherein said weighting factor is determined as the ratio of a

current product purchase amount to a cumulative product purchase amount.

11. A data processing system for profiling a consumer, said data processing system comprising:

- (a) computer processing means for processing data;
- (b) storage means for storing data on a storage medium;
- (c) first means for retrieving a consumer characterization vector;
- (d) second means for receiving a computer-readable detailed purchase record of said consumer wherein said detailed purchase record has an associated unique consumer identification;
- (e) third means for updating said consumer characterization vector based on creating a weighted sum of product characterization information with said consumer characterization vector, wherein an updated consumer characterization vector is stored on said storage medium.

12. The data processing system described in claim 11 wherein said consumer characterization vector contains a demographic characterization of said consumer.

13. The data processing system described in claim 11 wherein said consumer characterization vector contains a product preference characterization of said consumer.

14. A computer program embodied on a computer-readable medium for profiling a consumer based on the purchase of at least one item, said computer program comprising:

- (a) a consumer purchase source code segment for receiving a detailed consumer purchase record wherein said detailed consumer purchase record has an associated unique consumer identification;
- (b) a updating code segment for retrieving a consumer characterization vector and updating said consumer characterization vector based on creating a weighted sum of product characterization information with said consumer characterization vector;
- (c) a storage source code segment for storing said consumer characterization vector on a computer-readable medium.

15. The computer program described in claim 14 wherein said a consumer purchase source code segment for receiving a detailed consumer purchase record supports the reception of said associated unique consumer identification from a network interface.

16. In a networked environment having a plurality of computers interconnected for the purpose of instantaneously transmitting and receiving data, a method for determining the applicability of an advertisement to a consumer, said method comprising the steps of:

- (a) receiving a computer-readable ad characterization vector at a first computer wherein said computer-readable ad characterization vector contains a description of discretionary characteristics

which correspond to a target group for said advertisement;

- (b) receiving a unique consumer ID at said first computer;
- (c) retrieving a consumer characterization vector from storage in said first computer based on said unique consumer ID;
- (d) calculating a correlation factor between said computer-readable ad characterization vector and said consumer characterization vector;
- (e) transmitting said correlation factor from said first computer to a second computer.

17. The method described in claim 16 wherein said consumer characterization vector contains a demographic characterization of said consumer and wherein said computer readable ad characterization vector contains a demographic characterization of the target market for said advertisement.

18. The method described in claim 16 wherein said consumer characterization vector contains a product preference characterization of said consumer and wherein said computer-readable ad characterization vector contains a product preference target market for said advertisement.

19. The method described in claim 16 wherein said correlation factor is calculated as the scalar product of said consumer characterization vector and said ad characterization vector.

20. The method described in claim 16, further comprising the steps of:

- (f) determining a price to present said advertisement, wherein said price is a function of said correlation factor.

21. The method described in claim 20 wherein said price is an increasing monotonic function of said correlation factor.

22. The method described in claim 20 wherein said price is a decreasing monotonic function of said correlation factor.

23. In a networked environment having a plurality of computers interconnected for the purpose of instantaneously transmitting and receiving data, a method for targeting an advertisement to consumers of a specific good, said method comprising the steps of:

- (a) receiving a computer-readable advertisement characterization vector at a first computer wherein said advertisement characterization vector contains a description of a target market, and wherein said description of said target market contains at least one indicator corresponding to a target product;
- (b) receiving a unique consumer ID at said first computer;
- (c) retrieving a consumer characterization vector from a storage unit in said first computer based on said unique consumer ID wherein said consumer characterization vector contains a plurality of purchase indicators, said purchase indicators representing previous purchases of said consumer; and
- (d) calculating a correlation factor between said advertisement characterization vector and said consumer characterization vector;

- (e) transmitting said correlation factor to a second computer.

24. The method described in claim 23, further comprising the steps of:

- (f) determining a price to present said advertisement, wherein said price is a function of said correlation factor.

25. The method described in claim 24 wherein said price is an increasing monotonic function of said correlation factor.

26. The method described in claim 24 wherein said price is a decreasing monotonic function of said correlation factor.

27. A data processing system for determining the applicability of an advertisement to a consumer and for determining a price for displaying said advertisement, said data processing system comprising:

- (a) computer processing means for processing data;
- (b) storage means for storing data on a storage medium;
- (c) first means for receiving an ad characterization vector wherein said ad characterization vector corresponds to said advertisement;
- (d) second means for receiving a unique consumer ID;
- (e) third means for retrieving a consumer characterization vector based on said unique consumer ID;
- (f) fourth means for determining a correlation factor wherein said correlation factor is

determined from the correlation of said ad vector with said consumer characterization vector;

- (g) fifth means for retrieving a pricing function;
- (h) sixth means for determining said price for displaying said advertisement to said consumer wherein said price is determined from said correlation factor and said pricing function.

28. The data processing system described in claim 27 wherein said consumer characterization vector contains a demographic characterization of said consumer.

29. The data processing system described in claim 27 wherein said consumer characterization vector contains a product preference characterization of said consumer.

30. The data processing system described in claim 27 wherein said price is an increasing monotonic function of said correlation factor.

31. The method described in claim 27 wherein said price is a decreasing monotonic function of said correlation factor.

32. A computer program embodied on a computer-readable medium for determining the applicability of an advertisement to a consumer, said computer program comprising:

- (a) an advertisement source code segment for receiving an ad characterization vector;
- (b) a consumer characterization code segment for receiving a unique consumer ID and retrieving

a consumer characterization vector
corresponding to said unique consumer ID;

- (c) a correlating source code segment for
calculating a correlation factor between said
ad characterization vector and said consumer
characterization vector.

33. The computer program described in claim 32. further
comprising:

- (d) a transmitting source code segment for
transmitting said correlation factor.

34. A method for constructing a subscriber characterization
vector and for allowing access to the subscriber
characterization vector without revealing specific viewing
habits, the method comprising the steps of:

- (a) creating a record of the viewing habits of at
least one subscriber in a household;
- (b) determining a subscriber characterization
vector based on the record of the viewing
habits, wherein the subscriber
characterization vector does not contain
specific viewing information; and
- (c) allowing access to the subscriber
characterization vector to determine
applicability of an advertisement.

35. The method of claim 34 wherein access to the subscriber
characterization vector is performed by allowing correlation
of an advertisement characterization vector with the
subscriber characterization vector.

36. A method for constructing a consumer characterization
vector and for allowing access to the consumer

characterization vector without revealing specific purchases, the method comprising the steps of:

- (a) creating a record of purchases;
- (b) determining a consumer characterization vector based on the purchases, wherein the consumer characterization vector does not contain specific purchase information; and
- (c) allowing access to the consumer characterization vector to determine applicability of an advertisement.

37. The method of claim 36 wherein access to the subscriber characterization vector is performed by allowing correlation of an advertisement characterization vector with the consumer characterization vector.

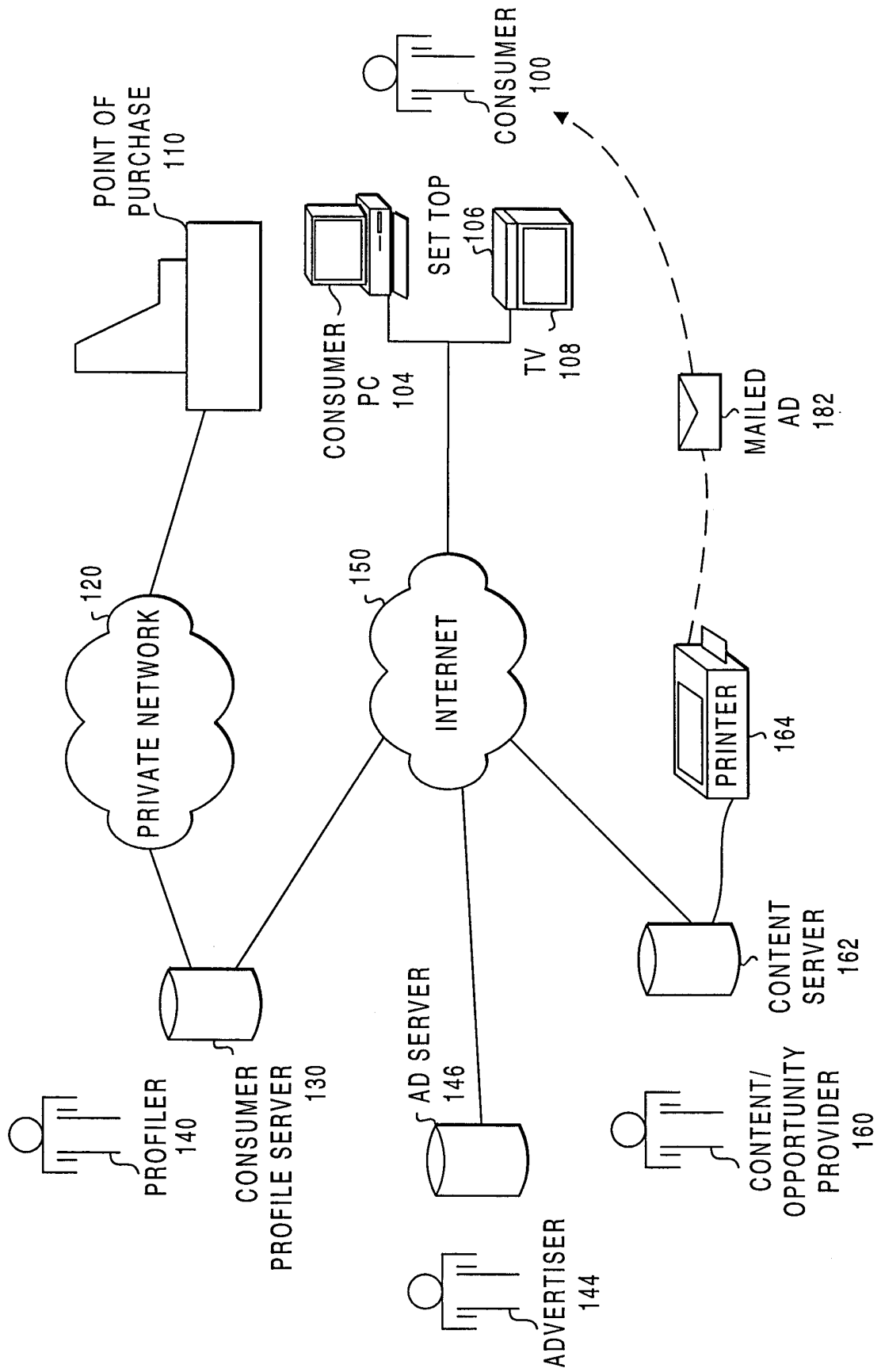

FIG. 1A

2/17

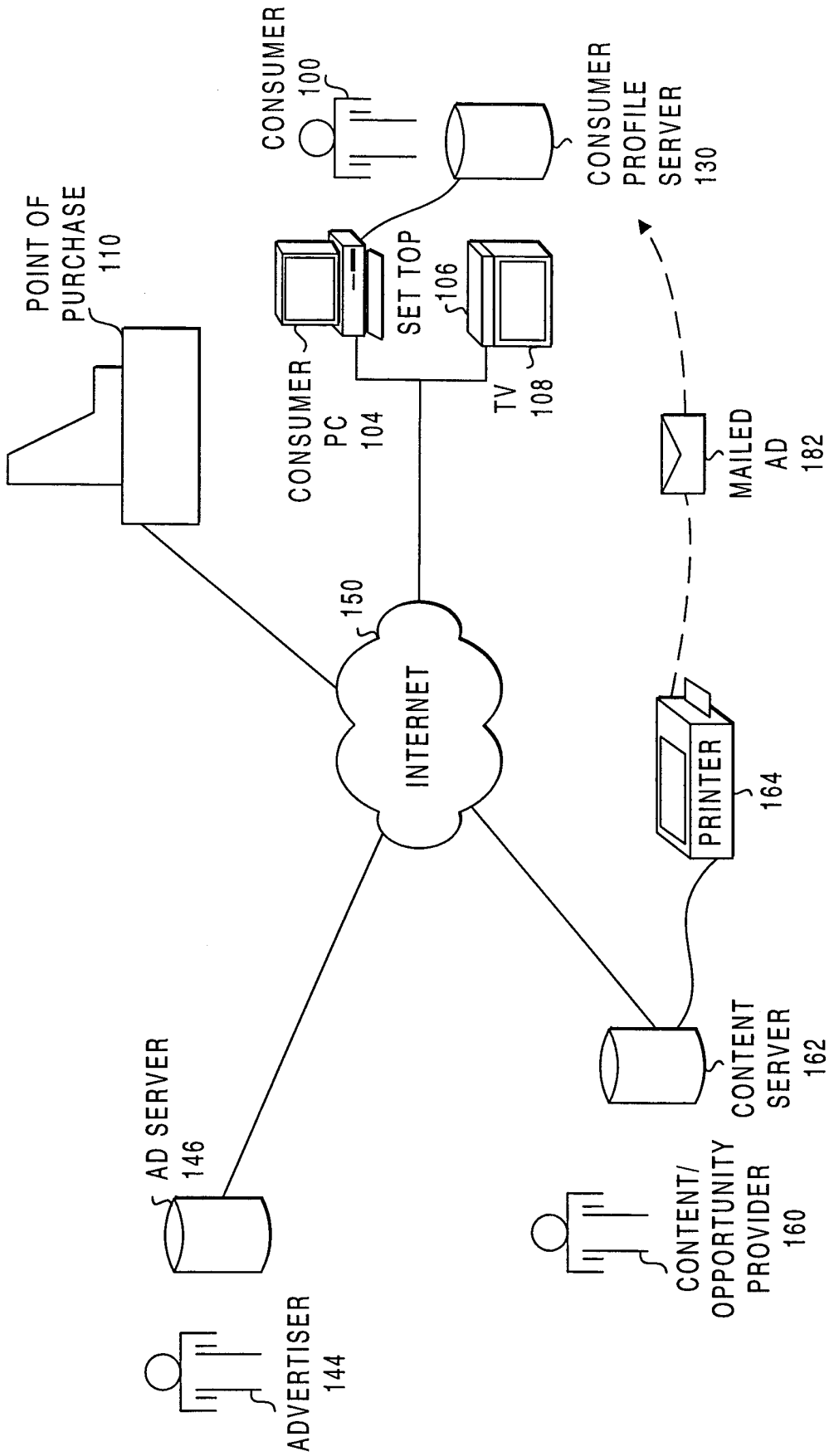

FIG. 1B

3/17

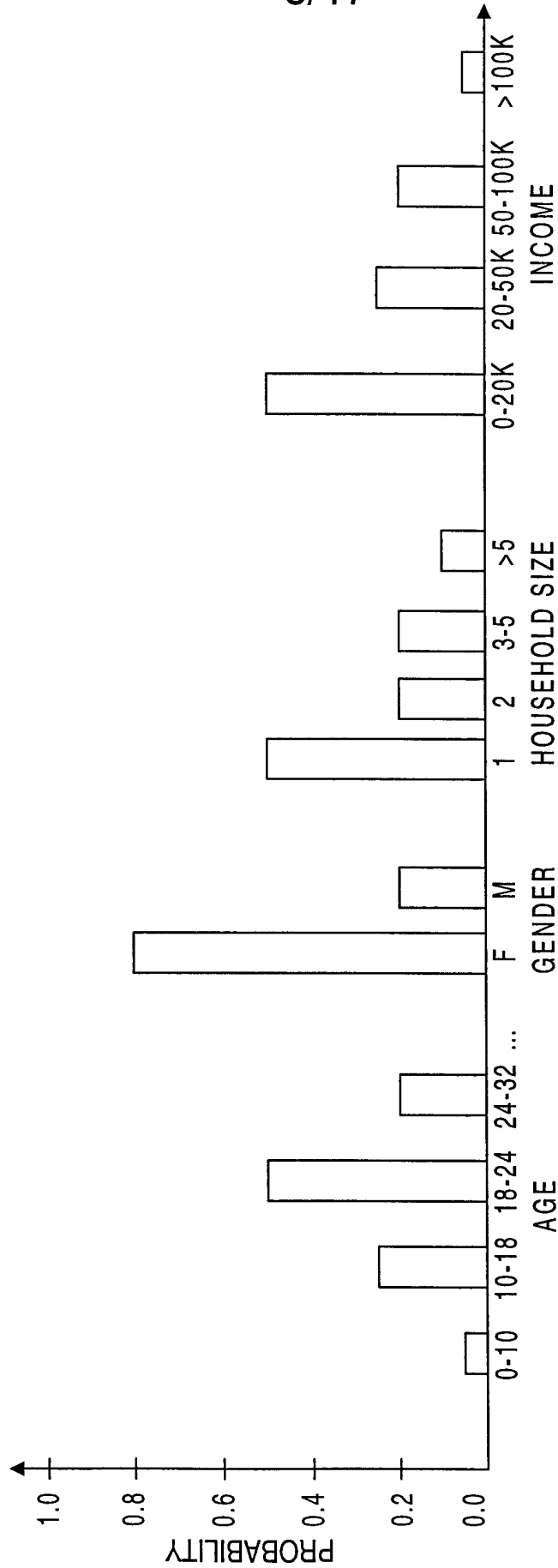

FIG. 2A

4/17

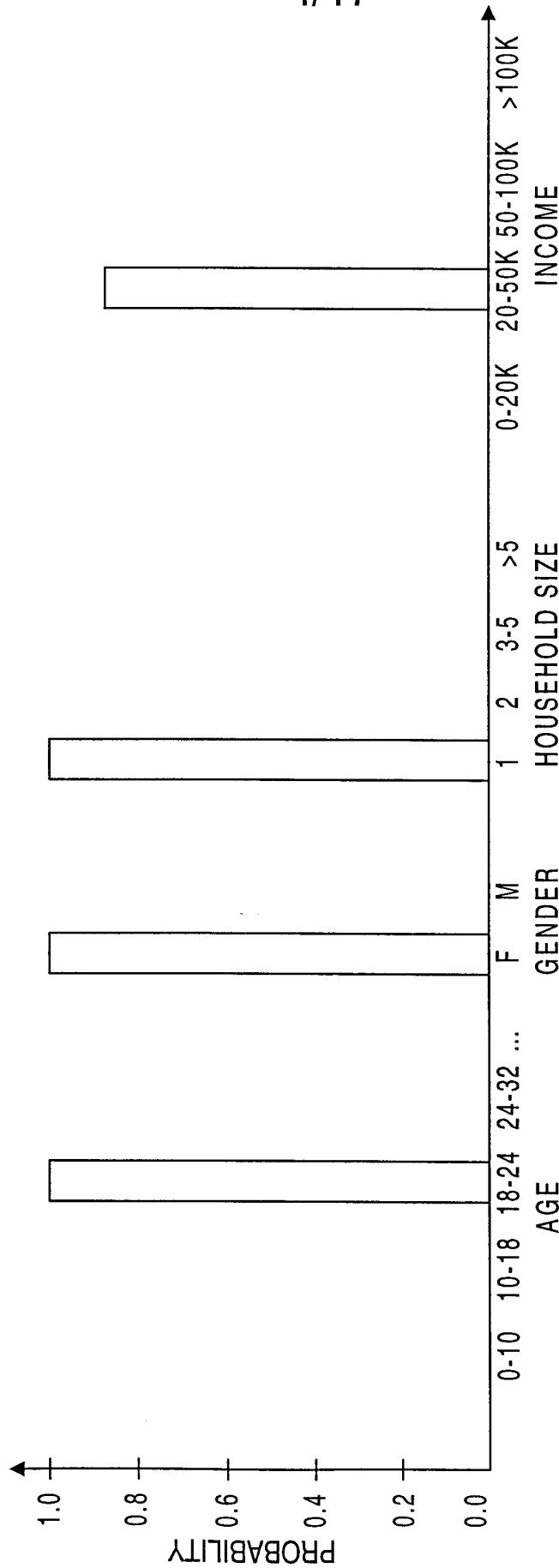

FIG. 2B

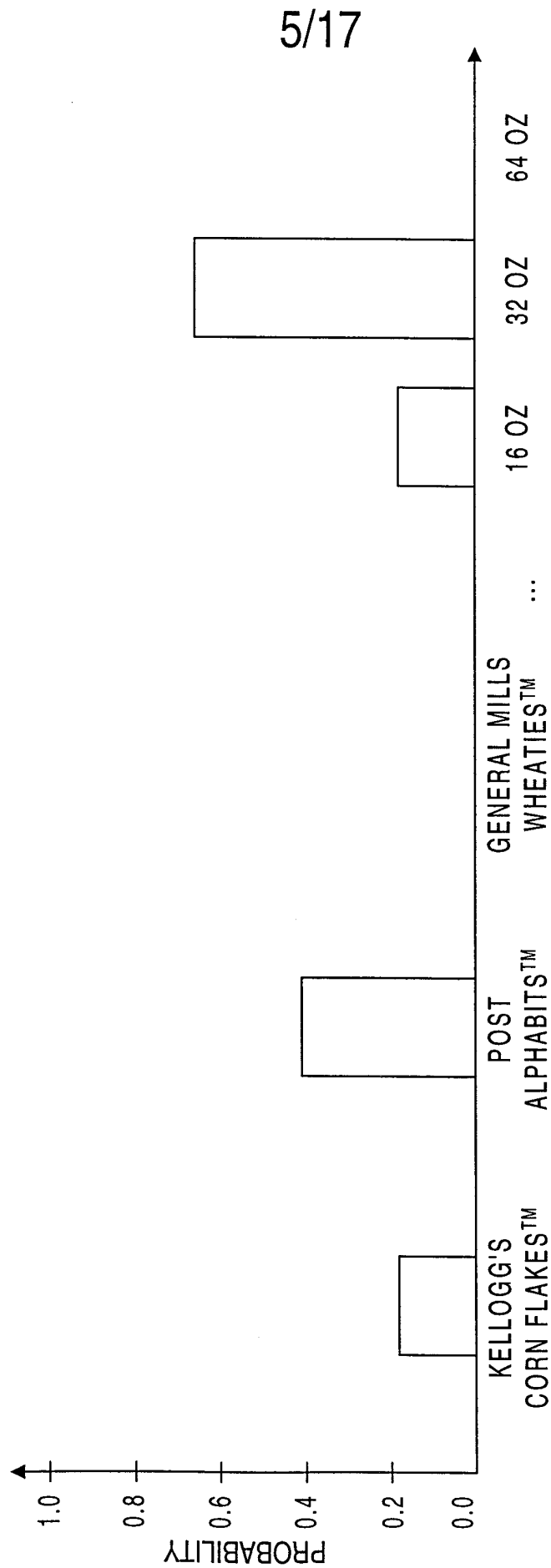

FIG. 2C

6/17

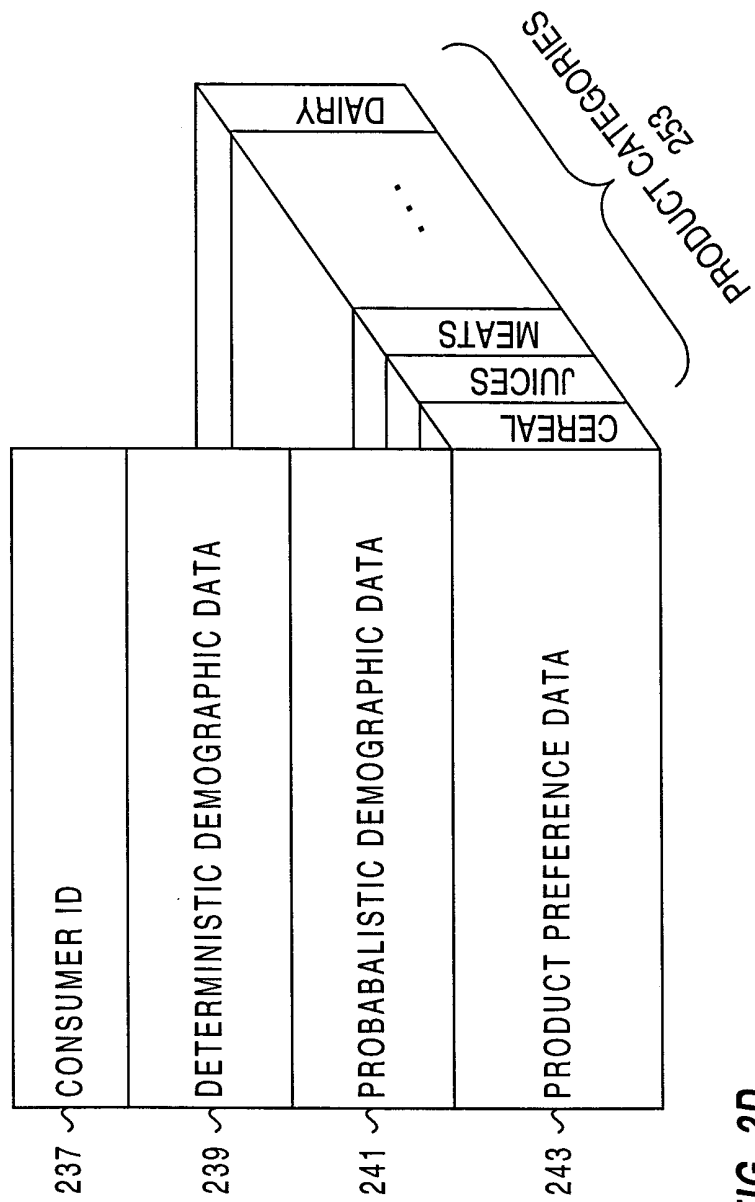

FIG. 2D

7/17

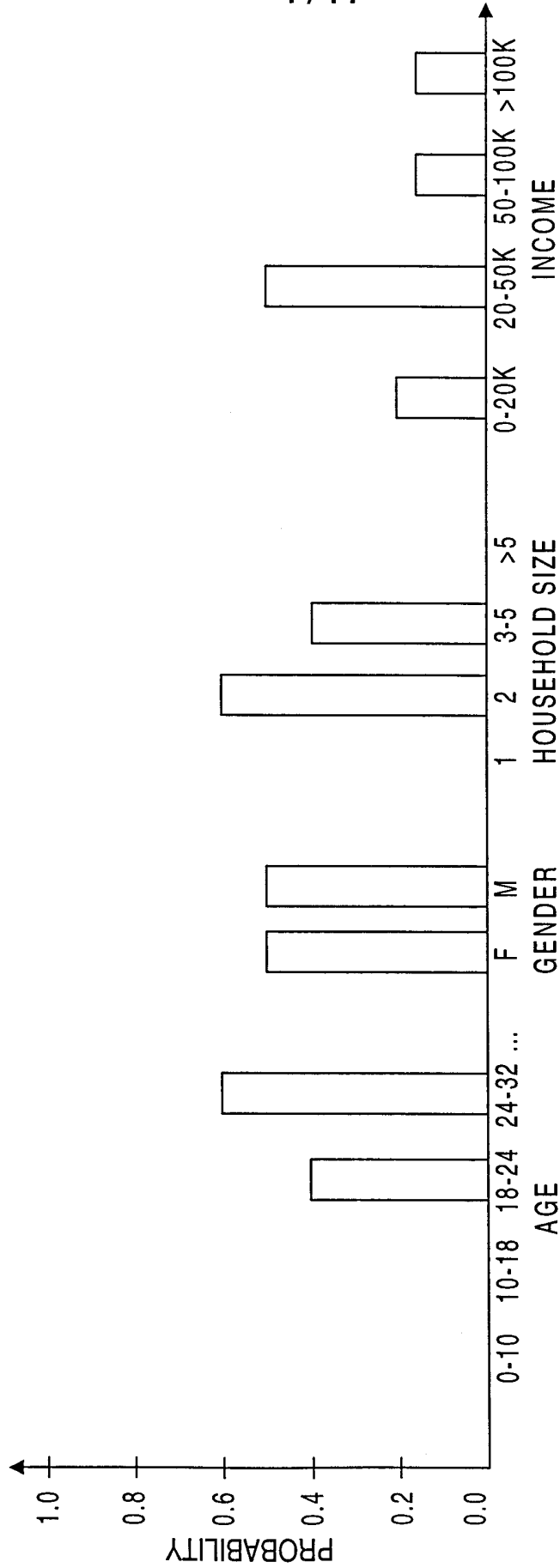

FIG. 3A

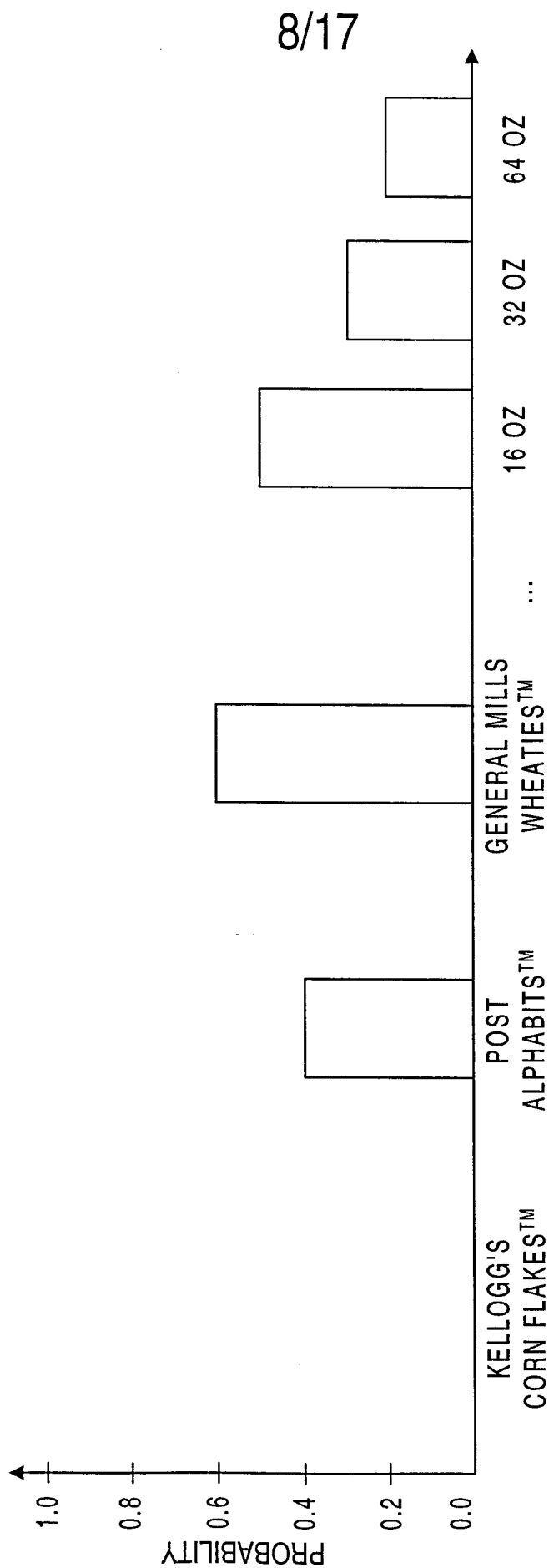

FIG. 3B

9/17

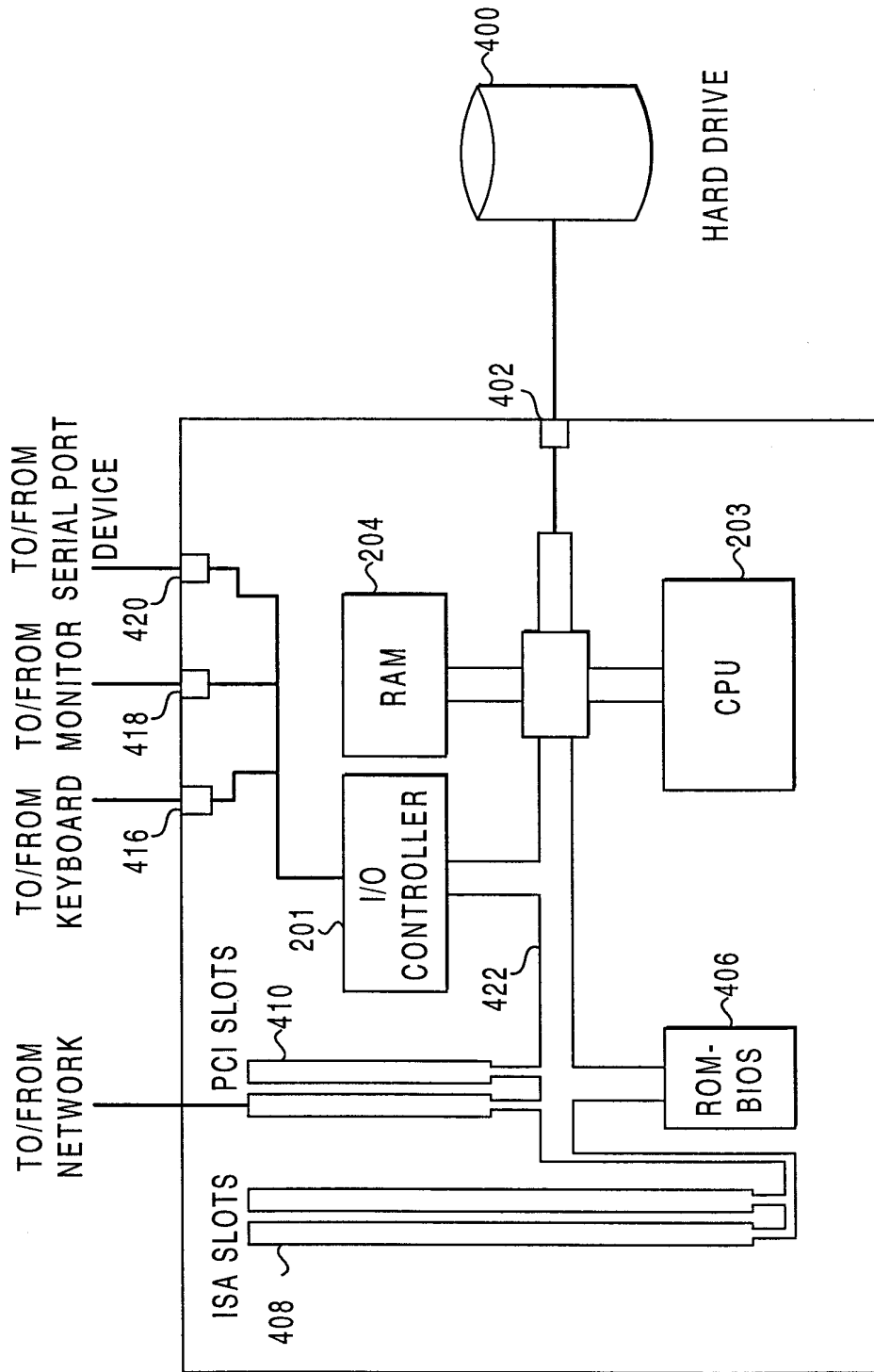

FIG. 4

10/17

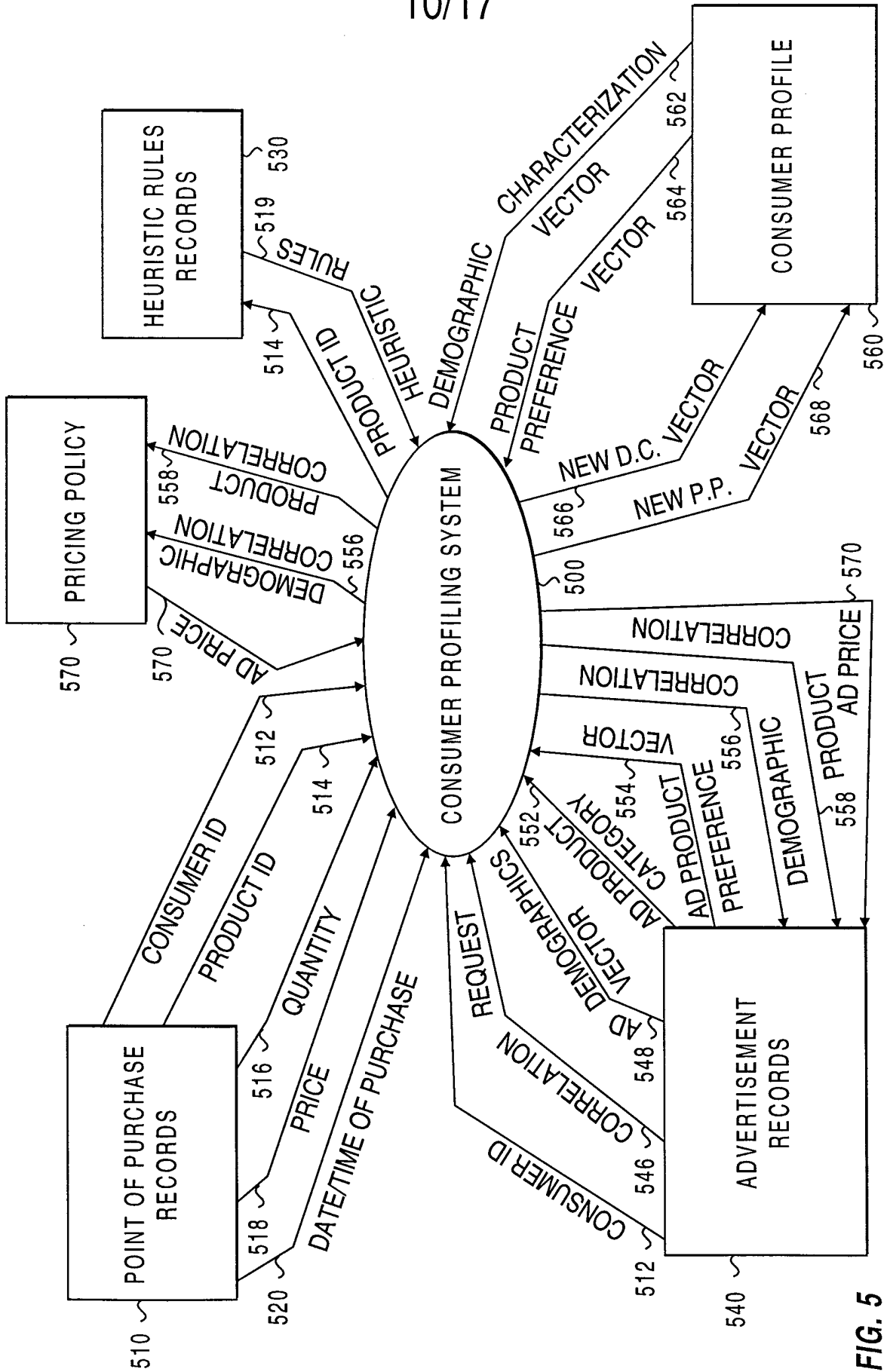

FIG. 5

```

READ POP DATA
  FOR N=1 TO M
    READ PRODUCT ID
    RETRIEVE [PRODUCT DEMOGRAPHICS VECTOR]
    RETRIEVE [DEMOGRAPHIC CHARACTERIZATION VECTOR]
    RETRIEVE [PRODUCT PREFERENCE VECTOR]
    WEIGHT = PRODUCT TOTAL PURCHASE/PRODUCT CATEGORY
            TOTAL PURCHASE
    HOUSEHOLD DEMOGRAPHICS VECTOR =
      (WEIGHT) * (PRODUCT DEMOGRAPHICS VECTOR) +
      (DEMOGRAPHIC CHARACTERIZATION VECTOR)
    NORMALIZE [DEMOGRAPHIC CHARACTERIZATION VECTOR]
    STORE [DEMOGRAPHIC CHARACTERIZATION VECTOR]
    PRODUCT PREFERENCE VECTOR =
      (WEIGHT * PRODUCT PURCHASE VECTOR) + (PRODUCT
        PREFERENCE VECTOR)
    NORMALIZE [PRODUCT PREFERENCE VECTOR]
    STORE [PRODUCT PREFERENCE VECTOR]
  NEXT M

```

FIG. 6A

12/17

```
READ [AD DEMOGRAPHIC VECTOR]
READ [AD PRODUCT CATEGORY, AD PRODUCT PREFERENCE VECTOR]
RETRIEVE [DEMOGRAPHIC CHARACTERIZATION VECTOR]
RETRIEVE [PRODUCT PREFERENCE VECTOR (PRODUCT CATEGORY)]
DEMOGRAPHIC CORRELATION = CORRELATE [DEMOGRAPHIC
CHARACTERIZATION VECTOR, AD DEMOGRAPHIC VECTOR]
PRODUCT PREFERENCE CORRELATION = CORRELATE [AD PRODUCT
PREFERENCE VECTOR, PRODUCT PREFERENCE VECTOR]
RETURN [DEMOGRAPHIC CORRELATION]
RETURN [PRODUCT PREFERENCE CORRELATION]
```

FIG. 6B

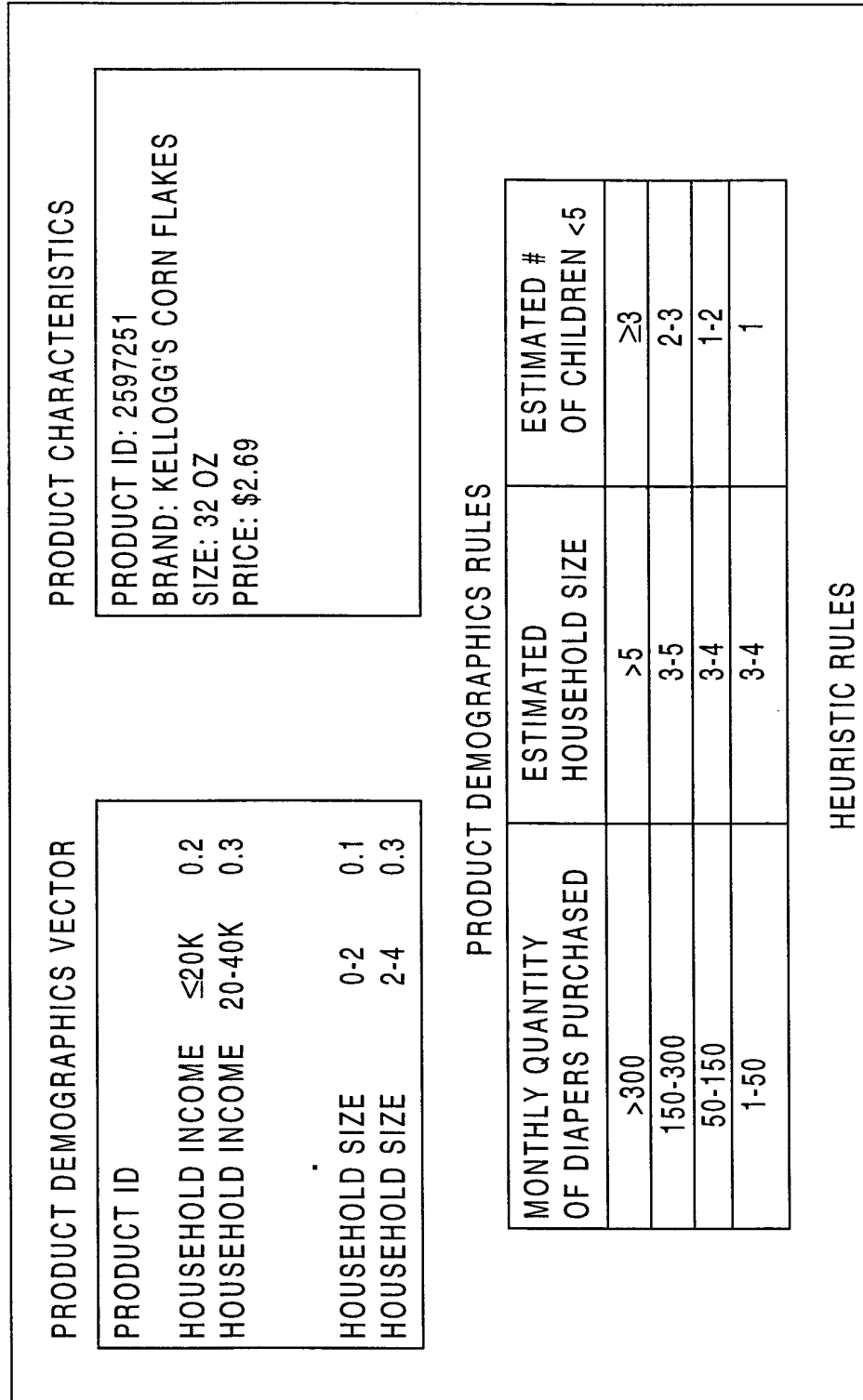

FIG. 7

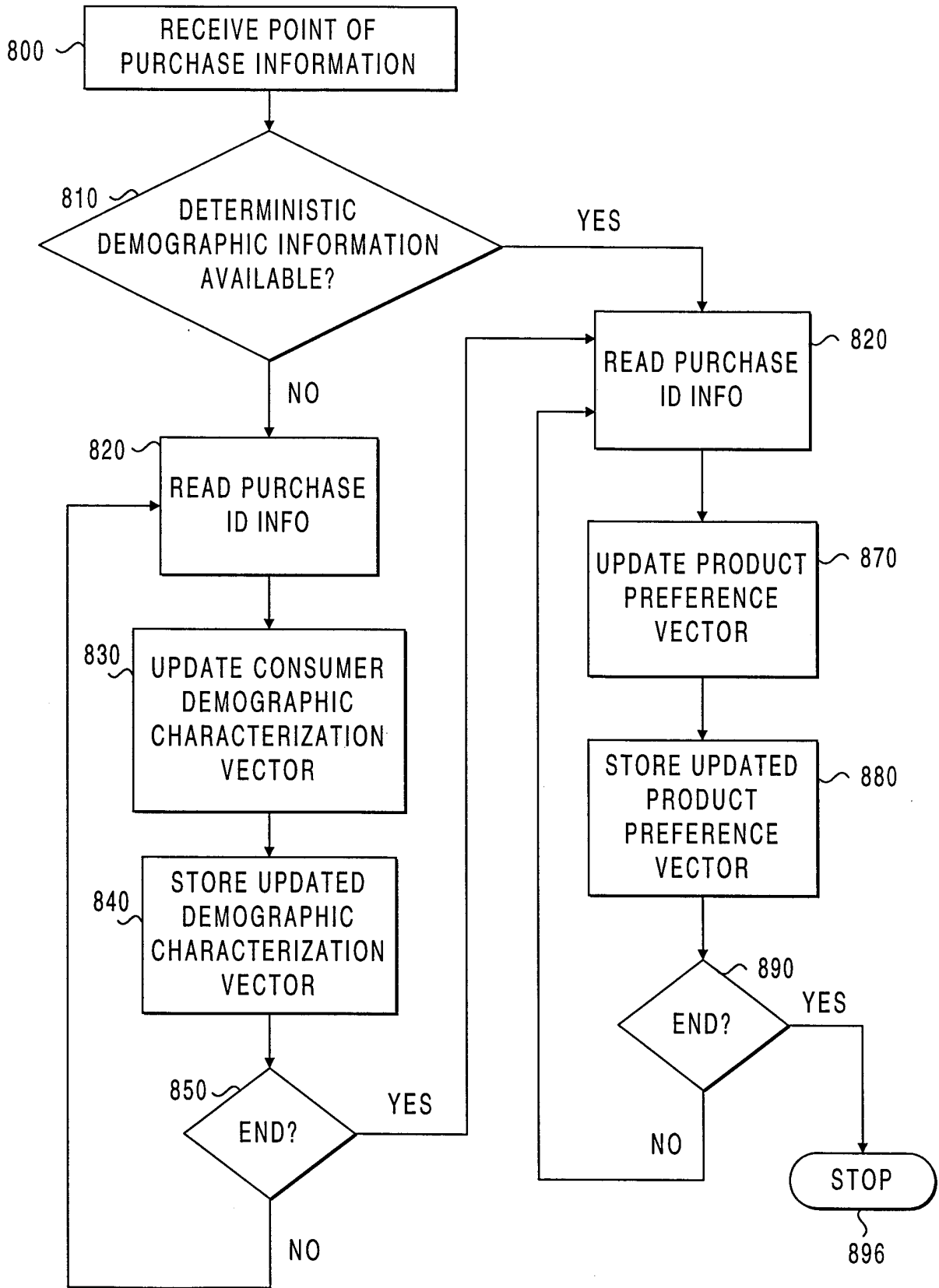

FIG. 8A

15/17

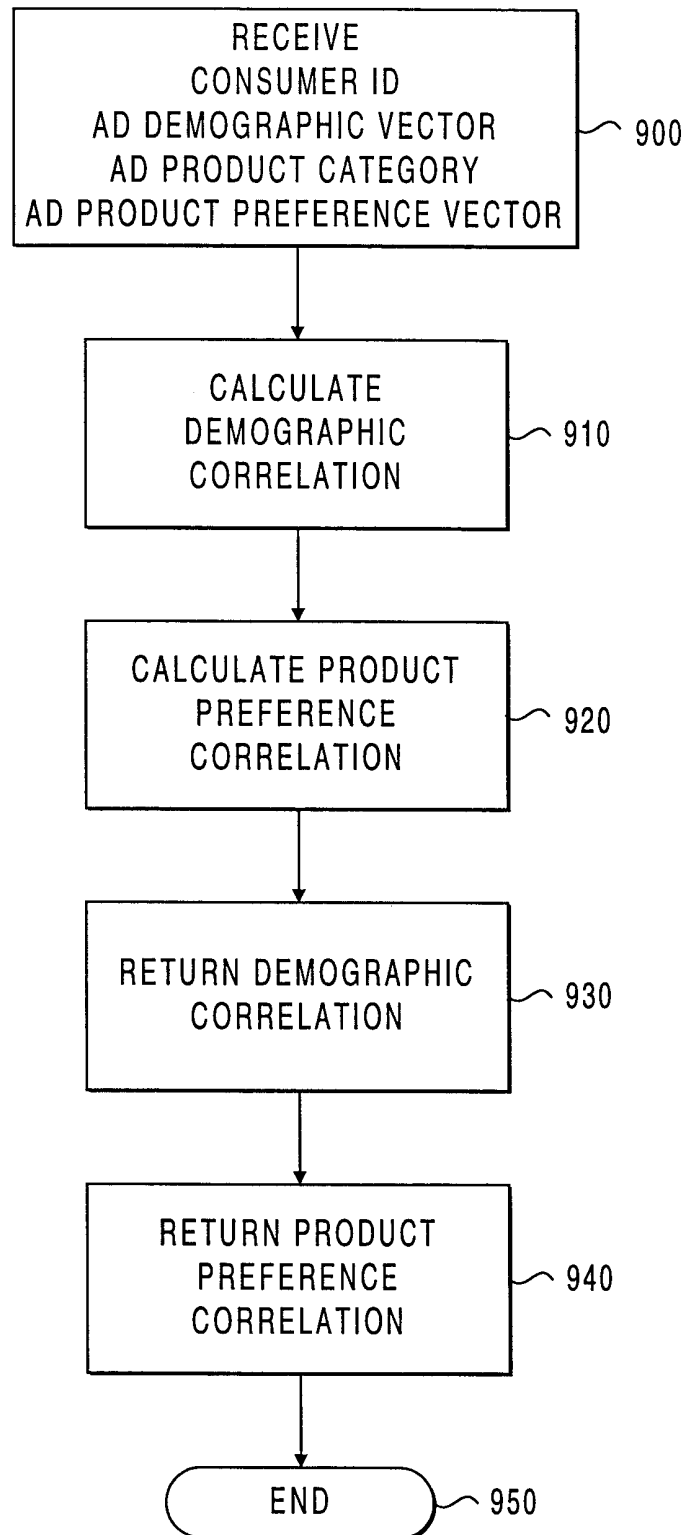

FIG. 8B

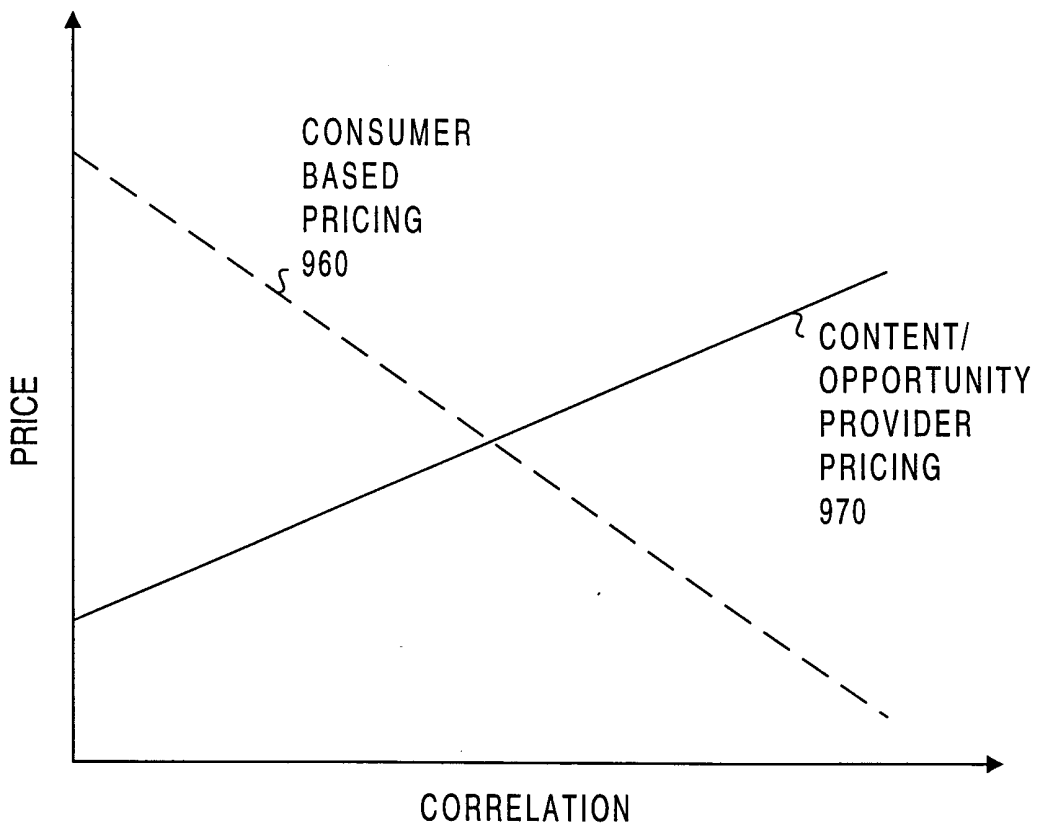

FIG. 9

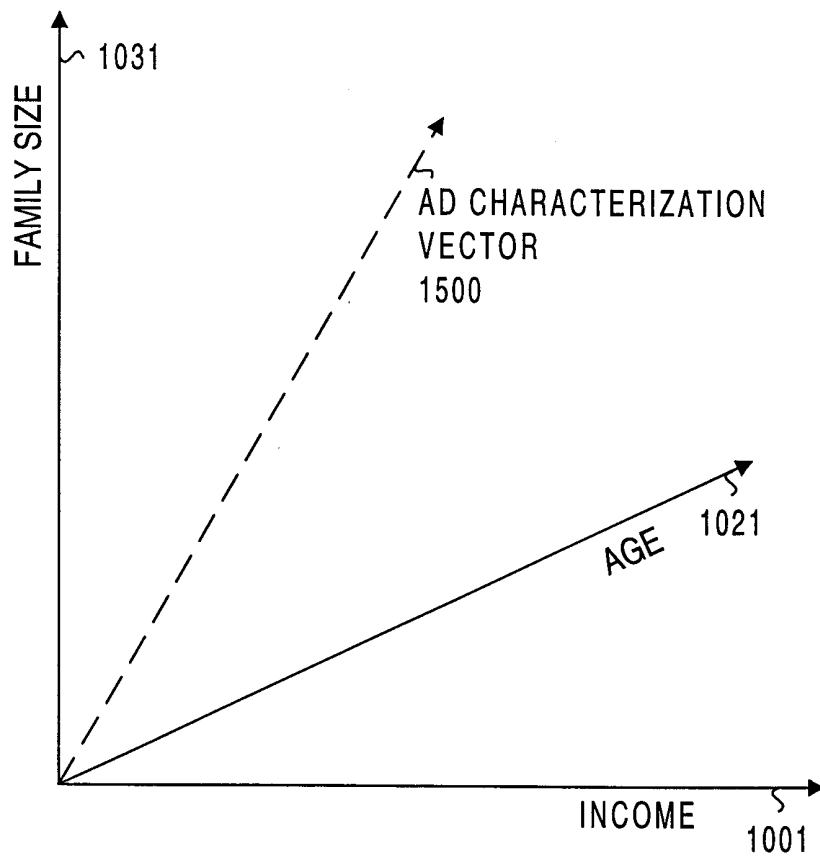

FIG. 10

INTERNATIONAL SEARCH REPORT

International application No.
PCT/US99/28628

A. CLASSIFICATION OF SUBJECT MATTER		
IPC(6) :GO6F 17/60, 17/30, 15/16, 12/00 US CL :707/4, 10, 14, 26; 709/206; 707/4, 10 According to International Patent Classification (IPC) or to both national classification and IPC		
B. FIELDS SEARCHED		
Minimum documentation searched (classification system followed by classification symbols) U.S. : 707/4, 10, 14, 26; 709/206; 707/4, 10		
Documentation searched other than minimum documentation to the extent that such documents are included in the fields searched NONE		
Electronic data base consulted during the international search (name of data base and, where practicable, search terms used) WEST, EAST, IEEE(ONLINE)		
C. DOCUMENTS CONSIDERED TO BE RELEVANT		
Category*	Citation of document, with indication, where appropriate, of the relevant passages	Relevant to claim No.
Y	US 5,724,521 A (DEDRICK) 03 March 1998, col. 19, lines 36-41.	19
Y	US 5,761,662 A (DASAN) 02 June 1998, col. 2, lines 1-54.	1-3, 5-37
Y,P	US 5,978,799 A (HIRSCH) 02 November 1999, col. 1, line 45-col. 3, line 40.	1-18, 20-37
Y	US 5,604,542 A (DEDRICK) 18 February 1997, col. 2, line 34-53.	1-37
T	US 6,009,410 A (LEMOLE et al.) 28 December 1999, col. 1, line 56-col. 2, line 55.	1-37
T	US 6,038,591 A (WOLFE et al) 14 March 2000, col. 1, lines 60-64.	1
<input checked="" type="checkbox"/> Further documents are listed in the continuation of Box C. <input type="checkbox"/> See patent family annex.		
* Special categories of cited documents:	"T"	later document published after the international filing date or priority date and not in conflict with the application but cited to understand the principle or theory underlying the invention
"A" document defining the general state of the art which is not considered to be of particular relevance	"X"	document of particular relevance, the claimed invention cannot be considered novel or cannot be considered to involve an inventive step when the document is taken alone
"E" earlier document published on or after the international filing date	"Y"	document of particular relevance, the claimed invention cannot be considered to involve an inventive step when the document is combined with one or more other such documents, such combination being obvious to a person skilled in the art
"L" document which may throw doubts on priority claim(s) or which is cited to establish the publication date of another citation or other special reason (as specified)	"&"	document member of the same patent family
"O" document referring to an oral disclosure, use, exhibition or other means		
"P" document published prior to the international filing date but later than the priority date claimed		
Date of the actual completion of the international search 23 MARCH 2000	Date of mailing of the international search report 25 APR 2000	
Name and mailing address of the ISA/US Commissioner of Patents and Trademarks Box PCT Washington, D.C. 20231 Facsimile No. (703) 305-3230	Authorized officer Thomas G. Black <i>James R. Matthews</i> Telephone No. (703) 305-9707	

INTERNATIONAL SEARCH REPORT

International application No.
PCT/US99/28628

C (Continuation). DOCUMENTS CONSIDERED TO BE RELEVANT		
Category*	Citation of document, with indication, where appropriate, of the relevant passages	Relevant to claim No.
Y,P	US 5,991,735 A (GERACE) 23 November 1999, col. 2, lines 10-65.	1, 4, 8, 11, 14, 16, 34
Y	US 5,848,396 (GERACE) 08 December 1998, col. 4, lines 1-67.	1, 4, 8, 11, 16, 34
Y,P	US 5,933,811 A (ANGLES et al.) 03 August 1999, see abstract.	1
Y	GALLAGHER et al. A Framework for Targeting Banner Advertising on the Internet, System Sciences, January 1997, Proceedings of the Thirtieth Hawaii International Conference. Vol. 4. pages 265-274.	1, 4, 8, 11, 16, 34
Y	MCCANDLESS. Web Advertising, IEEE Intelligent Systems. June 1998. Vol. 13. pages 8-9.	1, 4, 8
Y	CHANG et al. In Exchange for Consumer Information on the Internet: The Economics and Issues. System Sciences, January 1998., Proceedings of the thirty First Hawaii International Conference. Vol. 4. pages 533-542.	1, 4, 8, 16, 34