

(12) STANDARD PATENT APPLICATION (11) Application No. **AU 2011203135 A1**
(19) AUSTRALIAN PATENT OFFICE

(54) Title
Yaw bearing system

(51) International Patent Classification(s)
F03D 11/00 (2006.01)

(21) Application No: **2011203135** (22) Date of Filing: **2011.06.28**

(30) Priority Data

(31) Number **12/826,036** (32) Date **2010.06.29** (33) Country **US**

(43) Publication Date: **2012.01.19**

(43) Publication Journal Date: **2012.01.19**

(71) Applicant(s)
General Electric Company

(72) Inventor(s)
Hennig, Jens

(74) Agent / Attorney
Phillips Ormonde Fitzpatrick, 367 Collins Street, Melbourne, VIC, 3000

YAW BEARING SYSTEM

ABSTRACT

A wind energy system (100) is provided, with the wind energy system (100) having a tower (110); a machine nacelle (120); a lower yaw bearing (170); and an upper yaw bearing (180); the lower yaw bearing (170) and the upper yaw bearing (180) being arranged to pivotably connect the machine nacelle (120) to the tower (110) of the wind energy system (100).

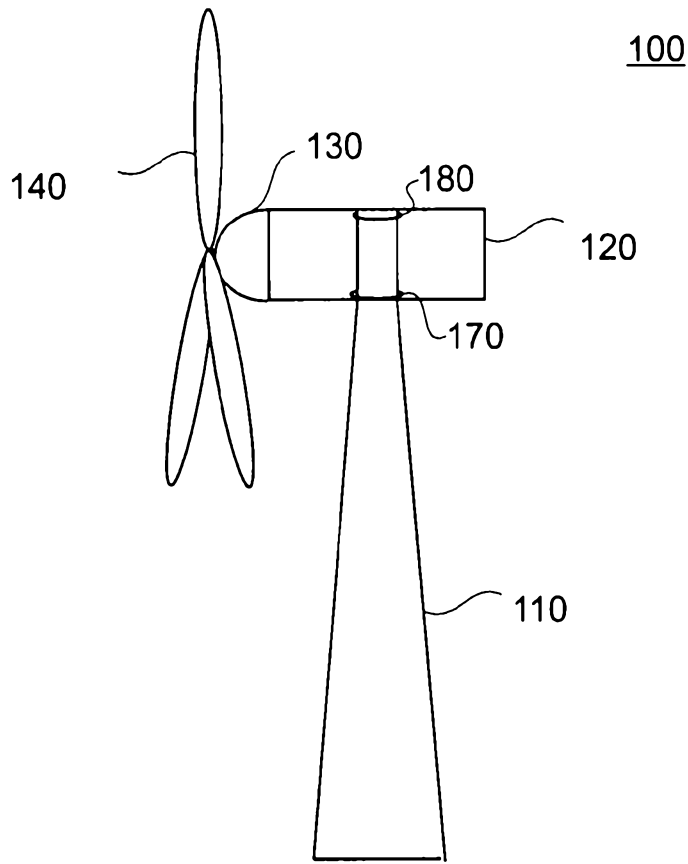

Fig. 2

2011203135 28 Jun 2011

AUSTRALIA

Patents Act

**COMPLETE SPECIFICATION
(ORIGINAL)**

Class Int. Class

Application Number:
Lodged:

Complete Specification Lodged:
Accepted:
Published:

Priority

Related Art:

Name of Applicant:

General Electric Company

Actual Inventor(s):

Jens Hennig

Address for Service and Correspondence:

PHILLIPS ORMONDE FITZPATRICK
Patent and Trade Mark Attorneys
367 Collins Street
Melbourne 3000 AUSTRALIA

Invention Title:

YAW BEARING SYSTEM

Our Ref : 917757
POF Code: 88428/141848

The following statement is a full description of this invention, including the best method of performing it known to applicant(s):

YAW BEARING SYSTEM

[0001] This application claims priority from United States Application No. 12/826,036 filed on 29 June 2010, the contents of which are to be taken as incorporated herewith by this reference.

BACKGROUND OF THE INVENTION

[0002] The present disclosure relates to a wind energy system and a yaw bearing system for a wind energy system.

[0003] Forces and moments from a drive train of a wind energy system to the tower of the wind energy system are guided by a large yaw bearing. The yaw bearing is usually one large wheel with teeth pointing outwards or inwards depending on the location of the yaw drive. The yaw drive is used to orientate the machine nacelle with the drive train relative to the tower.

[0004] Wind energy systems have a nacelle with a bed plate fixed therein. The bed plate is connected to the yaw bearing. Current bed plate designs could possibly identify fatigue problems, especially near the yaw bearing where the forces and the moments have a maximum. Higher warranty costs and lower customer satisfaction are possible consequences. Thus, the connection of the nacelle to the tower of the wind energy system should be improved to reduce fatigue problems, especially with future larger wind turbines.

[0005] A reference herein to a patent document or other matter which is given as prior art is not to be taken as an admission that that document or matter was known or that the information it contains was part of the common general knowledge as at the priority date of any of the claims.

BRIEF DESCRIPTION OF THE INVENTION

[0006] According to an aspect of the present invention, there is provided a wind energy system, with the wind energy system having a tower; a machine nacelle; a lower yaw bearing; and an upper yaw bearing; the lower yaw bearing and the upper yaw bearing being arranged to pivotably connect said machine nacelle to the tower of the wind energy system.

[0007] According to another aspect of the present invention, there is provided a yaw bearing system for use in a wind energy system, with the yaw bearing system having a lower yaw bearing; an upper yaw bearing, the lower yaw bearing and the upper yaw bearing being adapted to pivotably connect a nacelle to a tower of the wind energy system.

[0008] According to a further aspect of the present invention, there is provided a wind energy system, with the wind energy system having a tower; a machine nacelle; and a hub, wherein the hub is rotatably fixed with respect to the machine nacelle; and the tower and the machine nacelle being connected by at least two yaw bearings, wherein one of the yaw bearings is located higher than an axis of rotation of the hub of the wind energy system

[0009] According to a further aspect of the present invention, there is provided a method for operating a wind energy system with a nacelle and a tower, the nacelle and the tower being connected by at least two yaw bearings, the method including the step of rotating the at least two yaw bearings to orientate said nacelle relatively to the tower.

[0010] Further aspects, advantages, details and features that can be combined with embodiments described herein are apparent from the dependent claims, the description and the accompanying drawings.

BRIEF DESCRIPTION OF THE DRAWINGS

[0011] A full and enabling disclosure of the present invention, including the best mode thereof, to one of ordinary skill in the art, is set forth more particularly in the remainder of the specification, including reference to the accompanying figures wherein:

[0012] Fig. 1 is a schematic view of a wind energy system according to embodiments described herein.

[0013] Fig. 2 is a schematic drawing of the wind energy system according to fig. 1, wherein in fig. 2 additional parts are shown.

[0014] Fig. 3 shows schematically parts of another embodiment of a wind energy system in an elevational view.

[0015] Fig. 4 shows schematically additional parts of the embodiment of Fig. 3 in another view.

[0016] Fig. 5 shows schematically parts of a further embodiment of a wind energy system.

[0017] Fig. 6 shows a wire frame model of the parts of the wind energy system illustrated in Fig. 5 according to an embodiment.

[0018] Fig. 7 shows schematically parts of a typical embodiment of a yaw bearing system and a wind energy system according to the present disclosure.

[0019] Fig. 8 shows schematically a further embodiment of a wind energy system.

[0020] Fig. 9 shows schematically a further embodiment of a wind energy system.

DETAILED DESCRIPTION OF THE INVENTION

[0021] Reference will now be made in detail to the various embodiments of the invention, one or more examples of which are illustrated in the figures. Each example is provided by way of explanation of the invention, and is not meant as a limitation of the invention. For example, features illustrated or described as part of one embodiment can be used on or in conjunction with other embodiments to yield yet a further embodiment. It is intended that the present invention includes such modifications and variations.

[0022] Within the following description of the drawings, the same reference numbers refer to the same components. Generally, only the differences with respect to the individual embodiments are described. The structures shown in the drawings are not depicted true to scale but rather serve only for the better understanding of the embodiments.

[0023] Fig. 1 is a schematic view of a wind energy system 100, also referred to as a wind turbine. The wind energy system 100 includes a tower 110 with a machine nacelle 120 mounted at its top end. A hub 130 having three rotor blades 140 is mounted thereto.

[0024] The hub 130 is mounted on a lateral end of the machine nacelle 120. The hub may generally be connected to a generator (not shown) located inside the machine nacelle 120 of the wind energy system 100. The hub is typically rotatable about a horizontal axis.

[0025] Fig. 2 is a schematic view of the wind energy system 100 of fig. 1 showing additional parts. For a better understanding, the body of the machine nacelle 120 is shown transparently in fig. 2. Furthermore, fig. 2 shows a lower yaw bearing 170 and an upper yaw bearing 180. The yaw bearings 170 and 180 connect the machine nacelle 120 to the tower 110.

[0026] Typical embodiments described herein provide two yaw bearings, namely a lower yaw bearing and an upper yaw bearing. The provision of two yaw bearings shares bending moments on two yaw bearings. The yaw bearings of embodiments described herein are fitted in such a way that no or low additional bending moments are created and that the tower and the main frame structure loads are decreased. Typical embodiments show less eccentric load transfer and show material savings due to reduced loads. The yaw bearings are subjected to lower stress and have a reduced complexity. The likelihood of fatigue failure is reduced due to the reduction of forces and bending moments per yaw bearing. The reduction is mainly obtained by the distance between the two yaw bearings. The connection between the tower and the machine nacelle is made stiffer and more reliable due to the provision of two yaw bearings.

[0027] In typical embodiments, the distance between the yaw bearings is at least 50 cm, more typically at least 1 m, even more typical at least 1.5 m. The larger the distance, the smaller are the bending forces acting upon the bearing. Diameters of yaw bearings can be smaller due to smaller forces acting on one yaw bearing. Diameters of yaw bearings according to typical embodiments disclosed herein are smaller than 5.0 m

or 4.0 m or 3.0 m. Moreover, diameters of yaw bearings according to typical embodiments disclosed herein are greater than 50 cm or 1.0 m or 1.5 m.

[0028] Typical embodiments described herein comprise at least one further yaw bearing. Some embodiments have three yaw bearings, one lower yaw bearing, one upper yaw bearing and one in between the upper and the lower yaw bearing. Typically, the middle yaw bearing is positioned substantially in the middle between the upper yaw bearing and the lower yaw bearing. "Substantially" is typically to be understood as embracing a +/-15% deviation from the arithmetic middle. Three yaw bearings or even more yaw bearings provide stiffer connections between the tower of the wind energy system and the machine nacelle.

[0029] In typical embodiments, the hub with the rotor blades is rotating about a horizontal rotation axis. The blades thereby define a plane. It should be noted, that often the blades are not exactly aligned with the "rotor blade plane". Rather, the blades are can be inclined with respect to this plane about a few degrees (approx. 0.5° to 5°) forming an obtuse-angled cone. Typically, the yaw is adapted such that the plane of the rotor blades is aligned perpendicular to the direction of the wind. In embodiments, the rotation axis of the hub with the rotor blades is tilted about some degrees, normally below 10 degrees such as 5 degrees. Herein, the term "essentially horizontal" encompasses an exactly horizontal axis as well as axes which are tilted to a maximum of 8 degrees; 5 degrees; or 2 degrees with respect to a horizontal line.

[0030] According to embodiments described herein, one of the yaw bearings is located higher than the axis of rotation of the hub of the wind energy system. The yaw bearing located higher than the axis of rotation is typically the upper yaw bearing. The lower yaw bearing is typically located below the axis of rotation of the wind energy system. This arrangement provides a good split-up of forces acting on the yaw bearings.

[0031] Fig. 3 shows schematically parts of a typical embodiment of a yaw bearing and a wind energy system. In fig. 3, a shaft 190 is shown which connects the hub 130 with a direct drive generator 195. It should be noted that in fig. 3 many parts have been omitted due to clarity. Some additional parts are shown in fig. 4, wherein in fig. 4 no main frame or hub is shown. Therefore, figs. 3A and 3B are explained together.

[0032] According to embodiments described herein, the shaft is connected to a direct drive generator. Direct drive generators are suitable for machine nacelles with limited space. Direct drive generators do not have a gear box between the hub and the generator. Direct drive generators can easily fit into machine nacelles since no room for a gear box has to be provided.

[0033] In other typical embodiments, the shaft is connected to a gear box which is connected to a generator. It is possible to use gear boxes which only need limited space. Other typical embodiments use small-space combinations of a gear box with a generator to reduce the space needed for the gear box and the generator.

[0034] The yaw bearings 170 and 180 are connected to a main frame 200, wherein the yaw bearings 170 and 180 are connected to different struts of the main frame 200, namely upper and lower struts. The main frame 200 is part of the machine nacelle (not shown in fig. 3 for the sake of clarity) and is designed as a framework which is depicted in fig. 3 in a two-dimensional view. In detail, the machine nacelle is mounted on the outer struts of the main frame 200. The main frame also supports the direct drive generator 195.

[0035] According to typical embodiments described herein, the main frame is designed as a framework, like, e.g. frameworks of common railway bridges having struts which are connected at nodes. Most of the struts are arranged in a parallel manner, such that a construction of the main frame is made easy.

[0036] In further typical embodiments, the main frame is designed as a space frame with a design optimized to reduce forces in different parts of the space frame. Space frames only have few struts arranged in a parallel manner or even no parallel struts. Space frames have struts which mainly follow the trajectories of forces acting on the space frames.

[0037] In fig. 4, a yaw drive 220 is shown which is in engagement with the lower yaw bearing 170. The lower yaw bearing 170 comprises teeth which are in engagement with teeth of the yaw drive 220. The yaw drive 220 can be used to turn the machine nacelle 120 with the main frame 200 around the tower 110. This allows the hub

130 with the rotor blades 140 to be orientated such that the wind energy system 100 is in an optimal position with respect to the wind direction.

[0038] In typical embodiments, one yaw drive is used to align the machine nacelle, the hub and the rotor blades. One yaw drive can be enough for the alignment of the machine nacelle reducing costs of the whole wind energy system. In typical embodiments, a single yaw drive is in engagement with the lower yaw bearing. In further typical embodiments, a single yaw drive is in engagement with the upper yaw bearing. The position of the yaw drive can be chosen in dependence of available space in the nacelle.

[0039] In other typical embodiments described herein, two or more yaw drives are used to align the machine nacelle. Two yaw drives reduce the forces which each yaw drive is subjected to. Typically, one yaw drive is arranged close to a respective yaw bearing, e.g. an upper yaw drive for interacting with the upper yaw bearing and a lower yaw drive for interacting with the lower yaw bearing. According to possible embodiments that can be combined with all embodiments described herein, more than one yaw drive is provided per yaw bearing. Yaw drives can e.g. be hydraulic motors or electromotors.

[0040] The hub 130 rotates about a horizontal rotation axis. The shaft 150 and the generator 160 are normally aligned with the rotation axis. In the embodiment shown in figs. 3A and 3B the wind energy system 100 is configured such that the rotation axis is horizontal.

[0041] According to the embodiment shown in figs. 3A and 3B, the tower reaches through the lower yaw bearing 170. The lower yaw bearing 170 and the upper yaw bearing 180 may be connected by a hollow shaft which is exemplarily shown as hollow shaft 250 in figs. 3A and 3B. The hollow shaft may be an integral part of the tower 110. Hence, a person can pass through the tower 110 through the yaw bearing 170 to get from the lower part of the tower 110 into the hollow shaft 250.

[0042] In typical embodiments, the tower reaches through the lower yaw bearing and ends at the upper yaw bearing. Therefore, the tower forms a hollow shaft between

the lower yaw bearing and the upper yaw bearing. Other typical embodiments described herein use a separated hollow shaft and a flange connection between the tower and the hollow shaft. The flange connection is sited at or nearby the lower yaw bearing.

[0043] In fig.3B, the hollow shaft 250 between the lower yaw bearing and the upper yaw bearing comprises an entry door 260 which can be used to enter the nacelle 120 from the tower 110 and the hollow shaft 250. Moreover, the hollow shaft 250 can be entered from the roof of the nacelle 120 by a roof exit hatch 270 which is located at the upper end of the hollow shaft 250 nearby the upper yaw bearing 180.

[0044] Typical embodiments described herein comprise an entrance or an entry door in the hollow shaft for entering the nacelle from the tower. An entering of the nacelle is made easy. In other embodiments, a simple opening is used to allow a passing from the tower into the nacelle. Between the hollow shaft and the tower a manhole with a manhole cover can be situated. In other embodiments, the tower simply passes through the lower yaw bearing. Typically, one yaw bearing is positioned above the entrance for entering the nacelle from the tower, and one yaw is positioned below the entrance.

[0045] In typical embodiments, inside the tower at the height of the lower yaw bearing struts are provided to stiffen the tower. High forces have to be handled in the area of the lower yaw bearing. Therefore, struts provide for a better guiding of forces from the lower yaw bearing into the tower. Other typical embodiments described herein provide a stiffening plate inside of the hollow shaft to stiffen the hollow shaft at the location of the lower yaw bearing. The stiffening plate may have a man hole.

[0046] Typical embodiments comprise a roof exit hatch on top of the hollow shaft or the upper yaw bearing. The roof exit hatch allows an operator to leave the tower and the hollow shaft to get on top of the machine nacelle. Other embodiments have a roof exit located in the roof of the machine nacelle directed away from the hollow shaft. Typical embodiments have an exit located on one of the side walls of the machine nacelle.

[0047] Fig. 5 shows schematically a typical embodiment of a yaw bearing and a wind energy system according to the present disclosure. In fig. 5, some of the parts

shown in fig. 3 have been omitted for the sake of clarity of the drawing. In detail, the direct drive generator, the shaft connecting the hub to the direct drive generator and some other parts have been omitted.

[0048] The embodiment shown in fig. 5 differs with respect to the embodiment shown in fig. 3 in that the main frame of the wind energy system shown in fig. 5 is designed as a space frame 280. The space frame 280 has several curved struts, such that the outline of the space frame 280 can easily be covered by a shapely hull of the machine nacelle. Moreover, the struts of the space frame 280 are designed for minimal notch stresses reducing fatigue problems. Fig. 5 is a schematical three-dimensional view of a space frame. In fig.6, the space frame is illustrated in more detail as a wire frame model. Further, the internally located yaw bearing, hollow shaft and entry door are schematically shown as well in figs. 5 and 6.

[0049] Typical embodiments comprise a space frame as main frame. Space frames of typical embodiments can provide an improved stiffness. In combination with the two bearings of typical embodiments a greater tower clearance is made possible. A higher tower clearance allows to use less stiffer and hence cheaper rotor blades. Other typical embodiments use three dimensional frames for an improved stiffness.

[0050] Fig. 7 shows schematically parts of a typical embodiment of a yaw bearing system and a wind energy system according to the present disclosure. The embodiment shown in fig. 7 comprises a bed plate 290 which is connected by a lower yaw bearing 170 and an upper yaw bearing 180 to the tower 110. The bed plate 290 is adapted to be connected to the lower yaw bearing 170 and the upper yaw bearing 180. Again, in fig. 7 some parts of the wind energy system 100 have been omitted to show the arrangement of the bed plate 290 and the yaw bearings 170, 180.

[0051] Typical embodiments comprise a bed plate which is connected to the tower by two yaw bearings being arranged with a vertical distance of typically at least 20 cm or 50 cm. Further embodiments comprise three yaw bearings connecting the bed plate with the tower.

[0052] Fig. 8 shows schematically an embodiment of a wind energy system 100. The wind energy system 100 of fig. 8 is a wind energy system having a forward leaning tower top section. The wind energy system 100 comprises a lower yaw bearing

170 and an upper yaw bearing 180. The distance between the two yaw bearings 170, 180 is between 0.2 m and 1.0 m such as 0.5 m to reduce loads on the yaw bearings 170, 180.

[0053] Fig. 9 shows schematically an embodiment of a wind energy system 100. The wind energy system 100 of fig. 9 comprises a lower yaw bearing 170 and an upper yaw bearing 180. The distance between the yaw bearings is between 0.2 m and 1.0 m such as 0.5 m.

[0054] Typical embodiments providing a forward leaning tower top section show a distance between the two yaw bearings of at least 0.5 m. Other embodiments have a distance of at least 1.0 m. A higher distance provides a better split-up of loads.

[0055] Typical embodiments provide a forward leaning tower top section. These embodiments have a greater tower clearance. Furthermore, the stiffness of the rotor blades can be reduced or the length of the rotor blades can be increased due to the greater tower clearance. Furthermore, the cone angle can be reduced. Other typical embodiments use nacelles being arranged in a middle position on top of the tower. Generally, typical embodiments provide a possibility of bigger tower clearance due to their yaw bearing system, which is able to handle higher loads and higher bending moments, especially with respect to the tilt axis. Therefore, typical embodiments can be used for increasing the tower clearance to take measures which increase the AEP (annual energy production) of the wind energy system.

[0056] This written description uses examples to disclose the invention, including the best mode, and also to enable any person skilled in the art to make and use the invention. While the invention has been described in terms of various specific embodiments, those skilled in the art will recognize that the invention can be practiced with modification within the spirit and scope of the claims. Especially, mutually non-exclusive features of the embodiments described above may be combined with each other. The patentable scope of the invention is defined by the claims, and may include other examples that occur to those skilled in the art. Such other examples are intended to be within the scope of the claims if they have structural elements that do not differ from

the literal language of the claims, or if they include equivalent structural elements with insubstantial differences from the literal languages of the claims.

Where the terms “comprise”, “comprises”, “comprised” or “comprising” are used in this specification (including the claims) they are to be interpreted as specifying the presence of the stated features, integers, steps or components, but not precluding the presence of one or more other features, integers, steps or components, or group thereto.

PARTS LIST

100	wind energy system
110	tower
120	nacelle
130	hub
170	lower yaw bearing
180	upper yaw bearing
190	shaft
195	direct drive generator
200	main frame
220	yaw drive
250	hollow shaft
260	entry door
270	roof exit hatch
280	space frame
290	bed plate

THE CLAIMS DEFINING THE PRESENT INVENTION ARE AS FOLLOWS:

1. A wind energy system, with said wind energy system having
a tower;
a machine nacelle;
a lower yaw bearing; and
an upper yaw bearing;
said lower yaw bearing and said upper yaw bearing being arranged to pivotably connect said machine nacelle to said tower of said wind energy system.
2. The wind energy system according to claim 1 wherein said machine nacelle having a main frame, wherein said lower yaw bearing and said upper yaw bearing pivotably connect said main frame to said tower of said wind energy system.
3. The wind energy system according to any one of the preceding claims further comprising at least one yaw drive, said yaw drive being adapted for pivoting said machine nacelle around said tower.
4. The wind energy system according to claim 3 said yaw drive being in engagement with at least one of said upper yaw bearing and said lower yaw bearing.
5. The wind energy system according to any one of the preceding claims further comprising at least two yaw drives, wherein one of said two yaw drives being in engagement with said upper yaw bearing and one of said two yaw drives being in engagement with said lower yaw bearing.
6. The wind energy system according to any of the preceding claims further comprising at least one further yaw bearing.
7. The wind energy system according to any one of the preceding claims wherein a hub having rotor blades being mounted to said machine nacelle and wherein said hub being rotatable around a substantially horizontal rotation axis.

8. The wind energy system according to claim 7 wherein said lower yaw bearing being arranged below said rotation axis and said upper yaw bearing being arranged above said rotation axis.
9. The wind energy system according to any one of the preceding claims wherein said lower yaw bearing and said upper yaw bearing are connected by a hollow shaft.
10. The wind energy system according to any one of the preceding claims wherein said tower continues through said lower yaw bearing, wherein said hollow shaft is part of said tower.
11. A wind energy system substantially as hereinbefore described with reference to any one of the embodiments shown in the drawings.

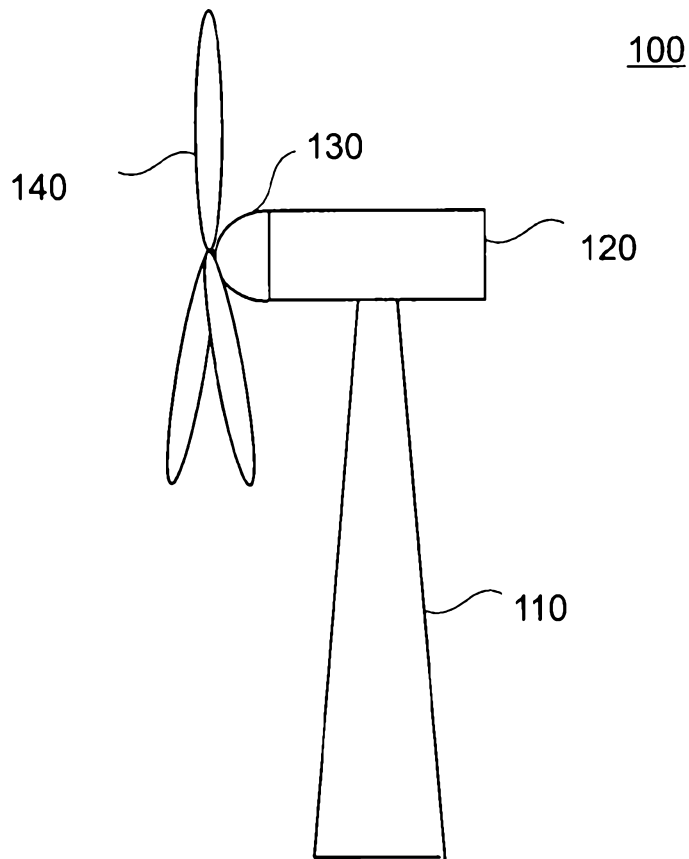

Fig. 1

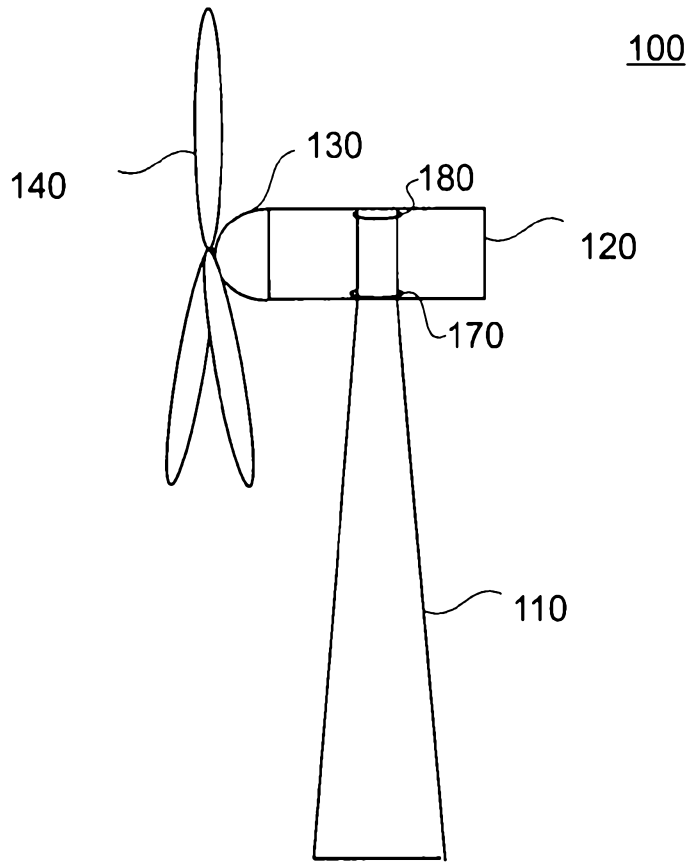

Fig. 2

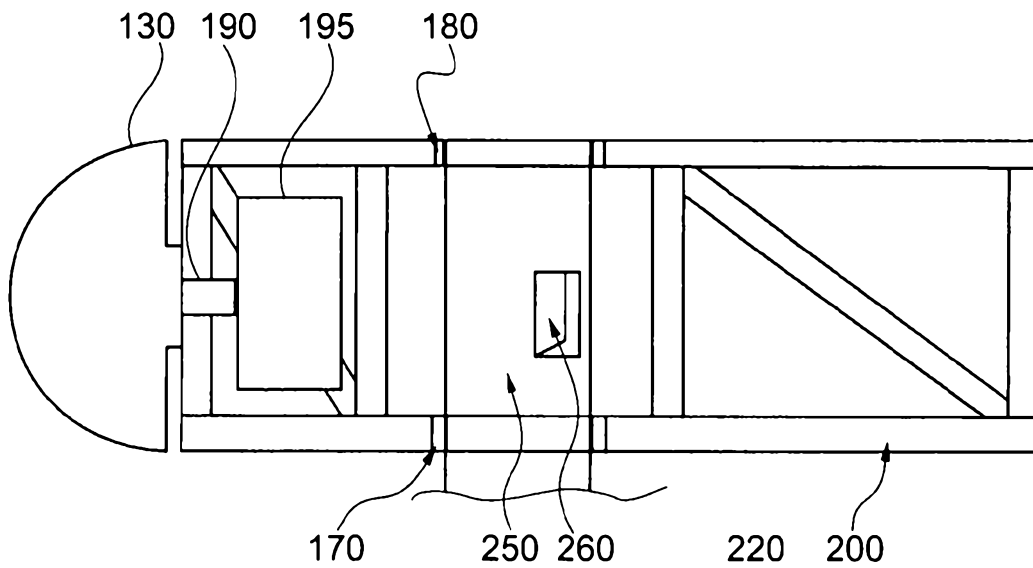

Fig. 3

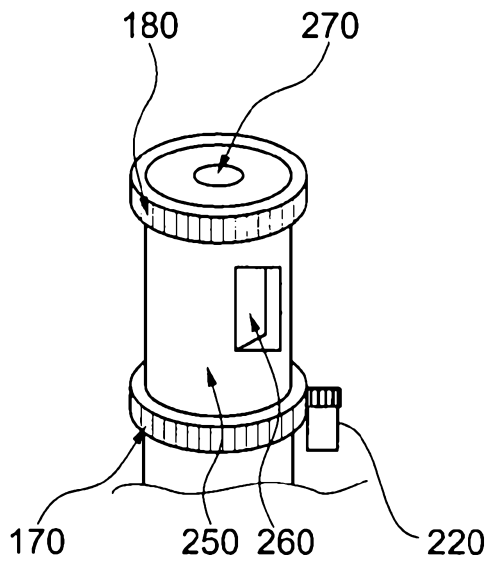

Fig. 4

4/7

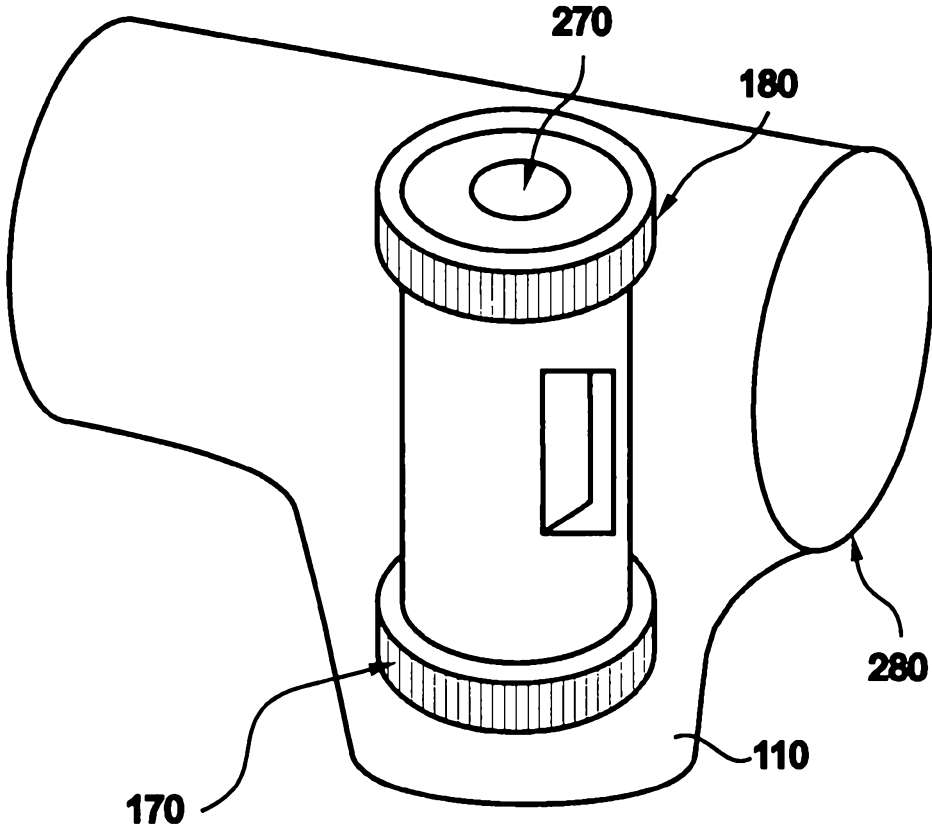

Fig. 5

5/7

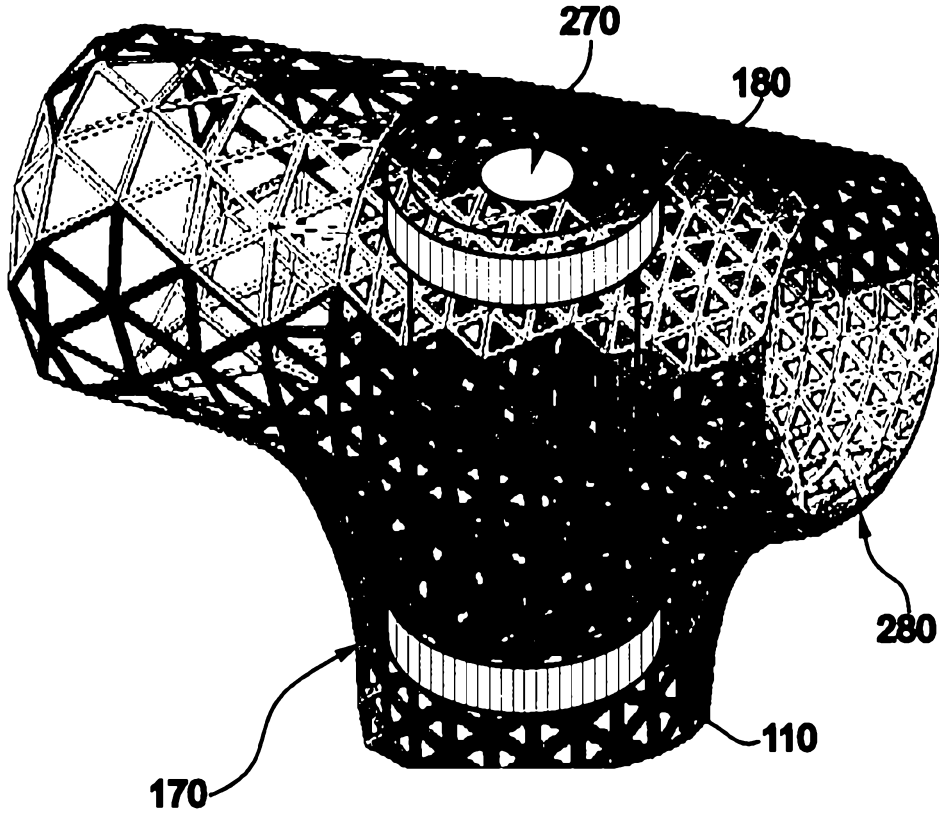

Fig. 6

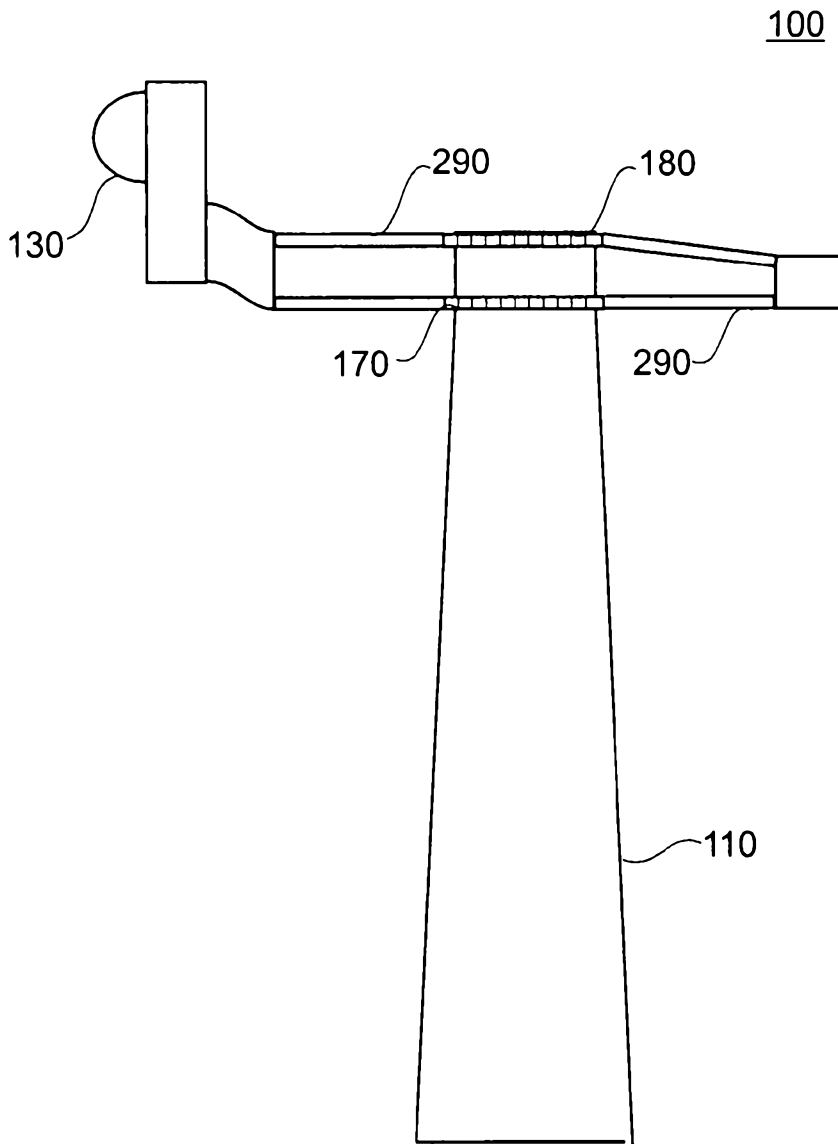

Fig. 7

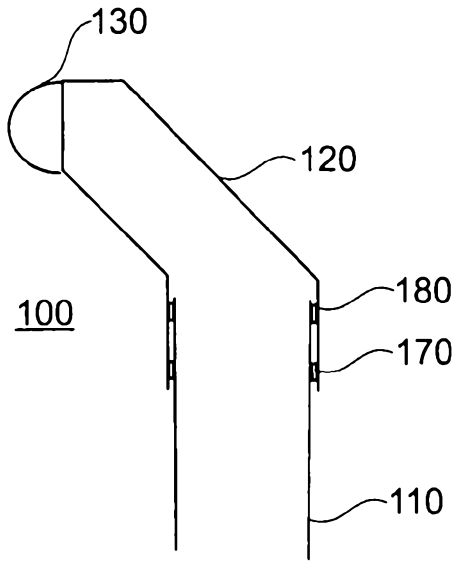

Fig. 8

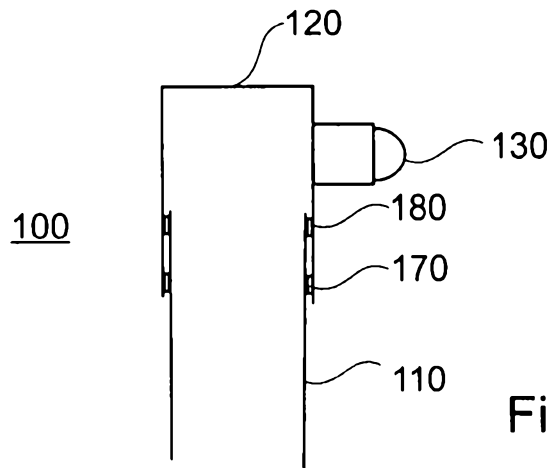

Fig. 9