

(19) World Intellectual Property
Organization
International Bureau



(43) International Publication Date
26 February 2004 (26.02.2004)

PCT

(10) International Publication Number
WO 2004/016420 A1

- (51) International Patent Classification⁷: **B32B 1/08**, 27/32, F16L 9/12, C08L 23/10, 23/00, C08K 5/00
- (21) International Application Number:
PCT/GB2003/003613
- (22) International Filing Date: 19 August 2003 (19.08.2003)
- (25) Filing Language: English
- (26) Publication Language: English
- (30) Priority Data:
0219272.2 19 August 2002 (19.08.2002) GB
- (71) Applicant (for all designated States except US): **UPONOR INNOVATION AB** [SE/SE]; Industrivagen, S-513 81 Fristad (SE).
- (72) Inventor; and
- (75) Inventor/Applicant (for US only): **BOWMAN, Jeremy** [GB/GB]; 171 Somersall Lane, Chesterfield S40 3NA (GB).
- (74) Agent: **HALL, Robert, Leonard**; Harrison Goddard Foote, Fountain Precinct, Balm Green, Sheffield S1 2JA (GB).
- (81) Designated States (national): AE, AG, AL, AM, AT, AU, AZ, BA, BB, BG, BR, BY, BZ, CA, CH, CN, CO, CR, CU, CZ, DE, DK, DM, DZ, EC, EE, ES, FI, GB, GD, GE, GH, GM, HR, HU, ID, IL, IN, IS, JP, KE, KG, KP, KR, KZ, LC, LK, LR, LS, LT, LU, LV, MA, MD, MG, MK, MN, MW, MX, MZ, NI, NO, NZ, OM, PG, PH, PL, PT, RO, RU, SC, SD, SE, SG, SK, SL, SY, TJ, TM, TN, TR, TT, TZ, UA, UG, US, UZ, VC, VN, YU, ZA, ZM, ZW.
- (84) Designated States (regional): ARIPO patent (GH, GM, KE, LS, MW, MZ, SD, SL, SZ, TZ, UG, ZM, ZW), Eurasian patent (AM, AZ, BY, KG, KZ, MD, RU, TJ, TM), European patent (AT, BE, BG, CH, CY, CZ, DE, DK, EE, ES, FI, FR, GB, GR, HU, IE, IT, LU, MC, NL, PT, RO, SE, SI, SK, TR), OAPI patent (BF, BJ, CF, CG, CI, CM, GA, GN, GQ, GW, ML, MR, NE, SN, TD, TG).
- Published:**
— with international search report
- For two-letter codes and other abbreviations, refer to the "Guidance Notes on Codes and Abbreviations" appearing at the beginning of each regular issue of the PCT Gazette.*



WO 2004/016420 A1

(54) Title: PLASTICS PIPE

(57) Abstract: A plastics pipe which comprises an inner core and an outer removable skin layer bonded thereto, the outer removable skin layer comprising a polymeric material, chosen for its physical and mechanical properties, and an adhesion-modifying additive, the adhesion-modifying additive being present in the skin layer in an amount such that the adhesion of the skin layer to the inner core is sufficient to prevent substantial undesired relative movement between the skin layer and the core during installation, but insufficient to prevent the outer skin layer from being cleanly removed by peeling, at least at the ends of the pipe, and insufficient to cause a substantial reduction in the impact strength of the inner core.

PLASTICS PIPE

This invention relates to plastic pipes and more particularly to a novel composite plastics pipe, a method for its manufacture, and a method for making joints in such a pipe.

In the handling, installation and connection of plastics pipes, the pipe surface is easily damaged. In "no-dig" plastics pipe installation techniques, for example, a tunnel is bored in the ground for the pipe and the pipe is then pushed or pulled through the tunnel into an excavated hole where the next pipe joint is to be made. Installation techniques such as pipe-bursting and slip lining can also place extreme stress on the pipe surface.

Other modern pipe laying methods can also subject the pipe to substantial bending and tensile forces, both of which can result in a deterioration of the mechanical strength of the pipe. In addition, the useful life of the pipe may be reduced by diffusible materials in the ground, or by environment conditions, for example, exposure to direct sunlight for long periods.

Of greatest concern, is that modern pipe laying methods can result in the pipe becoming scratched and dirty. This is disadvantageous firstly as the pipe material may be notch sensitive, in which case any scratches may cause greater damage to occur in the pipe during subsequent handling or use. Secondly, dirt and/or oxidation on the pipe surface may prevent successful welding. The main reason for failure of joints using an electrofusion fitting is that the surface of the pipe is

dirty or has become oxidised. For this reason, until recently, the pipe ends always have had to be cleaned and scraped before jointing, for example, with a hand or mechanical scraper. In practice, the cleaning and scraping is often uneven (the underside of the pipe in particular may be treated less carefully), and the quality of the end result depends upon the professional skill of the installer.

In recent years there have been proposals to provide the pipe with a non-adherent skin layer which can be removed in order to permit jointing. Composite pipe constructions of this type are described, for example, in JP3-24392, EP0474583, EPO 604907, GB2323556, GB2300456, and WO93/00212. The entire disclosures of all these patents are incorporated herein by reference for all purposes.

All of these prior art pipe constructions suffer from the disadvantage that modern pipe laying techniques tend to cause wrinkling, rucking, or at least undesired movement of the non-adherent skin layer relative to the core when the pipe is pushed through the ground. These proposals have therefore not proved commercially acceptable.

More traditional proposals, wherein a protective skin layer is provided which is strongly adherent to the pipe, do not, of course, overcome the problem of dirt and oxidation on the outer surface, since such skin layers are very difficult to remove without elaborate equipment. The presence of a tightly adherent skin layer can also dramatically lower the impact strength of the plastics pipe.

The first appreciation that the above problems could be solved by using a protective skin layer which is only lightly adherent to the core pipe occurs in GB2297137 and GB2297138, the entire disclosures of which are incorporated herein by reference for all purposes.

In GB2297138, for example, there is provided a plastics pipe which comprises an inner core and an outer protective layer bonded thereto, in which the dimensions of the pipe and the protective layer are such that the ratio of the external diameter of the pipe to the thickness of the protective layer is at least 70, preferably at least a 100, and the cohesive strength of the outer protective layer, excluding any lines of weakness, at least at the ends of the pipe, is greater than the strength of the adhesive bond between the outer protective layer and the inner core. According to this specification, by a correct choice of the material of the skin layer and the extrusion conditions, it is possible to provide a level of adhesion which still permits clean removal of the skin layer by peeling, whilst preventing rucking or wrinkling of the skin layer during installation and without substantially adversely affecting the mechanical properties of the pipe.

The composite pipe of UK patents GB2297137 and GB2297138 has been commercially extremely successful, but it has been found that under specific conditions of temperature and loading it is difficult to provide a skin layer which has both the required toughness and limited adhesion to the core pipe. Quality control of the base polymer material of the skin layer, and control of the extrusion conditions during manufacture, need to be rigorously maintained if undesirable quantities of scrap are to be avoided. This substantially increases both raw

material and manufacturing costs.

A novel composite plastics pipe has now been developed which has the advantages of a plastics pipe with a removable outer protective layer, but which gives improved flexibility in choice of materials and manufacturing conditions without substantially adversely affecting the mechanical properties of the pipe.

In a first aspect, the invention provides a plastics pipe which comprises an inner core and an outer removable skin layer bonded thereto,

the outer removable skin layer comprising a polymeric material, chosen for its physical and mechanical properties, and an adhesion-modifying additive,

the adhesion-modifying additive being present in the skin layer in an amount such that the adhesion of the skin layer to the inner core is sufficient to prevent substantial undesired relative movement between the skin layer and the core during installation, but insufficient to prevent the outer skin layer from being cleanly removed by peeling, at least at the ends of the pipe, and insufficient to cause a substantial reduction in the impact strength of the inner core.

In a further aspect, the invention provides a method for the production of a plastics pipe comprising an inner core and an outer removable skin layer bonded thereto, the outer removable skin layer comprising a polymeric material chosen for its physical and mechanical properties, and an effective amount of an adhesion-modifying additive, which method comprises co-extruding molten polymeric materials forming the inner core and the

outer removable skin layer from one or more extruder dies, bringing the molten polymeric materials together and allowing them to cool, such that, on cooling, the adhesion of the skin layer to the inner core is sufficient to prevent substantial undesired relative movement between the skin layer and the core during installation of the pipe, but insufficient to prevent the skin layer from being cleanly removed by peeling, at least at the ends of the pipe, and insufficient to cause a substantial reduction in the impact strength of the inner core.

In another aspect the invention provides a method of making a joint to a plastics pipe according to the first aspect of the invention, or of joining two such plastics pipes, which comprises peeling the skin layer from the region or regions of the pipe to be joined, to expose a clean surface suitable for electrofusion jointing, installing an electrofusion fitting over the clean surface or surfaces of the pipe or pipes and activating the electrofusion fitting to fuse the region or regions of the pipe or pipes thereto.

By "undesired relative movement" in this specification is meant movement or de-bonding of the skin layer relative to the core during directional drilling, pipe bursting, slip lining, or other conventional pipe installation procedures.

By selecting the material of the skin layer on the basis of its physical and mechanical properties and then modifying its adhesive properties with an appropriate additive, we have found that it is possible to improve greatly the consistency of the resultant pipe without

sacrificing quality and performance. Thus the properties of the material of the skin layer no longer have to be a compromise between conflicting requirements.

The strength of the adhesive bond between the skin layer and the inner core is preferably at least 0.1 N/mm, more preferably at least 0.2 N/mm, when measured by a rolling drum peel test as described in Appendix 1. The adhesive bond between the skin layer and the inner core is preferably less than 2.0 N/mm, more preferably less than 1.5 N/mm. Very good results have been achieved using an adhesion between the skin layer and the inner core within the range of from 0.3 to 1.5 N/mm, when measured by the above-mentioned rolling drum peel test. Without wishing to be bound to any particular theory, it is believed that the adhesion between the high molecular weight polymers of the inner bonding layer and the core is as a result of Van der Waals and/or diffusive bonding, or similar forces.

It is likely that any adhesion between the skin layer and the inner core will have some effect upon the impact strength of the plastics pipe, and it is presumably for this reason that prior art proposals (other than GB2297137 and GB2297138) have always sought to avoid adhesion between the skin layer and the core. Nevertheless, it has been found that the combination of the tough skin layer and the light bonding used in the present invention can still produce a plastics pipe having sufficient impact strength to meet the requirements of all available standards. Moreover improved impact strength over the products of GB2297137 and GB2297138 can also be obtained. Preferably the strength of the adhesive bond between the skin layer and the inner core is such that the impact strength of the

composite plastics pipe is at least 50%, preferably at least 75%, more preferably at least 90% of the impact strength of the inner core without the skin layer.

The inner core and the skin layer of the composite plastics pipe of the present invention can comprise any suitable thermoplastic polymeric materials, consistent with the maintenance of the required properties. Suitable polymeric materials include, for example, olefinically-unsaturated polymers and co-polymers, for example, polyolefins such as polyethylene, polypropylene, polybutene and polybutylene; ethylene and propylene co-polymers, for example, ethylene-vinyl acetate polymers, and propylene-vinyl acetate polymers; halogenated-vinyl polymers such as vinyl chloride polymers and co-polymers; polyamides, for example, nylon 6, nylon 11 and nylon 66; polycarbonates; ABS polymers and ionomer polymers such as Surlyn (RTM).

The inner core of the pipe comprises a polymeric material chosen to be compatible with the particular application, and in particular with the fluid material to be conveyed by the pipe. For many applications polyethylene is the preferred material for the inner core. The grade of polyethylene chosen, that is to say, high density, medium density, low density, or linear low density, will depend upon the particular application. Suitable grades of polyethylene for pressure pipe applications, preferably meet the requirements of at least one of prEN 12201-1 (except clause 4.2.1 and the associated pigment or carbon black requirements if an unpigmented material is used), prEN12201-2 (except clause 5.2 and the associated pigment or carbon black requirements if an unpigmented material is used), prEN1555-1 (except clause 4.2.2 and the associated

pigment or carbon black requirements if an unpigmented material is used) and prEN1555-2 (except clause 5.2 and the associated pigment or carbon black requirements if an unpigmented material is used).

Any suitable equivalent grade of polyethylene may, of course, also be used.

The skin layer is formed from a polymeric material or a blend of polymeric materials having good mechanical and physical properties, especially toughness and low temperature impact strength. Preferred polymeric materials for the skin layer comprise propylene homo- and co-polymers, propylene block co-polymers, and propylene random co-polymers. Preferably the skin layer has a notched Charpy impact strength of at least 1 kJ/m², more preferably at least 2 kJ/m² and most preferably at least 4 kJ/m², when measured using the method of ISO 179/16A at a temperature of -20°C.

Under typical co-extrusion conditions, many polymer material combinations tend to adhere strongly together, and this is generally true for many grades of polyethylene and propylene polymers. In this specification, polymeric materials of the skin layer are termed "adherent polymeric materials", if, but for the presence of the adhesion reducing additive, they would adhere to the core pipe to an extent such that the outer skin layer cannot be peeled from the core pipe, or such that the impact strength of the composite plastics pipe is substantially reduced, or both, when the core pipe and the skin layer are extruded under typical extrusion conditions. In such cases the skin layer will need to comprise an appropriate amount of an adhesion-reducing additive.

The quantity of adhesion-reducing additive in the polymeric material of the skin layer is preferably such that the adhesion to the inner core is below 2.0N/mm and preferably below 1.0N/mm when measured using a rolling drum peel test as described in Appendix 1. The actual quantity of adhesion-reducing additive in the skin layer depends on the additive used, but in general is within the range of from 0.0001% to 15% by weight, more preferably from 0.5% to 10% by weight and most preferably from 1.0% to 8% by weight.

The adhesion-reducing additive is desirably one that has little or no effect on the mechanical and physical properties of the polymeric material of the skin layer. Preferred adhesion-reducing additives include esters, and, for example, one class of preferred esters includes esters of polyhydric alcohols such as ethane-1,2-diol, 2,2-dimethyl-1,3-propanediol (neopentyl glycol), 2-methyl-2-propyl-1,3-propanediol, 2-butyl-2-ethyl-1,3-propanediol, 2-butyl-2-methyl-1,3-propanediol, 1,3-propanediol, 2-methyl-1,3-propanediol, 1,2-pentanediol, 1,6-hexanediol, 3-hexyne-2,5-diol, 2,5-dimethyl-3-hexyne-2,5-diol, 1,10-decanediol, 2,2-bis(4-hydroxycyclohexyl)propane, 1,4-bis(hydroxymethyl)cyclohexane, 2,2,4-trimethyl-1,3-pentanediol, glycerol (propane-1,2,3-triol), trimethylolethane, trimethylolpropane, ditrimethylolpropane, pentaerythritol, dipentaerythritol, tripentaerythritol, sorbitol and mannitol.

Another class of preferred esters includes esters of fatty acids such as decanoic acid, docosanoic acid, dodecanoic acid (lauric acid), hexadecanoic acid (palmitic acid), octadecanoic acid, octanoic acid

(caprylic acid), oleic acid, linoleic acid, linolenic acid, octadecanoic acid (stearic acid), behenic acid, erucic acid, myristic acid, nonanoic acid, and ricinoleic acid.

Examples of preferred esters of polyhydric alcohols include glycerol esters with erucic acid, stearic acid, lauric acid, linoleic acid, myristic acid, oleic acid, palmitic acid, ricinoleic acid and behenic acid. Particularly good results have been achieved with glycerol mono - stearate, which is one of the most preferred adhesion-reducing additives for use in the present invention.

Examples of preferred esters of fatty acids include hexadecanoic acid, 2, 3,-bis [(trimethylsilyl)oxy] propyl ester and octadecanoic acid, 2, 3,-bis [(trimethylsilyl)oxy] propyl ester.

Another class of preferred esters includes cyclic esters of hydroxycarboxylic acids, for example, γ -butyrolactone, which is the cyclic ester of 4-hydroxybutyric acid.

Yet another class of preferred adhesion reducing additives includes acid anhydrides, for example, propanoic acid 2-methyl anhydride.

A still further class of adhesion-reducing additives that can be used includes fatty acid amides, for example oleamide, stearamide, erucamide, behenamide and ethylene - bis - stearamide. Excellent results have been obtained using stearamide, erucamide and ethylene - bis - stearamide, and these are further examples of most preferred adhesion-reducing additives for use in the

present invention.

Yet another class of adhesion-reducing additives that can be used includes ethoxylated amines and esters.

Yet another adhesion-reducing additive that can be used is polybutylene.

Mixtures of any of the abovementioned adhesion-reducing additives may be used where compatible in any suitable combinations, proportions and amounts.

A particularly preferred plastics pipe according to the present invention comprises an inner core of polyethylene and a skin layer of a propylene block copolymer comprising from 2% to 4% of a glycerol ester as an adhesion-reducing additive.

Preferably the impact strength of a 90 mm outside diameter plastics pipe having a polyethylene inner core and a polypropylene skin layer with an SDR of 17.0 is greater than 300 joules when measured using the method of EN1411:1996 at a temperature of -10°C using a 90mm diameter tup for impacting the pipe.

The adhesion-modifying additive is preferably added to the polymeric material of the skin layer as a masterbatch. The masterbatch preferably comprises from 1% to 50% by weight of the adhesion-modifying additive, more preferably from 2% to 30% by weight.

In general, the use of processing aids, including metal stearates, such as calcium stearate, has been found to be ineffective in reducing adhesion and should be avoided.

While the invention has been found to be particularly applicable to combinations of adherent polymeric materials and adhesion-reducing additives, in principle it could also be applied to non-adherent polymeric materials, whereupon the adhesion-modifying additive would need to be an adhesion-promoting additive.

An advantage of the plastics pipes of the present invention is that the normal UV stabiliser and colorant package need not be included in the plastics material of the inner core, provided that sufficient quantities of these materials are included in the skin layer. This enables the inner core to comprise a natural polymeric material, free or substantially free from additives which add to the cost of the core material and which, in certain circumstances, may impair the mechanical or physical properties of the core material. Alternatively, stabilisers can be included in the core material, but the outer protective skin layer can be coloured to indicate the underlying grade of pipe and/or the fluid being transported by the pipe.

Suitable stabiliser or ultra-violet blocking additives for the outer protective skin include, for example, titanium dioxide, carbon black, and other fillers. Whilst carbon black is an excellent UV stabiliser and reinforcing filler, buried pipes are frequently colour coded and its use in the outer protective layer is therefore not possible for many applications. Titanium dioxide is, therefore, the preferred filler and UV stabiliser since this is also compatible with many colorant packages. Other filler materials, such as chalk and talc, may also be used. The preferred filler particle size is dependent on the filler

being used, but for titanium dioxide, for example, the average particle size range is preferable from 0.003 to 0.025 microns.

The skin layer and the inner core can, of course, each comprise more than one layer of polymeric material, although in practice this is not usually necessary.

The relative thickness of the skin layer and the dimensions of the pipe have also been found to affect the impact resistance of the pipe. This is discussed in GB 2297138. Preferably the skin layer has a thickness of greater than 0.1 mm, more preferably greater than 0.2 mm, and most preferably within the range of from about 0.3 mm to 2.0 mm.

The dimensions of the pipe and the protective layer are preferably such that the ratio of the external diameter of the pipe to the thickness of the skin layer is at least 70, more preferably at least 100, most preferably in the range 100 to 800. From this it can be seen that it is possible to use a thicker skin layer on a pipe of greater diameter.

When stripping the skin layer from the pipe, it is important that no residue or holidays should be left on the pipe surface that could interfere with the electrofusion jointing process. Thus conventional adhesives and skin layers that are prone to tearing or fragmentation should be avoided. In general the force required to rupture the skin layer should be greater than the force required to peel the skin layer from the inner core.

By "a clean surface" in this specification is meant a

pipe surface that can be subjected to electrofusion jointing without further preparation or treatment. Such surfaces should give rise to a quality of electrofusion joint that meets the requirements of one or more of pr EN12201 part 3, pr EN1555 part 3 and WIS 04-32-14.

The composite plastics pipe of the present invention is preferably produced by co-extrusion, wherein the polymeric materials are brought together in the pressure area of the die and exit as a single extrudate. For example, the die may be connected to one, two, or more extruders and fed with separate streams of molten material. Alternatively, the die may be provided with concentric die outlets fed with separate streams of molten polymeric materials which are to form the inner core and the skin layer. In this case, the extrudates, on leaving the extruder die outlets, can be brought into contact with each other whilst still molten, preferably in a sizing die which simultaneously adjusts the outer diameter of the pipe.

In a further alternative, the inner core extrudate may be passed through a sizing die before applying the skin layer. In this case it may be necessary to re-heat or flame-brush the surface of the inner core extrudate to create a surface ready to receive the skin layer. Because of the difficulty of maintaining a consistent adhesion between the inner core and the skin layer, and of keeping the core surface clean (prior to coating with the skin), this method is not presently preferred.

The method of the invention is illustrated by the following Examples:

EXAMPLE 1

A polyethylene core pipe of nominal outer diameter 90mm was co-extruded with a propylene random copolymer skin layer. The experiment was repeated replacing the propylene random copolymer with (I) a propylene block copolymer and (II) with a blend of the copolymers, in each case with the addition of 15% by weight of a masterbatch comprising 20% by weight of a glycerol ester.

Skin adhesion was measured using a rolling drum peel test as described in Appendix 1.

The skin layers of all of the resultant pipes could be peeled readily using a simple hand tool, exposing a clean surface of the core pipe. Electrofusion jointing tests gave very good results in conformance with prEN12201 part 3, prEN1555 part 3 and WIS 04-32-14. In a comparison test, a pipe was extruded with a propylene block copolymer skin layer without the glycerol ester. The skin layer firmly adhered to the core pipe and could not be removed from the pipe by peeling.

The impact strength of the pipes was measured at -10°C , with and without the skin layer, using the method of EN 1411:1996. In further experiments the pipes were notched at 90° to the point of impact prior to testing to simulate service conditions. The results are given in Table 1.

TABLE 1

PIPE			
Ø(MM) -SDR	90-17	90-17	90-17
Core resin	Polyethylene	Polyethylene	Polyethylene
SKIN			
Propylene random	100%	60%	-

copolymer			
Propylene block copolymer	-	25%	85%
Masterbatch	-	15% glycerol ester	15% glycerol ester
Thickness (mm)	0.5-1.0	0.79	0.67
SKIN ADHESION			
Min (N/mm)	0.3	0.79	1.08
Mean (N/mm)	-	1.38	1.55
Max (N/mm)	0.8	1.88	1.96
IMPACT at - 10°C			
Un-Notched (J)	103-324	<400	>588
No skin, un- notched (J)	487-588		
Notched to 0.2mm depth (J)	103	188*	333*
No Skin, notched to 0.2mm depth (J)	387		

*Passed if the skin breaks but the core remains intact.

The results show that by using an adhesion-reducing additive to reduce the bond strength of a propylene block copolymer skin layer to a polyethylene core, the impact strength of the pipe can be substantially increased when compared to a similar pipe having a propylene random copolymer skin layer, whilst the peelability of the pipe is retained.

EXAMPLE 2

The procedure of Example 1 was repeated, by extruding a polyethylene inner core and a polypropylene skin layer including a range of adhesion-reducing additives. All percentages are by weight. The same tests were carried out with the following results:

Description			Dimensions			Peel Resistance			External Impact		
Dev	Materials	Core	OD	SDR	Skin	Mean	Max	Specific	Test Temp	Energy @HS0	
Ref		Skin %	Nominal mm	mm	Mean mm	N/mm	N/mm		°C	Joules	
1	P100 Polyethylene	PP 97.5 GMS 2.5	90	17	0.785	2.58	3.08	notched	-10.00	558.97	
						2.66	3.24				
2	P100 Polyethylene	PP 97 GMS 3	90	17	0.78	2.26	2.82	notched	-10.00	397.16	
						2.49	2.87				
3	P100 Polyethylene	PP 96.5 GMS 3.5	90	17	0.77	2.14	2.57	notched	-10.00	523.67	
						2.22	2.63				
4	P100 Polyethylene	PP 96 GMS 4	90	17	0.6975	2.27	2.58	notched	-10.00	533.96	
						2.10	2.57				
5	P100 Polyethylene	PP 97.5 GMS 2.5	90	17	0.795	1.66	2.03	notched	-10.00	578.09	
						1.66	2.00				
6	P100 Polyethylene	PP 97 GMS 3	90	17	0.785	1.24	1.71	notched	-10.00	465.56	
						1.50	1.77				
7	P100 Polyethylene	PP 96.5 GMS 3.5	90	17	0.7425	1.74	2.11	notched	-10.00	520.73	
						1.93	2.22				
8	P100 Polyethylene	PP 96 GMS 4	90	17	0.71	2.35	2.71	notched	-10.00	562.65	
						2.15	2.53				
9	P100 Polyethylene	PP 99 ERUCAMIDE 1	90	17	0.7475	1.82	2.23	notched	-10.00	558.97	
						1.87	2.72				
10	P100 Polyethylene	PP 97 ERUCAMIDE 3	90	17	0.67	1.61	1.94	notched	-10.00	542.05	
						1.69	2.16				
11	P100 Polyethylene	PP 99 STEARAMIDE 1	90	17	0.615	1.37	1.72	notched	-10.00	558.97	
						1.58	2.00				
12	P100 Polyethylene	PP 97 STEARAMIDE 3	90	17	0.7225	1.64	1.93	notched	-10.00	572.94	
						1.67	1.94				
13	P100 Polyethylene	PP 99 EBS 1	90	17	0.625	1.37	1.65	notched	-10.00	571.47	
						1.34	1.68				
14	P100 Polyethylene	PP 97 EBS 3	90	17	0.595	1.10	1.38	notched	-10.00	566.33	
						1.17	1.40				

EBS = Ethylene-Bis-Stearamide
 PP = Polypropylene block copolymer
 GMS = Glycerol Mono-Stearate

These results further demonstrate the improvement in impact strength and peelability obtained using the method of the present invention.

APPENDIX 1**DETERMINATION OF THE ADHESION STRENGTH OF PIPE SKIN - CORE PEEL****Apparatus**

A tensile testing machine accurate to grade A of BS5214 : Part 1: 1975 or grade 1 of BS1610 : Part 1 : 1985, for example, a Lloyds tensile test machine, using a 100N load cell.

Test Specimens

Two test pieces are cut one from each end of the sample pipe, 25mm +/- 2mm wide, the two sample rings of pipe are trimmed around the circumference to remove the jagged edge. The pipe is marked along top dead centre (TDC) of the extrusion line (if known).

The two ring specimens are marked with an indelible marker at quarterly points around the circumference beginning at TDC (if known) as illustrated in figure 1.

Procedure

Cut through the skin along mark at TDC & prise edge of skin from pipe, peel skin off to 30 - 40mm length, feed peeled skin through the jig as shown & clamp in upper jaws.

Mount the test piece in the jig as shown in Figure 2 and 2a.

The skin is then peeled from the pipe at a separation rate of 100mm/min and a trace recorded of load versus time.

The average value of the load required to peel the skin sample is calculated (Newtons), and divided by the true width of the peel sample to obtain the test result (Newtons/millimetre).

The average of the 10 peak load values recorded is calculated (Newtons), and divided by the true width of the peel sample to obtain the test result (Newtons/millimetre).

The reader's attention is directed to all papers and documents which are filed concurrently with or previous to this specification in connection with this application and which are open to public inspection with this specification, and the contents of all such papers and documents are incorporated herein by reference.

All of the features disclosed in this specification (including any accompanying claims, abstract and drawings), and/or all of the steps of any method or process so disclosed, may be combined in any combination, except combinations where at least some of such features and/or steps are mutually exclusive.

Each feature disclosed in this specification (including any accompanying claims, abstract and drawings), may be replaced by alternative features serving the same, equivalent, or similar purpose, unless expressly stated otherwise. Thus, unless expressly stated otherwise, each feature disclosed is one example only of a generic series of equivalent or similar features.

The invention is not restricted to the details of any foregoing embodiments. The invention extends to any novel one, or any novel combination, of the features disclosed in this specification (including any accompanying claims, abstract and drawings), or to any novel one, or any novel combination, of the steps of any method or process so disclosed.

CLAIMS

1. A plastics pipe which comprises an inner core and an outer removable skin layer bonded thereto,

the outer removable skin layer comprising a polymeric material, chosen for its physical and mechanical properties, and an adhesion-modifying additive,

the adhesion-modifying additive being present in the skin layer in an amount such that the adhesion of the skin layer to the inner core is sufficient to prevent substantial undesired relative movement between the skin layer and the core during installation, but insufficient to prevent the outer skin layer from being cleanly removed by peeling, at least at the ends of the pipe, and insufficient to cause a substantial reduction in the impact strength of the inner core.

2. A plastics pipe according to claim 1, wherein the strength of the adhesive bond between the skin layer and the inner core is from 0.2 N/mm to 2.0 N/mm, when measured by a rolling drum peel test as described in Appendix 1.

3. A plastics pipe according to claim 1 or 2, wherein the strength of the adhesive bond between the skin layer and the inner core is from 0.3 N/mm to 1.5 N/mm, when measured by a rolling drum peel test as described in Appendix 1.

4. A plastics pipe according to any one of the preceding claims, in which the strength of the adhesive bond between the skin layer and the inner core is such that the impact strength of the

composite pipe is at least 50%, preferably 75%, of the impact strength of the inner core without the skin layer.

5. A plastics pipe according to any one of the preceding claims, in which the inner core comprises polyethylene.
6. A plastics pipe according to any one of the preceding claims, wherein the skin layer comprises a propylene homo-or co-polymer, a propylene block co-polymer, or a propylene random copolymer.
7. A plastics pipe according to claim 6, wherein the skin layer comprises a propylene block co-polymer.
8. A plastics pipe according to any one of the preceding claims, in which the inner core comprises polyethylene and the skin layer comprises a propylene co-polymer and wherein the impact strength of the pipe is greater than 300 joules, when measured using the method of EN1411:1996 at a temperature of -10°C using a 90mm tup for impacting the pipe.
9. A plastics pipe according to any one of the preceding claims, wherein the skin layer comprises an adherent polymeric material and an appropriate amount of an adhesion-reducing additive.
10. A plastics pipe according to claim 9, wherein the adhesion-reducing additive in the skin layer is present in an amount of from 0.5% to 10% by weight.

11. A plastics pipe according to claim 9 or 10, wherein the adhesion reducing additive is an ester of a polyhydric alcohol.
12. A plastics pipe according to claim 11, wherein the polyhydric alcohol is glycerol.
13. A plastics pipe according to claim 11 or 12, wherein the ester is a fatty acid ester.
14. A plastics pipe according to claim 11 or 12, wherein the adhesion-reducing additive is glycerol mono-stearate.
15. A plastics pipe according to any one of the preceding claims, which comprises an inner core of polyethylene and a skin layer of a propylene block copolymer comprising from 2% to 4% of a glycerol ester.
16. A plastics pipe according to any one of claims 1 to 10, wherein the adhesion-reducing additive is a fatty acid amide.
17. A plastics pipe according to claim 16, wherein the fatty acid amide is stearamide or erucamide.
18. A plastics pipe according to claim 16, wherein the fatty acid amide is ethylene-bis-stearamide.
19. A plastics pipe according to any one of the preceding claims, wherein the skin layer has a thickness within the range of from 0.2 mm to 2.0 mm.

20. A plastics pipe according to any one of the preceding claims, wherein the ratio of the external diameter of the pipe to the thickness of the skin layer is from 100 to 800.
21. A plastics pipe according to any one of the preceding claims, wherein the strength (in N per mm of width) of the skin layer exceeds the peel strength (in N per mm width) of the adhesive bond between the outer removable skin layer and the inner core.
22. A plastics pipe substantially as hereinbefore described.
23. A method for the production of a plastics pipe comprising an inner core and an outer removable skin layer bonded thereto, the outer removable skin layer comprising a polymeric material chosen for its physical and mechanical properties, and an effective amount of an adhesion-modifying additive, which method comprises co-extruding molten polymeric materials forming the inner core and the outer removable skin layer from one or more extruder dies, bringing the molten polymeric materials together and allowing them to cool, such that, on cooling, the adhesion of the skin layer to the inner core is sufficient to prevent substantial undesired relative movement between the skin layer and the core during installation of the pipe, but insufficient to prevent the skin layer from being cleanly removed by peeling, at least at the ends of the pipe, and insufficient to cause a substantial reduction in the impact strength of the inner core.

24. A method according to claim 23, wherein the polymeric materials of the inner core and the outer removable skin layer are extruded simultaneously and brought together whilst still molten.
25. A method according to claim 23 or 24, substantially as described in the Examples.
26. A method of making a joint to a plastics pipe according to any one of claims 1 to 22, or of joining two such plastics pipes, which comprises peeling the skin layer from the region or regions of the pipe to be joined, to expose a clean surface suitable for electrofusion jointing, installing an electrofusion fitting over the clean surface or surfaces of the pipe or pipes and activating the electrofusion fitting to fuse the region or regions of the pipe or pipes thereto.

Figure 1

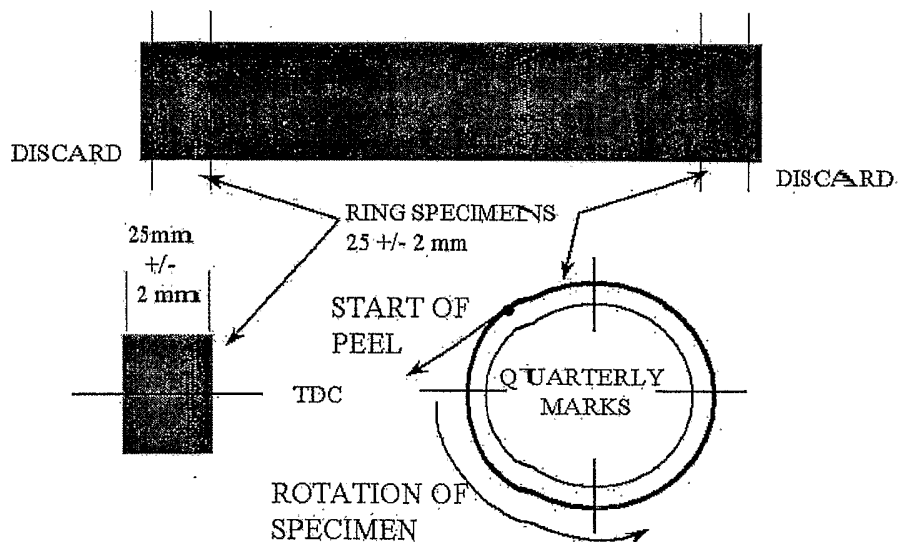
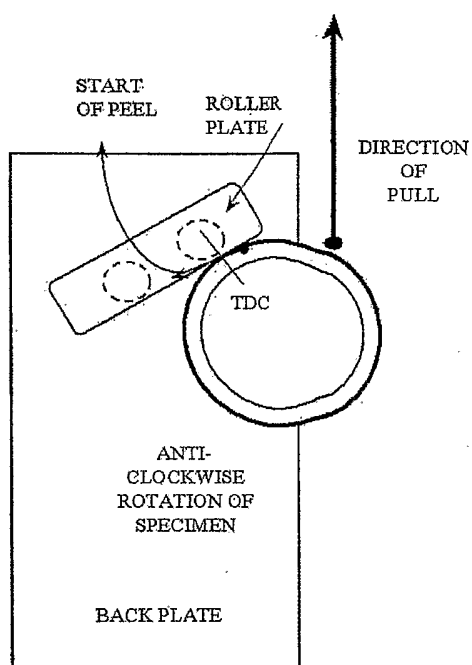

Figure 2a

Figure 2



INTERNATIONAL SEARCH REPORT

International	Application No
PCT/GB	03/03613

A. CLASSIFICATION OF SUBJECT MATTER

IPC 7 B32B1/08 B32B27/32 F16L9/12 C08L23/10 C08L23/00
C08K5/00

According to International Patent Classification (IPC) or to both national classification and IPC

B. FIELDS SEARCHED

Minimum documentation searched (classification system followed by classification symbols)

IPC 7 B32B F16L C08L C08K

Documentation searched other than minimum documentation to the extent that such documents are included in the fields searched

Electronic data base consulted during the international search (name of data base and, where practical, search terms used)

EPO-Internal, PAJ, WPI Data

C. DOCUMENTS CONSIDERED TO BE RELEVANT

Category*	Citation of document, with indication, where appropriate, of the relevant passages	Relevant to claim No.
X	EP 0 604 907 A (UPONOR NV) 6 July 1994 (1994-07-06) cited in the application column 4, line 21 - line 39; claims 2,12,26,29-32 column 2, line 23 - line 30; figures ---	1,5,9, 23,24,26
A	GB 2 323 556 A (UPONOR LTD) 30 September 1998 (1998-09-30) cited in the application page 5, line 26 -page 8, last line page 9, line 15 -page 12, line 3 page 12, line 18 -page 16, line 11; claims --- -/--	1-8, 19-21, 23,24,26

Further documents are listed in the continuation of box C.

Patent family members are listed in annex.

* Special categories of cited documents :

- *A* document defining the general state of the art which is not considered to be of particular relevance
- *E* earlier document but published on or after the international filing date
- *L* document which may throw doubts on priority claim(s) or which is cited to establish the publication date of another citation or other special reason (as specified)
- *O* document referring to an oral disclosure, use, exhibition or other means
- *P* document published prior to the international filing date but later than the priority date claimed

- *T* later document published after the international filing date or priority date and not in conflict with the application but cited to understand the principle or theory underlying the invention
- *X* document of particular relevance; the claimed invention cannot be considered novel or cannot be considered to involve an inventive step when the document is taken alone
- *Y* document of particular relevance; the claimed invention cannot be considered to involve an inventive step when the document is combined with one or more other such documents, such combination being obvious to a person skilled in the art.
- *Z* document member of the same patent family

Date of the actual completion of the international search

1 December 2003

Date of mailing of the international search report

05/12/2003

Name and mailing address of the ISA

European Patent Office, P.B. 5818 Patentlaan 2
NL - 2280 HV Rijswijk
Tel. (+31-70) 340-2040, Tx. 31 651 epo nl,
Fax: (+31-70) 340-3016

Authorized officer

Kanetakis, I

INTERNATIONAL SEARCH REPORT

Internati

pplication No

PCT/GB 03/03613

C.(Continuation) DOCUMENTS CONSIDERED TO BE RELEVANT

Category °	Citation of document, with indication, where appropriate, of the relevant passages	Relevant to claim No.
X	GB 2 300 456 A (VICTAULIC PLC) 6 November 1996 (1996-11-06) cited in the application page 6, last paragraph -page 7, paragraph 3; claim 7 page 12, last paragraph -----	1,5,6
X	WO 93 00212 A (UPONOR NV) 7 January 1993 (1993-01-07) cited in the application page 4, line 15 - line 24; claims -----	1
A	GB 2 297 137 A (UPONOR LTD) 24 July 1996 (1996-07-24) cited in the application page 5, line 16 - line 24; claims -----	1,23,26
A	GB 2 297 138 A (UPONOR LTD) 24 July 1996 (1996-07-24) cited in the application page 6, line 1 - line 15; claims -----	1,23,26

INTERNATIONAL SEARCH REPORT

Information on patent family members

Internatic	pplication No
PCT/GB 03/03613	

Patent document cited in search report	A	Publication date	Patent family member(s)	Publication date			
EP 0604907	A	06-07-1994	FI 925897 A	29-06-1994			
			AT 166609 T	15-06-1998			
			AU 670835 B2	01-08-1996			
			AU 5269093 A	07-07-1994			
			CA 2112440 A1	29-06-1994			
			DE 69318813 D1	02-07-1998			
			DE 69318813 T2	24-09-1998			
			DK 604907 T3	22-03-1999			
			EP 0604907 A1	06-07-1994			
			ES 2117089 T3	01-08-1998			
			JP 7001542 A	06-01-1995			
			US 5759461 A	02-06-1998			
			<hr/>				
			GB 2323556	A	30-09-1998	GB 2297137 A	24-07-1996
AT 244844 T	15-07-2003						
AU 705621 B2	27-05-1999						
AU 4537896 A	07-08-1996						
CZ 9702268 A3	16-09-1998						
DE 69629013 D1	14-08-2003						
DE 804699 T1	25-10-2001						
DK 804699 T3	27-10-2003						
WO 9622485 A1	25-07-1996						
EP 1321703 A2	25-06-2003						
EP 0804699 A1	05-11-1997						
FI 973028 A	08-09-1997						
GB 2297138 A ,B	24-07-1996						
HU 9702402 A2	30-03-1998						
JP 10512656 T	02-12-1998						
NO 973309 A	16-09-1997						
PL 321369 A1	08-12-1997						
RU 2165047 C2	10-04-2001						
TR 9700661 T1	21-01-1998						
US 6016849 A	25-01-2000						
<hr/>							
GB 2300456	A	06-11-1996	NONE				
<hr/>							
WO 9300212	A	07-01-1993	FI 99158 B	30-06-1997			
			AU 2019292 A	25-01-1993			
			DE 4291982 T0	13-01-1994			
			WO 9300212 A1	07-01-1993			
			GB 2263524 A ,B	28-07-1993			
<hr/>							
GB 2297137	A	24-07-1996	AT 244844 T	15-07-2003			
			AU 705621 B2	27-05-1999			
			AU 4537896 A	07-08-1996			
			CZ 9702268 A3	16-09-1998			
			DE 69629013 D1	14-08-2003			
			DE 804699 T1	25-10-2001			
			DK 804699 T3	27-10-2003			
			WO 9622485 A1	25-07-1996			
			EP 1321703 A2	25-06-2003			
			EP 0804699 A1	05-11-1997			
			FI 973028 A	08-09-1997			
			GB 2297138 A ,B	24-07-1996			
			GB 2323556 A ,B	30-09-1998			
			HU 9702402 A2	30-03-1998			
			JP 10512656 T	02-12-1998			
			NO 973309 A	16-09-1997			

INTERNATIONAL SEARCH REPORT

Information on patent family members

Internatic	Application No
PCT/GB 03/03613	

Patent document cited in search report	Publication date	Patent family member(s)	Publication date
GB 2297137	A	PL 321369 A1	08-12-1997
		RU 2165047 C2	10-04-2001
		TR 9700661 T1	21-01-1998
		US 6016849 A	25-01-2000
GB 2297138	A	24-07-1996	
		GB 2297137 A	24-07-1996
		AT 244844 T	15-07-2003
		AU 705621 B2	27-05-1999
		AU 4537896 A	07-08-1996
		CZ 9702268 A3	16-09-1998
		DE 69629013 D1	14-08-2003
		DE 804699 T1	25-10-2001
		DK 804699 T3	27-10-2003
		WO 9622485 A1	25-07-1996
		EP 1321703 A2	25-06-2003
		EP 0804699 A1	05-11-1997
		FI 973028 A	08-09-1997
		GB 2323556 A , B	30-09-1998
		HU 9702402 A2	30-03-1998
		JP 10512656 T	02-12-1998
		NO 973309 A	16-09-1997
PL 321369 A1	08-12-1997		
RU 2165047 C2	10-04-2001		
TR 9700661 T1	21-01-1998		
US 6016849 A	25-01-2000		