



- (51) **International Patent Classification:**
B64C 29/00 (2006.01)
- (21) **International Application Number:**
PCT/IL2010/000416
- (22) **International Filing Date:**
26 May 2010 (26.05.2010)
- (25) **Filing Language:** English
- (26) **Publication Language:** English
- (30) **Priority Data:**
199009 27 May 2009 (27.05.2009) IL
- (71) **Applicant (for all designated States except US):** ISRAEL AEROSPACE INDUSTRIES LTD. [IL/IL]; Ben Gurion International Airport, 70100 Lod (IL).
- (72) **Inventors; and**
- (75) **Inventors/Applicants (for US only):** WOLFF, Amit [IL/IL]; 1/2 Hateena Street, 48210 Zur Moshe (IL). DEKEL, Guy [IL/IL]; 3 Shdema Street, 37861 Kazir (IL). ZIVAN, Lior [IL/IL]; 4 Nizanim Street, 38281 Hadera (IL).
- (74) **Agent:** REINHOLD COHN & PARTNERS; P.O.B. 13239, 61131 Tel-Aviv (IL).
- (81) **Designated States (unless otherwise indicated, for every kind of national protection available):** AE, AG, AL, AM,

AO, AT, AU, AZ, BA, BB, BG, BH, BR, BW, BY, BZ, CA, CH, CL, CN, CO, CR, CU, CZ, DE, DK, DM, DO, DZ, EC, EE, EG, ES, FI, GB, GD, GE, GH, GM, GT, HN, HR, HU, ID, IL, IN, IS, JP, KE, KG, KM, KN, KP, KR, KZ, LA, LC, LK, LR, LS, LT, LU, LY, MA, MD, ME, MG, MK, MN, MW, MX, MY, MZ, NA, NG, NI, NO, NZ, OM, PE, PG, PH, PL, PT, RO, RS, RU, SC, SD, SE, SG, SK, SL, SM, ST, SV, SY, TH, TJ, TM, TN, TR, TT, TZ, UA, UG, US, UZ, VC, VN, ZA, ZM, ZW.

(84) **Designated States (unless otherwise indicated, for every kind of regional protection available):** ARIPO (BW, GH, GM, KE, LR, LS, MW, MZ, NA, SD, SL, SZ, TZ, UG, ZM, ZW), Eurasian (AM, AZ, BY, KG, KZ, MD, RU, TJ, TM), European (AL, AT, BE, BG, CH, CY, CZ, DE, DK, EE, ES, FI, FR, GB, GR, HR, HU, IE, IS, IT, LT, LU, LV, MC, MK, MT, NL, NO, PL, PT, RO, SE, SI, SK, SM, TR), OAPI (BF, BJ, CF, CG, CI, CM, GA, GN, GQ, GW, ML, MR, NE, SN, TD, TG).

Declarations under Rule 4.17:

— of inventorship (Rule 4.17(iv))

Published:

— without international search report and to be republished upon receipt of that report (Rule 48.2(g))

(54) **Title:** AIR VEHICLE

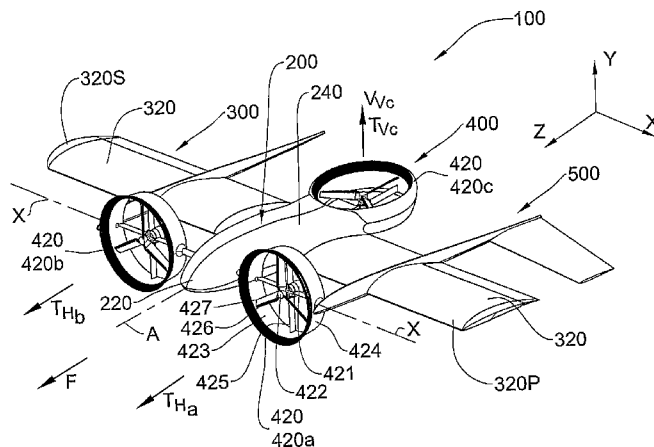

FIG. 1

(57) **Abstract:** According to one aspect of the invention there is provided a system and method for providing propulsion and control to an air vehicle, and for operating the vehicle, in which at least three propulsion units provide vertical thrust for vectored thrust flight, and in which at least one or two of the propulsion units also provide thrust for vectored thrust cruising or aerodynamic flight by suitably tilting the respective propulsion units for changing the thrust vector thereof. At the same time, the three or more propulsion units are operated to generate controlling moments to the air vehicle about three orthogonal axes, pitch, roll and yaw, during vectored thrust flight (hover, cruising, etc.) or during aerodynamic flight for controlling the vehicle. The control moments are generated by selectively varying the thrust generated by each of the propulsion units independently of one another, and: by selectively vectoring the thrust of one propulsion unit with respect to each of two independent tilt axes independently of one another, or by selectively vectoring the thrust of each of two propulsion units with respect to a respective tilt axis, independently of one another.



- 1 -

AIR VEHICLE

FIELD OF THE INVENTION

This invention relates to air vehicles, in particular to vertical take off and landing (VTOL) air vehicles, short take off and landing (STOL) air vehicles, and vertical/short take off and landing (V/STOL) air vehicles.

5 BACKGROUND OF THE INVENTION

There are at least four main categories of VTOL or V/STOL vehicles: where the vehicle has a single powerplant adapted for producing vertical as well as horizontal thrust; where the vehicle has separate powerplants for producing vertical and horizontal thrust; where the vehicle has a powerplant for vertical and horizontal thrust, plus a
10 supplemental powerplant for vertical thrust; other configurations.

By way of general background, the following publications disclose various aircraft configurations.

US 7,267,300 discloses an aircraft comprising an airframe, a power plant mounted on the airframe, and at least two propellers rotatably mounted on the airframe
15 and powered by the power plant for moving the aircraft in a generally forward direction during operation of the propellers. Also, the aircraft includes at least two counter-rotatable fan sets mounted on the airframe and powered by the power plant for providing upward lift to the aircraft during operation of the fan sets.

US 2006/0226281 discloses a vertical take-off and landing vehicle comprised of
20 a fuselage having a front, a rear, and two lateral sides and a set of four thrusters set to the front, the left, the right, and the rear of said fuselage. The thrusters are comprised of a set of two counter rotating propellers both of which creates lift. The two counter rotating propellers cancel out the torque effect normally created by using only one propeller. The ducted fan units are movable between a first position in which they
25 provide vertical lift and a second position in which they provide horizontal thrust using a set of servos and gears.

US 7,472,863 discloses a vertical takeoff and landing (VTOL) aircraft design comprising one internal combustion engine able to spit shaft power to four fan units. The fan units further employ counter rotating fan blades for stability. Separate

- 2 -

horizontal and vertical tilting mechanisms delivered to the fan units are additionally disclosed. A variation in design is further included wherein electric motors provide the necessary shaft power.

US 2004/094662 discloses an Unusual Flying Object said to have VTOL
5 capabilities including forward flight with a Linear Induction Magnetic Bearings power drive.

US 7,461,811 discloses a STOL or VTOL winged aircraft comprising a fuselage and a fixed wing attached to the fuselage and extending outward from the two lateral sides thereof, forming one wing component extending outward from one side of the
10 fuselage and a second wing component extending outward from the opposite side of the fuselage. At least one "thruster" is disposed in each wing component to provide vertical lift to the aircraft when the aircraft is stationary or moving forward only slowly. The thruster includes a shaft mounted for rotation in the respective wing component and extending substantially parallel to the wing axis and a plurality of fan blades attached to
15 the shaft for movement of air.

US 2003/062442 discloses a personal aircraft said to be capable of vertical take-off and landing and comprises a passenger compartment having a front, a rear and two sides, and a plurality of independently powered thrusters attached to the outer periphery of the compartment. At least three thrusters are disposed on each side of the
20 compartment. The thrusters, which are preferably ducted fan units, are capable of providing a vertically upward force to the compartment.

US 6,892,979 discloses a personal aircraft said to be capable of vertical take-off and landing which comprises: (a) a fuselage having a front end, a rear end and two lateral sides, the fuselage having a central longitudinal axis extending from the front end
25 to the rear end, between the two lateral sides; (b) at least one, and preferably two or more, ducted fans, each arranged in the fuselage between the front end and the rear end and between the two lateral sides, for providing vertical lift; and (c) at least one substantially horizontal wing attached to each side of the fuselage and extending outward with respect to the central longitudinal axis.

US 6,464,166 discloses a vehicle, particularly a VTOL air vehicle, including a
30 duct carried by the vehicle frame with the longitudinal axis of the duct perpendicular to the longitudinal axis of the vehicle frame; a propeller rotatably mounted within the duct about the longitudinal axis of the duct to force an ambient fluid, e.g. air, therethrough

- 3 -

from its inlet at the upper end of the duct through its exit at the lower end of the duct, and thereby to produce an upward lift force applied to the vehicle; and a plurality of parallel, spaced vanes pivotally mounted to and across the inlet end of the duct about pivotal axes perpendicular to the longitudinal axis of the duct and substantially parallel
5 to the longitudinal axis of the vehicle frame. The vanes are selectively pivotal to produce a desired horizontal force component to the lift force applied to the vehicle. Various vane arrangements are disclosed for producing side, roll, pitch and yaw movements of the vehicle.

US 2003/080242 discloses an aircraft that is mounted with turbofan engines with
10 separate core engines having fan engines used commonly for cruising and lifting up, through enabling to direct the thrust from fan engines to all directions by supporting the fan engines composing the turbofan engines with separate core engines in biaxial support so that the fan engines are rotatable in the direction of pitching and rolling, the fan engines are mounted on both sides of each of front and rear wings.

15 US 2007/0057113 discloses a system and method are provided for a STOL/VTOL aircraft that stores required take-off power in the form of primarily an electric fan engine, and secondarily in the form of an internal combustion engine.

US 2008/0054121 discloses a VTOL vehicle comprising a fuselage having forward and aft propulsion units, each propulsion unit comprising a propeller located
20 within an open-ended duct wall wherein a forward facing portion of the duct wall of at least the forward propulsion unit is comprised of at least one curved forward barrier mounted for horizontal sliding movement to open the forward facing portion to thereby permit air to flow into the forward facing portion when the VTOL vehicle is in forward flight.

25 US 2002/113165 discloses a vertical takeoff aircraft that uses ducted fans for lift and propulsion. The fans are attached to an airframe and are disposed on opposite lateral sides of the aircraft. The thrust from the each of the fans may be deflected in different directions by using vanes with flaps disposed within the ducts of the fans, as well as by tilting the entire fan assemblies.

30 US 6,488,232 discloses a single passenger aircraft configured to vertically take-off and land. An airframe is configured to support the passenger in an upright position during take-off and landing and during flight. The aircraft includes a pair of propulsion devices that are mounted on an airframe above the level of the pilot. A set of hand

- 4 -

operated control devices are mechanically linked to the propulsion devices for varying the orientation of the propulsion devices during flight.

SUMMARY OF THE INVENTION

5 According to a first aspect of the invention there is provided a system and method for providing propulsion and control to an air vehicle, and for operating the vehicle, in which at least three propulsion units provide vertical thrust for vectored thrust flight, and wherein at least one or two of the propulsion units also provide thrust for vectored thrust cruising or aerodynamic flight by suitably tilting the propulsion units
10 for changing the thrust vector thereof. At the same time, the at least three propulsion units are operated to generate controlling moments to the air vehicle about three orthogonal axes, pitch, roll and yaw, during vectored thrust flight (hover, cruising, etc.) or during aerodynamic flight for controlling the vehicle (though for cruising vectored thrust flight and aerodynamic flight only two of the at least three propulsion units can be
15 operated to generate the aforesaid controlling moments to the air vehicle about the three orthogonal axes, pitch, roll and yaw). The control moments are generated by selectively varying the thrust generated by each of the propulsion units independently of one another, and: by selectively vectoring the thrust of one propulsion unit with respect to each of two independent tilt axes independently of one another, or by selectively
20 vectoring the thrust of each of two propulsion units with respect to a respective tilt axis, independently of one another.

Although more than three propulsion units may be provided and/or each propulsion unit may be configured for being tilted about one or two independent axes, the first aspect of the invention also provides for at least some embodiments of the
25 propulsion system to be configured in a relatively simple manner, comprising three propulsion units, in which two thrust vectors are independently and selectively variable via tilting of one or two of the propulsion units, and the three thrusts are independently controllable, to provide control moments in three degrees of freedom, plus thrust for hover and cruise.

30

According to a first embodiment, there is provided a propulsion and control system for an air vehicle comprising at least three propulsion units:

- 5 -

wherein at least a first and a second said propulsion units are tiltable propulsion units, each said tiltable propulsion unit being configured for generating a respective thrust and for being selectively tiltable about at least one respective tilt axis to provide a respective thrust vector that is selectively variable at least between a
5 general vertical thrust vector direction and a general longitudinal thrust vector direction with respect to the air vehicle; and

wherein at least a third said propulsion unit is configured for generating a respective thrust having a thrust vector alignable in at least said general vertical thrust vector direction;

10 wherein said system is configured for selectively enabling said propulsion units to provide sufficient thrust to the air vehicle for vectored thrust flight when said respective thrust vectors are aligned with said generally vertical thrust vector direction, and for selectively enabling said propulsion units to provide sufficient thrust to the air vehicle for aerodynamic flight when said respective variable thrust
15 vectors are aligned with said generally longitudinal thrust vector direction, and

wherein said system is further configured for selectively generating variable control moments for control and stability of the air vehicle including:

- (a) controllably varying said respective thrust generated by each said propulsion unit independently of one another; and
- 20 (b) controllably varying said respective variable thrust vector provided by each said tiltable propulsion unit independently of one another.

Each said tiltable propulsion unit may comprise, for example, any one of a tiltable ducted fan unit, a tiltable propeller unit, a tiltable turbojet unit, a tiltable turbofan unit, a tiltable propfan unit, and so on. Each such tiltable ducted fan unit may comprise
25 at least one fan, and additionally or alternatively has an absence of vanes for controlling the respective said variable thrust vector. Each said tiltable propulsion unit provides a desired thrust vector by tilting of the respective tiltable propulsion unit about a corresponding tilt axis.

The third propulsion unit may be a non-tiltable propulsion unit, fixedly (i.e.,
30 non-tiltably) mountable to the air vehicle to provide a thrust having a fixed thrust vector with respect thereto. Such a non-tiltable propulsion unit may comprise any one of non-tiltable ducted fan unit, a non-tiltable propeller unit, a non-tiltable turbojet unit, a non-tiltable turbofan unit, a non-tiltable propfan unit. For example, such a non-tiltable

- 6 -

ducted fan unit may comprise at least one fan and additionally or alternatively may have an absence of movable vanes for controlling the respective said vector. Alternatively, the third propulsion unit may also be a tiltable propulsion unit, tiltable about at least one respective tilt axis. Such a third propulsion unit may be configured for providing a
5 respective variable thrust vector that is selectively variable at least between said general vertical thrust vector direction and said general longitudinal thrust vector direction, and may thus contribute to the thrust of the air vehicle for aerodynamic flight.

Additionally or alternatively, the system may be configured to provide said variable control moment in the form of a pitch control moment in said vectored thrust
10 flight by varying a ratio of said respective thrusts generated by said tiltable propulsion units with respect to said respective thrust generated by said third propulsion unit, to thereby generate a couple with respect to the pitch axis.

Additionally or alternatively, the system may be configured to provide said variable control moment in the form of a yaw control moment in said vectored thrust
15 flight by suitably varying said respective thrust vectors of said tiltable propulsion units (responsive to tilting said tiltable propulsion units) in mutually opposite directions with respect to the respective said tilt axes.

Additionally or alternatively, the system may be configured to provide said variable control moment in the form of a roll control moment in said vectored thrust
20 flight by varying a ratio of said respective thrust generated by said first propulsion unit with respect to said respective thrust generated by said second propulsion unit, to thereby generate a couple with respect to the roll axis.

Additionally or alternatively, the system may additionally be further configured to provide a generally longitudinal (forward or aft) motion when in said vectored thrust
25 flight by suitably varying said respective thrust vectors of said tiltable propulsion units (responsive to tilting said tiltable propulsion units) in mutually similar directions.

Additionally or alternatively, the system may be configured to provide said variable control moment in the form of a yaw control moment in said aerodynamic flight by varying a ratio of the thrust generated by said first propulsion unit with respect
30 to the thrust generated by said second propulsion unit, to thereby generate a couple with respect to the yaw axis.

Additionally or alternatively, the system may be configured to provide said variable control moment in the form of a roll control moment in said aerodynamic flight

- 7 -

by suitably by suitably varying said respective thrust vectors of said tiltable propulsion units (responsive to tilting said tiltable propulsion units) in mutually opposite directions with respect to the respective said tilt axes.

Additionally or alternatively, the system may be configured to provide said
5 variable control moment in the form of a pitch control moment in said aerodynamic flight by suitably varying said respective thrust vectors of said tiltable propulsion units (responsive to tilting said tiltable propulsion units) in mutually similar directions.

In at least this embodiment, each said tiltable propulsion unit may comprise a
10 respective motor that is tiltable with the rest of the respective propulsion unit, i.e., the motor is incorporated in the tiltable propulsion unit.

Each said tiltable propulsion unit may be configured for inducing a braking procedure for the respective motor while the respective tiltable propulsion unit is being tilted through a desired tilt angle to vary the respective thrust vector thereof.

In at least this embodiment, at least one said tiltable propulsion unit is a said
15 tiltable ducted fan unit, wherein said respective motor is accommodated in said respective tiltable ducted fan unit and configured for driving the respective said fan. In at least one embodiment, at least one said tiltable propulsion unit is a said tiltable propeller unit, wherein said respective motor is configured for driving a respective propeller thereof.

20 In at least some embodiments, said propulsion units are configured as mutually co-rotating propulsion units, i.e., the motors and/or the thrust producing vanes/propellers/propfans etc. are rotating in the same direction.

According to the first aspect of the invention there is also provided a method for
25 providing propulsion and control to an air vehicle, comprising,

(A) providing the air vehicle with at least three propulsion units, each propulsion unit being configured for providing a selectively adjustable thrust and having a thrust vector at least alignable in a general vertical thrust vector direction, and wherein at least two said propulsion units are each tiltable propulsion units and
30 further configured for enabling said respective thrust vector to be selectively variable at least between said general vertical thrust vector direction and a general longitudinal thrust vector direction with respect to the air vehicle; and

- 8 -

(B) selectively operating said propulsion units to provide sufficient thrust to the air vehicle for:

(i) vectored thrust flight, wherein said respective thrust vectors of said at least three propulsion units are aligned with said generally vertical thrust vector direction; and

5

(ii) aerodynamic flight, wherein said respective variable thrust vectors of said tiltable propulsion units are aligned with said generally longitudinal thrust vector direction;

(C) selectively generating variable control moments for control and stability of the air vehicle including:

10

(a) controllably varying said respective thrust generated by each one of said at least three said propulsion units independently of one another;

(b) controllably varying said respective variable thrust vector provided by each said tiltable propulsion unit independently of one another.

15

According to a second embodiment, there is provided a propulsion and control system for an air vehicle comprising at least three propulsion units:

wherein at least one said propulsion units is a tiltable propulsion unit, configured for generating a respective thrust and for being selectively tiltable about each one of at least two respective tilt axes to provide a first thrust vector that is selectively variable with respect to one said tilt axis at least between a general vertical thrust vector direction and a general longitudinal thrust vector direction, and to provide a second thrust vector that is selectively variable with respect to another said tilt axis; and

20

wherein at least two other said propulsion unit are each configured for generating a respective thrust having a respective thrust vector alignable in at least said general vertical thrust vector direction;

25

wherein said system is configured for selectively enabling said propulsion units to provide sufficient thrust to the air vehicle for vectored thrust flight when said respective thrust vectors are aligned with said generally vertical thrust vector direction, and for selectively enabling said at least one tiltable propulsion unit to provide sufficient thrust to the air vehicle for aerodynamic flight when said first thrust vector is aligned with said generally longitudinal thrust vector direction, and

30

- 9 -

wherein said system is further configured for selectively generating variable control moments for control and stability of the air vehicle including:

- (a) controllably and separately varying said respective thrust generated by each said propulsion unit independently of one another; and
- 5 (b) controllably and separately varying said first thrust vector provided by said tiltable propulsion unit independently of said second thrust vector.

The tiltable propulsion unit may be pivotably mounted to a one support ring or similar structure about the second tilt axis for enabling tilting about the second tilt axis, and the first support ring may in turn be pivotably mounted to a support structure (e.g.,
10 the air vehicle) about the first pivot axis, for enabling tilting about the first tilt axis. Thus, tilting about the first axis is independent of tilting about the second axis.

The first tilt axis may be generally orthogonal to the second tilt axis.

The tiltable propulsion unit may comprise, for example, any one of a tiltable ducted fan unit, a tiltable propeller unit, a tiltable turbojet unit, a tiltable turbofan unit, a
15 tiltable propfan unit. Such said tiltable ducted fan unit may comprise at least one fan, and additionally or alternatively has an absence of vanes for controlling the respective said variable thrust vector. The said tiltable propulsion unit provides a desired first thrust vector and/or a desired second thrust vector by tilting of the respective tiltable propulsion unit about the corresponding (first) tilt axis and/or the other corresponding
20 (second) tilt axis, respectively.

The said two other propulsion units may be non-tiltable propulsion units, fixedly (i.e., non-tiltably) mountable to the air vehicle to each provide a thrust having a fixed thrust vector with respect thereto. Such non-tiltable propulsion units may each comprise
25 any one of non-tiltable ducted fan unit, a non-tiltable propeller unit, a non-tiltable turbojet unit, a non-tiltable turbofan unit, a non-tiltable propfan unit. For example, each non-tiltable ducted fan unit may comprise at least one fan and additionally or alternatively may have an absence of vanes for controlling the respective said vector.

Alternatively, the said two other propulsion units may also each be a tiltable
30 propulsion unit, tiltable about at least one respective tilt axis, and may optionally also be configured for providing a respective variable thrust vector that is selectively variable at least between said general vertical thrust vector direction and said general longitudinal

- 10 -

thrust vector direction – thus also contributing to the total thrust for aerodynamic flight as well as for vectored thrust flight.

The system according to this embodiment may be configured to provide said variable control moment in the form of a pitch control moment in said vectored thrust flight by varying a ratio of said respective thrust generated by said tiltable propulsion unit with respect to said respective thrusts generated by said two other propulsion units to provide a couple about the pitch axis.

Additionally or alternatively, the system according to this embodiment may be configured to provide said variable control moment in the form of a yaw control moment in said vectored thrust flight by suitably varying said second thrust vector of said tiltable propulsion units with respect to second said tilt axis, i.e., by tilting the tilting propulsion unit about the second said tilt axis, which is aligned with the pitch axis.

Additionally or alternatively, the system according to this embodiment may be configured to provide said variable control moment in the form of a roll control moment in said vectored thrust flight by varying a ratio of said respective thrust generated by each of the said two other propulsion units to generate a couple about the roll axis.

Additionally or alternatively, the system according to this embodiment may additionally be further configured to provide a generally longitudinal (forward or aft) motion when in said vectored thrust flight by suitably varying said first thrust vector of said tiltable propulsion unit by tilting about the first tilt axis in a suitable direction. Alternatively, such forward or aft movement may be provided by first inducing a nose down or nose up pitch moment by varying the ratio of the moment or thrust between the aft and forward propulsion units, and in this orientation, the thrust has a horizontal component that propels the air vehicle forward or aft.

Additionally or alternatively, the system according to this embodiment may be configured to provide said variable control moment in the form of a yaw control moment in said aerodynamic flight by varying the said second thrust vector about said second tilt axis, which is aligned with the yaw axis when the tiltable propulsion unit is tilted to the aerodynamic flight position.

Additionally or alternatively, the system according to this embodiment may be configured to provide said variable control moment in the form of a roll control moment

- 11 -

in said aerodynamic flight by suitably by suitably independently varying said respective thrusts of said two other propulsion units to generate a couple about the roll axis.

Additionally or alternatively, the system according to this embodiment may be configured to provide said variable control moment in the form of a pitch control
5 moment in said aerodynamic flight by suitably varying said first thrust vector of said tiltable propulsion unit by tilting about said first tilt axis.

In at least this embodiment, said tiltable propulsion unit may comprise a respective motor that is tiltable with the rest of the respective propulsion unit, i.e., the motor is incorporated in the tiltable propulsion unit.

10 Said tiltable propulsion unit may optionally be configured for inducing a braking procedure for the respective motor while the respective tiltable propulsion unit is being tilted through a desired tilt angle to vary the respective thrust vector thereof.

In at least this embodiment, at least one said tiltable propulsion unit is a said tiltable ducted fan unit, wherein said respective motor is accommodated in said
15 respective tiltable ducted fan unit and configured for driving the respective said fan. In at least one embodiment, at least one said tiltable propulsion unit is a said tiltable propeller unit, wherein said respective motor is configured for driving a respective propeller thereof.

According to the first aspect of the invention there is also provided a method for
20 providing propulsion and control to an air vehicle, comprising,

(A) providing the air vehicle with at least three propulsion units, each propulsion unit being configured for providing a selectively adjustable thrust and having a thrust vector at least alignable in a general vertical thrust vector direction, and wherein at least one said propulsion units is a tiltable propulsion unit and wherein
25 said respective thrust vector is a first variable thrust vector configured to be selectively variable at least between said general vertical thrust vector direction and a general longitudinal thrust vector direction with respect to the air vehicle, and wherein said tiltable propulsion unit is further configured for providing a second thrust vector that is selectively variable; and

30 (B) selectively operating said propulsion units to provide sufficient thrust to the air vehicle for:

- 12 -

(i) vectored thrust flight, wherein said respective thrust vectors of said at least three propulsion units are aligned with said generally vertical thrust vector direction; and

(ii) aerodynamic flight, wherein said first variable thrust vector of said tiltable propulsion unit is aligned with said generally longitudinal thrust vector direction;

(C) selectively generating variable control moments for control and stability of the air vehicle including:

(a) controllably varying said respective thrust generated by each one of said at least three said propulsion units independently of one another;

(b) controllably varying said first variable thrust vector provided by said tiltable propulsion unit independently of second variable thrust vector.

According to the first aspect of the invention, there is also provided an air vehicle comprising the propulsion and control system according to the first aspect of the invention, for example according to the first or second embodiments thereof as disclosed above, said air vehicle comprising a center of gravity and a body. The air vehicle may be configured for cruising in aerodynamic flight, and the body may be in the form of a flying wing, or may be in the form of a fuselage with wings attached thereto in fixed-wing relationship, for example. Alternatively, the air vehicle is not configured for aerodynamic flight, but for cruising wherein lift is provided by vectored thrust.

In at least some embodiments, the body may be a fuselage and comprise wings and empennage, wherein said wings and empennage are configured for providing aerodynamic lift and stability of the air vehicle in said aerodynamic flight. At least one of said wings and said empennage may be further configured for generating variable aerodynamic control moments for control of the air vehicle in said aerodynamic flight.

Optionally, and according to another aspect of the invention, for these or other embodiments, the empennage may be configured for selectively changing the position of said center of gravity and/or the aerodynamic center. For example, the empennage may be mounted to said fuselage or said wings via a second support structure, said second support structure being configured for adjusting a longitudinal spacing between said empennage and said fuselage or said wings, respectively. For example, said second support structure may be configured for facilitating said adjusting, and may be optionally further configured for facilitating mounting and dismounting of said

- 13 -

empennage with respect to said fuselage or wings by a ground crew. Optionally, said second support structure may be configured for providing said adjusting in an automated manner.

According to another aspect of the invention, the said wings of these or other
5 embodiments may be modular and selectable from a group of modular wing sets, wherein each said modular wing set is configured for being mountable in turn to said body for providing aerodynamic lift in forward flight. For example, at least one said modular wing set may be configured for providing said air vehicle with a performance different from that provided by another said modular wing set. For example, each said
10 modular wing set is configured for facilitating mounting and dismounting of the respective modular wing set to said fuselage by a ground crew. According to this aspect of the invention, the air vehicle may also be operated in wingless mode by removing the wings.

Referring to the first embodiment of the propulsion and control system, the said
15 first and second propulsion units may be mounted to the air vehicle forward of said center of gravity of the air vehicle, and wherein said third propulsion unit is mounted aft of said center of gravity; alternatively, the opposite arrangement may be provided, with the third propulsion unit mounted forward, and the first and second propulsion units mounted aft of said center of gravity.

Referring to the second embodiment of the propulsion and control system, the
20 tiltable propulsion unit is mounted aft of said center of gravity, and the other two said propulsion units may be mounted to the air vehicle forward of said center of gravity of the air vehicle; alternatively, the opposite arrangement may be provided, with the tiltable propulsion unit mounted forward, and the other two propulsion units mounted
25 aft of said center of gravity.

According to another aspect of the invention, the propulsion and control system of these or other embodiments may be further configured for selectively changing the position of said center of gravity.

For example, and referring to the first embodiment of the propulsion and control
30 system, a relative position between said third propulsion unit and said tiltable propulsion units may be longitudinally adjustable, for example wherein said third propulsion unit is mounted to an aft end of said body via a first support structure, said first support structure being configured for adjusting a longitudinal spacing between

- 14 -

said third propulsion unit and said aft end. The first support structure may be configured for facilitating said adjusting, and may be optionally further configured for facilitating mounting and dismounting of said third propulsion unit with respect to said body by a ground crew. Optionally, said first support structure is configured for providing said
5 adjusting in an automated manner. Similar arrangements may be provide for the second embodiment of the propulsion and control system, *mutatis mutandis*.

Optionally, the air vehicle can be operated with the third propulsion unit removed.

According to the first aspect of the invention, there is also provided a method for
10 operating an air vehicle, comprising:

- providing an air vehicle according to the first aspect of the invention;
- operating said propulsion units to generate sufficient longitudinal thrust for enabling aerodynamic flight;
- augmenting said aerodynamic control moments by operating said propulsion
15 system for generating said variable control moments.

According to the second aspect of the invention, there is provided a modular air vehicle comprising:

- a body;
- a propulsion system;
- a group of modular wing sets, wherein each said modular wing set is configured
20 for being mountable in turn to said body for providing aerodynamic lift in forward flight, wherein one said modular wing set is selected from said group and selectively mounted to said body; and
- an empennage.

25 At least one said modular wing set may be configured for providing said air vehicle with a performance different from that provided by another said modular wing set.

Each said modular wing set may be configured for facilitating mounting and dismounting of the respective modular wing set to said fuselage by a ground crew,
30 although at least some embodiments can be configured for releasing the wings automatically, for example via explosive bolts, and thus dropping the wings when these are not desired, even while airborne – of course, lift for cruise is then provided by the propulsion system.

- 15 -

Such a propulsion system may comprise any suitable embodiment of the propulsion and control system according to the first aspect of the invention, for example.

According to the third aspect of the invention, there is provided a method for
5 operating an air vehicle, said vehicle comprising at least one propulsion unit having a rotary component whereby rotation of said rotary component generates a thrust for operation of the propulsion unit, said propulsion unit being tiltable about a tilt axis between a first thrust direction and a second thrust direction, said method comprising implementing a braking procedure to said rotary component such as to stop or
10 significantly reduce rotation thereof during at least a major portion of the tilting of said propulsion unit between said first thrust direction and said second thrust direction.

According to the third aspect of the invention, there is also provided an air vehicle comprising at least one propulsion unit having a rotary component whereby rotation of said rotary component is configured for generating a thrust for operation of
15 the propulsion unit, said propulsion unit being tiltable between a first thrust direction and a second thrust direction, and comprising a braking arrangement configured for stopping or significantly reducing rotation of said rotary component during at least a major portion of the tilting of said propulsion unit between said first thrust direction and said second thrust direction.

According to the third aspect of the invention, there is also provided at least one
20 propulsion unit for an air vehicle, the or each said propulsion unit having a rotary component whereby rotation of said rotary component is configured for generating a thrust for operation of the respective propulsion unit, the or each said propulsion unit being tiltable between a first thrust direction and a second thrust direction, and
25 comprising a braking arrangement configured for stopping or significantly reducing rotation of said rotary component during at least a major portion of the tilting of said propulsion unit between said first thrust direction and said second thrust direction.

The tilt axis may be substantially orthogonal to the rotational axis of the rotary component.

30 The said first thrust direction may correspond to a general horizontal thrust position correlated to aerodynamic flight, and said second thrust direction may correspond to a general vertical thrust position, correlated to vectored thrust flight.

In at least some embodiments according to the third aspect of the invention, the rotary component may comprise any one of: a propeller or a spool of a turboprop unit; a spool or fan of a turbofan unit; a spool of a turbojet unit; a propfan (unducted fan); a propeller (shrouded or unshrouded); and the like.

5 The system and method according to the first aspect of the invention may include one or more features of the modular air vehicle according to the second aspect of the invention, *mutatis mutandis*, in any desired combination, and/or may include one or more features of the air vehicle and/or propulsion unit and/or method according to the third aspect of the invention, *mutatis mutandis*, in any desired combination.

10 The modular air vehicle according to the second aspect of the invention may include one or more features of the system and/or method according to the first aspect of the invention, *mutatis mutandis*, in any desired combination, and/or may include one or more features of the air vehicle and/or propulsion unit and/or method according to the third aspect of the invention, *mutatis mutandis*, in any desired combination.

15 The air vehicle and/or propulsion unit and/or method according to the third aspect of the invention, may include one or more features of the modular air vehicle according to the second aspect of the invention, *mutatis mutandis*, in any desired combination, and/or may include one or more features of the system and/or method according to the first aspect of the invention, *mutatis mutandis*, in any desired
20 combination.

At least according to the first aspect of the invention, there is provided an air vehicle and methods of operation thereof based on a relatively simple base design concept which, at least for some embodiments, provides features of weight reduction and/or cost reduction and/or reliability, with respect to at least some known VTOL and
25 V/STOL design concepts. For example, in some embodiments the motor of each propulsion unit may be accommodated in a respective duct, which simplifies design and facilitates integration of the propulsion units to the airframe, reducing manufacturing costs and/or replacement costs.

30 In at least one application, the air vehicle according to the first aspect of the invention may be in the form of a UAV, for example a tactical UAV, and at least some embodiments of the air vehicle according to this aspect of the invention may have one or more of the following features:

- 17 -

- autonomous point vertical landing and takeoff, as well as regular take-off and landing;
- hover and slow flight capabilities, including vectored thrust flight at below-stall velocities;
- 5 - can compensate for gusts and winds;
- simplicity in design;
- low cost;
- can provide performance in aerodynamic flight with reduced number of control surfaces or no control surfaces;
- 10 - inherent fail safe configuration dependent on velocity/altitude conditions as per helicopters ("avoid curve") ;
- easy to maneuver with respect to obstacles;
- urban use;
- can be launched from a mobile platform – car, aircraft, helicopter, ship, carrier UAV, etc;
- 15 - no need for a special launcher system and/or a special capture system.

A feature of at least some embodiments according to the first and/or second and/or third aspects of the invention is that each respective tiltable propulsion unit may be configured having an external dimension and is located with respect to the aircraft in
20 a manner such as to allow the air vehicle to take off and to land also in a conventional aerodynamic flight manner (i.e., non-VTOL), in which the respective tiltable propulsion unit(s) provide the forward thrust for so doing. Thus, when each respective tiltable propulsion unit is tilted so that its respective thrust vector is aligned with the general thrust vector direction, there is vertical clearance between the lower part of the outer
25 profile of the respective tiltable propulsion unit and the ground when the air vehicle is in the parked position, for example.

BRIEF DESCRIPTION OF THE DRAWINGS

In order to understand the invention and to see how it may be carried out in
30 practice, embodiments will now be described, by way of non-limiting example only, with reference to the accompanying drawings, in which:

Fig. 1 is a front/top/side isometric view of an embodiment of the air vehicle of the invention in aerodynamic flight mode.

Fig. 2 is a front/top/side isometric view of the embodiment of Fig. 1, in vectored thrust flight mode.

5 **Figs. 3(a), 3(b), 3(c)** are a top view, front view and side view, respectively, of the embodiment of Fig. 1 in aerodynamic flight mode.

Fig. 4 is a front/top/side isometric view of the embodiment of Fig. 1 providing augmented roll control in aerodynamic flight mode.

10 **Fig. 5** is a front/top/side isometric view of the embodiment of Fig. 1 providing augmented yaw control in aerodynamic flight mode.

Fig. 6 is a front/top/side isometric view of the embodiment of Fig. 1 providing augmented pitch control in aerodynamic flight mode.

Figs. 7(a), 7(b), 7(c) are a top view, front view and side view, respectively, of the embodiment of Fig. 1 in vectored thrust flight mode.

15 **Fig. 8** is a front/top/side isometric view of the embodiment of Fig. 1 providing pitch control in vectored thrust flight mode.

Fig. 9 is a front/top/side isometric view of the embodiment of Fig. 1 providing yaw control in vectored thrust flight mode.

20 **Fig. 10** is a front/top/side isometric view of the embodiment of Fig. 1 providing roll control in vectored thrust flight mode.

Fig. 11 is a front/top/side isometric view of the embodiment of Fig. 1 providing forward/aft motion in vectored thrust flight mode.

25 **Fig. 12(a)** and **Fig. 12 (b)** are front/top/side isometric views of another embodiment of the air vehicle of the invention in aerodynamic flight mode and in vectored thrust flight mode, respectively.

Fig. 13 is a front/top/side isometric view of another embodiment of the air vehicle of the invention in aerodynamic flight mode.

Fig. 14 is a front/top/side isometric view of the embodiment of Fig. 13, in vectored thrust flight mode.

30 **Fig. 15** is an exploded view of the embodiment of Fig. 13; **Fig. 15a** is a cross-sectional view of a support structure of the embodiment of Fig. 13.

Fig. 16 illustrates a set of modular wing portions for use with the embodiment of Fig. 13.

DETAILED DESCRIPTION OF EMBODIMENTS

Referring to Figs. 1, 2, 3(a), 3(b), 3(c), 7(a), 7(b), 7(c) in particular, an air vehicle according to an embodiment of the invention, generally designated **100**,
5 comprises a main body in the form of fuselage **200**, a wing arrangement **300**, a propulsion system **400** and an empennage **500**.

In this embodiment the air vehicle **100** also comprises a suitable undercarriage such as a tricycle undercarriage (not shown), which may be fixed or retractable. In alternative variations of this embodiment, the air vehicle may be provided without an
10 undercarriage and comprises an alternative arrangement for cushioning a landing or is configured for landing onto a suitable cradle or soft cushioning material in VTOL configuration. In alternative variations of this embodiment, the air vehicle may be provided with a different undercarriage arrangement,

The air vehicle **100** has a roll axis z aligned with the longitudinal axis A of the
15 body or fuselage **200** and the direction of forward flight F , a pitch axis x , and a yaw axis y .

The air vehicle **100** in this embodiment is configured as a subsonic unmanned air vehicle (UAV), though in alternative variations of this embodiment the air vehicle may be manned and/or configured as a transonic and/or supersonic air vehicle.

20 The fuselage **200** comprises a nose **220** and an aft end **240**, and longitudinal axis A is generally parallel to the direction of forward flight F . The fuselage **200** comprises a generally oblate cross-sectional area taken along transverse planes generally orthogonal to the direction of forward flight F .

Wing arrangement **300** is a fixed wing arrangement, comprising a port wing
25 **320p** and a starboard wing **320s**, and thus, the port wing **320p** and the starboard wing **320s** are fixedly connected to the fuselage in a fixed geometrical relationship. It is to be noted that in alternative variations of this embodiment, the port wing **320p** and the starboard wing **320s** may be pivotably mounted to the fuselage to controllably change the sweep angle of the wings and optimize performance both in the low velocity and
30 high velocity aerodynamic flight regimes (so-called variable geometry wings). In these or other alternative variations of this embodiment, the port wing **320p** and the starboard wing **320s** may each comprise a number of spanwise sections, which may be folded

- 20 -

with respect to one another to minimize storage space, for example for parking in carriers and/or for facilitating stowage. In these or other alternative variations of this embodiment, the wings and fuselage may be in the form of a blended wing body (BWB) configuration.

5 In the illustrated embodiment, the port wing **320p** and the starboard wing **320s** are substantially identical mirror-images of one another, and thus unless specified otherwise, the reference numeral **320** will refer to each one of the wings **320s**, **320p**.

In the illustrated embodiment, and referring in particular to Fig. 3(a), each wing **320** has a chord **c** which is over 50% of the fuselage length **L**, and a forward portion **250** of the fuselage projects forward of the wings **320**. The wings **320** each have an aspect ratio of about 2.6, zero dihedral or anhedral, zero sweep, a wing root **310** and a wing tip **330**, span **I**, and control surfaces such as ailerons **345**. In alternative variations of this embodiment, the wings may also comprise other control surfaces such as for example leading edge slats, flaps, and so on, and/or may have positive or negative sweep, and/or anhedral or dihedral, and/or an aspect ratio different from 2.6.

15 Referring particularly to Figs. 3(a) to 3(c), empennage **500** comprises a pair of laterally spaced booms **520**, a port boom **520** connected to the port wing, and a starboard boom **520** connected to the starboard wing. Each boom **520** projects in an aft direction from the respective wing **320**, generally intermediate between the respective wing root and wing tip. A fin **540** is anhedrally mounted to each boom **520** at the respective boom aft end **545** so that the respective fin tip **548** is below and outboard with respect to the respective fin root **542**, and thus the two fins **540** are in diverging relationship. Each fin **540** comprises a control surface **543** at the trailing edge thereof that operates both as a rudder and as a vertical stabilizer in the aerodynamic flight regime of the air vehicle. Each boom **520** has a forward boom portion **560** that projects forward of the leading edge of the respective wing **320**. In alternative variations of this embodiment, any suitable alternative configuration for empennage **500** may be provided, taking into account the structure and function of the aft ducted fan unit **420c**.

25 Referring to Fig. 1 and Figs. 3(a) to 3(c), for example, propulsion system **400** is configured as a propulsion and control system for the air vehicle, and comprises three propulsion units in the form of three ducted fan units - a pair of forward-mounted vectored ducted fan units **420a**, **420b**, and a single, aft-mounted, non-tiltable ducted fan unit **420c**, in triangular spatial arrangement in plan view enclosing the center of gravity

- 21 -

CG of the air vehicle. In alternative variations of this embodiment, one propulsion unit (configured for providing vectored thrust or configured for providing fixed thrust vector) is provided at the front of the air vehicle, or at least forward of the center of gravity CG, and a pair of vectored thrust propulsion units is provided at the aft end, or at least aft of the center of gravity CG of the air vehicle.

In this embodiment, the ducted fan unit **420c** is located at the aft end of the fuselage **200**, for example to minimize drag, and is generally aligned vertically with the wings **320**, i.e., when longitudinal axis A is horizontal, the ducted fan unit **420c** is at about the same general height as the fuselage **200** and the wings **320**.

The air vehicle **100** further comprises a suitable control system (not shown) for operating the propulsion system **400**, in particular the magnitudes of each of the thrusts T_a , T_b , T_c generated by ducted fan units **420a**, **420b**, **420c**, respectively, independently of one another, and the thrust vectors V_a and V_b of the ducted fan units **420a**, **420b**, respectively, independently of one another.

Unless specified otherwise, the reference numeral **420** refers to each one of the ducted fan units **420a**, **420b**, **420c**. Each ducted fan unit **420** comprises a motor **421** centrally mounted within a respective duct **422** via internal struts **425**, the duct **422** having a duct inlet **423** and a duct outlet **424**. Each motor **421** is coupled to and powers a respective fan **426**, which in this embodiment has a plurality of blades **427** in fixed pitch relationship. In operation, each ducted fan unit **420** generates a thrust vector in the general direction from the respective duct outlet **424** to the respective duct inlet **423**, as the ducted fan units **420** have an absence of fixed vanes and/or an absence of movable vanes for controlling the thrust vector of the respective ducted fan unit **420**, though in alternative variations of this embodiment at least one ducted fan unit may comprise some fixed vanes. Each ducted fan unit **420** is configured for providing an individually controllable thrust level, which may be controllably increased or decreased from any suitable datum setting as required.

In alternative variations of this embodiment, at least one ducted fan unit **420** may comprise a plurality of fans driven by the respective motor.

In alternative variations of this embodiment, at least one ducted fan unit **420** may comprise a plurality of motors for driving the respective fan(s).

In the illustrated embodiment, all three ducted fan units **420** are configured as mutually co-rotating (i.e., the fans all turn in the same direction with respect to the duct)

- 22 -

and are of similar construction (except for the mounting arrangement to the air vehicle), simplifying manufacture and logistics, and reducing manufacturing and ownership costs.

The air vehicle **100** is also configured for providing a braking procedure to each ducted fan unit **420**, thereby enabling the motor **421** of each ducted fan unit **420** to be stopped or at least considerably slowed down, in a relative short time period, for example less than 1 second, thus destroying or significantly reducing the angular momentum of the motor rotor and fan **426**. In some alternative variations of this embodiment, the braking feature is only provided for each ducted fan unit that is tiltable with respect to the fuselage.

For example, the braking feature may comprise a braking arrangement in the form of a mechanical brake provided with the respective motor **421**, which, when actuated, stops (or significantly reduces) the rotation of the rotor of the respective motor **421** and thus also of the respective fan **426**. Additionally or alternatively, and particularly in embodiments where the motor **421** is a DC electric motor, the braking feature may comprise suitably reversing the direction of the current provided to the motor and then switching off the motor, or may instead comprise providing a short circuit to the motor via the respective electronic speed control (ESC), which stops the motor. Alternatively, the braking feature may comprise switching off the motor, and using the drag and/or friction acting on the spinning fan **426** for braking the rotational speed thereof. The purpose of this braking feature will become clearer below.

In the illustrated embodiment, the thrust generated by each of the three ducted fan units **420** may be variably adjusted by independently controlling the rpm of the respective motor, and thus of the respective fan **426**. In alternative variations of this embodiment, at least one fan comprises a plurality of variable pitch blades, and the thrust generated by the respective fan may be variably adjusted by controlling the rpm and/or by controlling the pitch of the blades.

The aft ducted fan unit **420c** is attached to the fuselage aft end **240** in fixed spatial orientation with respect thereto, such that the thrust vector V_{Vc} of ducted fan unit **420c**, and the rotational axis of its respective fan **427**, is fixed generally parallel to the yaw axis y or slightly inclined thereto and pointing in a generally upwards direction with respect to the fuselage **200**. In this embodiment, and referring to Figs. 3(b) and 3(c) in particular, the thrust vector V_{Vc} of ducted fan unit **420c** (and the rotational axis of its

- 23 -

respective fan 427), is fixedly inclined (at least selectively fixedly inclined) in a forward direction by an acute angle ϕ_1 along the z-y plane, and in a lateral direction by an acute angle ϕ_2 along the x-y plane with respect to the yaw axis. A feature of having the forward tilt of angle ϕ_1 along the z-y plane is that the air vehicle may hover with the nose 220 in a slight nose-up position when the thrust vector V_{Vc} is vertical, providing a positive angle of attack for the wings, and thus maximizes or at least makes further use of wing lift that may be generated as a result of any wind that flows over the air vehicle, thus reducing part of the need for vectored thrust during hover. A feature of having the sideways tilt of angle ϕ_2 along the x-y plane is that this provides a thrust vector component in the pitch axis direction that can be used to compensate for a baseline yaw that is naturally generated by the co-rotation of the fans of three fan units during hover at a particular design point – further compensation at conditions off this design point may be provided by the forward fan units, as will be described below in greater detail.

In this or other alternative variations of this embodiment, the aft ducted fan unit 420c may be further configured for being controllably tilted about a pitch axis to provide a horizontal thrust vector for providing propulsion in the forward flight direction F, for example, and/or may be configured for being controllably tilted about a roll axis to provide a horizontal thrust vector in a direction parallel to the pitch axis x to provide yawing moments and/or side slip movements.

Forward ducted fan unit 420a is rotatably mounted between the fuselage forward portion 250 and the respective forward boom portion 560 of the port wing 320p via journals 450a, to enable the ducted fan unit 420a to be reversibly tilted about axis X_a with respect to the fuselage 200 about any desired tilt angle α , at least between a tilt angle α of zero degrees and 90 degrees. Tilt angle α of zero degrees corresponds to the general vertical thrust position shown in Fig. 2 in which the thrust vector V_{Va} is substantially parallel to the yaw axis y, and tilt angle α of 90 degrees corresponds to the general longitudinal thrust position shown in Fig. 1 in which the thrust vector V_{Ha} is substantially parallel to the roll axis z and points in direction F. Axis X_a is substantially parallel to the pitch axis x of the air vehicle 100 and intersects the rotational axis of the respective fan 426. Optionally, the ducted fan unit 420a may be further tilted about axis X_a in either direction past the horizontal thrust position or past the vertical thrust position to provide a thrust vector V_a at any other suitable angle to the longitudinal axis

- 24 -

A, for example such as to provide any thrust vector including a partial or full downward thrust (angle α between about 90 degrees and about 270 degrees) or a partial or full reverse thrust (angle α between about 0 degrees and about -180 degrees (or between about 180 degrees and about 360 degrees)) i.e. in a direction opposite to direction F.

5 A suitable drive mechanism (not shown) is provided for independently and controllably driving the tilting of each of the two forward ducted fan units **420a** and **420b** to controllably vary the respective thrust vector, i.e., the angular position of the respective thrust generated by the respective propulsion unit, independently of one another. The drive mechanism is configured for tilting the ducted fan units **420a** and
10 **420b** in a relatively fast manner, and provide very quick and accurate response to tilting commands (in terms of direction and angular displacement) provided by the control system.

Forward ducted fan unit **420b** is rotatably mounted between the forward portion **250** and the respective forward boom portion **560** of the starboard wing **320s** via
15 journals **450b**, to enable the ducted fan unit **420b** to be reversibly tilted about axis X_b with respect to the fuselage **200** about any desired tilt angle β , at least between a tilt angle β of zero degrees and **90** degrees. Tilt angle β of zero degrees corresponds to the vertical thrust position shown in Fig. 2 in which the thrust vector V_{Va} is substantially parallel to the yaw axis y , and tilt angle β of 90 degrees corresponds to the horizontal
20 thrust position shown in Fig. 1 in which the thrust vector V_{Ha} is substantially parallel to the roll axis and points in direction F. Axis X_b is substantially parallel to the pitch axis x of the air vehicle **100** and intersects the rotational axis of the respective fan. Optionally, the ducted fan unit **420b** may be further tilted about axis X_b in either direction past the horizontal thrust position or the vertical thrust position to provide a thrust vector V_b at
25 any other suitable angle to the longitudinal axis A, for example such as to provide any thrust vector including a partial or full downward thrust (angle β between about 90 degrees and about 270 degrees) or a partial or full reverse thrust (angle β between about 0 degrees and about -180 degrees (or between about 180 degrees and about 360 degrees)) i.e. in a direction opposite to direction F.

30 In at least this embodiment, the tilt axes X_a , X_b are coaxially aligned.

In alternative variations of this embodiment, the tilt axes X_a , X_b may be each set at a modest angle to the pitch axis x and/or yaw axis y and/or roll axis z so as to provide

- 25 -

a desired thrust vector component along one or more of the roll, pitch or yaw axes, respectively. For example, it may be desired to have the thrust vectors V_a and V_b in the vertical thrust position in a mutually converging or diverging relationship when viewed from the front of the air vehicle. Converging thrust vectors may delay the formation of an upwash fountain between the front propulsion units, while diverging thrust vectors may provide natural stability in roll during landing and take-off, for example.

The motors **421** for the three ducted fan units **420a**, **420b**, **420c** may each be electrically powered (i.e., the motors may be electric motors) or fuel powered (for example the motors may be combustion engines), or each ducted fan unit may comprise a hybrid motor. Alternatively, the motors **421** may be different one from another, and the three ducted fan units **420a**, **420b**, **420c** may include a permutation between the three types of motor and/or different types of motor, for example aft ducted fan unit **420c** may be fuel powered, while the forward ducted fan units **420a**, **420b** may be electric motors, or aft ducted fan unit **420c** may be an electric motor, while the forward ducted fan units **420a**, **420b** may be fuel powered. In each case, power or fuel to the motor **421** is provided from a suitable electrical power supply or fuel tank, respectively, comprised in the fuselage **200** and/or wings **320** via suitable lines, typically routed to the respective motor **421** via one or more respective struts **425**.

In alternative variations of this embodiment, the motors may be located outside of the ducted fan unit, for example in the fuselage or wings, and are coupled to the respective fan via a suitable coupling, for example a rotatable coupling for allowing the forward mounted ducted fan units to tilt.

In this embodiment, the air vehicle **100** further comprises a payload **600** in the form of a surveillance package, comprising image acquisition system **610** enclosed in a suitable radome or fairing **620**, provided on the underside of the air vehicle, close to the nose thereof. For example, image acquisition system **610** may include one or more optical or IR imaging cameras which are pointing in the general Earth direction. In alternative variations of this embodiment, the payload may be omitted, or alternatively may be located at a different position on the fuselage or wings, or alternatively a different payload may be provided, internally or externally of the fuselage and/or the wings; such a payload may comprise, for example, sensors, radar systems, COMINT equipment, electronic countermeasures, stores, delivery system therefor, and so on.

- 26 -

The air vehicle **100** is configured for controllably, selectively and independently varying the thrust vectors V_a and V_b by the changing tilt angle α independently from tilt angle β . This feature provides at least differential and selective tilt control for the thrust vectors generated by each one of the forward ducted fan units **420a**, **420b**,
5 independently of the other forward ducted fan unit. Nevertheless, the forward ducted fan units **420a**, **420b** can also be operated to tilt together in the same direction and through the same or different angular displacement one from the other. Furthermore, the air vehicle **100** is configured for controllably and selectively changing the magnitude of the thrust T_a , T_b , T_c generated by each of the ducted fan units **420a**, **420b**, **420c**,
10 respectively, independently of one another. The air vehicle **100** is also configured for controllably and selectively changing the magnitude of the thrust T_a , T_b , generated by each of the forward ducted fan units **420a**, **420b**, respectively, independently of one another, and also independently of the magnitude of the respective tilt angles α , β thereof, i.e., of the thrust vectors V_a and V_b , which may also be controllably and
15 selectively varied independently one from the other .

Referring to Fig. 3(b) and 3(c), for example, it is evident that in the illustrated embodiment the forward ducted fan units **420a**, **420b** are mounted at a position with respect to the wings and fuselage, and have a particular external profile, in particular an external dimension, that allows the air vehicle to take off and to land (in non-VTOL
20 mode) with the forward ducted fan units **420a**, **420b** providing the required thrust for aerodynamic flight, without colliding with the ground. In other words, the external dimension (in this case outer diameter) of the forward ducted fan units **420a**, **420b** is sufficiently small, given the location of the forward ducted fan units **420a**, **420b** on the air vehicle, such as to provide a vertical clearance between the forward ducted fan units
25 **420a**, **420b** and the ground, at least when the air vehicle is parked. This allows the air vehicle to be operated fully also as a conventional (non-VTOL) air vehicle.

The air vehicle **100** may be operated at least in an aerodynamic flight regime, in a vectored thrust flight regime, and in an augmented aerodynamic flight regime, for example as follows.

30

Aerodynamic Flight Mode

- 27 -

In the aerodynamic flight regime, the air vehicle **100** may be operated exclusively in aerodynamic flight mode (also referred to herein as "aerodynamic flight"), in which the air vehicle has sufficient forward velocity to enable sufficient aerodynamic lift to be generated by the air vehicle, in this embodiment by the wings **320**, and for pitch roll and yaw control to be provided via the control surfaces **345** and **543**. The two forward mounted ducted fan units **420a**, **420b** are in nominal horizontal or longitudinal mode, with the respective tilt angles α , β nominally set at 90 degrees, to provide thrust vectors V_{Ha} and V_{Hb} , respectively in the general forward flight direction F , and thrusts T_a and T_b are nominally equal. In this flight mode, the air vehicle **100** operates within its flight envelope in a similar manner to that of conventional fixed-wing aircraft.

The aft ducted fan unit **420c** may be inoperative in the aerodynamic flight mode, or alternatively may be operated to generate zero thrust or close thereto, for example by suitably pitching the fan blades **427** in embodiments where these are configured as variable pitch blades, and/or by reducing the rpm of the fans. Particularly in alternative variations of this embodiment in which the air vehicle is configured for operating as a transonic and/or supersonic air vehicle, suitable covers may be provided for closing the duct outlet and the duct inlet of the aft ducted fan unit **420c**, to reduce drag.

In the illustrated embodiment, the fans **426** of the three ducted fan units **420** are co-rotating with respect to one another, i.e., rotate in the same direction. In aerodynamic flight mode, the co-rotation of the fans **426** of the forward mounted ducted fan units **420a**, **420b** can lead to an undesired roll, and this effect can be compensated for in this embodiment in at least two ways. According to one such way or method, a compensating roll is provided to the air vehicle **100** by differentially tilting the ducted fan units **420a**, **420b** in opposite directions about the nominal respective tilt angle 90 degree positions. This varies the direction of the thrust vector V_a provided by forward ducted fan unit **420a** relative to the direction of the thrust vector V_b provided by forward ducted fan unit **420b**, and thus creates two thrust components that form a couple in the opposite sense to the roll induced by the co-rotating fans. The tilt angles may be chosen so that the couple equalizes and thus cancels the induced roll. In a second way or method, the control surfaces **345** and **543** are operated to compensate for the induced roll. In alternative variations of the illustrated embodiment, the fans **426** of the forward

- 28 -

mounted ducted fan units **420a**, **420b** can be configured to rotate in opposite directions, and thus do not generate the aforesaid undesired roll.

Vectored Thrust Flight Mode

5 In the vectored thrust flight regime, the air vehicle **100** may be operated exclusively in vectored thrust flight mode (also referred to herein as "vectored thrust flight", or as "VTOL operations"), in which all the lift, movement and control of the air vehicle are provided by the propulsion system **400**, under the control of the control system.

10 For VTOL operations, the forward ducted fan units **420a**, **420b** are tilted to the nominal vertical position, in which tilt angles α , β are set at nominally zero degrees, and all three ducted fan units **420** provide vertical thrust. In the illustrated embodiment, the center of gravity CG of the air vehicle is located generally centrally with respect to the three ducted fan units **420a**, **420b**, **420c** (see Fig. 7(a)), and thus the three ducted fan
15 units generate nominally the same thrust levels: for VTOL take-off the combined thrust of the three ducted fan units initially exceeds the take-off weight of the air vehicle to provide an upward velocity, after which the combined thrust may be balanced with the weight. For VTOL landing, the combined thrust that may be generated by the three ducted fan units is reduced to less than the weight of the air vehicle to provide a
20 downward velocity (after which the thrust may be balanced to the weight), sufficient to at least guarantee a soft landing during regular operation of the air vehicle **100**.

In alternative variations of this embodiment, where the center of gravity is located closer to or further away from the aft ducted fan unit **420c** than with respect to the forward ducted fan units **420a**, **420b**, and the ratio of the thrust provided by the aft
25 ducted fan unit **420c** relative to the forward ducted fan units **420a**, **420b** is correspondingly such as to provide pitch balance to the air vehicle. The relative thrust split between the aft ducted fan unit **420c** relative to the forward ducted fan units **420a**, **420b** can also be controlled to offset a longitudinal shift in the position of the CG, for example related to the location, size or absence of the payload. Additionally or
30 alternatively, the relative thrust split between the two forward ducted fan units **420a**, **420b** can also be controlled to offset a lateral shift in the position of the CG that is for example inherent in the air vehicle design or that is related to the location, size or

- 29 -

absence of the payload – for example where a stores on one wing is jettisoned while retaining a similar stores on the other wing.

In the vectored thrust flight regime, the propulsion system **400** also allows the air vehicle **100** to hover over an area, and also to move in a forward or aft direction, and/or to move in a port or starboard side direction, and/or to increase or decrease the altitude of the air vehicle **100**, and/or to provide pitch, yaw and roll control to the air vehicle **100**.

Hovering over a fixed area is accomplished by maintaining the combined thrust of the propulsion system **400** balanced with the weight of the air vehicle **100**, and changes in altitude are provided by selectively increasing or decreasing the combined thrust until the desired rate of climb is achieved, after which the combined thrust is against balanced with the air vehicle weight, followed by deceleration to eliminate climb at the desired altitude.

Referring to Fig. 8, pitch control of the air vehicle **100** is provided by varying the ratio of the moment provided by the aft ducted fan unit **420c** relative to the combined moment of the forward ducted fan units **420a**, **420b**, while their tilt angles are nominally set at zero degrees. Since in this embodiment the moment arms of the various ducted fan units is constant, pitch control is provided by varying the ratio of thrust T_c provided by the aft ducted fan unit **420c** relative to the combined thrust $(T_a + T_b)$ of the forward ducted fan units **420a**, **420b** – nose up pitch is generated when T_c is less than $(T_a + T_b)$, and vice versa, i.e., nose down pitch is generated when T_c is greater than $(T_a + T_b)$. In alternative variations of this embodiment in which at least one propulsion unit is mounted to the air vehicle in a manner allowing for the moment arm thereof with respect to the center of gravity to be varied, pitch control may be provided by varying the ratio of the moment arm of the aft unit with respect to the moment arm of the forward units, and/or by suitably varying the ratio of the thrusts.

Referring to Fig. 9, yaw control of the air vehicle **100** is provided by varying the direction of the thrust vector V_a provided by forward ducted fan unit **420a** relative to the direction of the thrust vector V_b provided by forward ducted fan unit **420b**, i.e., by differentially tilting the ducted fan units **420a**, **420b** about the nominal respective tilt angle zero degree positions. Yaw in one direction is generated when tilt angle α is positive and tilt angle β is negative, such that the respective thrust vectors T_a , T_b have a forward component and an aft component, respectively, and vice versa. During a pure

- 30 -

yaw maneuver, the propulsion system is operated to maintain a balance (in pitch and roll), and the aft ducted fan unit **420c** and/or the forward ducted fan units **420a**, **420b** may be operated such that the vertical thrust component of combined thrust ($T_a + T_b$) of the forward ducted fan units **420a**, **420b** balances that of thrust T_c , and such that the
5 vertical thrust components of thrusts T_a and T_b are substantially balanced.

Referring to Fig. 10, roll control of the air vehicle **100** is provided by varying the ratio of the moment provided by forward ducted fan unit **420a** relative to the moment provided by forward ducted fan unit **420b**, while their tilt angles are nominally set at zero degrees, in this embodiment by varying the ratio of the thrust T_a provided by
10 forward ducted fan unit **420a** relative to the thrust T_b provided by forward ducted fan unit **420b**. Roll in one direction is generated when T_a is greater than T_b , and vice versa. During a pure roll maneuver, the propulsion system is operated to maintain a balance (in pitch), and the aft ducted fan unit **420c** and/or the forward ducted fan units **420a**, **420b** may be operated such that the vertical thrust component of combined thrust ($T_a + T_b$) of
15 the forward ducted fan units **420a**, **420b** balances that of thrust T_c . In alternative variations of this embodiment in which at least one propulsion unit is mounted to the air vehicle in a manner allowing for the moment arm thereof with respect to the center of gravity to be varied, roll control may be provided by varying the ratio of the moment arm of one forward unit with respect to the moment arm of the other forward unit,
20 and/or by suitably varying the ratio of the thrusts.

Referring to Fig. 11, forward and aft motion of the air vehicle **100** in hover is provided by varying the direction of the thrust vectors V_a , V_b of the thrust provided by forward ducted fan units **420a**, **420b**, respectively, in the same manner, i.e., by tilting
25 the two ducted fan units **420a**, **420b** in the same direction about the nominal respective tilt angle zero degree positions. Movement in the forward direction is generated when tilt angles α and β are positive, such that the respective thrusts T_a , T_b both have a forward component, and vice versa. The magnitude of the tilt angles α and β are the same if the thrust generated by the two forward ducted fan units **420a**, **420b** are also the
30 same; alternatively, providing different magnitudes for angles α and β may be compensated by providing different magnitudes for the respective thrust vectors V_a , V_b . During a pure forward or aft maneuver, the propulsion system is operated to maintain a

- 31 -

balance (in pitch, roll and yaw), and the aft ducted fan unit **420c** and/or the forward ducted fan units **420a**, **420b** may be operated such that the vertical thrust component of combined thrust ($T_a + T_b$) of the forward ducted fan units **420a**, **420b** balances that of thrust T_c , and such that the vertical thrust components of thrusts T_a and T_b are substantially balanced, and such that the horizontal thrust components of thrusts T_a and T_b are substantially balanced.

Additionally or alternatively, forward or aft motion of the air vehicle **100** in hover may be provided by first inducing a pitch maneuver as disclosed above with reference to Fig. 8, so that the air vehicle is pitched to a particular pitch angle, nose down for forward motion (and nose up for aft motion), such that, maintaining this pitch angle, each thrust T_a , T_b , T_c , now has a forward component (or aft force component, respectively) to provide the desired forward motion (or aft motion, respectively) to the air vehicle.

Lateral or sideways motion (i.e., in a direction parallel to the pitch axis) of the air vehicle **100** in hover is provided by first inducing a roll maneuver as disclosed above with reference to Fig. 10, so that the air vehicle is rolled to a particular roll angle, such that, maintaining this roll angle, each thrust T_a , T_b , T_c , now has a lateral force component to provide the desired lateral motion to the air vehicle.

It is clearly evident that the air vehicle may be operated to provide any suitable forward/aft motion, and/or lateral movement, and/or pitch, and/or yaw, and/or roll, by suitably combining the operations of the propulsion system **400** as disclosed above regarding Figs. 8 to 11. Furthermore, during a pitch and/or roll and/or yaw maneuver, the propulsion system may be operated to maintain the required overall thrust.

In the illustrated embodiment, the fans **426** of the three ducted fan units **420** are co-rotating with respect to one another, i.e., rotate in the same direction with respect to one another. In hover mode, the co-rotation of the fans **426** may generate an undesired yaw, and this effect can be compensated in a number of ways, for example as follows. A compensating yaw may be provided to the air vehicle **100** by differentially tilting the ducted fan units **420a**, **420b** about the nominal respective tilt angle zero degree positions. This varies the direction of the thrust vector V_a provided by forward ducted fan unit **420a** relative to the direction of the thrust vector V_b provided by forward ducted fan unit **420b**, and thus creates two horizontal thrust components (in opposite

- 32 -

directions) that form a couple in the opposite sense to the yaw induced by the co-rotating fans.

As mentioned above, the aft ducted fan unit **420c** may be fixed with its thrust axis having a fixed sideways tilt of angle ϕ_2 along the x-y plane, which provides a thrust
5 vector component parallel to the pitch axis direction that can be used to partially or fully compensate for this yaw. For example, this yaw compensation feature of the aft ducted fan unit **420c** may be used for compensating for the yaw that is naturally generated by the co-rotation of the fans of three fan units during hover at a particular design point, while further compensation at conditions off this design point may be provided by
10 differentially tilting the ducted fan units **420a**, **420b** about the nominal respective tilt angle zero degree positions as described above to provide the desired additional yaw compensation (which may be to increase or decrease the yaw compensation provided by the aft ducted fan unit **420c**, as desired).

Alternatively, the aft ducted fan unit **420c** may be provided with a particular
15 sideways tilt angle ϕ_2 along the x-y plane, such as to provides a thrust vector component in the pitch axis direction that can be used to compensate for the yaw induced by the aft duct unit **420c**, and differentially tilting of the ducted fan units **420a**, **420b** about the nominal respective tilt angle zero degree positions may be provided as described above, *mutatis mutandis*, to provide yaw compensation for the yaw induced by the two co-
20 rotating fans of the ducted fan units **420a**, **420b** (in alternative variations of the embodiment, the ducted fan units **420a**, **420b** may have mutually counter-rotating fans, so that no net yaw is generated by the rotation of the fans, and thus no additional compensation is required).

25 **Augmented Aerodynamic Flight Mode**

In the augmented aerodynamic flight regime, the air vehicle **100** may be operated in augmented aerodynamic flight mode, in which control of the air vehicle is augmented or fully provided by the propulsion system **400**, under the control of the control system.

30 Thus, and referring to Figs 4 to 6, the propulsion system **400** can also be used to augment the operation of control surfaces **345** and **543** to provide enhanced pitch, roll and yaw control also when the air vehicle is operating in the aerodynamic flight mode. Alternatively, the air vehicle **100** may be designed with weaker aerodynamic direction

- 33 -

control, for example having smaller control surfaces **345** and **543** (than would otherwise be required in the absence of the aforementioned augmented control provided by propulsion system **400**), which can provide weight and cost advantages, and pitch/yaw and roll control is supplemented by means of the propulsion system **400**. Alternatively, 5 the air vehicle **100** may be designed with no aerodynamic direction control, i.e. without having control surfaces **345** and **543**, which can provide weight and cost advantages, and pitch/yaw/roll control is provided exclusively by means of the propulsion system **400**. Alternatively, the air vehicle **100** may be designed with the control surfaces **345** and **543** as a redundant direction control system, for use in case of failure of the 10 direction control otherwise provided exclusively by the propulsion system **400**, or vice versa, where the propulsion system **400** is operated as a redundant direction control system, for use in case of failure of the aerodynamic direction control provided by the control surfaces **345** and **543**.

For example, as illustrated in Fig. 4, augmented roll control of the air vehicle 15 **100** (in addition to or instead of roll control provided by control surfaces **345** operating as ailerons) is provided by varying the direction of the thrust vector V_a provided by forward ducted fan unit **420a** relative to the direction of the thrust vector V_b provided by forward ducted fan unit **420b**, i.e., by differentially tilting the ducted fan units **420a**, **420b** about the nominal respective tilt zero degree positions. Roll in one direction is 20 augmented when tilt angle α is less than 90 degrees and tilt angle β is more than 90 degrees, such that the respective thrust vectors V_a , V_b have an upward component and a downward component, respectively (in front view), and vice versa. Where the thrusts T_a , T_b provided by the front ducted fan units **420a**, **420b** are equal, the magnitude of the respective tilt angles above and below the 90 degree position is the same.

25 Referring to Fig. 5, augmented yaw control of the air vehicle **100** (in addition to or instead of roll control provided by control surfaces **543** operating as a rudder) is provided by varying the ratio of the moment, specifically thrust T_a provided by forward ducted fan unit **420a** relative to the moment, specifically thrust T_b provided by forward ducted fan unit **420b**, while their tilt angles are nominally set at 90 degrees. Yaw in one 30 direction is generated when T_a is greater than T_b , and vice versa.

Referring to Fig. 6, augmented pitch control of the air vehicle **100** (in addition to or instead of pitch control provided by control surfaces **543** operating as an elevator) is provided by varying the direction of the thrust vectors V_a , V_b provided by forward

- 34 -

ducted fan units **420a**, **420b**, in the same manner, i.e., by tilting the two ducted fan units **420a**, **420** in the same direction about the nominal respective tilt angle **90** degree positions. Nose down pitch moment is provided when angles α and β are greater than 90 degrees, such that the respective thrust vectors V_a , V_b have a downward component, and vice versa. The magnitude of the tilt angles α and β are the same if the thrust generated by the two forward ducted fan units **420a**, **420b**; alternatively, providing different magnitudes for angles α and β may be compensated by providing different magnitudes for the respective thrust vectors V_a , V_b .

Augmented pitch control of the air vehicle **100** (in addition to or instead of pitch control provided by control surfaces **543** operating as an elevator) may also be provided by actuation of the aft ducted fan unit **420c**. Rotation of the fan of the aft ducted fan unit **420c** in one direction produces an upward thrust and thus a nose-down pitching moment, while rotation of the fan in the opposite direction results in a nose-up pitching moment. In alternative variations of this embodiment, in which the fan of the aft ducted fan unit **420c** has variable pitch blades, the blades may be selectively controlled to alternately generate thrust in mutually opposite directions, respectively.

It is clearly evident that the air vehicle **100** may be operated to augment or provide any suitable pitch, and/or yaw, and/or roll, by suitably combining the operations of the propulsion system **400** as disclosed above regarding Figs. 4 to 6.

In augmented aerodynamic flight mode, the air vehicle **100** may also be operated to enable STOL operations, for example by supplementing lift generated by the wings during STOL take off and landing by providing lift vectors V_a and V_b greater than zero degrees but less than 90 degrees, to provide a suitable thrust component of the combined thrust ($T_a + T_b$) in the upward vertical direction. In addition, or alternatively, the aft ducted fan **420c** may be used to provide additional thrust T_c . The air vehicle **100** may be operated in a similar manner to augment lift in forward flight when it is desired to operate the aircraft at low velocity that is insufficient to provide the desired aerodynamic lift.

In alternative variations of this embodiment, in which the air vehicle may lack wings for providing aerodynamic lift, the vehicle can operate in the aforesaid augmented aerodynamic flight regime, for providing full lift and control via the propulsion system.

Transition between Aerodynamic Flight Mode and Vectored Thrust Flight Mode

The air vehicle **100** is configured for performing transition between aerodynamic flight mode and vectored thrust mode in a manner that is per se novel.

5 When making the transition from vectored thrust flight mode to aerodynamic flight mode, for example when wishing to provide forward (aerodynamic) flight after taking off or hovering, the tiltable ducted fan units **420a**, **420b** are rotated about their respective axes X_a , X_b through tilt angles α and β , respectively, each from the nominal vertical position of zero degrees to the nominal horizontal position of 90 degrees.

10 However, at the start of this tilting operation (or alternatively immediately before or immediately after the start), a braking procedure is implemented in which the respective rotor of motors **421** and the respective fans **426** are very quickly prevented from rotating at high speed, so that their angular momentum is brought down to zero or close thereto in a very short period of time. That is, at most the ensuing reduced angular

15 momentum after the braking procedure is a very small proportion of the angular momentum of the respective fan and motor rotor during the vectored thrust flight mode just preceding the braking procedure – such a proportion may be 50%, preferably 40%, more preferably 30%, more preferably 20%, more preferably 10%, more preferably 5%, more preferably 1%, more preferably less than 1%. As soon as the ducted fan units

20 **420a**, **420b** have been rotated to the aerodynamic flight mode positions, the respective motors **421** are immediately activated and run up to the required rpm to provide the required thrust for forward flight.

The transition from vertical thrust to horizontal thrust (also referred to herein as longitudinal thrust) for the ducted fan units **420a**, **420b** is initiated after the air vehicle

25 **100** is provided with sufficient forward motion with respect to the surrounding air such as to enable the wings to generate sufficient lift to support the weight of the air vehicle. This may be accomplished, for example by providing forward motion in hover as described above with reference to Fig. 11 or Fig. 8, *mutatis mutandis*, and/or use may be made of suitable wind conditions when available to provide the required lift. Thus,

30 during the transition, where very little or no thrust is being provided by the ducted fan units **420a**, **420b**, the air vehicle is supported by aerodynamic lift, and this can be subsequently further increased by the forward propulsion provided by ducted fan units **420a**, **420b** in horizontal thrust mode.

- 36 -

When making the transition from aerodynamic flight mode to vectored thrust flight mode, for example when wishing to land or hover after being in forward (aerodynamic) flight, the tiltable ducted fan units **420a**, **420b** are rotated about their respective axes X_a , X_b in the reverse direction, through tilt angles α and β , each from
5 nominally 90 degrees to nominally zero degrees, and during this transition the motor rotors of the respective motors **421** as well as the respective fans **426** are subjected to the aforesaid braking procedure, after which the respective motors **421** are immediately activated and run up to the required speed to provide the required thrust for vectored thrust mode. The forward momentum of the air vehicle prior to the transition is
10 sufficient to ensure that enough aerodynamic lift is generated for supporting the air vehicle during transition.

At least in this embodiment, transition between aerodynamic flight mode and vectored thrust flight mode is effected when the air vehicle has a forward velocity greater than the stall speed.

15 A feature of the braking procedure is that minimizes or reduces to zero the gyroscopic forces on the tiltable ducted fan units **420a**, **420b** during this transition relative to what the gyro forces would be if the motor rotors and fans were still spinning at or close to their original rpms, and reduces the energy required for performing the transition, as well as the elapsed time thereof. In turn, the journals **450a**, **450b** can be
20 correspondingly less massive than would otherwise be the case, and the drive mechanism for tilting the ducted fan units **420a**, **420b** can be less powerful, and typically smaller and lighter, than would otherwise be the case.

In alternative variations of this embodiment, the ducted fan units **420a**, **420b** can each be rotated between the vertical thrust and horizontal thrust positions while
25 continuously providing thrust, the respective thrust vector changing between zero and 90 degrees.

It is to be noted that the ducted fan units **420a**, **420b** can be rotated about any desired tilt angle α , β respectively, ranging from (and including) zero to 90 degrees, or less than zero, or beyond 90 degrees, as desired, and remain at these respective tilt
30 angles. The aforementioned brake procedure may be implemented to stop or minimize the rotation of the motors and fans while the ducted fan units **420a**, **420b** are being rotated, and the motors and fans are reactivated immediately upon reaching the desired tilt angles. Alternatively and particularly when using the ducted fan units **420a**, **420b** for

- 37 -

yaw/pitch/roll control, and/or where the tilt angles are relatively small, the ducted fan units **420a**, **420b** can each be rotated through the desired tilt angles while continuously providing thrust.

By way of non-limiting example of the embodiment of Figs. 1-11, the wingtip-
5 to-wingtip wingspan may be between about 1.5 and about 2.5 meters, fuselage length may be about 1 meter, overall maximum take off weight of the air vehicle may be about 8.5 Kg (which can includes a payload of about 2Kg, for example), the motors of each propulsion unit may comprise a A40 8-Pole motor (Heli version), provided by HACKER of Germany, powered by 3 or 4 eXtreme V2 batteries provided by Thunder
10 Power of USA, and controlled by a Phoenix HV-110 control unit, provided by Castle Creations of USA. By way of further non-limiting example, such an embodiment for the air vehicle may hover for about 12 minutes or fly for about 2 hours with fully charged batteries.

15 Another embodiment of the air vehicle, designated by the reference numeral **800** and illustrated in Figs. 12(a) and 12(b), has all the elements and features of the embodiment illustrated in Figs. 1 to 11, and is operated in a similar manner thereto, *mutatis mutandis*, with the following difference. The air vehicle **800** thus comprises fuselage **820**, wing arrangement **830**, propulsion system **840** and payload **860**,
20 substantially similar to fuselage **200**, wing arrangement **300**, propulsion system **400** and payload **600**, respectively, as disclosed for the embodiment illustrated in Figs. 1 to 11, and alternative variations thereof, *mutatis mutandis*. However, empennage **850** of the embodiment of Figs. 12(a) and 12(b) is different from empennage **500** in that, while empennage **850** also comprises a pair of laterally spaced booms (one connected to the
25 port wing, and one connected to the starboard wing; each boom having a forward boom portion that projects forward of the leading edge of the respective wing) and each boom projects in an aft direction from the respective wing, generally intermediate between the respective wing root and wing tip, the structure at the aft end of the booms is different. In this embodiment, a fin **854** is also anhedrally mounted to each boom at the respective
30 boom aft end, but in converging relationship with respect to the other fin **854**, so that the respective fin tip **848** is below and inboard with respect to the respective fin root **842**, rather than outboard. Furthermore, a horizontal stabilizer **841** is provided joining the two fin tips **848**. As with the embodiment illustrated in Figs. 1 to 11, each fin **854**

- 38 -

comprises a control surface at the trailing edge thereof that operates both as a rudder and as a vertical stabilizer in the aerodynamic flight regime of the air vehicle, though in alternative variations of this embodiment the fins **854** may lack a control surface. The horizontal stabilizer **841** may be non-adjustable, or alternatively may comprise a control surface such as an elevator to augment or replace the elevator operation of the control surfaces of the fins **854**.

Another embodiment of the air vehicle, designated by the reference numeral **900** and illustrated in Figs. 13, 14 and 15, has all the elements and features of the embodiment illustrated in Figs. 1 to 12(b) and may be operated in a similar manner thereto, *mutatis mutandis*, with the differences discussed below. The air vehicle **900** thus comprises fuselage **920**, and payload **960**, substantially similar to fuselage **200**, and payload **600**, respectively, as disclosed for the embodiment illustrated in Figs. 1 to 11 and alternative variations thereof, *mutatis mutandis*, for example. The air vehicle **900** further comprises wing arrangement **930**, propulsion system **940** and empennage **950** which have particular features according to another aspect of the invention which are per se novel and which may be applied, *mutatis mutandis* to other air vehicle configurations including the embodiments of Figs. 1 to 12(b).

The wing arrangement **930** of the embodiment of Figs. 13 to 15 is similar to wing arrangement **300** of the embodiment illustrated in Figs. 1 to 11, *mutatis mutandis*, and comprises a pair of wings **932**. Referring particularly to Fig. 15, each wing **932** according to this aspect of the invention is modular and comprises an outboard portion **933** and an inboard portion **931**. Inboard portion **931** is fixedly mounted to the fuselage **920** at the wing root **938**, and is configured for enabling the respective main wheels **992** of the undercarriage **991** to be mounted thereto via mounting arrangement **993**. The inboard portion **931** also comprises a support structure **970** for adjustably mounting thereto the empennage **950**, and an engine mounting **980**, as will be disclosed in greater detail below.

Outboard portion **933** comprises wing tip **939** and is configured for being reversibly mounted to the inboard portion **931** via mounting arrangement **910**, comprising a mounting strut **912** that is receivable and reversibly engageable with respect to a load-bearing beam **914** that is comprised in the inboard portion **931**. When mounted together, the inboard portion **931** and the outward portion **933** are effectively

- 39 -

joined at a mating station **915**, via mating faces **915a**, **915b** respectively provided on the inboard portion **931** and the outward portion **933**, such as to provide aerodynamic continuity between the outer skins of the inboard portion **931** and the outward portion **933**. In this embodiment, mounting arrangement **910** is configured for facilitating
5 selective mounting and dismounting of the outward portion **933** with respect to the inboard portion **931**, in particular via a ground crew, without the necessity to disassemble the outer skins of one or both portions, or without the need to return the air vehicle to the factory. Thus, outboard portion **933** is modular, and is thus easily replaceable with another outboard portion when needed or desired, for example when
10 the original outboard portion is damaged.

According to this aspect of the invention, however, the modularity of the wing arrangement **930** also allows the wing configuration to be changed as desired, for example to be optimized to fit a particular mission profile. For example, and referring to Fig. 16, a set **1000** of outer portions **933a**, **933b**, **933c**, **933d** may be provided, each
15 having substantially identical mounting strut **912** and mating face **915b** for enabling the respective outboard portion **933** to be in turn selectively engaged to or disengaged from the inboard portion **931**. Outer portion **933b** is substantially identical to outboard portion **933** of Figs. 13 to 15, and comprises control surfaces such as aileron **921** and flaps **922**. Outer portion **933a** is substantially similar to outboard portion **933b**, but
20 lacks the control surfaces. Outer portion **933c** is substantially similar to outboard portion **933a**, but has a shorter span with respect thereto, while outer portion **933d** is substantially similar to outboard portion **933a**, but has a longer span with respect thereto. Set **1000** may comprise any number of suitable wing configurations.

The modularity of the wings **930** may be further extended to include the inner
25 portions **931** in a similar manner thereto, *mutatis mutandis*, and a set of such inner portions may also be provided to enable the relative lateral spacing between the tiltable propulsion units **940a** **940b** (see below) to be changed, for example.

The modularity of the wings **930** also allow the air vehicle **900** to operated without any wings, in vectored thrust flight mode only.

30 The empennage **950** of this embodiment is similar to empennage **850** of the embodiment of Figs. 12(a), 12(b), *mutatis mutandis*, and comprises a pair of laterally spaced booms **951**, and each boom projects in an aft direction from the respective wing, generally intermediate between the respective wing root and wing tip. In this

- 40 -

embodiment, each boom is connected to the respective inboard portion 931 via said support structure 970. Fins 954 are mounted to each boom 951 at the respective boom aft end, but in upwardly projecting and mutually converging relationship, so that the respective fin tips 948 are each above and inboard with respect to the respective fin roots 942, and a horizontal stabilizer 941 is provided joining the two fin tips 948. The horizontal stabilizer 941 comprises a control surface 949 such as an elevator, though in alternative variations of this embodiment, the horizontal stabilizer 941 may instead be non-adjustable. In this embodiment the fins 954 do not comprise controllable control surfaces, but in alternative variations of the embodiment, each fin may comprise a control surface at the trailing edge thereof that operates as a rudder and/or as a vertical stabilizer in the aerodynamic flight regime of the air vehicle 900.

Referring to Figs. 15 and 15a, support structure 970 comprises a tubular load-carrying member 972 fixedly mounted to the trailing edge of the respective inboard portion 931, and a mating end 971 of the respective boom 951 that is configured for telescopically engaging with the member 972. Mating end 971 is of an axial length that enables the end 971 to be inserted into the respective member 972 to a selectively variable depth, thereby enabling the longitudinal position of the empennage, in particular the fins 954 and stabilizer 941, to be varied with respect to the position of the wings, and thus of the fuselage. Suitable fixing means are provided to selectively fix the relative position between the end 971 and the member 972 at a particular position. For example, and referring to Fig. 15a in particular, the end 971 may comprise a series of holes therethrough and in spaced arrangement along a longitudinal line, and one such hole may be aligned at a time with a corresponding hole in the member 972, and the end 971 and the member 972 secured together via for example bolts passing through the aligned holes. Such an arrangement allows the spacing of the empennage to be changed with respect to the fuselage in a stepwise manner. Alternatively, the spacing between the empennage and the fuselage or wings may be changed in a continuous manner by using a suitable clamping arrangement that clamps the end 971 to the member 972 at any desired relative position. Many other arrangements for selectively fixing the end 971 to the member 972 will be apparent to the skilled practitioner in view of the present disclosure. These examples for support structure 970 thus allow the relative spacing between the empennage and the fuselage to be changed by a ground crew, for example. Alternatively, a set of empennages may be provided, wherein such empennages each

- 41 -

has longitudinal length different from one another, so that the original empennage may be replaced on the air vehicle with a different-sized empennage to effectively change the relative spacing between the empennage and the fuselage.

In alternative variations of this embodiment, the support structure **970** may be configured for changing the relative spacing between the empennage and the fuselage in an automated manner, for example by providing a suitable actuator, such as for example a hydraulic jack, pneumatic jack, mechanical jack, electrical jack and so on, to selectively and reciprocally move the end **971** with respect to member **972**. In such embodiments, the change in the relative spacing between the empennage and the fuselage may also be carried out during aerodynamic flight of the air vehicle **900**, as well as on the ground or during hover.

It is to be noted that changing the relative spacing between the empennage and the fuselage enables the center of gravity of the air vehicle **900** to be changed. A feature of this is that payloads of widely varying weight may be carried by the air vehicle at the same position on the fuselage and/or wings, and the potential change in position of the center of gravity may be compensated by changing the relative spacing between the empennage and the fuselage, which thereby minimizes or eliminates the need to trim the air vehicle in a manner that would otherwise increases drag, and/or the need to change the thrust ratio generated by propulsion units of the propulsion system.

It is to be noted that changing the relative spacing between the empennage and the fuselage also enables the aerodynamic center of the air vehicle **900** to be selectively changed. Thus, for example, if the wings of the air vehicle are replaced with shorter or longer wings, respectively configured for providing less or more lift, the empennage may be spaced closer to or further away, respectively, to the wings, to compensate the change in lift by correspondingly varying the moment arm of the empennage. Such changes in wing lift may be provided, for example, by means of the modular wing feature of this embodiment.

The propulsion system **940** of this embodiment is similar to the propulsion system of the embodiment illustrated in Figs. 1 to 11, *mutatis mutandis*, and comprises two tiltable propulsion units **940a**, **940b** and a fixed propulsion unit **940c**. In this embodiment, the three propulsion units are propeller units, directly driven by the respective driveshaft of the respective motor **994**, though in alternative variations of this embodiment, one or more of the propulsion units **940** may be of a different

- 42 -

configuration, for example as disclosed for the embodiment illustrated in Figs. 1 to 11 and alternative variations thereof, *mutatis mutandis*. In the illustrated embodiment, the tiltable propulsion units **940a**, **940b** are pivotably mounted to the respective inboard portion **931** of the respective wing, in particular to the respective forwardly projecting engine mounting **980**, though in alternative variations of this embodiment, the tiltable propulsion units **940a**, **940b** may be pivotably mounted to the wings and/or fuselage in any suitable manner. In any case, the tiltable propulsion units **940a**, **940b** are pivotable about pivot axes X_a , X_b , respectively, in a similar manner to that of the embodiment illustrated in Figs. 1 to 11, *mutatis mutandis*, allowing the thrust vectors V_a , V_b and the thrusts T_a , T_b , respectively, generated by the tiltable propulsion units **940a**, **940b** to be selectively varied, independently of one another, in a similar manner to that of the embodiment illustrated in Figs. 1 to 11, *mutatis mutandis*.

Propulsion unit **940c** provides thrust T_c having a nominally vertical thrust vector V_c , and is mounted to the aft end of fuselage **920** via support structure **949**, which is configured for enabling the longitudinal spacing between the propulsion unit **940c** and the fuselage to be selectively varied, manually or in an automated manner, for example in a similar manner to that of the support structure **970**, *mutatis mutandis*. Thus, for example, support structure **949** comprises a tubular member **943** fixed to the aft end of the fuselage, and the propulsion unit **940c** comprises a longitudinal strut having an end **944** that is telescopically received in and reversibly engages with member **943** at any number of desired longitudinal positions (or alternatively a plurality of different-sized struts for the propulsion unit **940c** may be provided), for example as disclosed for the support structure **970**, *mutatis mutandis*. This feature can be also used to adjust the position of the center of gravity of the air vehicle **900**, together with, or instead of, the feature of the movable empennage, as discussed above.

Optionally, the propulsion unit **940c** may be removed altogether from the air vehicle **900**, enabling the air vehicle **900** to operate as a STOL vehicle or as a conventional air vehicle, rendering the air vehicle **900** even more flexible and mission adaptive. Thus, during maintenance of the aft propulsion unit **940c**, or where full VTOL capability is not required, the air vehicle **900** can still be operated by removing the propulsion unit **940c**.

In these or other alternative variations of the illustrated embodiments, the propulsion system may comprise more than three propulsion units in any suitable

- 43 -

configuration, wherein at least two such propulsion units provide a controllable thrust vector and have adjustable thrust levels, which are selectively and independently controllable for each of these propulsion units separately, and operate in a similar manner to the two forward mounted ducted fan units of the illustrated embodiments,
5 *mutatis mutandis*. For example, the propulsion system may comprise 4, 5, 6 or more propulsion units.

In these or other alternative variations of the illustrated embodiments, the propulsion system may comprise a plurality of propulsion units that are different from ducted fan units, *mutatis mutandis*, comprising, for example, turboprop units, turbofan
10 units, turbojet units, propfan (unducted fan) units, propellers (shrouded or unshrouded), and so on, or any combination thereof and/or of ducted fan units. In each case, at least two of the propulsion systems are independently controllable one from another to provide a desired thrust vector and/or a desired thrust level.

In these or other alternative variations of the illustrated embodiments, the
15 propulsion system may comprise a plurality of propulsion units, in which each propulsion unit may comprise a cluster of thrust-producing motors, for example a cluster of ducted fans.

In these or other alternative variations of the illustrated embodiments, the propulsion system may comprise a plurality of electrically powered propulsion units, in
20 which power to these propulsion units is provided from a ground power generating unit via a tether that includes at least one electrical cable. The ground unit may be static, which allows the air vehicle to be in hover or forward flight within a circuit determined by the length and flexibility of the tether. Alternatively, the ground unit may be carried on a ground vehicle, and thus allows the air vehicle to be in hover or forward flight by
25 remaining close to the ground vehicle which is also moving.

In alternative variations of the illustrated embodiments, the air vehicle may be provided without wings or empennage, and is otherwise similar to and thus operates in a similar manner to the illustrated embodiments, *mutatis mutandis*, but in vectored thrust flight mode only.

In alternative variations of the illustrated embodiments, the air vehicle may be
30 provided without a fuselage per se and optionally without empennage, and is otherwise similar to and thus operates in a similar manner to the illustrated embodiments, *mutatis mutandis*, the air vehicle being of a flying wing type of vehicle wherein the air vehicle

- 44 -

body constitutes the wings rather than a fuselage. In such applications or the invention, the propulsion units are mounted to the air vehicle body.

In the method claims that follow, alphanumeric characters and Roman numerals used to designate claim steps are provided for convenience only and do not imply any
5 particular order of performing the steps.

Finally, it should be noted that the word “comprising” as used throughout the appended claims is to be interpreted to mean “including but not limited to”.

While there has been shown and disclosed example embodiments in accordance with the invention, it will be appreciated that many changes may be made therein without
10 departing from the spirit of the invention.

CLAIMS:

1. A propulsion and control system for an air vehicle, comprising at least three propulsion units:
 - 5 wherein at least a first said propulsion unit and a second said propulsion unit are tiltable propulsion units, each said tiltable propulsion unit being configured for generating a respective thrust and for being selectively tiltable about at least one respective tilt axis to provide a respective thrust vector that is selectively variable at least between a general vertical thrust vector direction and a general longitudinal thrust vector direction with respect to the air vehicle; and
 - 10 wherein at least a third said propulsion unit is configured for generating a respective thrust having a thrust vector alignable in at least said general vertical thrust vector direction;
 - wherein said system is configured for selectively enabling said propulsion units to provide sufficient thrust to the air vehicle for vectored thrust flight when said 15 respective thrust vectors are aligned with said generally vertical thrust vector direction, and for selectively enabling said propulsion units to provide sufficient thrust to the air vehicle for aerodynamic flight when said respective variable thrust vectors are aligned with said generally longitudinal thrust vector direction, and
 - 20 wherein said system is further configured for selectively generating variable control moments for control and stability of the air vehicle including:
 - (a) controllably varying said respective thrust generated by each said propulsion unit independently of one another; and
 - (b) controllably varying said respective variable thrust vector provided by each 25 said tiltable propulsion unit independently of one another.
2. The system according to claim 1, wherein each said tiltable propulsion unit comprises any one of a tiltable ducted fan unit, a tiltable propeller unit, a tiltable turbojet unit, a tiltable turbofan unit, a tiltable propfan unit.
3. The system according to claim 2, wherein each said tiltable ducted fan unit 30 comprises at least one fan and has an absence of movable vanes for controlling the respective said variable thrust vector.

- 46 -

4. The system according to any one of claims 1 to 3, wherein said third propulsion unit is a non-tiltable propulsion unit, fixedly mountable to the air vehicle to provide a thrust having a fixed thrust vector with respect thereto.
5. The system according to claim 4, wherein said non-tiltable propulsion unit comprises any one of non-tiltable ducted fan unit, a non-tiltable propeller unit, a non-tiltable turbojet unit, a non-tiltable turbofan unit, a non-tiltable propfan unit
6. The system according to claim 5, wherein said non-tiltable ducted fan unit comprises at least one fan and has an absence of vanes for controlling the respective said vector.
- 10 7. The system according to any one of claims 1 to 3, wherein said third propulsion unit is a tiltable propulsion unit, tiltable about at least one respective tilt axis.
8. The system according to claim 7, wherein said third propulsion unit is configured for providing a respective variable thrust vector that is selectively variable at least between said general vertical thrust vector direction and said general longitudinal thrust vector direction.
- 15 9. The system according to any one of claims 1 to 8, configured to provide a said variable control moment in the form of a pitch control moment in said vectored thrust flight by varying a ratio of said respective thrusts generated by the two said tiltable propulsion units with respect to said respective thrust generated by said third propulsion unit.
- 20 10. The system according to any one of claims 1 to 9, configured to provide a said variable control moment in the form of a yaw control moment in said vectored thrust flight by suitably varying said respective thrust vectors of said tiltable propulsion units responsive to tilting said tiltable propulsion units in mutually opposite directions with respect to the respective said tilt axes.
- 25 11. The system according to any one of claims 1 to 10, configured to provide a said variable control moment in the form of a roll control moment in said vectored thrust flight by varying a ratio of said respective thrust generated by said first propulsion unit with respect to said respective thrust generated by said second propulsion unit.
- 30 12. The system of any one of claims 1 to 11, further configured to provide a generally longitudinal motion when in said vectored thrust flight by suitably varying said respective thrust vectors of said tiltable propulsion units responsive to tilting said tiltable propulsion units in mutually similar directions.

13. The system according to any one of claims 1 to 12, configured to provide a said variable control moment in the form of a yaw control moment in said aerodynamic flight by varying a ratio of the thrust generated by said first propulsion unit with respect to the thrust generated by said second propulsion unit.
- 5 14. The system according to any one of claims 1 to 13, configured to provide a said variable control moment in the form of a roll control moment in said aerodynamic flight by suitably by suitably varying said respective thrust vectors of said tiltable propulsion units responsive to tilting said tiltable propulsion units in mutually opposite directions with respect to the respective said tilt axes.
- 10 15. The system according to any one of claims 1 to 14, configured to provide a said variable control moment in the form of a pitch control moment in said aerodynamic flight by suitably varying said respective thrust vectors of said tiltable propulsion units responsive to tilting said tiltable propulsion units in mutually similar directions.
16. The system according to any one of claims 1 to 15, wherein each said tiltable
15 propulsion unit comprises a respective motor that is tiltable with the respective propulsion unit.
17. The system according to claim 16, wherein each said tiltable propulsion unit is configured for inducing a braking procedure for the respective motor while the respective tiltable propulsion unit is being tilted through a desired tilt angle to vary the
20 respective thrust vector thereof.
18. The system according to claim 16 or 17, wherein at least one said tiltable propulsion unit is a said tiltable ducted fan unit, and wherein said respective motor is accommodated in said respective tiltable ducted fan unit and configured for driving the respective said fan.
- 25 19. The system according to claim 16, wherein at least one said tiltable propulsion unit is a said tiltable propeller unit, and wherein said respective motor is configured for driving a respective propeller thereof.
20. The system according to any one of claims 1 to 19, wherein said propulsion units are configured as mutually co-rotating propulsion units.
- 30 21. An air vehicle comprising the propulsion and control system as defined in any one of claims 1 to 20, said air vehicle comprising a center of gravity and a body, said air vehicle being configured for cruising.

- 48 -

22. The air vehicle according to claim 21, wherein said first and second propulsion units are mounted to the air vehicle forward of said center of gravity of the air vehicle, and wherein said third propulsion unit is mounted aft of said center of gravity.
23. The air vehicle according to any one of claims 21 to 22, wherein said air vehicle
5 is configured for aerodynamic flight, and said body is a fuselage and comprising wings and empennage, wherein said wings and empennage are configured for providing aerodynamic lift and stability of the air vehicle in said aerodynamic flight.
24. The air vehicle according to claim 23, wherein at least one of said wings and said empennage is further configured for generating variable aerodynamic control
10 moments for control of the air vehicle in said aerodynamic flight operations.
25. The air vehicle according to any one of claims 21 to 24, wherein said propulsion and control system is further configured for selectively changing the position of said center of gravity.
26. The air vehicle according to claim 25, wherein a relative position between said
15 third propulsion unit and said tiltable propulsion units is longitudinally adjustable.
27. The air vehicle according to claim 26, wherein said third propulsion unit is mounted to an aft end of said body via a first support structure, said first support structure being configured for adjusting a longitudinal spacing between said third propulsion unit and said aft end.
- 20 28. The air vehicle according to claim 27, wherein said first support structure is configured for facilitating said adjusting, and optionally further configured for facilitating mounting and dismounting of said third propulsion unit with respect to said body by a ground crew.
29. The air vehicle according to claim 27, wherein said first support structure is
25 configured for providing said adjusting in an automated manner.
30. The air vehicle according to any one of claims 23 to 29, wherein said empennage is configured for selectively changing the position of said center of gravity and/or for changing the aerodynamic center of the air vehicle.
31. The air vehicle according to claim 28, wherein said empennage is mounted to
30 said fuselage or said wings via a second support structure, said second support structure being configured for adjusting a longitudinal spacing between said empennage and said fuselage or said wings, respectively.

32. The air vehicle according to claim 31, wherein said second support structure is configured for facilitating said adjusting, and optionally further configured for facilitating mounting and dismounting of said empennage with respect to said fuselage or wings by a ground crew.
- 5 33. The air vehicle according to claim 31, wherein said second support structure is configured for providing said adjusting in an automated manner.
34. The air vehicle according to any one of claims 23 to 33, wherein said wings are modular and selectable from a group of modular wing sets, wherein each said modular wing set is configured for being mountable in turn to said body for providing
10 aerodynamic lift in forward flight.
35. The air vehicle according to claim 34, wherein at least one said modular wing set is configured for providing said air vehicle with a performance different from that provided by another said modular wing set.
36. The air vehicle according to claim 34 or claim 35, wherein each said modular
15 wing set is configured for facilitating mounting and dismounting of the respective modular wing set to said fuselage by a ground crew.
37. A method for providing propulsion and control to an air vehicle, comprising,
(A) providing the air vehicle with at least three propulsion units, each propulsion unit being configured for providing a selectively adjustable thrust and having a
20 thrust vector at least alignable in a general vertical thrust vector direction, and wherein at least two said propulsion units are each tiltable propulsion units and further configured for enabling said respective thrust vector to be selectively variable at least between said general vertical thrust vector direction and a general longitudinal thrust vector direction with respect to the air vehicle; and
25 (B) selectively operating said propulsion units to provide sufficient thrust to the air vehicle for:
(i) vectored thrust flight, wherein said respective thrust vectors of said at least three propulsion units are aligned with said generally vertical thrust vector direction; and
30 (ii) aerodynamic flight, wherein said respective variable thrust vectors of said tiltable propulsion units are aligned with said generally longitudinal thrust vector direction;

- 50 -

(C) selectively generating variable control moments for control and stability of the air vehicle including:

- (a) controllably varying said respective thrust generated by each one of said at least three said propulsion units independently of one another;
- 5 (b) controllably varying said respective variable thrust vector provided by each said tiltable propulsion unit independently of one another.

38. Method according to claim 37, wherein said air vehicle is the air vehicle defined in any one of claims 21 to 36.

10

39. A method for operating an air vehicle, comprising:

- (a) providing an air vehicle as defined in any one of claims 21 to 36;
- (b) operating said propulsion units to generate sufficient longitudinal thrust for enabling aerodynamic flight operations;
- 15 (c) augmenting said aerodynamic control moments by operating said propulsion system for generating said variable control moments.

40. A modular air vehicle comprising:

- a body;
- 20 a propulsion system;
- a group of modular wing sets, wherein each said modular wing set is configured for being mountable in turn to said body for providing aerodynamic lift in forward flight, wherein one said modular wing set is selected from said group and selectively mounted to said body; and
- 25 an empennage.

41. The air vehicle according to claim 40, wherein at least one said modular wing set is configured for providing said air vehicle with a performance different from that provided by another said modular wing set.

42. The air vehicle according to claim 40 or claim 41, wherein each said modular wing set is configured for facilitating mounting and dismounting of the respective
30 modular wing set to said fuselage by a ground crew.

43. The air vehicle according to any one of claims 40 to 42, wherein said propulsion system is the propulsion and control system as defined in any one of claims 1 to 20.

44. A propulsion and control system for an air vehicle comprising at least three propulsion units:

wherein at least one said propulsion units is a tiltable propulsion unit, configured for generating a respective thrust and for being selectively tiltable about each one of at least two respective tilt axes to provide a first thrust vector that is selectively variable with respect to one said tilt axis at least between a general vertical thrust vector direction and a general longitudinal thrust vector direction, and to provide a second thrust vector that is selectively variable with respect to another said tilt axis; and

wherein at least two other said propulsion unit are each configured for generating a respective thrust having a respective thrust vector alignable in at least said general vertical thrust vector direction;

wherein said system is configured for selectively enabling said propulsion units to provide sufficient thrust to the air vehicle for vectored thrust flight when said respective thrust vectors are aligned with said generally vertical thrust vector direction, and for selectively enabling said at least one tiltable propulsion unit to provide sufficient thrust to the air vehicle for aerodynamic flight when said first thrust vector is aligned with said generally longitudinal thrust vector direction, and

wherein said system is further configured for selectively generating variable control moments for control and stability of the air vehicle including:

- (a) controllably and separately varying said respective thrust generated by each said propulsion unit independently of one another; and
- (b) controllably and separately varying said first thrust vector provided by said tiltable propulsion unit independently of said second thrust vector.

45. A method for providing propulsion and control to an air vehicle, comprising,

(A) providing the air vehicle with at least three propulsion units, each propulsion unit being configured for providing a selectively adjustable thrust and having a thrust vector at least alignable in a general vertical thrust vector direction, and wherein at least one said propulsion units is a tiltable propulsion unit and wherein said respective thrust vector is a first variable thrust vector configured to be selectively variable at least between said general vertical thrust vector direction and a general longitudinal thrust vector direction with respect to the air vehicle, and

wherein said tiltable propulsion unit is further configured for providing a second thrust vector that is selectively variable; and

(B) selectively operating said propulsion units to provide sufficient thrust to the air vehicle for:

5 (i) vectored thrust flight, wherein said respective thrust vectors of said at least three propulsion units are aligned with said generally vertical thrust vector direction; and

(ii) aerodynamic flight, wherein said first variable thrust vector of said tiltable propulsion unit is aligned with said generally longitudinal thrust vector
10 direction;

(C) selectively generating variable control moments for control and stability of the air vehicle including:

(a) controllably varying said respective thrust generated by each one of said at least three said propulsion units independently of one another;

15 (b) controllably varying said first variable thrust vector provided by said tiltable propulsion unit independently of second variable thrust vector.

46. A method for operating an air vehicle, said vehicle comprising at least one propulsion unit having a rotary component whereby rotation of said rotary component generates a thrust for operation of the propulsion unit, said propulsion unit being tiltable
20 between a first thrust direction and a second thrust direction, said method comprising implementing a braking procedure to said rotary component such as to stop or significantly reduce rotation thereof during at least a major portion of the tilting of said propulsion unit between said first thrust direction and said second thrust direction.

47. The method according to claim 46, wherein said first thrust direction
25 corresponds to a general horizontal thrust position and said second thrust direction corresponds to a general vertical thrust position.

48. An air vehicle comprising at least one propulsion unit having a rotary component whereby rotation of said rotary component is configured for generating a thrust for operation of the propulsion unit, said propulsion unit being tiltable between a
30 first thrust direction and a second thrust direction, and comprising a braking arrangement configured for stopping or significantly reducing rotation of said rotary component during at least a major portion of the tilting of said propulsion unit between said first thrust direction and said second thrust direction.

- 53 -

49. The air vehicle according to claim 48, wherein said first thrust direction corresponds to a general horizontal thrust position and said second thrust direction corresponds to a general vertical thrust position.

50. A propulsion unit for an air vehicle, said propulsion unit having a rotary
5 component whereby rotation of said rotary component is configured for generating a thrust for operation of the propulsion unit, said propulsion unit being tiltable between a first thrust direction and a second thrust direction, and comprising a braking arrangement configured for stopping or significantly reducing rotation of said rotary component during at least a major portion of the tilting of said propulsion unit between
10 said first thrust direction and said second thrust direction.

51. The propulsion unit according to claim 50, wherein said first thrust direction corresponds to a general horizontal thrust position and said second thrust direction corresponds to a general vertical thrust position.

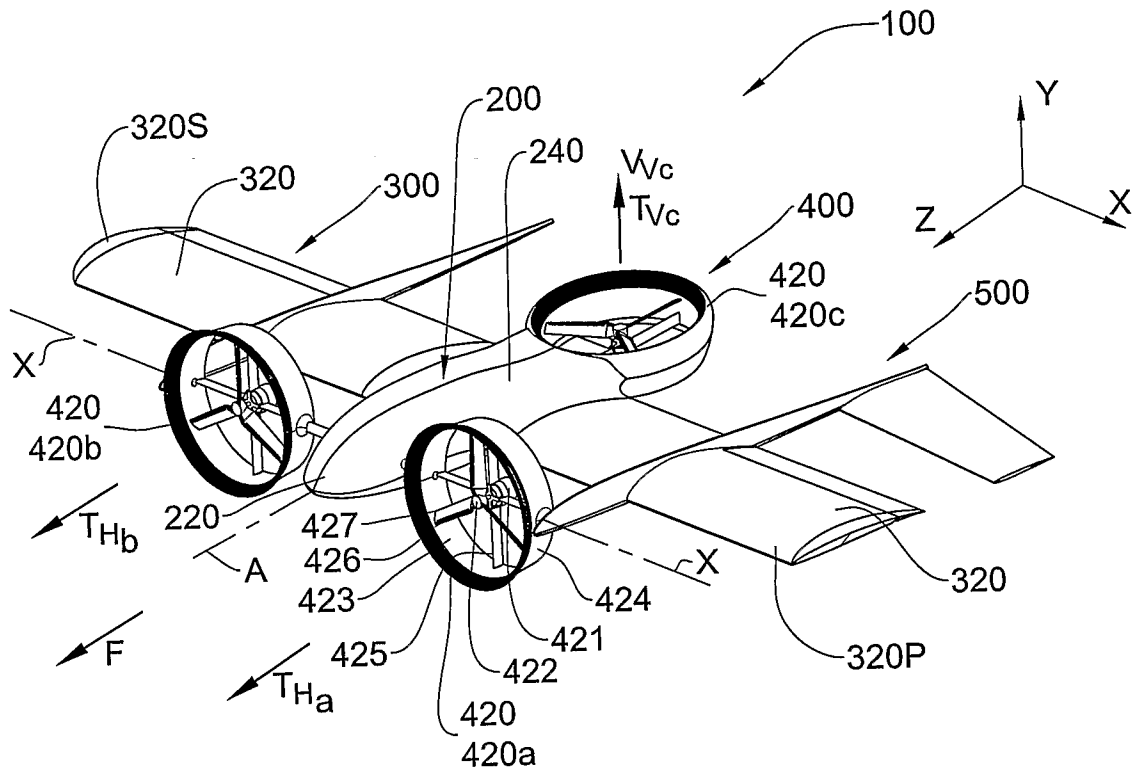

FIG. 1

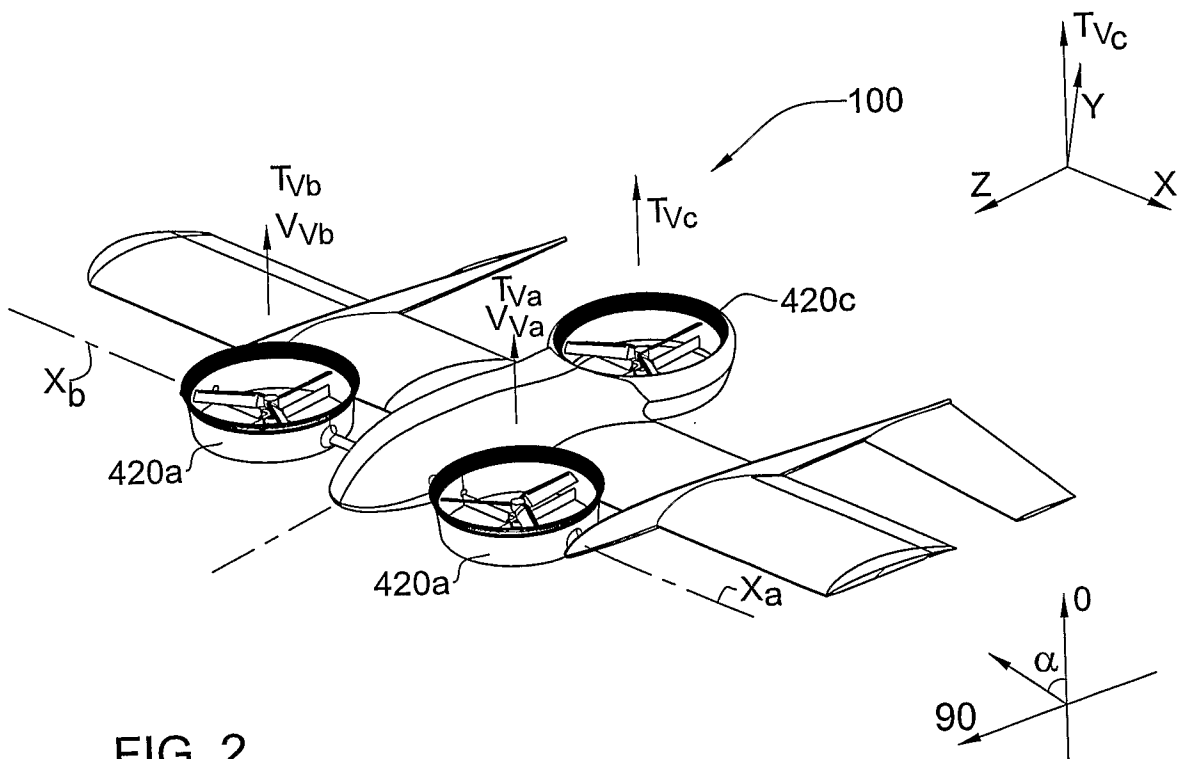

FIG. 2

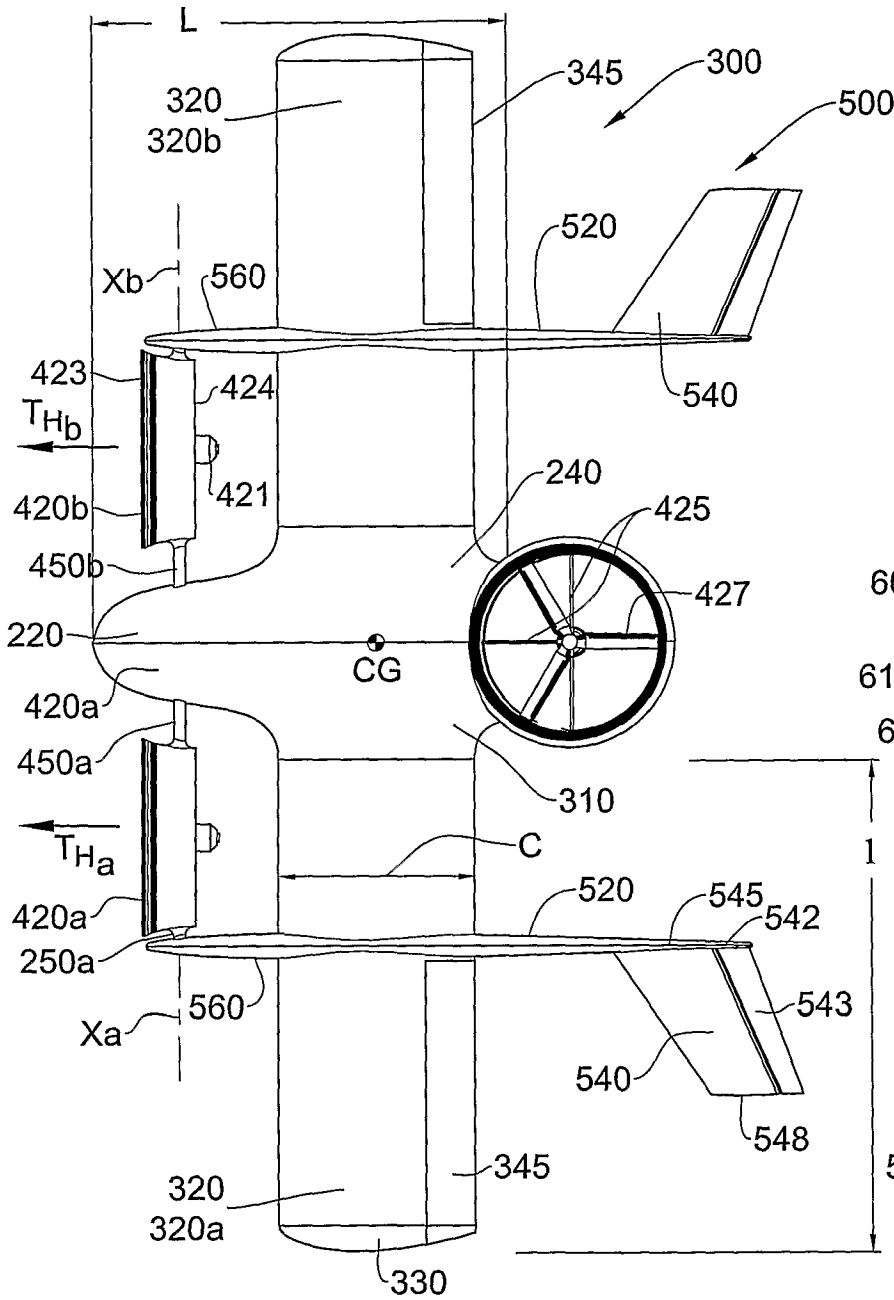

FIG. 3(a)

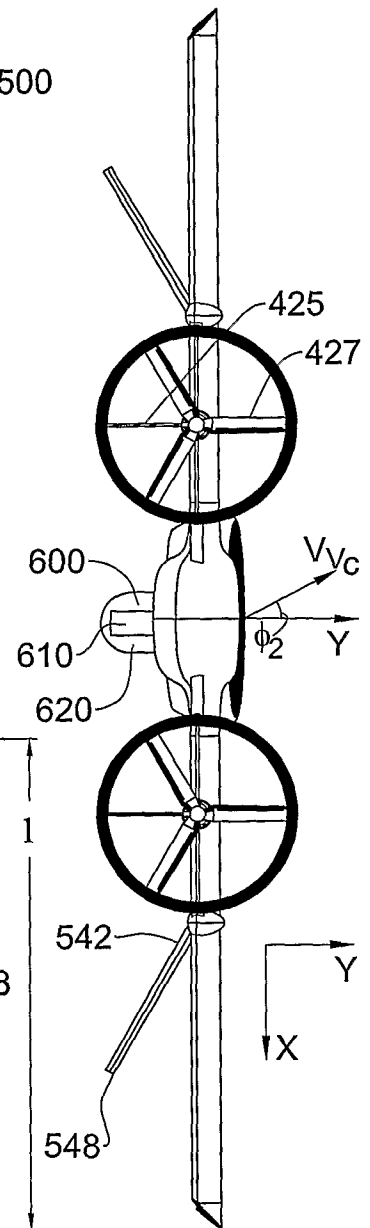

FIG. 3(b)

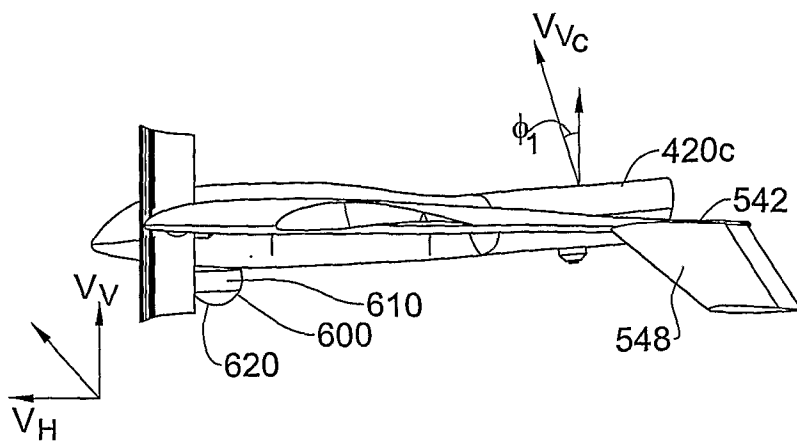

FIG. 3(c)

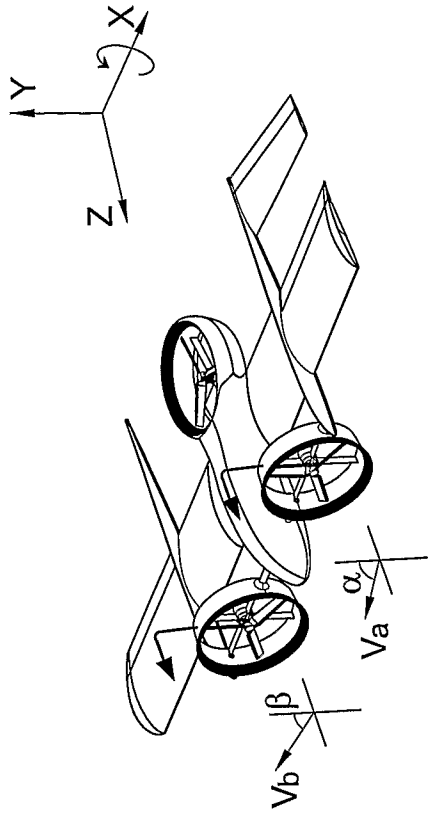

FIG. 6

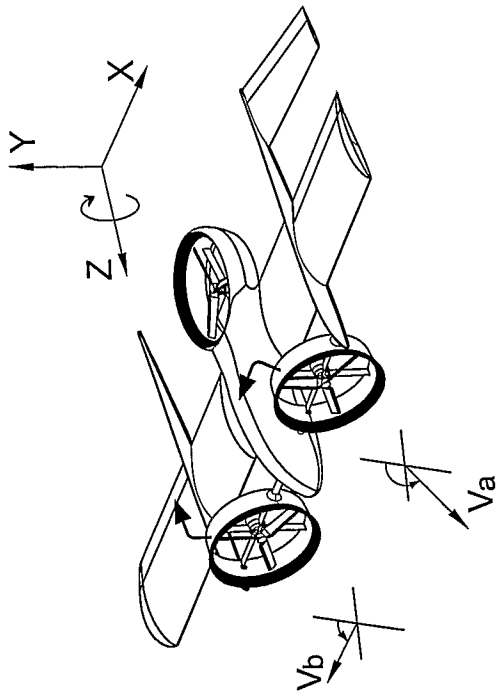

FIG. 4

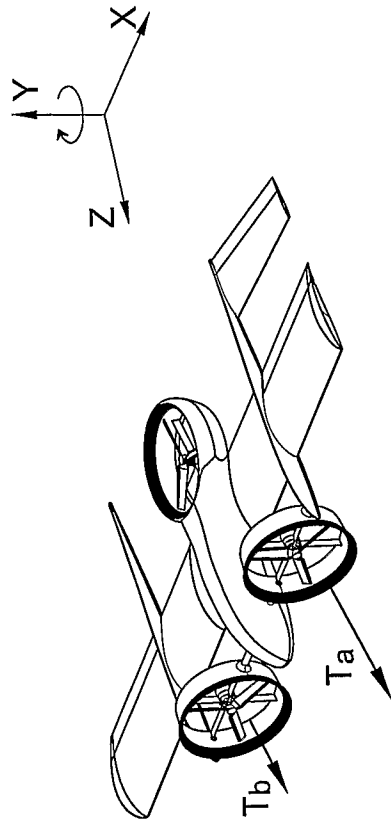

FIG. 5

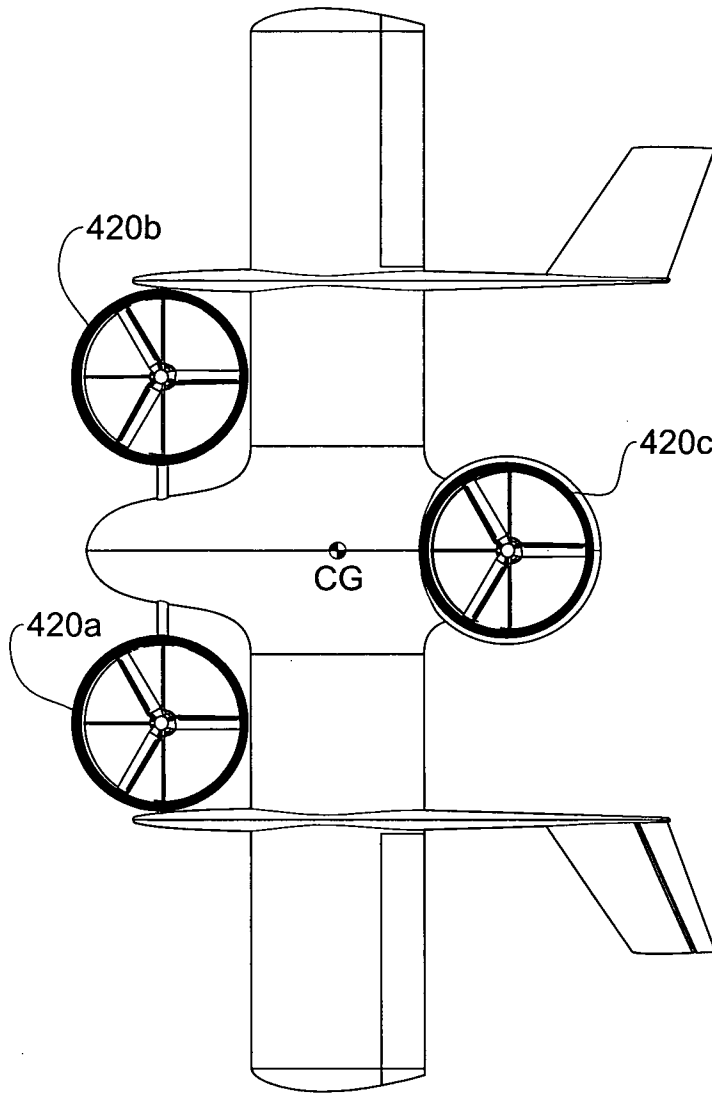

FIG. 7(a)

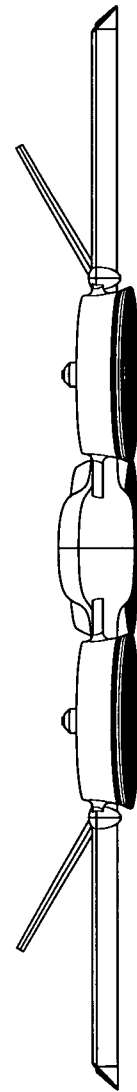

FIG. 7(b)

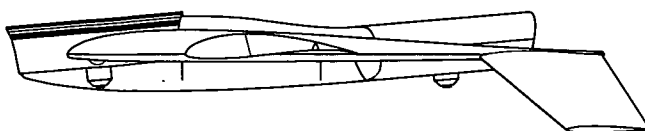

FIG. 7(c)

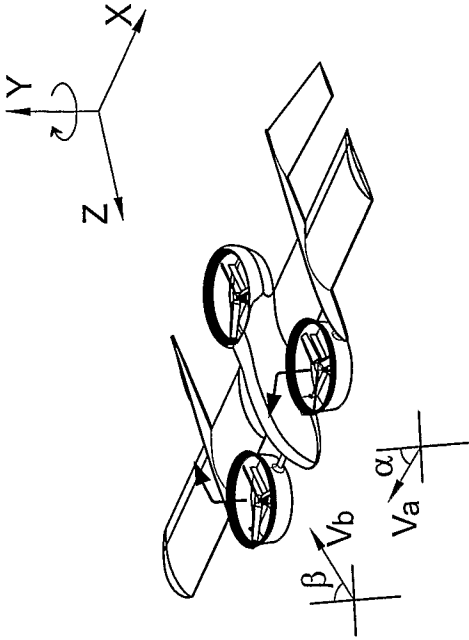

FIG. 9

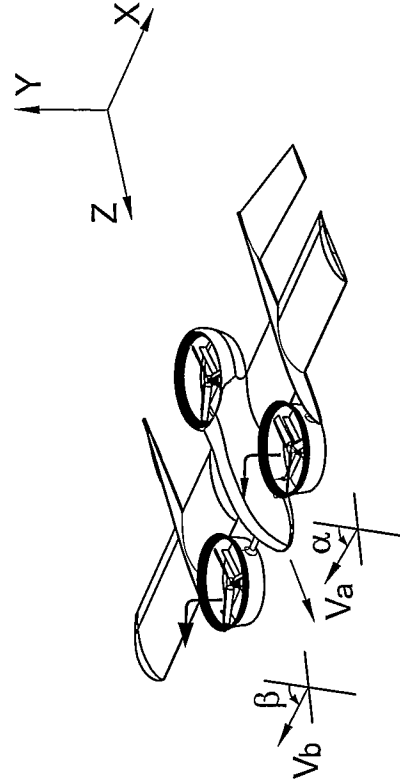

FIG. 11

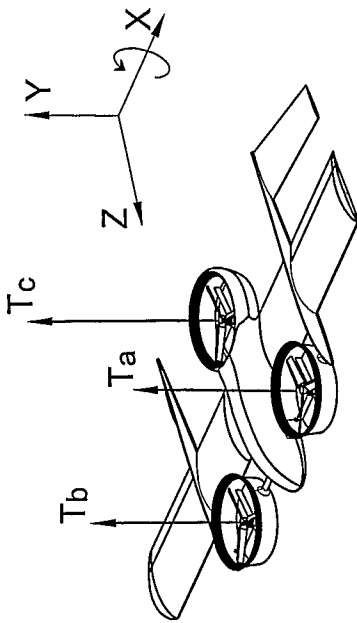

FIG. 8

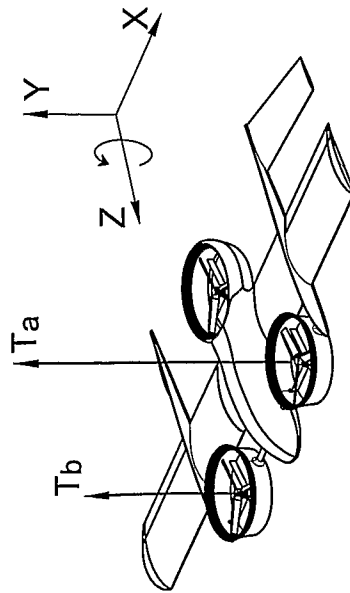

FIG. 10

6/9

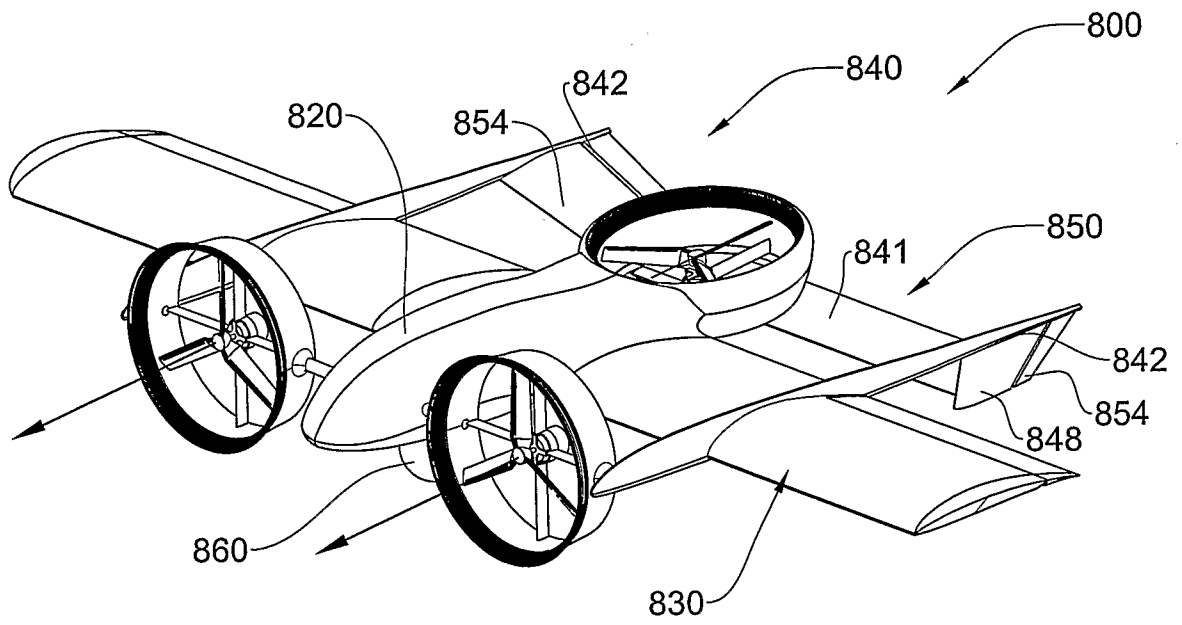

FIG. 12(a)

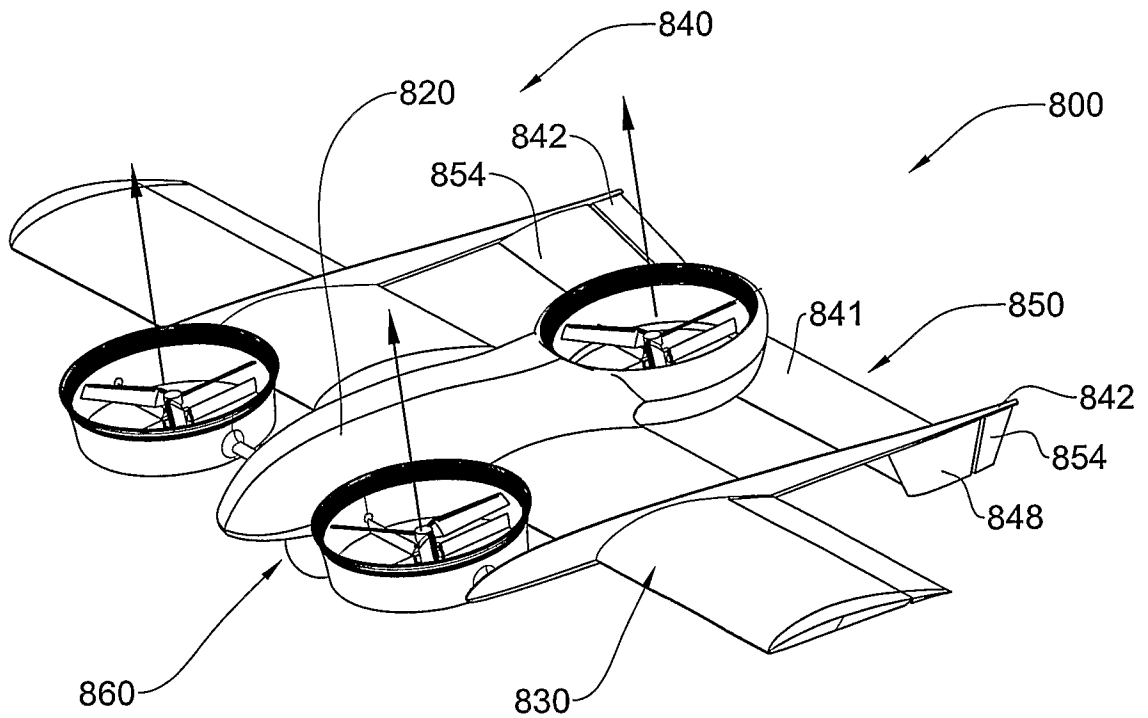

FIG. 12(b)

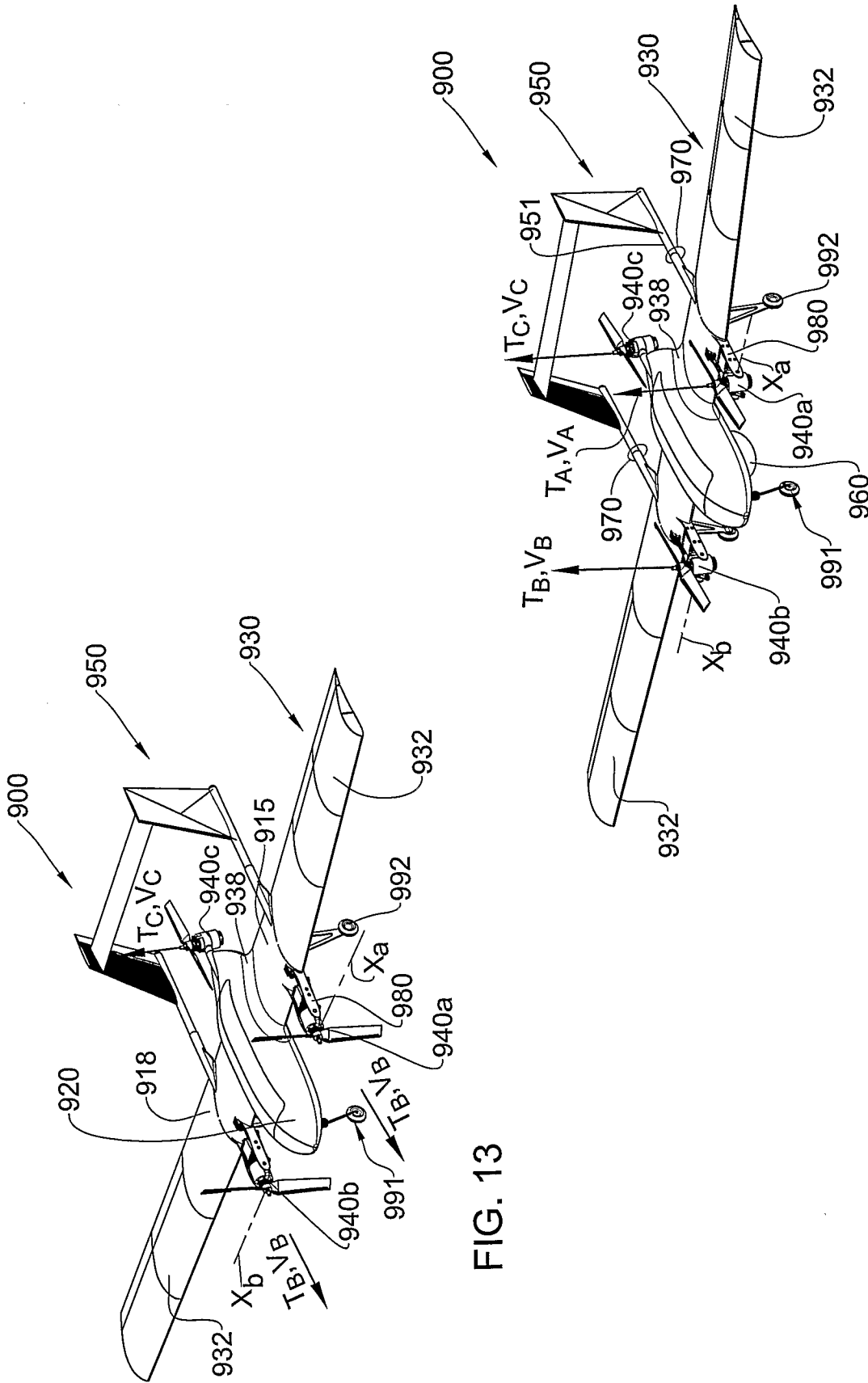

FIG. 13

FIG. 14

8/9

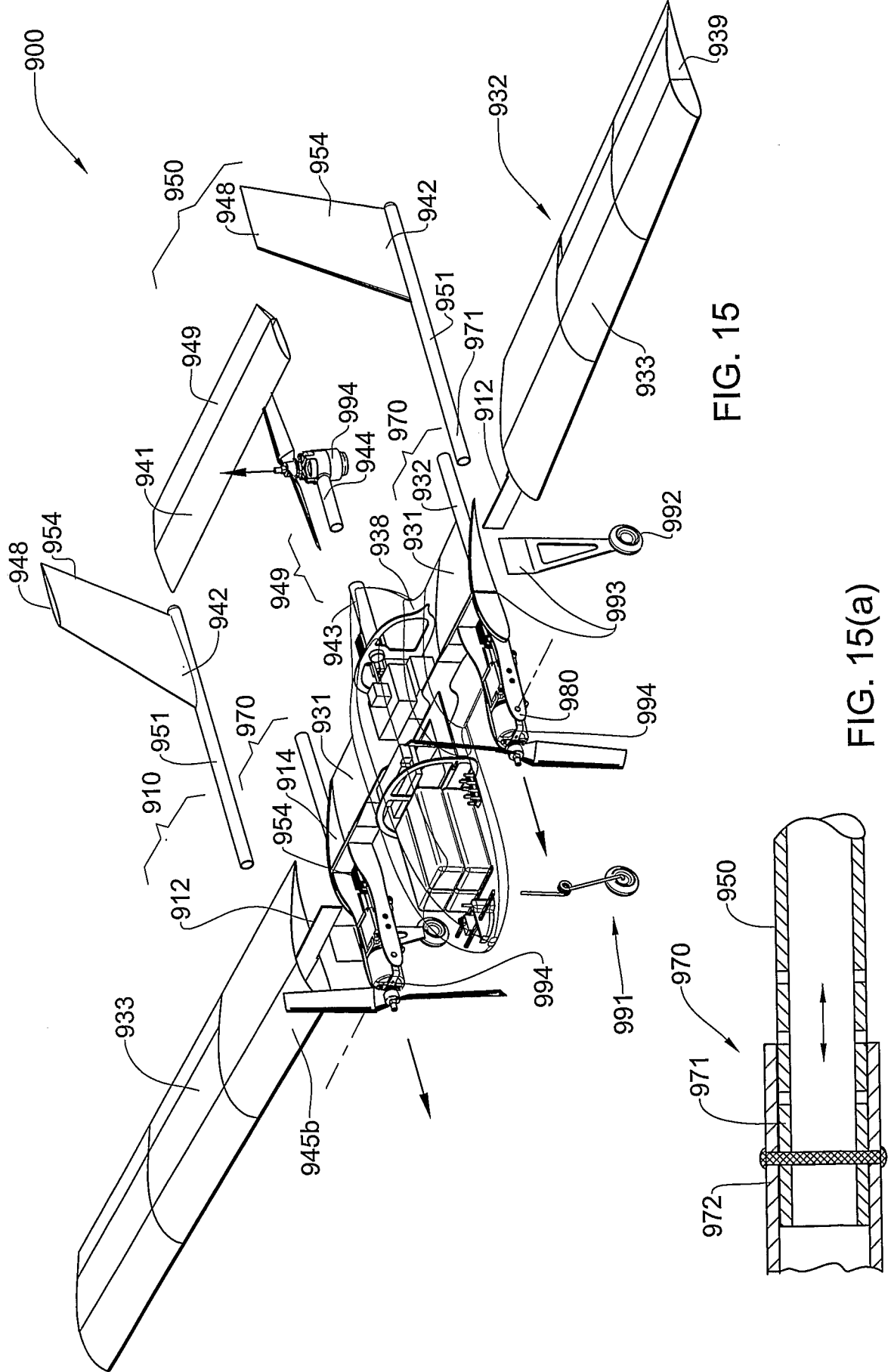

FIG. 15

FIG. 15(a)

9/9

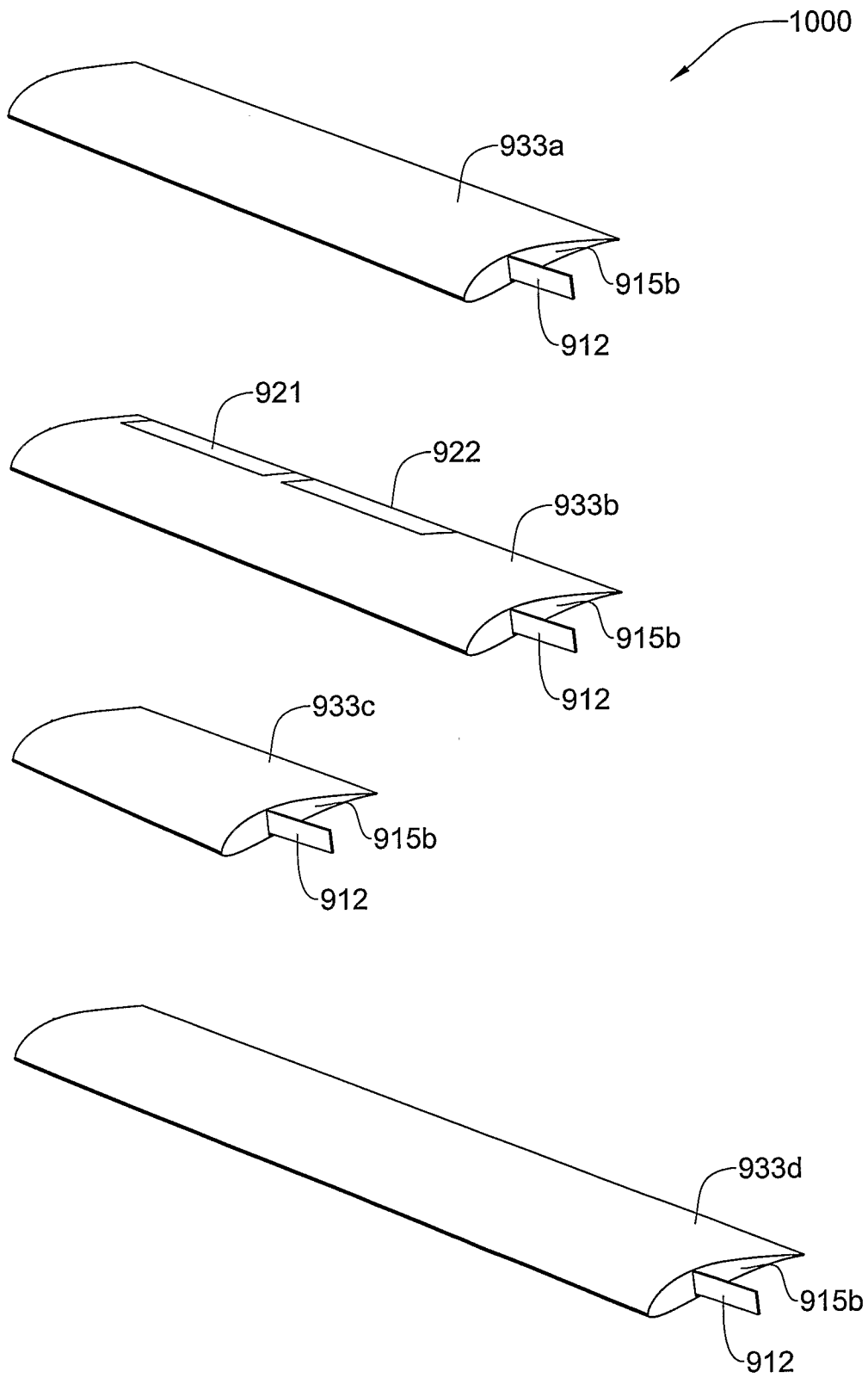

FIG. 16