

(No Model.)

3 Sheets—Sheet 2.

F. DARKIN.
Steam Engine.

No. 243,112.

Patented June 21, 1881.

Fig. 5.

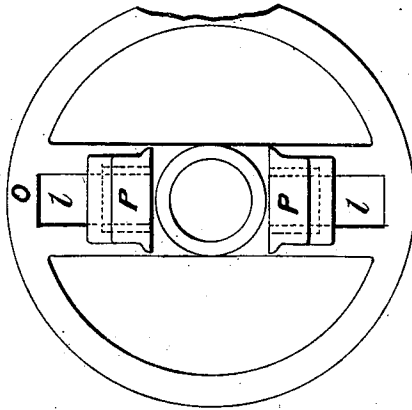

Fig. 4.

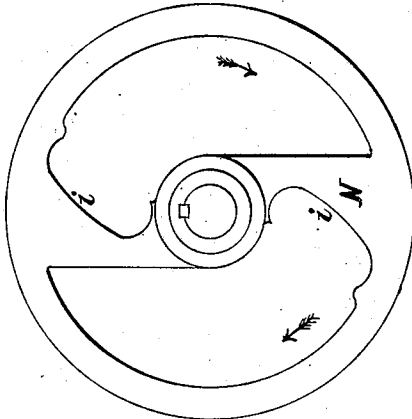
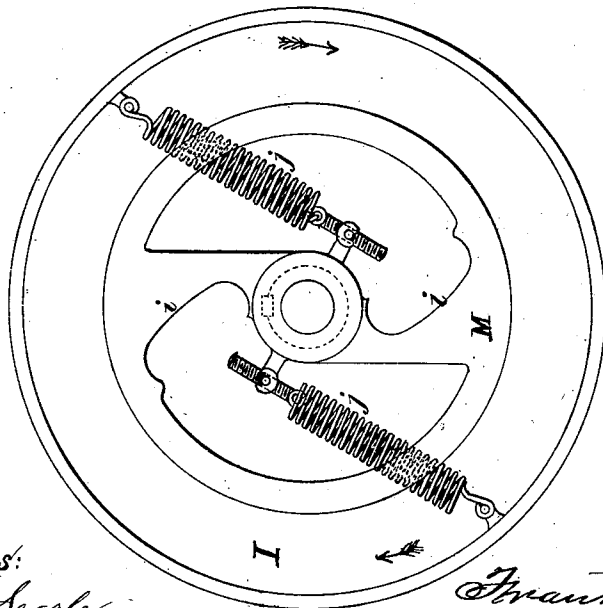

Fig. 3.



Witnesses:
Charles R. Searle,
Chas. J. Morgan.

Inventor:
Frank Darkin,
By A. O. Hayer,
Attorney.

(No Model.)

3 Sheets—Sheet 3.

F. DARKIN.
Steam Engine.

No. 243,112.

Patented June 21, 1881.

Fig. 7.

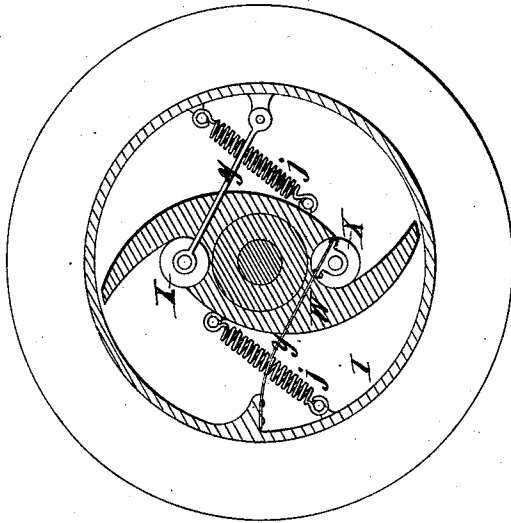
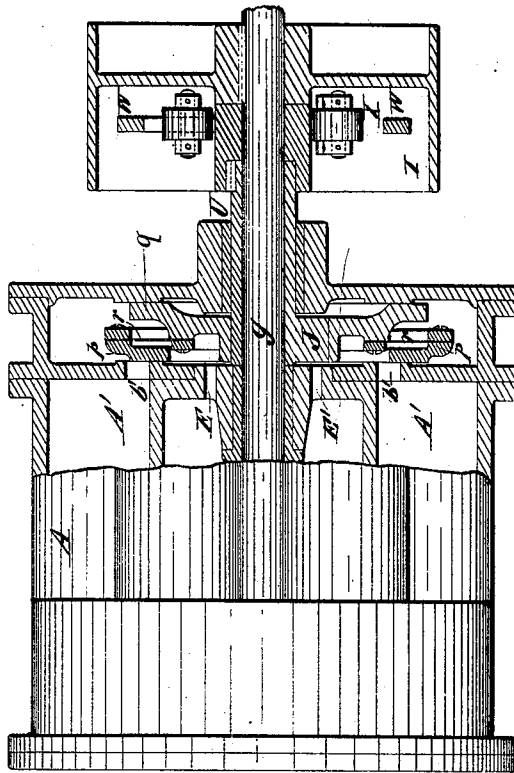

Fig. 6.



Witnesses:
Charles R. Searle,

W. J. Morgan.

Inventor:
Frank D. Darkin,

By *A. P. Thayer*
Attorney.

UNITED STATES PATENT OFFICE.

FRANK DARKIN, OF NEW YORK, N. Y.

STEAM-ENGINE.

SPECIFICATION forming part of Letters Patent No. 243,112, dated June 21, 1881.

Application filed November 4, 1880. (No model.)

To all whom it may concern:

Be it known that I, FRANK DARKIN, of New York, in the county and State of New York, have invented a new and useful Improvement in Engines Driven by Steam or other Elastic Fluid, of which the following is a specification.

My invention has reference to an engine known as "West's six-cylinder engine," for which Letters Patent were granted in the United States of America on the 29th day of June, in the year 1875, No. 165,139, entitled "improvements in steam-engines;" but part of my invention is also applicable to certain other engines, and I do not, therefore, confine my claims for such parts to the engine above specified. I propose to compound the above-mentioned engine, and also to improve the character of the valve and the method of governing the engine.

The West engine consists of a number of cylinders (preferably six) contained in one shell, and arranged in a circle around the driving-shaft. The cylinders are open at one end and terminate at the other in a plate of metal, the opposite side of which forms the port-face common to all the cylinders. The ports are simply slots or openings through this plate of metal. The pistons are in the form of rams or plungers, and when driven home completely fill up the cylinders. The ends which protrude from the open ends of the cylinders terminate in blunt conical points, which bear against the surface of a disk, near its periphery, which disk is supported at its center by a ball-and-socket joint, and is also sustained in rolling contact with a conical bearing-surface surrounding this joint. In the center of the disk is a short rod or crank-pin, which is caused by the rolling motion of the disk to describe a cone, and communicate a rotary motion by means of the crank to the driving-shaft. The shaft passes through the center of the plate of metal forming the port-face; and the steam admission is controlled by means of a valve in the form of a ring, and mounted on an eccentric carried on the shaft. The ring works steam-tight between the port-face and the inner surface of the steam-chest cover.

My improvements are as follows: I propose to make three of the six cylinders forming the West engine of smaller diameter than the other

three, the large and small cylinders being arranged alternately in a circle, the ports of the smaller or high-pressure cylinders forming an outer or larger circle on the port-face, and the ports of the larger or expansion-cylinders forming an inner and smaller circle.

The valve I propose to use will consist of a ring with a circle of holes near its outer edge, and an annular passage open to the port-face between the circle of holes and the inner edge of the valve. Steam will be first admitted through the holes to the smaller or high-pressure cylinder, from which it will be discharged, by means of the annular passage above mentioned, into the opposite low-pressure or expansion cylinder, from which it will escape, passing the inner edge of the valve to the exhaust-chamber, and thence either to the condenser or atmosphere.

At the back of the main valve above described I propose to employ a cut-off or expansion valve, and to insert between the two valves a loose flat ring, which is prevented from revolving by suitable fixtures, but is free to follow up the valves as it wears away. In this ring I cut ports corresponding to and opposite to the high-pressure ports in the port-face. The steam has to enter by these ports before reaching the holes in the main valve. The object of using this ring or intermediate port-face is to insure a perfect or absolute cut-off, which would not be the case if the cut-off valve worked direct over the holes in the main valve. The expansion-valve is actuated by a second eccentric, carried loosely on the shaft, and having an elongated sleeve projecting through the cover and connected with the governor. The two valves are kept down to the port-faces and rendered steam-tight by means of a ring, which being fastened by a flexible diaphragm to a projecting circular flange on the inner surface of the steam-chest cover, the pressure of the steam on the annular diaphragm and ring keeps the valves under them in close contact with the port-faces. Springs may be used to assist the steam in keeping the ring in position and maintaining the contact of the valves with their faces.

The governor or controlling apparatus is carried on the shaft and consists of three principal parts—viz., two plates or disks, in which

are cut right and left handed curves or guides, acting as cams, and another plate or disk with two or more slotted guides or slides on opposite sides of the center, in which are fitted
5 sliding weights, each with a stud carrying a pair of rollers. One of the first-mentioned disks or plates is fixed to the sleeve of the eccentric of the expansion or cut-off valve, and the other is attached to the shaft, so that a
10 pair of right and left handed cams cross or intersect one another like the jaws of curved shears on two opposite sides of the shaft.

The plate carrying the weights and rollers is mounted loosely on the shaft in front of the
15 two disks, and the studs, with the rollers, are grasped by the cams at the point of intersection. Springs are employed which act upon the plates in such a manner as to draw the
20 cams so that the point of intersection has a constant inclination toward the center, and thus the tendency of the weights to fly out by centrifugal force is counteracted by the shearing action of the cams, drawn together by the
25 springs. When the point of intersection is nearest the center, and the weights are close to the shaft, the main valve and cut-off valve are concentric, or nearly so; but in proportion as the speed of the engine increases, and the weights are thrown out by centrifugal force,
30 the cut-off valve is thrown farther in advance of the main valve, and steam is cut off proportionately sooner. I propose to employ in the compound engine suitable grooves and openings, to enable me, if necessary, to admit
35 high-pressure steam direct to the low-pressure or expansion cylinders, to obviate any difficulty in starting the engine.

The accompanying drawings illustrate more fully my improvements on the West six-cylinder engine.

Figure 1 is a longitudinal section of the engine, showing my method of compounding my improved cut-off valve with flexible diaphragm attachments, and my direct-acting cut-off governor and its connection with the valve. Fig.
45 2 is a sectional view of the main valve on line $x x$, showing the port-face and the positions of the ports to the high and low pressure cylinders, the cylinders being indicated by dotted lines. The shaded portions represent
50 the face of the main valve in contact with the port-face, the arrows indicating the passage of the steam through the channel c from the high to the low pressure or expansion
55 cylinder. Figs. 3, 4, and 5 represent the plates or disks of the governor in detail. Figs. 6 and 7 show a modified form of my flexible valve and cam and roller governor as applied to the smaller sizes of the West engine in its
60 simple form.

A represents the shell, in which the six cylinders are arranged around the center in a circle and parallel thereto, as in the West engine, but which I make in alternate small and
65 large sizes, A' and B' , for compounding the engine.

A^2 represents the small pistons, and B^2 the

large ones, corresponding to the cylinders and acting on the disk a , mounted upon the head
70 d of the shell by the ball and socket e , and carrying the crank-pin f , which turns the shaft g by the crank h .

a' represents the main port-face, in which are the ports b' for the smaller cylinders in a large circle, and the ports b^2 for the large cylinders in a smaller circle. This port-face is
75 formed on the case-head e' , in which the holes E' are arranged in a still smaller circle for the escape of the exhaust-steam into the cavity E^2 , from which it is discharged by a pipe suitably attached.

E represents the main valve, having the holes L , for admitting steam to the ports b' of the smaller cylinders A' , and the cored annular channel c , through which the steam exhausts
85 from cylinder A' , and passes into the larger ones B' through the ports b^2 . This valve is mounted on the eccentric e' , which is keyed fast to the shaft g . As shown in the drawings, steam is passing from the high-pressure
90 cylinder A' by means of the cored annular channel c in the main valve to the low-pressure or expansion cylinder B' , from which it will be subsequently discharged, passing the inside edge of the valve into the space D , and
95 thence by means of the holes E' into the body of the engine, carrying the lubrication to all the working parts, and finally escaping by the exhaust-pipe to the condenser or atmosphere.

F is the intermediate ring or port-face, in
100 which there are three ports, K , corresponding to and opposite the ports of the high-pressure cylinders.

G is the cut-off or expansion valve, driven by the eccentric H , and under the control of the
105 governor. This valve regulates the steam admission by the ports K in the intermediate port-face through the holes L in the main valve to the high-pressure cylinders A' .

Q represents the ring for pressing the valves
110 against the port-faces. It is connected by a flexible diaphragm, R , with an annular flange, S , of the steam-chest cover, so as to be capable of slight movement toward and from the valves, and springs T are employed to press the ring
115 on the valves and keep them in position when steam is not on. This diaphragm cuts off communication between the live steam and the exhaust through spaces D' D and the joints of the valves and eccentrics, and thus takes the
120 place of packing and avoids the friction of it. These diaphragms may be corrugated, as in Fig. 1, or plain, as in Fig. 6.

The governor consists of three plates or disks, M , N , and O , which are shown in detail in Figs.
125 3, 4, and 5. The plate M , which is loose on the shaft, but is keyed to the sleeve H , has two left-handed curves or cams, i , (seen in Fig. 3,) and has attached to it springs j , either coiled or otherwise, and connected to driving-pulley
130 I , the tendency of which springs is to prevent it from revolving in advance of the plate N , or the pulley which surrounds it. The plate N is of the same form as the one last described; but

the curves or cams *i* are right-handed—that is to say, the reverse of the others—and it is fixed on the driving - shaft. The plate O is carried loosely on the shaft or on the hub of the plate N. In it are cut slots or guides *l*, in which are carried the flanged weights P, to which are fixed studs *m* and rollers *n*, projecting between and bearing against the cams in plates M and N. The tendency of these weights and rollers, when thrown out by centrifugal force, is to increase the angular velocity of the plate M, and to cause it to revolve in advance of the plate N, thus throwing the cut-off valve G more or less in advance of the main valve, and regulating the steam admission in proportion to the variations of load on the engine. The action of the weights and rollers is counteracted by the springs above mentioned, which may be assisted, in the case of high speeds, by auxiliary springs fixed directly to the weights P P.

In the modified arrangement of Figs. 6 and 7, I show a simple double-flanged valve, the two flanges *p* and *q* being connected by a flexible steam-tight diaphragm, *r*, and driven by one eccentric, J, the latter being connected by a sleeve, U, with the governor. I construct the latter with but one cam disk or plate, W, loose on the shaft, but keyed to the eccentric-sleeve. This cam is fitted with springs *j*, as described in the case of the plate M in Fig. 3. The cam is actuated by weights in the form of rollers X, which are attached to forked levers or strips *y*, of suitable flexible metal, carried inside the driving-pulley, the action being substantially the same as that of the more elaborate governor, already described, with the exception that the engine is controlled by a single valve, the tendency to increase speed being checked by excessive and variable lead and exhaust compression. By this method of checking the speed the rattling noise is prevented which this kind of engine is subject to when the governor acts by throttling or shutting off the steam, owing to the connection of the pistons with the disk by bearing contact only.

Having thus described my invention, what I claim, and desire to secure by Letters Patent, is—

1. In an engine consisting of the circular series of cylinders, pistons, disk, port-face, and valve, substantially as herein described, the said cylinders arranged in the alternate high and low pressure order, and the said valve constructed and arranged with said port-face and cylinders, to distribute the steam to both the high and low pressure cylinders, substantially as specified.

2. The combination of valve E, having passages L, and annular chamber *c*, port-faces *a'*, with ports *b'* and *b''* in different circles, and a circular series of alternate high and low pressure cylinders, A' and B', substantially as specified.

3. The combination of intermediate port-face, F, and expansion or cut-off valve G, with main valve E, and a series of cylinders arranged in a circle, as described.

4. The combination, with a circular series of cylinders and port-face, substantially as herein described, of a circular valve operated by an eccentric in its center, and a flexible diaphragm to press the valve on the face and cut off communication between the live and exhaust steam, substantially as specified.

5. The combination, with a circular series of steam - cylinders, port - face, and a valve, substantially as herein described, of a governor consisting of centrifugal weights and cams, along which said weights roll to actuate the valve, also retracting-springs, substantially as specified.

6. In an engine consisting of a circular series of cylinders, with pistons acting on a disk by bearing contact only, and a valve common to all the cylinders, the combination, with said valve, of a governor that advances the valve and controls the speed by excessive and variable lead and exhaust compression, substantially as specified.

FRANK DARKIN.

Witnesses:

W. J. MORGAN,
F. A. THAYER.