



US00RE44284E

(19) **United States**
(12) **Reissued Patent**
Lee et al.

(10) **Patent Number:** **US RE44,284 E**
(45) **Date of Reissued Patent:** **Jun. 11, 2013**

(54) **CELL SEARCH SYSTEM FOR MOBILE STATION IN TIME DIVISION DUPLEX SYSTEM AND METHOD FOR THE SAME**

(75) Inventors: **Yu-Ro Lee**, Daejon (KR); **Dong-Seung Kwon**, Daejon (KR)

(73) Assignee: **Electronics and Telecommunications Research Institute**, Daejeon (KR)

(21) Appl. No.: **12/692,373**

(22) Filed: **Jan. 22, 2010**

Related U.S. Patent Documents

Reissue of:

(64) Patent No.: **7,321,584**
Issued: **Jan. 22, 2008**
Appl. No.: **10/256,935**
Filed: **Sep. 27, 2002**

(30) **Foreign Application Priority Data**

Oct. 25, 2001 (KR) 2001-0065989

(51) **Int. Cl.**
H04J 3/06 (2006.01)

(52) **U.S. Cl.**
USPC **370/350; 370/509; 455/525**

(58) **Field of Classification Search**
USPC 370/209, 324, 335, 337, 342, 350, 370/503, 507, 509, 510-514; 455/501, 502, 455/525; 375/145, 149, 356, 365-368
See application file for complete search history.

(56) **References Cited**

U.S. PATENT DOCUMENTS

7,076,262	B1 *	7/2006	Bhatoolaul et al.	455/522
7,102,994	B2 *	9/2006	Sezgin et al.	370/209
7,158,505	B2 *	1/2007	Dick et al.	370/350
7,248,621	B2 *	7/2007	Rudolf	375/145
2002/0057664	A1 *	5/2002	Sarkar	370/342

FOREIGN PATENT DOCUMENTS

EP	1 154 662 A1	11/2001
JP	10-126380	5/1998
JP	2001-160798	6/2001
WO	1020000067168	11/2000
WO	WO 0067396	11/2000
WO	WO 00/74276	12/2000
WO	WO 01/015696	1/2001

OTHER PUBLICATIONS

Universal Mobile Telecommunications System (UMTS), Physical Layer Procedures (TDD), 3GPP TS 25.224 version 4.1.0 Release Jul. 4, 2001.*
2000, IEEE, Design of Cyclically Permutable Codes for PN Code Acquisition in WCDMA TDD Mode, pp. 581-587.
2000 IEEE, Experimental Evaluation of 3-Step Cell Search Method in W-CDMA Mobile Radio, pp. 303-307.

* cited by examiner

Primary Examiner — Habte Mered

(74) *Attorney, Agent, or Firm* — NSIP Law

(57) **ABSTRACT**

A cell search system for a mobile station in a time division duplex system includes: a primary synchronization code search module for searching primary synchronization codes and comparing frame values of the primary synchronization codes to determine a position of the maximum value; a correlation module for estimating a phase value and acquiring a first correlation value; a secondary synchronization code search module for generating determinative variables and storing them based on the position of the maximum value; a comparison and decision module for detecting a maximum value of the determinative variables, comparing it with the values stored in the secondary synchronization code search module to count matching values, and comparing the count value with a system value to decide whether slot synchronization and group acquisition is successful; and a base station determination module for determining a second correlation value between midamble codes and the received signals, and selecting a maximum value of it to determine a base station.

31 Claims, 5 Drawing Sheets

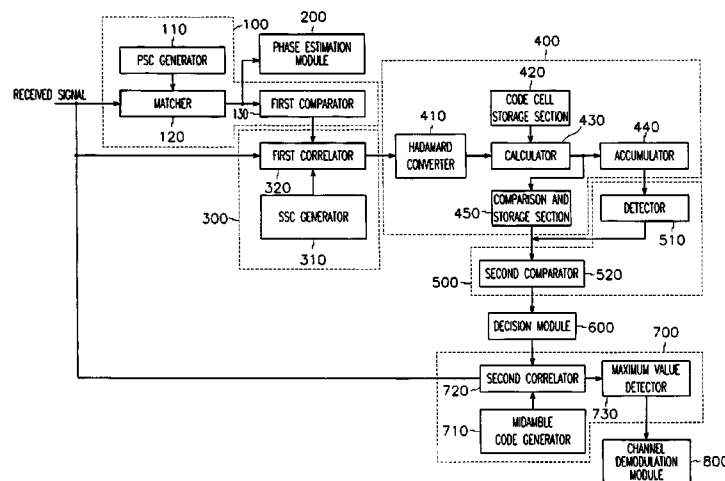
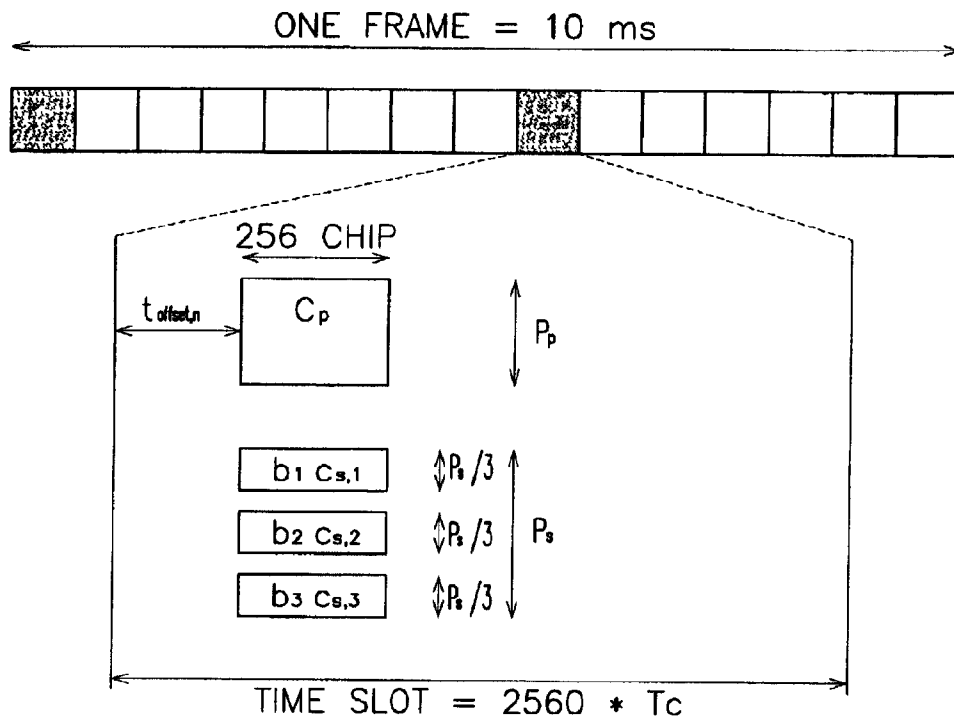
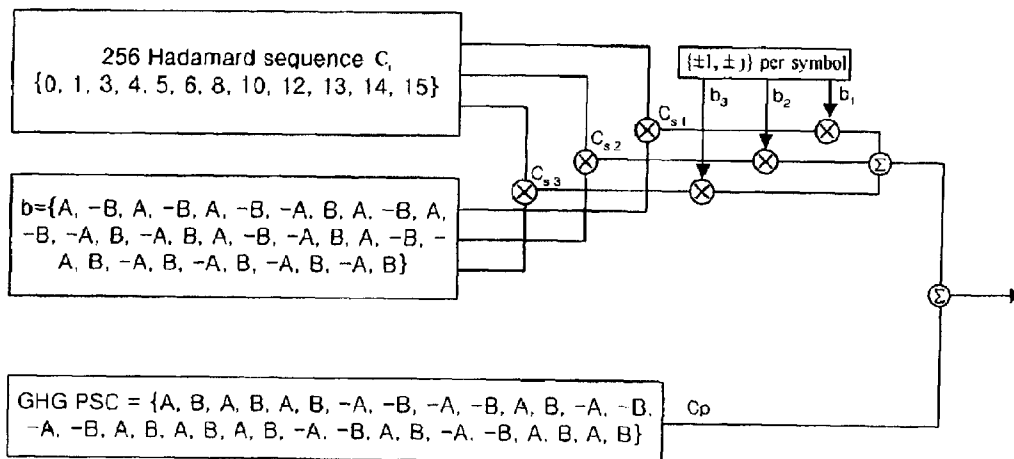

FIG. 1



$$b_i \in \{\pm 1, \pm j\}, C_{s,i} \in \{C_0, C_1, C_3, C_4, C_5, C_6, C_8, C_{10}, C_{12}, C_{13}, C_{14}, C_{15}\}, i=1,2,3$$

FIG. 2



$A = \{1, 1, 1, 1, 1, 1, -1, -1\}, B = \{1, -1, 1, -1, 1, -1, -1, 1\}$

FIG. 3

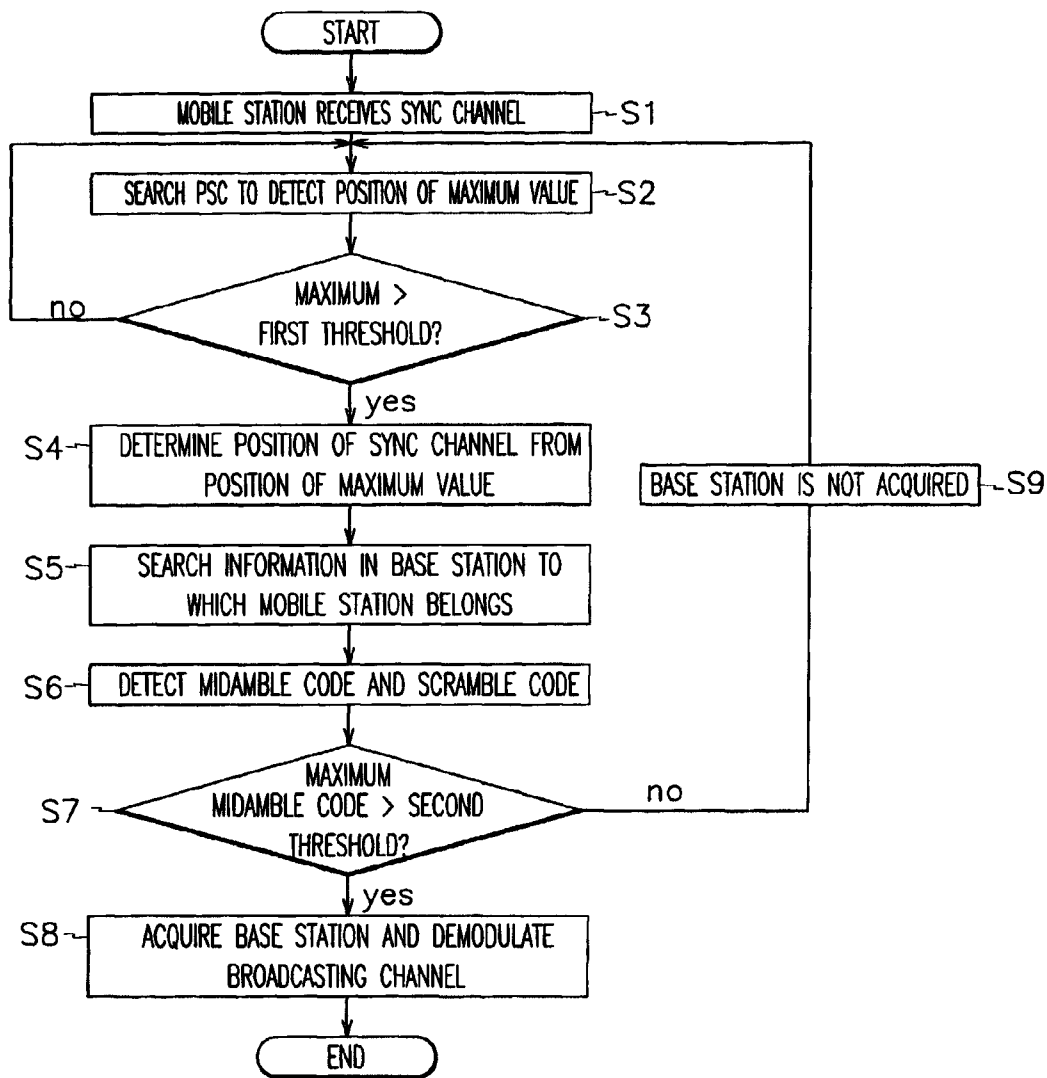

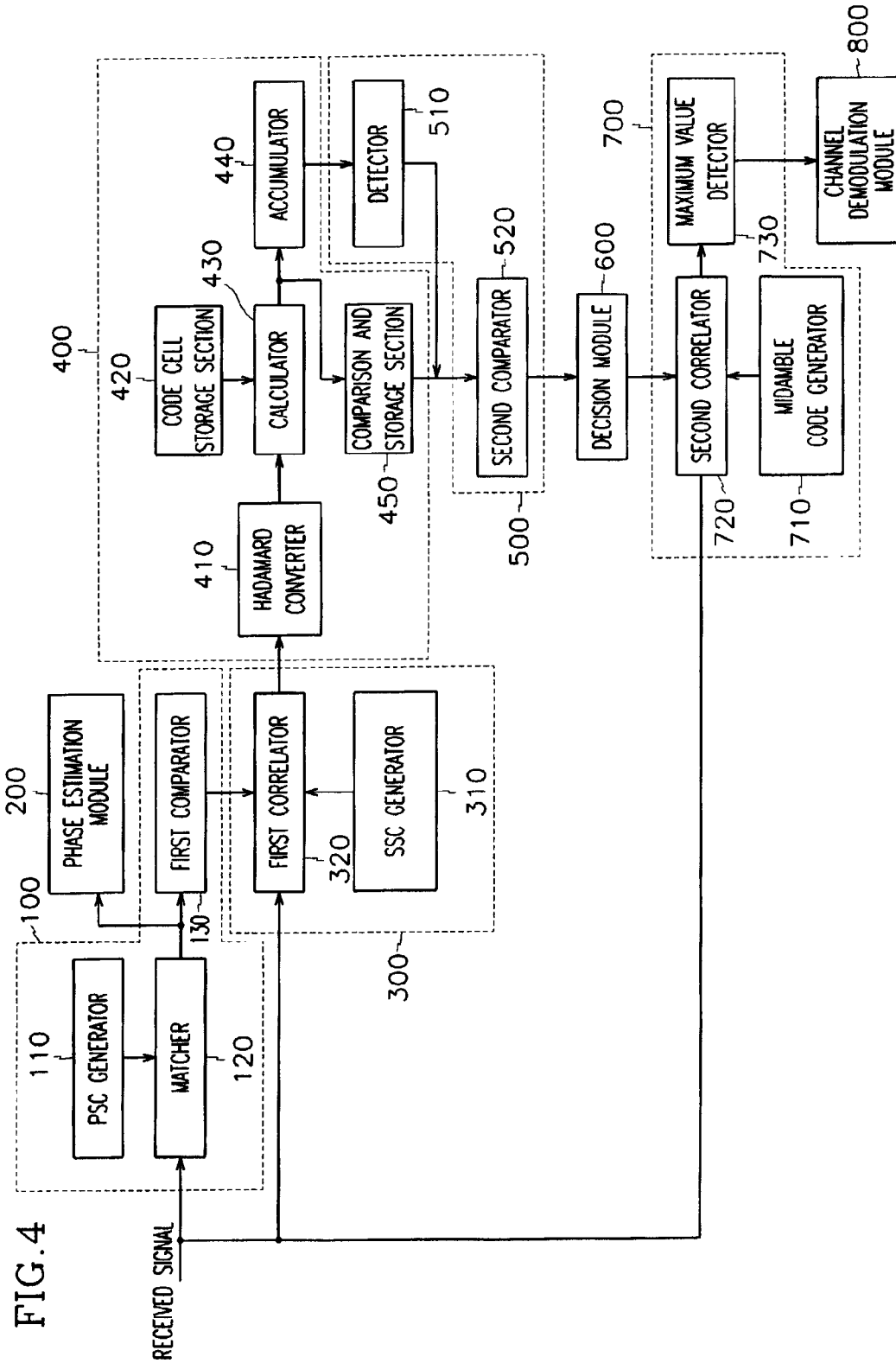
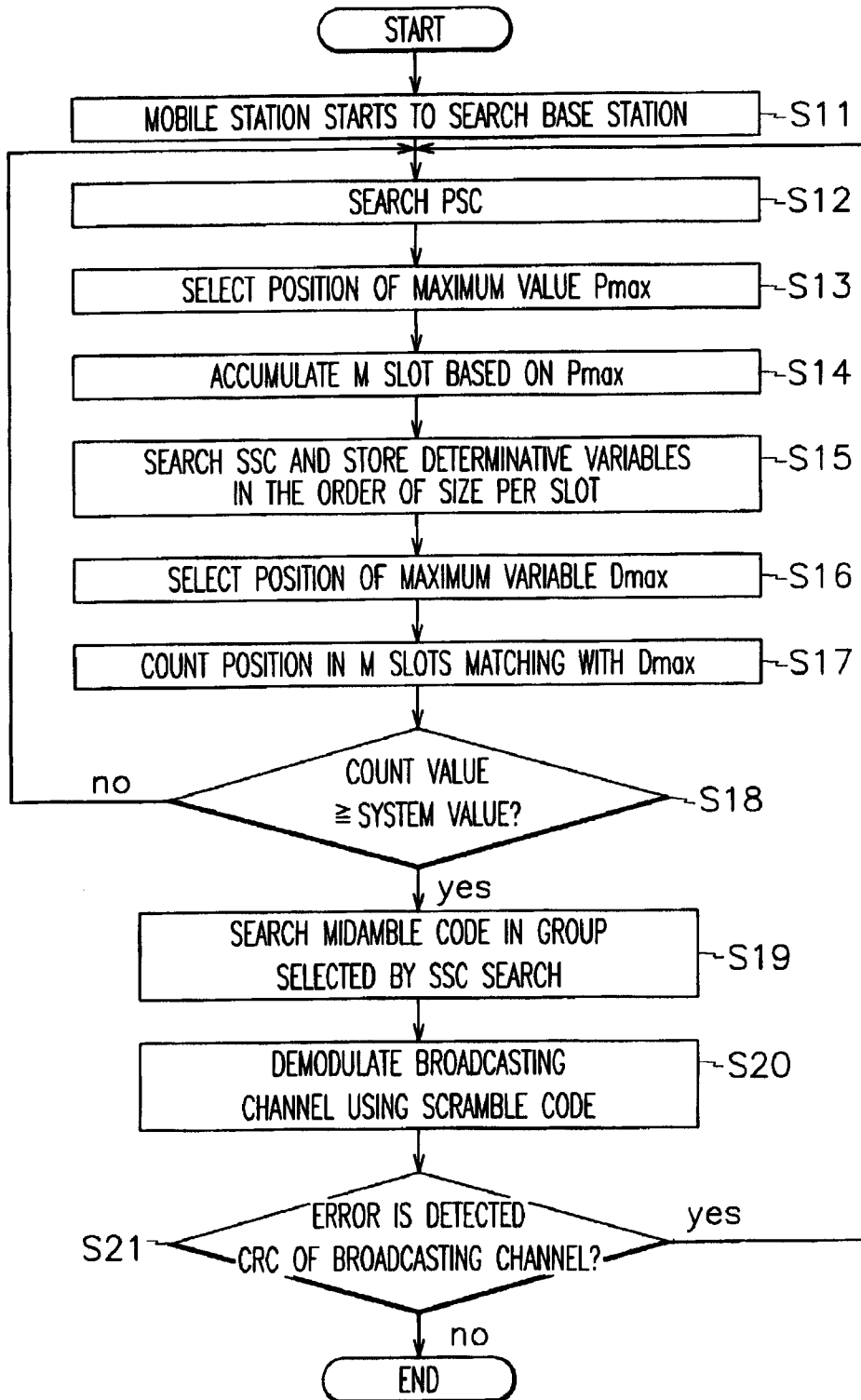

FIG. 5



CELL SEARCH SYSTEM FOR MOBILE STATION IN TIME DIVISION DUPLEX SYSTEM AND METHOD FOR THE SAME

Matter enclosed in heavy brackets [] appears in the original patent but forms no part of this reissue specification; matter printed in italics indicates the additions made by reissue.

CROSS REFERENCE TO RELATED APPLICATIONS

The present patent application is a Reissue of U.S. Pat. No. 7,321,584, issued on Jan. 22, 2008, which claims the priority of Korean Patent Application No. 2001-0065989, filed on Oct. 25, 2001, in the Korean Intellectual Property Office, the disclosures of which are incorporated herein by reference.

BACKGROUND OF THE INVENTION

(a) Field of the Invention

The present invention relates to a cell search system for a mobile station in a time division duplex system, and a method for the same. More specifically, the present invention relates to a cell search system for a mobile station in a time division duplex system and a method for the same in which the mobile station searches secondary synchronization codes for initial synchronization acquisition without determining a threshold value in the system, and then enters the checking mode, thereby reducing the initial synchronization acquisition time.

(b) Description of the Related Art

In a time division duplex (TDD) system, the same frequency is used in transmitting and receiving data. The TDD system employs a time division multiple access method in

FIG. 1 is an illustration of a sync channel configuration in a general TDD system.

In the TDD system, base stations send sync channels for each frame, as shown in FIG. 1, so that the mobile station performs an initial synchronization search.

The sync channel configuration shown in FIG. 1 is an example of the current standards in the TDD system. The sync channel is classified into primary synchronization codes (PSC) and secondary synchronization codes (SSC), and carries one PSC and three SSCs, each having a length of 256 on two slots per frame.

In FIG. 1, one frame consists of 15 slots having a length of 10 ms, and P_P and P_S are the code powers of the PSC and the SSC, respectively.

FIG. 2 shows an example of the code structure forming the sync channel of FIG. 1.

In the code structure of PSC C_P and SSC C_S as shown in FIG. 2, the position of the sync channel, if carried on two slots per frame and starting from slot k, is slots k, k+8, k+15, and k+23.

The SSCs are generated by multiplexing a 256-cycle Hadamard sequence by a 256-length code consisting of a combination of 8-length codes $A=\{1, 1, 1, 1, 1, 1, -1, -1\}$ and $B=\{1, -1, 1, -1, 1, -1, -1, 1\}$ and modulating $\{\pm 1, \pm j\}$ every 256-length code.

The SSCs are generalized hierarchical Golay (GHG) codes, and they are constructed as a combination of A and B, as illustrated in FIG. 2.

Table 1 shows an example of SSCs modulated according to groups and slots. Three SSCs are modulated by $\{\pm 1, \pm j\}$ and, as illustrated in FIG. 2, transmitted twice every frame, the same SSC being repeated every two frames.

TABLE 1

Code	Code	Frame 1						Frame 2						t_{offset}
		Group	Set	Slot k	Slot k + 8	Slot k	Slot k + 8	Group	Set	Slot k	Slot k + 8			
0	1	C_1	C_2	C_5	C_1	C_3	$-C_5$	$-C_1$	$-C_3$	C_5	$-C_1$	$-C_3$	$-C_5$	t_0
1	1	C	$-C_3$	C_5	C_1	$-C_3$	$-C_5$	$-C_1$	C_3	C_5	$-C_1$	C_3	$-C_5$	t_1
2	1	jC_1	jC_3	C_5	jC_1	jC_3	$-C_5$	$-jC_1$	$-jC_3$	C_5	$-jC_1$	$-jC_3$	$-C_5$	t_2
3	1	jC_1	$-jC_3$	C_5	jC_1	$-jC_3$	$-C_5$	$-jC_1$	jC_3	C_5	jC_1	jC_3	$-C_5$	t_3
4	1	jC_1	jC_5	C_3	jC_1	jC_5	$-C_3$	$-jC_1$	$-jC_5$	C_3	$-jC_1$	$-jC_5$	$-C_3$	t_4
5	1	jC_1	$-jC_5$	C_3	jC_1	$-jC_5$	$-C_3$	$-jC_1$	jC_5	C_3	$-jC_1$	jC_5	$-C_3$	t_5
6	1	jC_3	jC_5	C_1	jC_3	jC_5	$-C_1$	$-jC_3$	$-jC_5$	C_1	$-jC_3$	$-jC_5$	$-C_1$	t_6
7	1	jC_3	$-jC_5$	C_1	jC_3	$-jC_5$	$-C_1$	$-jC_3$	jC_5	C_1	$-jC_3$	jC_5	$-C_1$	t_7
8	2	C_{10}	C_{13}	C_1	C_{10}	C_{13}	$-C_{14}$	$-C_{10}$	$-C_{13}$	C_{14}	$-C_{10}$	C_{13}	$-C_{14}$	t_8
9	2	C_{10}	$-C_{13}$	C_1	C_{10}	$-C_{13}$	$-C_{14}$	$-C_{10}$	$0C_{13}$	C_{14}	$-C_{10}$	C_{13}	$-C_{14}$	t_9
10	2	jC_{10}	jC_{13}	C_{14}	jC_{10}	jC_{13}	$-C_{14}$	$-jC_{10}$	$-jC_{13}$	C_{14}	$-jC_{10}$	$-jC_{13}$	$-C_{14}$	t_{10}
11	2	jC_{10}	$-jC_{13}$	C_{14}	jC_{10}	$-jC_{13}$	$-C_{14}$	$-jC_{10}$	jC_{13}	C_{14}	$-jC_{10}$	jC_{13}	$-C_{14}$	t_{11}
12	2	jC_{10}	jC_{14}	C_{13}	jC_{10}	jC_{14}	$-C_{13}$	$-jC_{10}$	$-jC_{14}$	C_{13}	$-jC_{10}$	$-jC_{14}$	$-C_{13}$	t_{12}
13	2	jC_{10}	$-jC_{14}$	C_{13}	jC_{10}	$-jC_{14}$	$-C_{13}$	$-jC_{10}$	jC_{14}	C_{13}	$-jC_{10}$	jC_{14}	C_{13}	t_{13}
14	2	jC_{13}	jC_{14}	C_{10}	jC_{13}	jC_{14}	$-C_{10}$	$-jC_{13}$	$-jC_{14}$	C_{10}	$-jC_{13}$	$-jC_{14}$	$-C_{10}$	t_{14}
15	2	jC_{13}	$-jC_{14}$	C_{10}	jC_{13}	$-jC_{14}$	$-C_{10}$	$-jC_{13}$	jC_{14}	C_{10}	$-jC_{13}$	jC_{14}	$-C_{10}$	t_{15}
16	3	C_0	C_6	C_{12}	C_0	C_6	$-C_{12}$	$-C_0$	$-C_6$	C_{12}	$-C_0$	$-C_6$	$-C_{12}$	t_{16}
23	3	jC_6	$-jC_{12}$	C_0	jC_6	$-jC_{12}$	$-C_0$	$-jC_6$	jC_{12}	C_0	$-jC_6$	jC_{12}	$-C_0$	t_{20}
24	4	C_4	C_8	C_{15}	C_4	C_8	$-C_{15}$	$-C_4$	$-C_8$	C_{15}	$-C_4$	$-C_8$	$-C_{15}$	t_{24}
31	4	jC_8	$-jC_{15}$	C_4	jC_8	$-jC_{15}$	$-C_4$	$-jC_8$	jC_{15}	C_4	$-jC_8$	jC_{15}	$-C_4$	t_{31}

which each 10 ms long frame is divided into 15 time slots to be shared among multiple users. The TDD system is one of the wireless access standards for IMT-2000 using a code division multiple access method to support multiple simultaneous users.

An advantage of the TDD system is that it is capable of adapting to determine the direction of data communications so as to provide asymmetric data services such as Internet efficiently, in the aspect of frequency.

FIG. 3 is a flow chart showing a cell search method for a mobile station in a TDD system according to an example of the prior art.

As shown in FIG. 3, upon receiving a sync channel, in step 1, the mobile station searches PSCs with a matcher to detect a maximum value of PSCs, in step 2.

The mobile station decides in step 3 whether the maximum value exceeds a first threshold predetermined in the system. When the maximum value does not exceed the first threshold,

the mobile station searches PSCs again; otherwise, when the maximum value exceeds the first threshold, the mobile station determines the position of the maximum value as that of the sync channel, in step 4.

Using the position of the sync channel and SSCs, the mobile station searches information, such as the group of the base station to which it belongs, slot boundary, and the position of the sync channel in the frame, in step 5.

The mobile station uses the information about the group to which it belongs to get the knowledge of four predetermined midamble codes and scramble codes, in step 6. Then the mobile station selects a maximum value of the four midamble codes and decides in step 7 whether the maximum midamble code exceeds a second threshold predetermined in the system.

When the maximum midamble code exceeds the second threshold, the mobile station decides that it has acquired its base station, and detects the scramble codes from the selected midamble code to demodulate broadcasting channels from the scramble codes, in step 8.

When the maximum midamble code does not exceed the second threshold, the mobile station decides that it has failed to acquire its base station, and searches PSCs again, in step 9.

The base station search method for the mobile station as described above has a problem in that it is difficult to accurately determine the threshold values for the PSC search, because the power of the received signal dramatically changes due to channel environments when the mobile station receives the signals from the base station.

This difficulty in determining the accurate threshold values for the PSC search causes an increase in the probability of false alarms or defectives according to the threshold values for the PSC search, and increases the cell search time.

SUMMARY OF THE INVENTION

It is an object of the present invention to solve the problems with the prior art and to provide a cell search system for a mobile station in a time division duplex system, and a method for the same, in which the mobile station searches secondary synchronization codes without the system's determining a threshold value and then enters the checking mode to decide whether or not synchronization is acquired, thereby reducing the time required for searching for its base station.

To achieve the object of the present invention, a cell search system for a mobile station in a time division duplex system is provided that includes: a primary synchronization code search module for searching primary synchronization codes for a predetermined search frame using received signals from a base station and generated primary synchronization codes, and comparing frame values of the primary synchronization codes to determine a position of the maximum value; a correlation module for estimating a phase value necessary for demodulation of secondary synchronization codes from the primary synchronization codes searched by the primary synchronization code search module, and detecting a correlation between the received signals and codes forming the secondary synchronization codes using the estimated phase value and the position of the maximum value determined by the primary synchronization code search module to acquire a first correlation value; a secondary synchronization code search module for generating determinative variables using the first correlation value of the correlation module, accumulating M slots based on the position of the maximum value, sorting, in the order of size, as many of the determinative variables of the respective M slots as can be sorted in a predetermined buffer size, and storing the sorted determinative variables; a comparison and decision module for detecting a maximum value

of the determinative variables of the secondary synchronization code search module, comparing the maximum variable value with the values stored in the secondary synchronization code search module to count matching values, and comparing the count value with a predetermined system value to decide whether slot synchronization and group acquisition is successful; and a base station determination module for detecting a correlation between the received signals and midamble codes in the group generated according to the decision result of the comparison and decision module to determine a second correlation value, and selecting a maximum of the second correlation values to determine the base station to which the mobile station belongs.

The cell search system further includes a channel demodulation module for searching scramble codes according to the midamble codes to demodulate broadcasting channels, upon the base station determination module determining the base station.

The primary synchronization code search module includes: a primary synchronization code generator for generating primary synchronization codes; a matcher for loading the primary synchronization code values generated from the primary synchronization code generator for a predetermined search frame, and for matching the respective primary synchronization code values with the received signal to output a predetermined number of output values for the search frame; and a first comparator for comparing the output values of the matcher to detect the position of the maximum value.

The correlation module includes: a phase estimator for estimating a phase for modulating the secondary synchronization codes from the primary synchronization codes; a secondary synchronization code generator for generating extension codes forming the secondary synchronization codes; and a first correlator for detecting a correlation between the extension codes of the secondary synchronization code generator and the received signals using the position of the maximum value from the primary synchronization code search module and the phase value estimated by the correlation module to determine the first correlation value, and for integrating the first correlation value.

The secondary synchronization code search module includes: a Hadamard converter for Hadamard-converting the correlation values of the correlation module; a code cell storage section for storing the secondary synchronization codes modulated according to information about the group to which the mobile station belongs; a calculator for operating the output values of the Hadamard converter and the modulated secondary synchronization code values from the code cell storage section to generate determinative variables; an accumulator for accumulating M slots determined according to the sync channels per search frame based on the position of the maximum value selected by the primary synchronization code search module; and a comparison and storage section for storing, in the order of size, as many of the determinative variables of the respective M slots as can be stored in a predetermined buffer size.

The comparison and decision module includes: a detector for detecting a maximum value of the determinative variables generated from the secondary synchronization code search module; a second comparator for comparing the values stored in the secondary synchronization code search module with the maximum value of the determinative variables from the detector to count matching values; and a decider for comparing the count value of the second comparator with a predetermined system value to decide whether slot synchronization and group acquisition is successful.

The base station determination module includes: a midamble code generator for generating midamble codes in the group when the comparison and decision module decides that slot synchronization and group acquisition is successful; a second correlator for detecting a correlation between the midamble codes generated from the midamble code generator and the received signals to output second correlation values; and a maximum value detector for detecting a maximum value of the second correlation values from the correlator to determine the base station to which the mobile station belongs.

The comparison and decision module sends a command to the primary synchronization code search module to search the primary synchronization codes again, when slot synchronization and group acquisition is not successful.

In another aspect of the present invention, there is provided a cell search method for a mobile station in a time division duplex system that includes: (a) upon turning on power, the mobile station's searching for a base station to which it belongs, and searching primary synchronization codes for a predetermined search frame to determine a position of the maximum value during the search frame; (b) the mobile station's extracting M slots from the position of the maximum value determined in the step (a), searching and accumulating secondary synchronization codes for M slots, sorting, in the order of size, as many of the secondary synchronization codes as can be sorted in a predetermined buffer size per slot, and storing the sorted secondary synchronization codes; (c) determining a position of the maximum variable among the secondary synchronization code values accumulated in the step (b), and counting matching position values in the M slots having the maximum variables sorted in the order of size; (d) comparing the count value of the step (c) with a predetermined system value to decide whether slot synchronization and group acquisition is successful; and (e) searching midamble codes from the group determined by the secondary synchronization code search and detecting a maximum value of the midamble codes to determine the base station to which the mobile station belongs, when slot synchronization and group acquisition is successful.

The cell search method further includes: (f) performing a primary synchronization code search again, when slot synchronization and group acquisition is not successful.

The step (d) includes: deciding that slot synchronization and group acquisition is successful, when the count value of the step (c) is equal to or greater than the system value; and deciding that slot synchronization and group acquisition is not successful, when the count value of the step (c) is less than the system value.

The step (e) includes: searching scramble codes from the midamble codes and demodulating broadcasting channels using the scramble codes.

The step of demodulating the broadcasting channels includes: performing a cyclic redundancy check (CRC) of the demodulated broadcasting channels to decide whether there is an error; and performing a primary synchronization code search again when there is an error, or deciding that the base station search is successful and ending the search process when there is no error.

BRIEF DESCRIPTION OF THE DRAWINGS

The accompanying drawings, which are incorporated in and constitute a part of the specification, illustrate an embodiment of the invention, and, together with the description, serve to explain the principles of the invention:

FIG. 1 is an illustration showing a sync channel configuration in a general time division duplex (TDD) system;

FIG. 2 is an illustration showing an example of the code structure forming the sync channel of FIG. 1;

FIG. 3 is a flow chart showing a cell search method for a mobile station in a TDD system according to an example of the prior art;

FIG. 4 is a block diagram showing a base station search system for a mobile station in a TDD system according to an embodiment of the present invention; and

FIG. 5 is a flow chart showing a cell search method for a mobile station in a TDD system according to an embodiment of the present invention.

DETAILED DESCRIPTION OF THE PREFERRED EMBODIMENTS

In the following detailed description, only the preferred embodiment of the invention has been shown and described, simply by way of illustration of the best mode contemplated by the inventor(s) of carrying out the invention. As will be realized, the invention is capable of modification in various obvious respects, all without departing from the invention. Accordingly, the drawings and description are to be regarded as illustrative in nature, and not restrictive.

In the IMT-2000 broadband TDD mode, each base station has a unique scramble code, in which case it takes too much time for the mobile station to acquire the initial synchronization. Hence, base stations in the broadband TDD mode use sync channels.

In the case of using sync channels, the mobile station acquires slot synchronization with a group of base stations including the base station to which it belongs, and searches midamble codes in the group to determine its base station.

FIG. 4 is a block diagram showing a base station search system for a mobile station in a TDD system according to an embodiment of the present invention.

The system according to the embodiment of the present invention comprises, as shown in FIG. 4, a primary synchronization code (PSC) search module **100**, a phase estimator **200**, a correlation module **300**, a secondary synchronization code (SSC) search module **400**, a comparison and decision module **500**, a decider **600**, a base station determination module **700**, and a channel demodulation module **800**.

The PSC search module **100** searches PSCs for L search frames, and compares the frame values from the respective PSCs to select a position of the maximum value P_{max} . The phase estimator **200** estimates a phase necessary for demodulating SSCs modulated by $\{\pm 1, \pm j\}$ from the PSCs detected by the PSC search module **100**.

The correlation module **300** uses the position of the maximum value P_{max} detected by the PSC search module **100** and the phase value estimated by the phase estimator **200** to detect a correlation between received signals and codes forming SSCs and to determine a first correlation value.

The SSC search module **400** generates determinative variables using the first correlation value of the correlation module **300** and accumulates M slots based on the position of the maximum value P_{max} to sort, in the order of size, as many of the determinative variables of the respective M slots as can be sorted in a predetermined buffer size.

The comparison and decision module **500** detects the maximum value D_{max} of the determinative variables from the SSC search module **400** and compares the maximum value D_{max} with the values stored in the SSC search module **400** to count matching values. The decider **600** compares the count value of the comparison and decision module **500** with a

predetermined system value to decide whether or not slot synchronization and group acquisition is successful.

The base station determination module **700** detects a correlation between the midamble codes in the group generated according to the output of the decider **600** and received signals to calculate a second correlation value, and selects a maximum of the second correlation values to determine the base station to which the mobile station belongs. Upon the base determination module **700** determining the base station, the channel demodulation module **800** searches scramble codes according to the midambles and demodulates broadcasting channels.

The PSC search module **100** comprises: a PSC generator **110** for generating PSCs; a matcher **120** for loading all PSC values from the PSC generator **110** for a search frame and matching the respective PSC values with the received signals to output L frame values; and a first comparator **130** for comparing the frame values from the matcher **120** to detect a position of the maximum value P_{max} .

If the mobile station transmits sync channels for two slots per frame and searches two frames ($L=2$), as an example, four PSCs are generated for two frames, and the position of the maximum value P_{max} is one of the positions of the four PSCs when the mobile station accurately acquires synchronization of PSCs.

The correlation module **300** comprises: a SSC generator **310** for generating codes {A, B} forming SSCs, i.e., extension codes; and a first correlator **320** for detecting a correlation between the extension codes of the SSC generator **310** and received signals using the position of the maximum value P_{max} of the first comparator **130** and the phase value estimated by the phase estimator **200** to detect a first correlation value, and for accumulating a part of the first correlation values.

The SSC search module **400** comprises: a Hadamard converter **410** for performing a high-speed 16-cycle Hadamard conversion of the first correlation values from the first correlator **320** to generate 16 output values; a code cell storage section **420** for storing the SSCs used for determination of the groups and slots and which are modulated according to the information about the group to which the mobile station belongs; a calculator **430** for performing multiplication and addition using the output values of the Hadamard converter **410** and the modulated SSCs of the code cell storage section **420** to generate determinative variables; an accumulator **440** for accumulating M slots determined according to the sync channel per search frame based on the position of the maximum value P_{max} from the first comparator **130**; and a comparison and storage section **450** for storing, in the order of size, as many B determinative variables of the respective M slots as can be sorted in a predetermined buffer size.

The comparison and storage section **450**, which is to store B determinative variables for the respective M slots for SSC search in the order of size, may be an $M \times B$ memory.

Referring to Table 1, there are twelve SSCs: $C_0, C_1, C_2, C_3, C_4, C_5, C_6, C_8, C_{10}, C_{13}, C_{14},$ and C_{15} . Each of the 4 slots in the respective 32 groups has three modulated SSCs. 128 determinative variables are generated when performing multiplication and addition using these SSC values and the 16 output values of the Hadamard converter.

When the search interval is two frames and two sync channels exist every frame, $M=4$. In this case, the positions of the sync channels detected from the position of the maximum value P_{max} for L search frames are slots {0, 8, 15, 23} or {0, 7, 15, 22}. Hence, the number of determinative variables generated from the accumulator **440** accumulating M slots is 256 ($=128+128$).

The comparison and decision module **500** comprises: a detector **510** for detecting the maximum value D_{max} of the determinative variables from the accumulator **440**; and a second comparator **520** for comparing the B values stored in the comparison and storage section **450** with the maximum value D_{max} of the detector **510** to count matching values.

At $M=4$, the system value is 1, 2, 3, or 4. Hence when the count value of the second comparator **520** is equal to or greater than the system value, the decider **600** decides that slot synchronization and group acquisition is successful.

Otherwise, when the count value is less than the system value, the decider **600** decides that slot synchronization and group acquisition is not successful, and sends a command to the PSC search module **100** to perform a PSC search again.

For example, if 35 is the maximum value of the determinative variables after searching M slots while accumulating slots {0, 8, 15, 23} from the position of the maximum value P_{max} , there are 8 groups and 3 slots.

When $M=4, B=5$, and the stored values of the respective M slots are {0, 8, 15, 23} from the position of the maximum value P_{max} , $B=\{18, 50, 48, 35, 70\}$ at $M=1; B=\{112, 40, 110, 93, 43\}$ at $M=2; B=\{35, 67, 88, 10, 50\}$ at $M=3;$ or $B=\{89, 15, 49, 150, 35\}$ at $M=4$.

For the slots including the maximum value of 35 when accumulating M slots, M is 1, 3, or 4. When the count value of the second comparator is 3 and the system value is 2, that is, the count value is greater than the system value, the decider **600** decides that slot synchronization and group acquisition is successful.

The base station determination module **700** comprises: a midamble code generator **710** for generating midamble codes in the group upon the decider **600** deciding that slot synchronization and group acquisition is successful; a second correlator **720** for detecting a correlation between the midamble codes generated from the midamble code generator **710** and the received signals to output second correlation values; and a maximum value detector **730** for detecting a maximum of the second correlation values from the second correlator **720** to determine the base station to which the mobile station belongs.

In the case of 32 groups and 128 base stations, for example, there are four base stations in each group. When a group is selected, the second correlator **720** detects a correlation among the four midamble codes, and the maximum detector **730** selects a maximum of the correlation values to determine the base station to which the mobile station belongs.

In the case where the mobile station determines its base station by a midamble code search, the channel demodulation module **800** having the knowledge of the scramble codes according to the midamble codes demodulates broadcasting channels.

Now, a description will be given to an operation of the cell search system for a mobile station in a TDD system according to an embodiment of the present invention in detail with reference to the accompanying drawing.

FIG. 5 is a flow chart showing a cell search method for a mobile station in a TDD system according to an embodiment of the present invention.

As shown in FIG. 5, in the method of the present invention, the mobile station turns on the power and starts to search the base station to which it belongs, in step **11**. The mobile station searches PSCs using the PSC search module **100** for a predetermined search frame (L frames), in step **12**.

The PSC search module **100** determines a position of the maximum value P_{max} during the PSC search interval, in step **13**. The mobile station has the SSC search module **400**, via the phase estimator **200** and the correlation module **300**, search

SSCs from the position of the maximum value determined by the PSC search module 100 for M slots and accumulate the values of the SSCs, in step 14. Then the mobile station sorts, in the order of size, as many B determinative variables for the respective M slots as can be sorted in a predetermined buffer size and stores them, in step 15.

The comparison and decision module 500 detects a position of the maximum variable D_{max} among the determinative variables accumulated in the SSC search module 400, in step 16, and counts the position of the maximum variable in the M slots having the maximum variables sorted in the order of size, in step 17.

The decider 600 decides whether or not the count value of the comparison and decision module 500 is equal to or greater than a predetermined system value, in step 18. With the count value being less than the system value, the mobile station returns to the PSC search step.

When the count value is equal to or greater than the system value, the base station determination module 700 searches the midamble codes in the group selected by a SSC search to determine a maximum value of the midamble codes, in step 19.

Using scramble codes detected from the maximum midamble code, the channel demodulation module 800 demodulates broadcasting channels, in step 20.

Then the mobile station performs a cyclic redundancy check (CRC) to examine whether the demodulated broadcasting channels have CRC errors, in step 21. With the CRC errors in the broadcasting channels, the mobile station performs the PSC search again; otherwise, without the CRC errors, the mobile station decides that the base station search is successful and ends it.

According to the embodiment of the present invention, the mobile station searches sync channels in the initial synchronization acquisition step and then enters the checking mode, thereby reducing the initial synchronization acquisition time.

While this invention has been described in connection with what is presently considered to be the most practical and preferred embodiment, it is to be understood that the invention is not limited to the disclosed embodiments, but, on the contrary, is intended to cover various modifications and equivalent arrangements included within the spirit and scope of the appended claims.

As described above, according to the present invention, the mobile station searches secondary synchronization codes without the system determining threshold values, checks the presence of errors to decide whether or not synchronization acquisition is successful, and searches primary synchronization codes again when slot synchronization and group acquisition is not successful, or searches midamble codes when slot synchronization and group acquisition is successful, thereby reducing the base station search time in the wireless channel environments where the received power is extremely variable.

What is claimed is:

1. A cell search system for a mobile station in a time division duplex system, comprising:

- a primary synchronization code search module for searching primary synchronization codes for a predetermined search frame using received signals from a base station and generated primary synchronization codes, and comparing frame values of the primary synchronization codes to determine a position of the maximum value;
- a correlation module for estimating a phase value necessary for demodulation of secondary synchronization codes from the primary synchronization codes searched by the primary synchronization code search module, and

detecting a correlation between the received signals and codes forming the secondary synchronization codes using the estimated phase value and the position of the maximum value determined by the primary synchronization code search module to acquire a first correlation value;

- a secondary synchronization code search module for generating determinative variables using the first correlation value of the correlation module, accumulating M slots based on the position of the maximum value, sorting, in the order of size, as many of the determinative variables of the respective M slots as can be sorted in a predetermined buffer size, and storing the sorted determinative variables;

- a comparison and decision module for detecting a maximum value of the determinative variables of the secondary synchronization code search module, comparing the maximum variable value with the values stored in the secondary synchronization code search module to count matching values, and comparing the counted value with a predetermined system value to decide whether slot synchronization and group acquisition is successful; and

- a base station determination module for detecting a correlation between the received signals and midamble codes in the group generated according to the decision result of the comparison and decision module to determine a second correlation value, and selecting a maximum of the second correlation values to determine the base station to which the mobile stations belongs,

wherein the mobile station operates to search primary and secondary synchronization codes during initial acquisition without determining threshold values before entering checking mode to determine if synchronization is acquired, searches primary synchronization codes again when slot synchronization and group acquisition is not successful, and searches midamble codes only when slot synchronization and group acquisition is successful.

2. The system as claimed in claim 1, further comprising a channel demodulation module for searching scramble codes according to the midamble codes to demodulate broadcasting channels, upon the base station determination module determining the base station.

3. The system as claimed in claim 1, wherein the primary synchronization code search module comprises:

- a primary synchronization code generator for generating primary synchronization codes;
- a matcher for loading the primary synchronization code values generated from the primary synchronization code generator for a predetermined search frame, and for matching the respective primary synchronization code values with the received signal to output a predetermined number of output values for the search frame; and
- a first comparator for comparing the output values of the matcher to detect the position of the maximum value.

4. The system as claimed in claim 1, wherein the correlation module comprises:

- a phase estimator for estimating a phase for modulating the secondary synchronization codes from the primary synchronization codes;
- a secondary synchronization code generator for generating extension codes forming the secondary synchronization codes; and
- a first correlator for detecting a correlation between the extension codes of the secondary synchronization code generator and the received signals using the position of the maximum value from the primary synchronization code search module and the phase value estimated by the

11

correlation module to determine the first correlation value, and for integrating the first correlation value.

5. The system as claimed in claim 1, wherein the secondary synchronization code search module comprises:

- a Hadamard converter for Hadamard-converting the correlation values of the correlation module;
- a code cell storage section for storing the secondary synchronization codes modulated according to information about the group to which the mobile station belongs;
- a calculator for operating the output values of the Hadamard converter and the modulated secondary synchronization code values from the code cell storage section to generate determinative variables;
- an accumulator for accumulating M slots determined according to the sync channels per search frame based on the position of the maximum value selected by the primary synchronization code search module; and
- a comparison and storage section for storing, in the order of size, as many of the determinative variables of the respective M slots as can be stored in a predetermined buffer size.

6. The system as claimed in claim 1, wherein the comparison and decision module comprises:

- a detector for detecting a maximum value of the determinative variables generated from the secondary synchronization code search module;
- a second comparator for comparing the values stored in the secondary synchronization code search module with the maximum value of the determinative variables from the detector to count matching values; and
- a decider for comparing the counted value of the second comparator with a predetermined system value to decide whether slot synchronization and group acquisition is successful.

7. The system as claimed in claim 1, wherein the base station determination module comprises:

- a midamble code generator for generating midamble codes in the group when the comparison and decision module decides that slot synchronization and group acquisition is successful;
- a second correlator for detecting a correlation between the midamble codes generated from the midamble code generator and the received signals to output second correlation values; and
- a maximum value detector for detecting a maximum value of the second correlation values from the correlator to determine the base station to which the mobile station belongs.

8. The system as claimed in claim 1, wherein the comparison and decision module sends a command to the primary synchronization code search module to search the primary synchronization codes again, when slot synchronization and group acquisition is not successful.

9. A cell search method for a mobile station in a time division duplex system, comprising:

- (a) upon turning on power, the mobile station's searching for a base station to which it belongs, and searching primary synchronization codes for a predetermined search frame to determine a position of the maximum value during the search frame;
- (b) the mobile station's extracting M slots from the position of the maximum value determined in the step (a), searching and accumulating secondary synchronization codes for M slots, sorting, in the order of size, as many of the secondary synchronization codes as can be sorted in a predetermined buffer size per slot, and storing the sorted secondary synchronization codes;

12

- (c) determining a position of the maximum variable among the secondary synchronization code values accumulated in the step (b), and counting matching position values in the M slots having the maximum variables sorted in the order of size;
- (d) comparing the count value of the step (c) with a predetermined system value to decide whether slot synchronization and group acquisition is successful; and
- (e) searching midamble codes from the group determined by the secondary synchronization code search and detecting a maximum value of the midamble codes to determine the base station to which the mobile station belongs, only when slot synchronization and group acquisition is successful, wherein the mobile station searches primary and secondary synchronization codes during initial acquisition without determining a threshold value before entering checking mode to determine if synchronization is successful, and searches primary synchronization codes again when slot synchronization and group acquisition is not successful.

10. The method as claimed in claim 9, further comprising:

- (f) performing a primary synchronization code search again, when slot synchronization and group acquisition is not successful.

11. The method as claimed in claim 9, wherein the step (d) comprises:

- deciding that slot synchronization and group acquisition is successful, when the count value of the step (c) is equal to or greater than the system value; and
- deciding that slot synchronization and group acquisition is not successful, when the count value of the step (c) is less than the system value.

12. The method as claimed in claim 9, wherein the step (e) comprises:

- searching scramble codes from the midamble codes and demodulating broadcasting channels using the scramble codes.

13. The method as claimed in claim 12, wherein the step of demodulating the broadcasting channels comprises:

- performing a cyclic redundancy check (CRC) of the demodulated broadcasting channels to decide whether there is an error; and
- performing a primary synchronization code search again when there is an error, or deciding that the base station search is successful and ending the search process when there is no error.

14. A mobile station configured to conduct cell search, the mobile station comprising:

- a primary synchronization code search module configured to determine a position of a maximum primary synchronization code (PSC) value using received signals from a base station;
- a correlation module configured to acquire a first correlation value between the received signals and codes forming secondary synchronization codes (SSCs) using the position of the maximum PSC value;
- a secondary synchronization code search module configured to generate determinative variables using the first correlation value;
- a comparison and decision module configured to detect a maximum value of the determinative variables generated from the secondary synchronization code search module, compare the values stored in the secondary synchronization code search module with the detected maximum value of the determinative variables to count matching values, and compare the counted matching

13

values with a predetermined system value to decide whether slot synchronization and group acquisition is successful; and
 a base station determination module configured to determine the base station to which the mobile station belongs using a correlation between the received signals and midamble codes,
 wherein the mobile station is configured to search PSCs and SSCs without determining threshold values before deciding whether slot synchronization and group acquisition is successful,
 search PSCs again when the comparison and decision module decides slot synchronization and group acquisition is not successful, and
 search the midamble codes only when the comparison and decision module decides slot synchronization and group acquisition is successful.

15. The mobile station as claimed in claim 14, further comprising a channel demodulation module for searching scramble codes according to the midamble codes to demodulate broadcasting channels, upon the base station determination module determining the base station.

16. The mobile station as claimed in claim 14, wherein the primary synchronization code search module is configured to search PSCs for a predetermined search frame using the received signals from the base station and generated PSCs, and compare frame values of the PSCs to determine the position of the maximum PSC value.

17. The mobile station as claimed in claim 14, wherein the correlation module is configured to estimate a phase value necessary for demodulation of the SSCs from the PSCs searched by the primary synchronization code search module.

18. The mobile station as claimed in claim 14, wherein the secondary synchronization code search module is configured to accumulate M slots based on the position of the maximum PSC value, sorting, in the order of size, as many of the determinative variables of the respective M slots as can be sorted in a predetermined buffer size.

19. The mobile station as claimed in claim 14, wherein the base station determination module is configured to detect a correlation between the received signals and the midamble codes in the group generated according to a decision result of the comparison and decision module to determine a second correlation value, and selecting a maximum of the second correlation values to determine the base station to which the mobile stations belongs.

20. The mobile station as claimed in claim 14, wherein the primary synchronization code search module comprises:
 a primary synchronization code generator configured to generate PSCs;
 a matcher configured to load the PSC values from the primary synchronization code generator for a predetermined search frame, and to match the respective PSC values with the signals from the base station to output frame values for the predetermined search frame; and
 a first comparator configured to compare the frame values to determine the maximum PSC value within the predetermined search frame.

21. The mobile station as claimed in claim 14, wherein the correlation module comprises:
 a phase estimator configured to estimate a phase value for demodulation of the SSCs;
 a secondary synchronization code generator configured to generate extension codes forming the SSCs; and

14

a first correlator for detecting a correlation between the extension codes and the received signals using the maximum primary synchronization code value and the estimated phase value.

22. The mobile station as claimed in claim 14, wherein the secondary synchronization code search module comprises:
 a Hadamard converter configured to Hadamard-convert the correlation value of the correlation module;
 a code cell storage section configured to store the SSCs modulated according to information about the group to which the mobile station belongs;
 a calculator configured to operate the output values of the Hadamard converter and the modulated SSC values from the code cell storage section to generate determinative variables;
 an accumulator configured to accumulate M slots determined according to the sync channels per search frame based on the position of the maximum value selected by the primary synchronization code search module; and
 a comparison and storage section configured to store, in the order of size, as many of the determinative variables of the respective M slots as can be stored in the predetermined buffer size.

23. The mobile station as claimed in claim 14, wherein the base station determination module comprises:
 a midamble code generator for generating midamble codes in the group when the comparison and decision module decides that slot synchronization and group acquisition is successful;
 a second correlator for detecting a correlation between the midamble codes generated from the midamble code generator and the received signals to output second correlation values; and
 a maximum value detector for detecting a maximum value of the second correlation values from the correlator to determine the base station to which the mobile station belongs.

24. The mobile station as claimed in claim 14, wherein the comparison and decision module sends a command to the primary synchronization code search module to search the PSCs again, when slot synchronization and group acquisition is not successful.

25. A cell search method for a mobile station in a communication system having a plurality of base stations transmitting primary synchronization codes (PSCs) and a midamble code, the method comprising:
 on at least one functional unit,
 searching PSCs from received signals from the base station for a predetermined search frame to determine a position of a maximum value during the search frame;
 acquiring a first correlation value between the received signals and codes forming secondary synchronization codes (SSCs) using the position of the maximum PSC value;
 extracting M slots from the position of the maximum value, searching and accumulating SSCs for M slots, sorting, in order of size, as many of the secondary synchronization codes as can be sorted in a predetermined buffer size per slot, storing the SSCs, determining a position of the maximum variable among the accumulated SSC values, and counting matching position values in the M slots having the maximum variable numbers sorted in the order of size;
 deciding that slot synchronization and group acquisition is successful, when the count value is equal to or greater than the system value;

15

deciding that slot synchronization and group acquisition is not successful, when the count value is less than the system value; and

determining the base station to which the mobile station belongs using a correlation between the received signals and midamble codes,

wherein the mobile station is configured to search PSCs and SSCs without determining threshold values before deciding whether slot synchronization and group acquisition is successful,

search PSCs again when the functional unit decides slot synchronization and group acquisition is not successful, and

search the midamble codes only when the functional unit decides slot synchronization and group acquisition is successful.

26. The method as claimed in claim 25, further comprising a step of performing a PSC search again, when the functional unit decides slot synchronization and group acquisition is not successful.

27. The method as claimed in claim 25, wherein the step of acquiring a first correlation value comprises estimating a phase value necessary for demodulation of the SSCs from the PSCs searched by the primary synchronization code search module.

28. The method as claimed in claim 25, wherein the step of determining the base station comprises:

detecting a correlation between the received signals and the midamble codes in the group generated according to a decision result of the functional unit to determine a second correlation value; and

selecting a maximum of the second correlation values to determine the base station to which the mobile stations belongs.

29. The method as claimed in claim 28, further comprising searching scramble codes from the midamble codes and demodulating broadcasting channels using the scramble codes.

16

30. The method as claimed in claim 29, wherein the step of demodulating the broadcasting channels comprises performing a cyclic redundancy check (CRC) of the demodulated broadcasting channels to decide whether there is an error.

31. A cell search method for a mobile station, comprising: on at least one functional unit,

searching primary synchronization codes (PSCs) from received signals from a base station for a predetermined search frame to determine a position of the maximum value during the search frame;

acquiring a first correlation value between the received signals and codes forming secondary synchronization codes (SSCs) using the position of the maximum PSC value;

generating determinative variables using the first correlation value;

detecting a maximum value of the generated determinative variables;

comparing the values stored in the secondary synchronization code search module with the detected maximum value of the determinative variables to count matching values;

comparing the counted matching values with a predetermined system value to decide whether slot synchronization and group acquisition is successful; and

determining a base station to which the mobile station belongs using a correlation between the received signals and midamble codes,

wherein the mobile station is configured to search PSCs and SSCs without determining threshold values before deciding whether slot synchronization and group acquisition is successful,

search PSCs again when the functional unit decides slot synchronization and group acquisition is not successful, and

search the midamble codes only when the functional unit decides slot synchronization and group acquisition is successful.

* * * * *