



INTERNATIONAL APPLICATION PUBLISHED UNDER THE PATENT COOPERATION TREATY (PCT)

<p>(51) International Patent Classification⁴ : B65D 39/00, 41/32</p>	<p>A1</p>	<p>(11) International Publication Number: WO 87/ 05880 (43) International Publication Date: 8 October 1987 (08.10.87)</p>
<p>(21) International Application Number: PCT/US87/00598 (22) International Filing Date: 16 March 1987 (16.03.87) (31) Priority Application Number: 842,902 (32) Priority Date: 24 March 1986 (24.03.86) (33) Priority Country: US</p> <p>(71) Applicant: INVENTIVE PACKAGING CORPORATION [US/US]; 7900 E. Union Avenue, Suite 810, Denver, CO 80237 (US). (72) Inventor: COOKE, Carl, W. ; 5706 Perry Park Road, Sedalia, CO 80135 (US). (74) Agent: BEATON, Glenn, K.; 1700 Broadway, Suite 1800, Denver, CO 80290 (US).</p>		<p>(81) Designated States: AT (European patent), AU, BE (European patent), CH (European patent), DE (European patent), DK, FR (European patent), GB (European patent), IT (European patent), JP, LU (European patent), NL (European patent), SE (European patent).</p> <p>Published <i>With international search report.</i> <i>With amended claims and statement.</i></p>

(54) Title: TAMPER-RESISTANT PACKAGE

(57) Abstract

A tamper resistant package consisting of a container (10) and removable closure includes sealing means (12) comprising an insert (18) disposed in the interior of the container for sealing the container. The insert includes a tear-away section and a tab (22) affixed to the insert at the tear-away section. The tab normally extends upwardly for removing the tear-away section when it is desired to open the container. If the tear-away section is partially or completely broken away from the body of the insert the user is provided with a positive, readily ascertainable indication that the package has been previously opened and possibly tampered with.

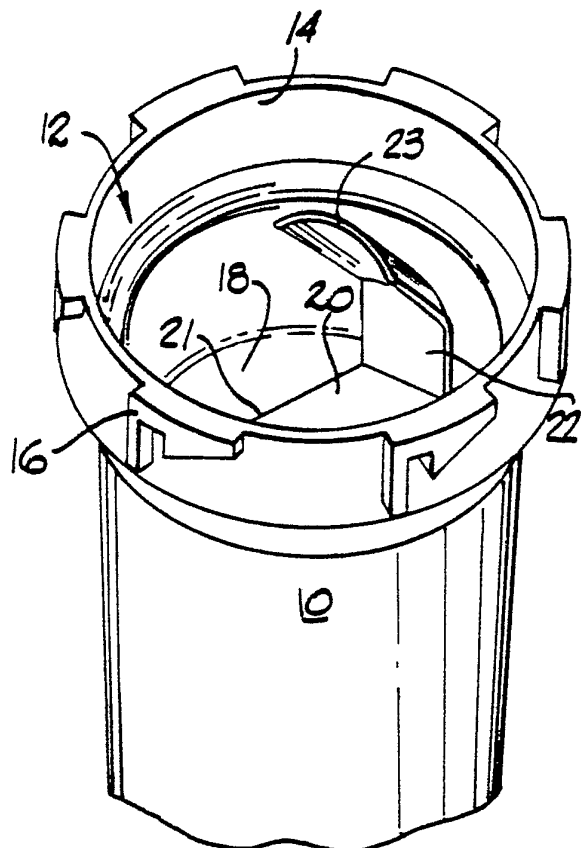

FOR THE PURPOSES OF INFORMATION ONLY

Codes used to identify States party to the PCT on the front pages of pamphlets publishing international applications under the PCT.

AT	Austria	FR	France	ML	Mali
AU	Australia	GA	Gabon	MR	Mauritania
BB	Barbados	GB	United Kingdom	MW	Malawi
BE	Belgium	HU	Hungary	NL	Netherlands
BG	Bulgaria	IT	Italy	NO	Norway
BJ	Benin	JP	Japan	RO	Romania
BR	Brazil	KP	Democratic People's Republic of Korea	SD	Sudan
CF	Central African Republic	KR	Republic of Korea	SE	Sweden
CG	Congo	LI	Liechtenstein	SN	Senegal
CH	Switzerland	LK	Sri Lanka	SU	Soviet Union
CM	Cameroon	LU	Luxembourg	TD	Chad
DE	Germany, Federal Republic of	MC	Monaco	TG	Togo
DK	Denmark	MG	Madagascar	US	United States of America
FI	Finland				

10

1

TAMPER-RESISTANT PACKAGE

15

Field of the Invention

20

This invention relates to tamper-resistant packaging and more particularly to means for economically sealing packages so as to make them resistant to tampering.

25

Background of the Invention

30

35

40

45

50

55

60

65

In recent years it has become a major concern of manufacturers of products designed for human consumption, such as pharmaceutical products, foodstuffs and the like, that the packages be resistant to tampering by individuals bent on the introduction of deleterious substances into the packages. For example, over the past several years there have been several examples of individuals who opened containers on the merchants shelf and introduced substances into the containers, i.e. cyanide and other poisonous substances which ultimately resulted in the death of persons who purchased and consumed the product without any warning that the product had been tampered with. In addition to the unfortunate deaths of the product users, such tampering, or the threat of tampering, has resulted in costly product recalls and loss of consumer confidence in the product and in the manufacturer of the product. As a result of these activities manufacturers and suppliers have been required to adopt relatively expensive measures to seal the product containers and packages in an attempt to protect the product against tampering. Such measures include the use of shrink fit materials over the outer packages as well as over the product containers themselves. Although such

5

-2-

10

15

20

measures do provide some degree of protection against tampering, there is a substantial expense involved. For example, it has been estimated that for a bottle of non-prescription pain reliever the cost of attempting to protect against tampering run about \$0.20-0.40 per bottle.

25

30

Accordingly it would be desirable to provide an economical means for sealing the containers of consumable products, which means would provide some protection against tampering and a positive indication that the product container has been opened thereby warning the user that the product may not be safe to use.

Summary of the Invention

35

40

45

50

55

60

65

The present invention provides means for sealing a container which includes a sealing member disposed in the opening of the container and which normally seals the interior of the container until the product is ready to use. A portion of the sealing member is scored to define a tear-away section and an upstanding tab member is disposed on the tear-away section which when pulled will cause the tear-away section to part from the remainder of the sealing member to define an opening for the container. If the tear-away section is partly or completely broken away or removed from the sealing member, the user of the product will be aware that the container has been unsealed and possibly that the contents have been tampered with.

In a preferred embodiment of the invention, the sealing means comprises an insert adapted to be received within a container consisting of a sealing member, an upstanding annular skirt portion, preferably integrally formed with the sealing member, which is adapted to be

-3-

10

15

20

25

30

received in the neck portion of the container and which acts to retain the sealing member in its position in the container. Preferably, the inserted sealing member and the container are comprised of materials which are readily bonded together by automated methods such as ultrasonic welding and the like. In another embodiment of the invention, the sealing insert and the container may be provided with cooperating locking elements such as an annular rib and corresponding annular groove which provide a snap lock action for retaining the insert in its position in the container.

Brief Description of the Drawings

35

FIG. 1 is an isometric view of a container, partially broken away for compactness of illustration, with the sealing member of the present invention disposed in the container;

40

FIG. 2 is a isometric view illustrating one embodiment of the sealing member of the present invention prior to insertion in a container;

45

FIG. 3 is a plan view of the sealing member of FIG. 1; and

50

FIGS. 4a, 4b, and 4c are sectional views of a portion of the sealing member and container wall illustrating various methods for retaining the sealing member in position.

55

Description of the Invention

60

Referring to FIG. 1 there is illustrated a container 10 which is provided with tamper resistant sealing means, shown generally as 12, in accordance with the invention. The container 10 may be of any type commonly used for pharmaceutical products, food products and the

65

-4-

10

like, such as a container having a defined constricted
15 neck portion or as illustrated, a straight sided
container having an opening 14, the circumference of
which is substantially the same as the circumference of
20 the interior of the container. The rim portion of the
container 10 adjacent the opening 14 is provided with
locking elements 16 which cooperate with corresponding
locking elements on a closure (not shown) for securing
25 the closure on the container. Alternatively, the
container 10 may be provided with threads which cooperate
with matching threads on the closure to secure the
30 closure on the container.

The sealing means 12 comprises a sealing member
18 which is disposed in the interior of the container
35 normally adjacent the opening 14 which is retained by
means which will be explained in more detail hereinafter
and which seals the interior of the container 10. The
relative axial position of the sealing member 18 with
40 respect to the opening 14 of the container 10 is selected
depending upon the nature of the contents of the
container so that the sealing member 18 may also be used
45 as a packing or securing means for the products within
the container 10, in the same fashion as is served by
cotton or other types of packing material. The sealing
member 18 is provided with a tear-away section 20 which
50 is defined by score line 21. An upstanding tab member 22
is secured on the tear-away section 20, preferably at one
end thereof, and extends upwardly towards the opening 14
55 of the container. The upper end portion 23 of the tab
member 22 may be disposed substantially perpendicularly
to the tab member to aid in gripping the tab member when
60 removing the tear-away section 20.

65

-5-

10

15

20

25

30

35

40

45

50

55

60

65

For manufacturing economy the sealing means 12 is preferably formed separately from the container 10. As illustrated in FIG. 2 and FIG. 3, where like numbers designate like parts, the sealing means 10 is formed as an insert 25 consisting of the sealing member 18, which includes the tear-away section 20 defined by score line 21 and the tab member 22, and an upwardly extending skirt portion 27 which is preferably integrally formed with the sealing member 18. The insert 25 therefor defines a generally cylindrically shaped member which is closed at one end by the sealing member 18 and which is dimensioned so as to be received snugly in the opening 14 of the container 10. The open end of the insert 25 is provided with a lip 29 which is equivalent to or slightly larger than the rim of the container 109 so as to provide a stop for the insert 25 to accurately position the sealing member 18 within the container 10. The axial length of the skirt portion 27 is determined by the desired axial position of the sealing member 18 in the container.

In the preferred manufacturing practice, the insert 25 and the container 10 are constructed of the same or compatible materials which may be fused or bonded together. For example the insert 25 and the container 10 may both be formed of polypropylene or polyethylene copolymers which can be bonded together after the insert is positioned in the opening of the container by conventional means such as ultrasonic welding. In this fashion the insert is fused to and essentially becomes part of the container 10. In the alternative bonding materials, such as epoxy, may be utilized, particularly where the container is metal or glass so as to secure the insert 25 in the container 10. The use of separate bonding materials, however, does involve a separate operation

5
10
15 which adds to the cost manufacture and it is highly preferred to use materials which can be readily bonded or fused by automated methods, such as ultrasonic welding. In the alternative, particularly where the composition of the insert and the container differ or are not readily fusible or bondable, mechanical locking means may be employed to retain the insert in the container.

20
25 Referring to FIGS. 4a, 4b and 4c, there is illustrated several methods for retaining the insert 25 in the container 10. FIG. 4a illustrates a preferred embodiment wherein the outer surface of the skirt portion 27 is fused to the inner wall surface of the container 10. In this embodiment the composition of the insert and the composition of the container 10 are the same or are compatible materials which can be fused by ultrasonic welding. FIGS. 4b and 4c illustrate mechanical locking means for retaining the insert 25 in the container 10. Mechanical means are employed when the insert material and the container material do not lend themselves to bonding or fusing, such as for example where the container is made of glass or metal and the insert is made of metal or a polymeric material. As illustrated in FIG. 4b the skirt portion 27 of the insert 25 is provided with an annular ring 31 which is received in a corresponding groove 33 provided in the inner wall surface of the container 10. FIG. 4c illustrates yet another embodiment of mechanical locking means in which an annular rib 35 is disposed on the wall of the container 10 for being received in a corresponding groove 37 which is formed between a pair of spaced apart ribs 39a and 39b on the outer surface of the skirt portion 27 of the insert 25.

60 To unseal the container 10 with the sealing member 12 in place one simply pulls on the tab member 22

-7-

10

15

20

25

30

35

40

45

50

55

60

65

which by virtue of its attachment to the tear-away section 20 pulls the tear-away section away from the sealing member to define an opening for the container of same configuration as the tear-away section. As is most clearly shown in FIG. 3 the lower end of the tab member at the point of attachment to the tear-away member is broad and is provided with an extended portion 41 so that as the tab member is rocked about a fulcrum defined by its lower end the extended portion 41 acts as a lever to initiate tearing of the score line 21 at a point adjacent the extended portion of the tab. The configuration of the tear-away section 20 is largely dependent upon the nature of the product in the container 10. For example, assuming the contents of the container are pills or capsules, the opening of the container should be such as to permit only one, or at most, only a few tablets or capsules to be removed from the container at one time. This avoids the annoying problem of having the entire contents accidentally spill out when the user is attempting to extract a tablet or capsule.

While a preferred embodiment and modifications of the invention have been described in the foregoing description and illustrated in the drawings, it will be understood that minor changes may be made in the details of construction as well as in the combination and arrangement of parts without departing from the spirit and scope of the invention as claimed.

10

15 1. A tamper resistant package consisting of a
container having an interior and an opening, a removable
closure and sealing means for said container, said seal-
ing means comprising a sealing member disposed in the
20 interior of said container for sealing the opening, said
sealing member including a tear-away section defined by a
score line on said sealing member and a tab affixed to
25 said sealing member at the tear-away section thereof,
said sealing member normally sealing the interior of said
container until said tear-away section is deliberately
removed, thereby to provide a positive indication that
30 the package has been opened and providing communication
between the interior of said container the opening.

35 2. The tamper resistant package of claim 1
wherein said sealing means further includes an upwardly
extending skirt portion integrally formed with said seal-
ing member, said skirt portion being received in the
40 opening of said container and cooperating with the inner
walls of the interior for carrying and retaining said
sealing member therein.

45 3. The tamper resistant package of claim 2
wherein the outer surface of said upwardly extending
skirt portion is bonded to the inner surface of the
interior wall said container.

50 4. The tamper resistant package of claim 2
wherein the outer surface of the skirt portion of said
sealing means is provided with an annular rib and the
inner wall of the interior of said container is provided
55 with a corresponding annular groove for receiving the
annular rib thereby to carry and retain said sealing
means therein.

60 5. The tamper resistant package of claim 2
wherein the outer surface of the skirt portion of said

65

5

-9-

10

15 sealing means is provided with a pair of spaced annular ribs which define therebetween an annular groove and the inner surface of the interior of said container is provided with a corresponding annular rib which is received in the annular groove of said sealing means thereby to carry and retain said sealing means therein.

20
25 6. A tamper resistant sealing insert for a container comprising a cylindrically shaped body closed at one end to define a sealing member and open at the opposite end to define upwardly extending skirt portion, said sealing member being scored to define a tear-away section thereof and a tab member located on the tear-away section of said sealing member and extending toward the open end of said insert, whereby removal of said tear-away section provides a positive indication that the container in which said insert is placed has been opened.

30
35
40 7. The insert of claim 6 wherein the lower end of the tab member at its point of attachment to the tear-away section of said sealing member is provided with a normally extending portion to aid in the initiation of tearing of the score line when the member is manipulated to remove the tear-away section of the sealing member.

45
50 8. The insert of claim 6 wherein the outer surface of the upstanding skirt portion is bonded to the interior wall surface of said container thereby to retain said sealing member in said container.

55 9. The insert of claim 6 wherein said upstanding skirt portion is provided with an annular rib adapted to be received in a corresponding annular groove in the interior wall of said container thereby to lock said sealing member in said container.

60 10. The insert of claim 6 wherein the upstanding skirt portion is provided with a pair of spaced

65

5

-10-

10

annular ribs which define therebetween an annular groove
15 adapted to receive an annular rib disposed on the
interior wall of said container for locking said insert
in said container.

20

25

30

35

40

45

50

55

60

65

AMENDED CLAIMS

[received by the International Bureau on 28 July 1987 (28.07.87);
original claims 1-10 replaced by new claims 11-14 (3 pages)]

11. (new). A tamper-resistant package consisting of
a container having an interior and an opening; a removable
closure and sealing means, said sealing means comprising a
35 sealing member disposed in the interior of said container for
sealing the opening, said sealing member including a tear-away
section defined by a score line on said sealing member and a
tab affixed to said sealing member at the tear-away section
thereof, said sealing member normally sealing the interior of

40

45

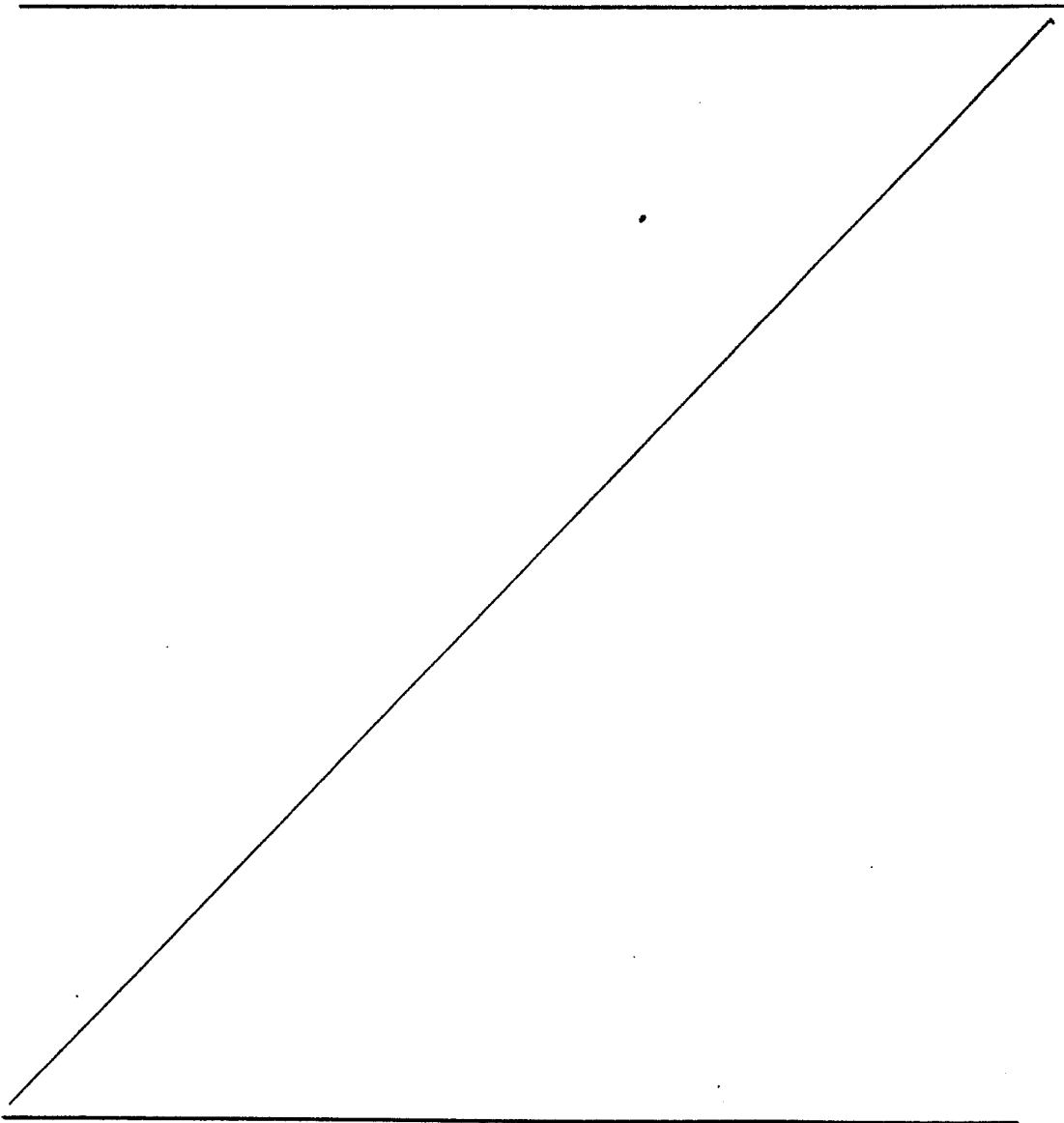

5

said container until said tear-away section is deliberately removed, thereby providing a positive indication that the package has been opened and providing communication between the interior of said container and the opening; an upwardly extending skirt portion integrally formed with said sealing member, said skirt portion being received in the opening of said container and cooperating with the inner walls of the container interior for carrying and retaining said sealing member therein; a pair of spaced annular ribs on the outer surface of the skirt portion of said sealing means which define therebetween an annular groove; and a corresponding cooperating annular rib on the inner surface of the interior of said container which is received in the annular groove of said sealing means, thereby to carry and retain said sealing means therein.

12. (new): A tamper resistant sealing insert for a container comprising a cylindrically shaped body closed at one end to define a sealing member and open at the opposite end to define an upwardly extending skirt portion, which skirt portion is provided with a pair of spaced annular ribs which define therebetween an annular groove adapted to receive an annular rib disposed on the interior wall of said container for locking said insert into said container, said sealing member being scored to define a tear-away section thereof; and a tab member located on the tear-away section of said sealing member and extending toward the open end of said insert, whereby removal of said tear-away section provides a positive indication that the container in which said insert is placed has been opened.

13. (new): A tamper resistant sealing insert for a container comprising a cylindrically shaped body closed at one end to define a sealing member and open at the opposite end to define an upwardly extending skirt portion, said sealing

40

45

5

member being scored to define a tear-away section thereof; a
tabbed member located on the tear-away section of said sealing
member and extending toward the open end of said insert,
10 whereby removal of said tear-away section provides a positive
indication that the container in which said insert is placed
has been opened; and means for translating a rocking motion on
the top of said tabbed member to an axial force drawing said
tear-away section apart from said sealing member.

15 14. (new): The insert of claim 15, wherein said
translating means includes a member extending from said tabbed
member to said tear-away section toward the scored portion of
said sealing member, so that a rocking force on said tab is
20 translated to an axial force on said tear-away section.

25

30

35

40

45

5

STATEMENT UNDER ARTICLE 19

The new claims replace the original claims set forth
10 in pages 8, 9 and 10 of the application.

The International Search Report indicated there was
no prior art of particular relevance with respect to claims 5
and 10. Claims 5 and 10 have therefore been recast in
15 independent form as new claims 11 and 12, incorporating all
the limitations of the claims from which they depended.

The applicant has also added new claims 13 and 14
directed to the leverage feature previously addressed in claim
20 7. The two new claims include "means for translating a
rocking motion on the top of said tabbed member to an axial
force drawing said tear-away section apart from said sealing
member", which is an element patentably distinct from the
cited reference of Schellenberg.

25

30

35

40

45

1/1

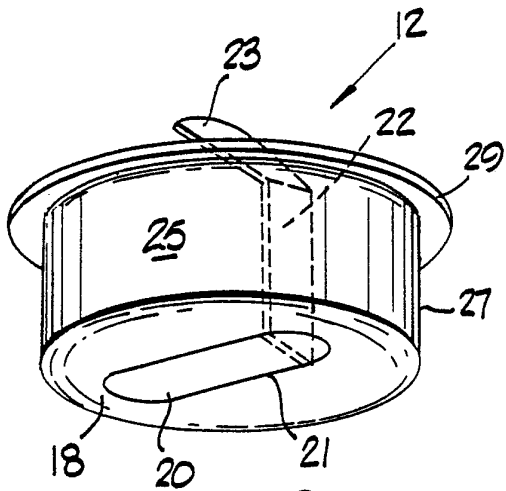

FIG. 2.

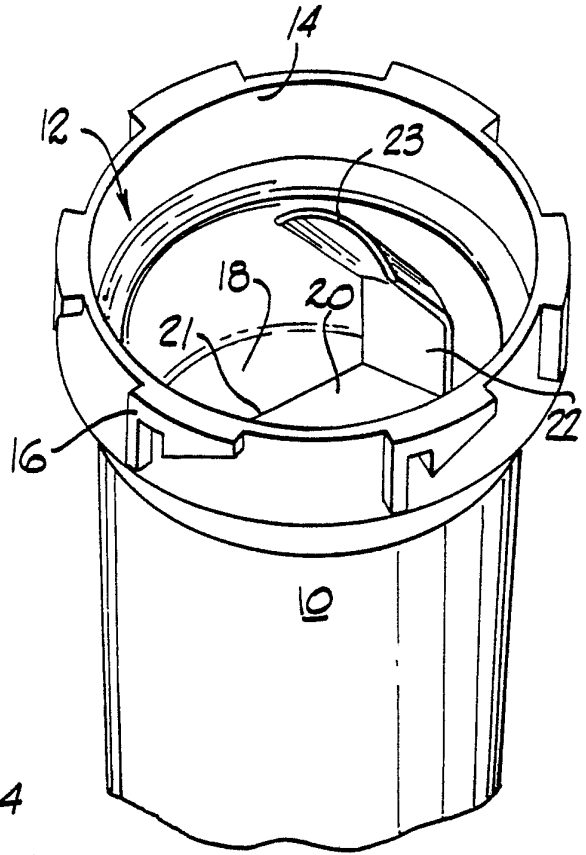

FIG. 1.

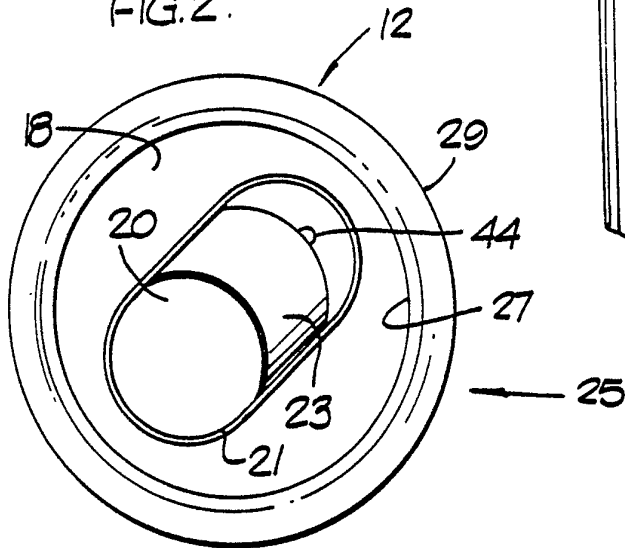

FIG. 3.

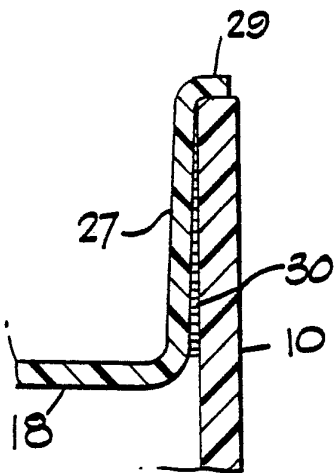

FIG. 4a.

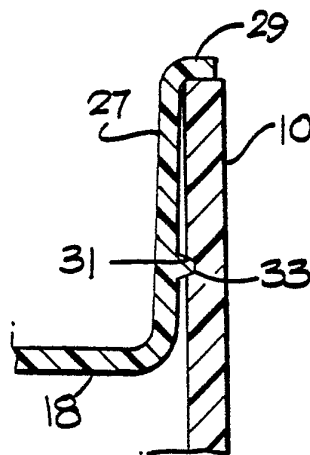

FIG. 4b.

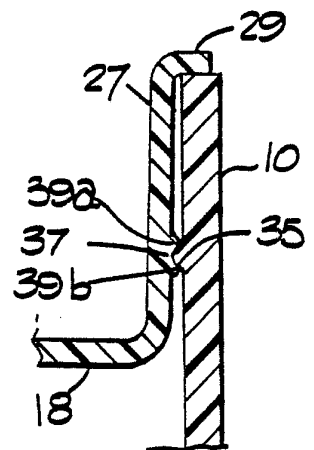

FIG. 4c.

INTERNATIONAL SEARCH REPORT

International Application No

PCT/US87/00598

I. CLASSIFICATION OF SUBJECT MATTER (if several classification symbols apply, indicate all) ³		
According to International Patent Classification (IPC) or to both National Classification and IPC IPC (4): B 6 5 D 39/00, 41/32 U.S. Cl. 215/254		
II. FIELDS SEARCHED		
Minimum Documentation Searched ⁴		
Classification System	Classification Symbols	
U.S.	220/258, 269, 270, 307, 359; 215/232, 254, 255, 355; 220/541	
Documentation Searched other than Minimum Documentation to the Extent that such Documents are Included in the Fields Searched ⁵		
III. DOCUMENTS CONSIDERED TO BE RELEVANT ¹⁴		
Category [*]	Citation of Document, ¹⁶ with indication, where appropriate, of the relevant passages ¹⁷	Relevant to Claim No. ¹⁸
A	US,A, 1,292,541 (Townsend) 28 January 1919	
A	US,A, 1,758,916 (Aulbach) 20 May 1930	
A	US,A, 2,428,354 (Blom) 07 October 1947	
Y	US,A, 3,089,609 (D'Andrea) 14 May 1963 See column 4, lines 28-40.	4
A	US,A, 3,273,737 (Davie) 20 September 1966	
<u>X</u> <u>Y</u>	US,A, 4,418,831 (Schellenberg) 06 December 1983 See column 4, lines 17-31.	<u>1-3, 6-8</u> 9
Y	FR,A, 936,244 (Remy et al) 13 July 1948 See Figure 2.	4,9
<p>[*] Special categories of cited documents: ¹⁵</p> <p>"A" document defining the general state of the art which is not considered to be of particular relevance</p> <p>"E" earlier document but published on or after the international filing date</p> <p>"L" document which may throw doubts on priority claim(s) or which is cited to establish the publication date of another citation or other special reason (as specified)</p> <p>"O" document referring to an oral disclosure, use, exhibition or other means</p> <p>"P" document published prior to the international filing date but later than the priority date claimed</p> <p>"T" later document published after the international filing date or priority date and not in conflict with the application but cited to understand the principle or theory underlying the invention</p> <p>"X" document of particular relevance; the claimed invention cannot be considered novel or cannot be considered to involve an inventive step</p> <p>"Y" document of particular relevance; the claimed invention cannot be considered to involve an inventive step when the document is combined with one or more other such documents, such combination being obvious to a person skilled in the art.</p> <p>"&" document member of the same patent family</p>		
IV. CERTIFICATION		
Date of the Actual Completion of the International Search ²		Date of Mailing of this International Search Report ²
27 April 1987		18 MAY 1987 -
International Searching Authority ¹		Signature of Authorized Officer ²⁰
ISA/US		Stephen Garbe 