

**(12) PATENT**  
**(19) AUSTRALIAN PATENT OFFICE**

**(11) Application No. AU 199887880 B2**  
**(10) Patent No. 749147**

(54) Title  
Biopolymer sponge tubes

(51)<sup>6</sup> International Patent Classification(s)  
A61L 015/32 A61L 027/00  
A61B 017/03 A61L 031/00  
A61L 015/28

(21) Application No: 199887880 (22) Application Date: 1998 .10 .02

(30) Priority Data

| (31) Number | (32) Date    | (33) Country |
|-------------|--------------|--------------|
| 9721079     | 1997 .10 .03 | GB           |

(43) Publication Date : 1999 .04 .22  
(43) Publication Journal Date : 1999 .04 .22  
(44) Accepted Journal Date : 2002 .06 .20

(71) Applicant(s)  
Johnson and Johnson Medical Limited

(72) Inventor(s)  
Paul William Watt; Reginald Stilwell; Alan LeBlanc

(74) Agent/Attorney  
FREEHILLS CARTER SMITH BEADLE,Level 43,101 Collins Street,MELBOURNE VIC 3000

**ABSTRACT**

The invention provides biopolymer sponge tubes (4) closed at one end for use in surgery. The preferred biopolymer is collagen. The biopolymer sponge tubes are prepared by forming an aqueous dispersion of the biopolymer, introducing the dispersion into tube-shaped moulds, freezing the dispersion in the moulds to form a shaped, aqueous dispersion, followed by freeze-drying the frozen aqueous dispersion. The tubes (23,24) are fitted over endoscopic surgical staplers to provide improved sealing of stapled tissues, especially for air-tight sealing in lung resections.

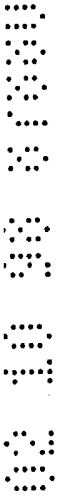



**AUSTRALIA**

*Patents Act 1990*

# **COMPLETE SPECIFICATION**

## **FOR A STANDARD PATENT**

**ORIGINAL**



---

Name of Applicant: **JOHNSON & JOHNSON MEDICAL LIMITED**

Actual Inventors: Paul William WATT; Reginald STILWELL and Alan LeBLANC

Address for service in Australia: **CARTER SMITH & BEADLE**  
2 Railway Parade  
Camberwell Victoria 3124  
Australia

Invention Title: **BIOPOLYMER SPONGE TUBES**

---

The following statement is a full description of this invention, including the best method of performing it known to us

---

BIOPOLYMER SPONGE TUBES

The present invention relates to biopolymer sponge tubes and the use thereof in surgery.

5

Surgical staple guns are widely used in the haemostasis and subsequent sealing of tissue following surgical procedures. For example, in the sealing of tissue following lung volume reductions for patients with emphysema. Typically, the linear surgical staplers have two separate barrels of differing dimensions, namely a staple cartridge and an anvil, which close together during the stapling. These instruments are indicated for use with a buttressing material, such as bovine pericardium, which surgeons use to reinforce staple lines and prevent leaks. According to current surgical procedure, the pericardium is wrapped around the barrels of the stapler prior to use. In use, the two barrels of the staple gun are placed on either side of the tissue that requires sealing. The stapling action brings together the two barrels with the pericardium, which is stapled into position at the appropriate site. The pericardium then acts as a seal to prevent exudate/air leakage.

The use of bovine pericardium in the above stapling procedure suffers from the drawbacks of possible antigenicity of the bovine pericardium, and lack of control over the precise shape, configuration and thickness of the bovine pericardium.

30

It would be desirable to provide an improved substitute for bovine pericardium for use in the above stapling procedure.

35

It is known to use mats, films or sponges of collagen as wound dressing materials. Collagen flake and sponge products for the treatment of wounds are described, for example, in EP-A-0314109.



It is also known to provide collagen tubes by the extrusion of a collagen gel into a coagulating bath. Such tubes have been used in micro-surgery, and for vascular prostheses. Implanted collagen films and/or collagen sponges  
5 have been suggested as slow-release matrices for therapeutic agents. The properties and applications of collagen biomaterials have been reviewed by A. Huc in Journal of American Leather Chemists Association, Vol. 80, pages 195-212 (1985).

10

US-A-3157524 describes forming porous collagen tubes by freezing an aqueous collagen slurry in a tubular mold, followed by solvent drying in an anhydrous isopropanol bath. Alternatively, the slurry may be frozen onto the outside of a  
15 tube through which a suitable refrigerant is passed, followed by solvent drying. The sponges are said to control bleeding in surgery through the application of pressure and coagulating material such as thrombin. No specific applications are disclosed.

20

It has now been found that biopolymer sponge tubes are highly suitable for replacing bovine pericardium in the surgical stapling procedure described above.

The present invention provides a method for producing  
25 biopolymer sponges comprising the steps of:

- (a) providing an aqueous dispersion of the biopolymer;
- (b) introducing the dispersion into a mold;
- (c) freezing the dispersion to provide a shaped frozen dispersion;
- 30 (d) heating the mold and releasing the shaped frozen dispersion from the mold; and
- (e) drying the released frozen dispersion.



The biopolymer sponge tube may be closed at one end to enable it to be fitted over a barrel of a staple gun without sliding too far along the barrel.

5 In one embodiment of the invention, a surgical stapler is provided comprising a staple cartridge and an anvil, and having a biopolymer sponge tube (which need not be closed at one end) fitted over the staple cartridge and/or over the anvil. Preferably, biopolymer sponge tubes are fitted over  
10 each of the staple cartridge and the anvil. Preferably, the biopolymer sponge tube or tubes are closed at one end.

The biopolymer sponge tubes may be used for the preparation of a surgical stapler as above for use in surgery.

15 The biopolymer used to make the sponge tubes may be any biocompatible and bioabsorbable polymer. Preferably, the biopolymer is selected from the group consisting of structural proteins, cellulose derivatives (including  
20 oxidised regenerated cellulose), starch derivatives, chitin, chitosan, glycosaminoglycans, and mixtures thereof. Preferred structural proteins include gelatin, all collagen types, keratin, laminin, fibrin or fibronectin. The phrase  
25 "all collagen types" encompasses type I and type II collagen, atelocollagen and other modified collagens. Suitable cellulose derivatives include carboxymethyl cellulose and hydroxyethyl cellulose, in addition to oxidised regenerated cellulose. Suitable alginates include sodium alginate, calcium alginate and mixtures thereof. Suitable  
30 glycosaminoglycans include hyaluronic acid, chondroitin sulphate, heparin and heparan sulphate.

The biopolymer sponge tube may be reinforced by a



biopolymer matrix, such as a Vicryl (registered trade mark) polylactide/polyglycolide mesh. However, preferably, the biopolymer sponge is not reinforced.

5 Preferably, the biopolymer sponge tube consists essentially of one or more collagen types. The collagen may be chemically cross-linked to modify its physical properties and rate of resorption *in vivo*. Collagen is the preferred biopolymer because of its easy availability, low cost, low  
10 antigenicity, and well-understood properties, which enable the collagen sponge to be prepared with controlled physical and biological behaviour.

The biopolymer sponge tube is preferably sterile.  
15 Preferably, the biopolymer sponge tube comprises less than 10% by weight of water to enable it to be stored indefinitely without decomposition. The biopolymer sponge tube preferably further comprises a therapeutic compound selected from the group consisting of antiseptics, such as chlorhexidine,  
20 antibiotics such as streptomycin, analgesics such as ibuprofen, steroids, cell growth factors and wound healing factors. Preferably, the therapeutic compound is present in amount of 0.01% to 2% by weight, based on the weight of the biopolymer sponge tube.

25 Preferably, the biopolymer sponge tube is fully bioabsorbable in the mammalian body. This makes it especially suitable for use in conjunction with surgical stapling procedures, especially in endoscopic surgery. The  
30 rate of bioabsorption of the biopolymer can be controlled by cross-linking the biopolymer.

The biopolymer sponge tubes preferably have



substantially uniform internal and external cross-sections. Preferably, the wall thickness of the tubes is also substantially constant. Preferably, the internal and external cross-sections are both substantially circular or  
5 rectangular. Preferably, the average internal diameter of the biopolymer sponge tubes is from 3mm to 30mm, or preferably 5mm to 20mm, and the wall of the biopolymer sponge tube has a substantially uniform uncompressed wall thickness in the range of 1 to 4mm. Preferably, the ratio of the  
10 length to the average external diameter of the biopolymer sponge tubes is in the range of 2:1 to 10:1, preferably 3:1 to 5:1. These preferred shapes and dimensions are especially suitable for fitting the biopolymer sponge tube over one or other barrel of a surgical stapler.

15

The biopolymer sponge tubes are preferably prepared by a process comprising:

providing an aqueous dispersion of the biopolymer;

20

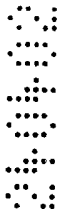
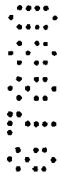

introducing the dispersion into a tube-shaped mould, following by freezing the dispersion to provide a shaped frozen dispersion; and freeze-drying or solvent-drying the shaped frozen dispersion to form the biopolymer sponge tube.

5

Preferably, the aqueous dispersion comprises 0.05-2.5% w/v of the biopolymer. The aqueous dispersion may be buffered to an optimum pH, and may also comprise therapeutic active agents for incorporation into the final biopolymer sponge tube. The aqueous dispersion may also contain emulsified lipid droplets for incorporation into the biopolymer sponge tube, as described and claimed in our patent application EP-A-0567234, the entire content of which is incorporated herein by reference.

10

15

A chemical cross-linking agent, such as glutaraldehyde or hexamethylene diisocyanate (HMDI) may be incorporated in the aqueous dispersion, or may be used to treat the biopolymer sponge tube following the drying step.

20

The tube-shaped mould is preferably in the shape of a tube closed at one end. If it is intended that the final biopolymer sponge tube should be reinforced with a bioabsorbable mesh, such as a Vicryl (registered trade mark) polylactide-polyglycolide mesh, then the mesh is inserted into the mould with the aqueous dispersion prior to freezing.

25

Preferably, the frozen aqueous dispersion is removed from the mould prior to drying. This can be achieved by warming the mould slightly and inverting the mould to allow the frozen aqueous dispersion to drop from the mould. Preferably, the central part of the mould defining the inside wall of the tubular frozen aqueous dispersion can be warmed and removed from the mould automatically. More preferably, the end (i.e. base wall) of the mould is moveable in piston fashion along the length of the mould to expel the frozen aqueous dispersion from the mould.

30

35

Preferably, an array of tube-shaped moulds is provided for simultaneous moulding and freezing of a plurality of frozen aqueous dispersions. More preferably, the steps of pouring the aqueous dispersion into the mould, freezing, and expelling the frozen aqueous dispersion from the mould are alternated.

The shaped frozen dispersion is freeze-dried or solvent-dried to form the biopolymer sponge tube. Freeze-drying is typically carried out at  $-10^{\circ}\text{C}$  to  $+20^{\circ}\text{C}$  overnight. Solvent-drying is preferably carried out in a succession of baths of anhydrous isopropyl alcohol as described in US-A-3157524, the entire content of which is expressly incorporated herein by reference.

The dried biopolymer sponge tube is preferably packaged in aseptic packaging, and then dry sterilised, preferably by gamma-irradiation.

Specific embodiments of the present invention will now be described further, by way of example, with reference to the accompanying drawings, in which:-

Figures 1(a)-1(d) shows schematic cross-sectional views of stages in a process for preparing an open-ended biopolymer sponge tube;

Figures 2(a)-2(d) shows schematic cross-sectional views of stages in a process for preparing a biopolymer sponge tube closed at one end according to the present invention;

Figure 3 shows schematic top-plan view (a) and cross-sectional views (b)-(d) of stages in a process similar to that of Figure 2, but adapted for automated production of multiple biopolymer sponge tubes closed at one end;

Figure 4 shows a schematic side view of a surgical staple gun; and

Figure 5 shows the staple gun of Figure 4 fitted with biopolymer sponge tubes according to the invention.

Procedure 1: Preparation of open-ended Fibrous Collagen  
Sponge Tubes

5 Lyophilised collagen is prepared as described in US patents nos. 4614794 or 4320201, the entire contents of which are expressly incorporated herein by reference. The lyophilised collagen is re-suspended in cold 0.05M acetic acid at a concentration of 1% w/v. The pH is adjusted to 3.0 with acetic acid. The resulting slurry is poured into a cylindrical mould 1 as shown in cross-section in Figure 1(a). The mould with the slurry 2 therein is frozen at -40°C as shown in Figure 1(b). The frozen slurry is removed from the mould by slightly warming the mould, and inverting the mould to allow the tube to slip from the mould as shown in Figure 1(c). The frozen tube 3 is transferred immediately to a freeze-dryer and freeze-dried to form a collagen sponge tube 4.

20 The resulting freeze-dried collagen tube is soft and conformable, bioabsorbable, and also exhibits useful haemostatic properties when applied with a surgical stapler.

Procedure 2: Preparation of Soluble Collagen Sponge Tube

25 The procedure described above in Procedure 1 is repeated, replacing the fibrous lyophilised collagen by pepsin-solubilised collagen at a concentration of 10mg/ml. The resulting sponge tube is water soluble.

Procedure 3: Preparation of cross-linked Collagen Sponge Tube

30 The procedure of Procedure 1 is repeated, but with cross-linking of the collagen in the aqueous slurry. The lyophilised collagen as in Procedure 1 is resuspended in 0.05M acetic acid at a concentration of 1%w/v. The pH is adjusted to 3.0. Hexamethylene diisocyanate (HMDI) is added at 2%w/w collagen and homogenised in a Waring Blendor (3 x

30s). The resulting slurry is formed into collagen sponge tubes exactly as described in Procedure 1.

Procedure 4: Preparation of Gelatin Sponge Tube

5 The fibrous collagen slurry prepared as in Procedure 1 is gelatinised by heating to 60°C for one hour. The slurry is then processed into a biopolymer sponge tube as in Example 1.

Procedure 5: Preparation of Collagen/ORC Sponge Tubes.

10 Lyophilised collagen, prepared as described in US Patent No. 4614794 or 4320201, is resuspended in cold 0.05M acetic acid at a concentration of 10mg/ml. Milled ORC powder (milled SURGICEL® cloth) is added to the suspension in a ration of 1:3 ORC: collagen and homogenised using a Waring  
15 Blendor on low speed for 3 x 10s. The slurry is degassed in a vacuum oven for 10min and then poured into the appropriate mould. The mould with the slurry is then processed as described in Procedure 1.

Example 1: Preparation of Biopolymer Sponge Tubes with

20 Closed End

Biopolymer sponge tubes closed at one end are prepared as shown in schematic cross-section in Figure 2. A biopolymer slurry as described in Procedures 1-6 is poured into a mould in the shape of a closed-end tube and formed  
25 from an outer shell and a central mandrel 6. The slurry and mould are frozen at -40°C. The central mandrel 6 of the mould is warmed slightly and removed from the inside of the cast open-ended tube 7. The outer shell 5 of the mould is then inverted and warmed slightly to release the frozen  
30 slurry in the shape of a tube closed at one end 7. The cast, frozen tube is then immediately freeze-dried to give a biopolymer sponge tube closed at one end 8.

Example 2: Multiple Moulding of Biopolymer Sponge Tubes

35 Figure 3 shows an apparatus 10 for the multiple, automated production of biopolymer sponge tubes closed at one end. The apparatus comprises an array of wells 11 defining the outer parts of the moulds, and a complementary

array of mould mandrels 12 for insertion into the wells. The floor 13 of each mould well is mounted on a piston 14, and is slideably moveable inside the well 11 to push the frozen, cast tubes 15 out of the wells following the casting and freezing steps. The frozen tubes 15 are collected and freeze-dried.

Example 3: Use of Biopolymer Sponge Tubes on Surgical Stapler

10 Figure 3 shows a schematic view of a surgical staple gun 20 for use in lung volume reduction surgery. The staple gun is provided with a stapler cartridge barrel 21 and an anvil barrel 22. In use, biopolymer sponges tube 23,24 having a closed end are slipped over the end of each of the cartridge 15 barrel 21 and the anvil barrel 22 as shown in Figure 5.

The two barrels 21,22 of the staple gun 20, with the biopolymer sponge tubes 23,24 in place, are then placed on either side of the tissue that requires sealing. The 20 stapling action brings together with two barrels whilst the tubes, which flatten during the stapling procedure, are stapled into position at the appropriate site. The flattened biopolymer tubes then act as a seal to prevent exudate/air leakage, and where appropriate to encourage 25 haemostasis.

The above embodiments have been described by way of example only. Many other embodiments falling within the scope of the accompanying claims will be apparent to the 30 skilled reader.

The claims defining the invention are as follows:

1. A method for producing biopolymer sponges comprising the steps of:
  - 5 (f) providing an aqueous dispersion of the biopolymer;
  - (g) introducing the dispersion into a mold;
  - (h) freezing the dispersion to provide a shaped frozen dispersion;
  - (i) heating the mold and releasing the shaped frozen
  - 10 dispersion from the mold; and
  - (j) drying the released frozen dispersion.
  
2. A method according to claim 1, wherein the mold is a mold for making tubes.
  
- 15 3. A method according to claim 2, wherein the mold comprises an outer cylindrical shell having a distal closed end and proximal opened end, a central block being disposed within the shell and resting on the distal closed end of the shell, whereby the block and shell form an annular space
- 20 therebetween.
  
4. A method according to claim 3, wherein the heating step
- 25 (d) involves heating the central block.
  
5. A method according to claim 3, wherein the heating step
- (d) involves heating the outer cylindrical shell.
  
6. A method according to claim 2, wherein the mold
- 30 comprises an outer cylindrical shell having a distal closed end and a proximal opened end, a mandrel for insertion into the shell, whereby the shell and the mandrel define an annular space along the longitudinal dimension of the shell



and mandrel and define an open area between the base of the mandrel and the distal closed end of the shell, the open area contiguous with the annular space when the mandrel is placed in the shell.

5

7. A method according to claim 6, wherein the heating step (d) involves heating the mandrel.

8. A method according to claim 6, wherein the heating step (d) involves heating the outer cylindrical shell.

10

9. A method according to claim 2, wherein the mold comprises a cylindrical outer shell opened at both the distal and proximal ends, a mandrel, and a piston, whereby the shell and the mandrel define an annular space along the longitudinal dimensions of the shell and mandrel, the piston insertable into and through the distal end of the shell, the piston and base of the mandrel defining an open space therebetween, the open space being contiguous with the annular space between the mandrel and the shell.

15

20

10. A method according to claim 9, wherein the heating step (d) involves heating the mandrel.

11. A method according to claim 9, wherein the heating step (d) involves heating the shell.

25

12. A method according to claim 9, wherein the heating step (d) involves heating the piston.

30

13. A method according to claim 2, wherein the mold comprises an array of wells defining the outer parts of the mold, a complimentary array of mold mandrels for insertion

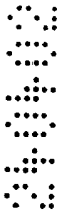

into the wells, wherein the floor of each mold well is mounted on a piston which is slideably moveable inside the well to push the frozen dispersion out of the wells.

5 14. A method according to claim 13, wherein the heating step (d) involves heating the mandrels.

15. A method according to claim 13, wherein the heating step (d) involves heating the array of wells.

10

16. A method according to claim 13, wherein the heating step (d) involves heating the pistons.

15 17. A method for producing biopolymer sponges comprising steps substantially as hereinbefore described.

Dated: 24 April, 2002

**FREEHILLS CARTER SMITH BEADLE**

Patent Attorneys for the Applicant

JOHNSTON & JOHNSON MEDICAL LIMITED

20



02 10 38 0100

FIG. 1(a)

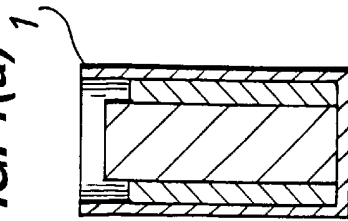

FIG. 1(b)

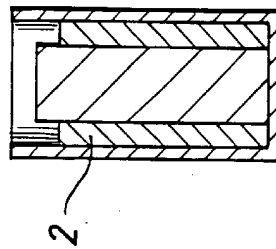

FIG. 1(c)

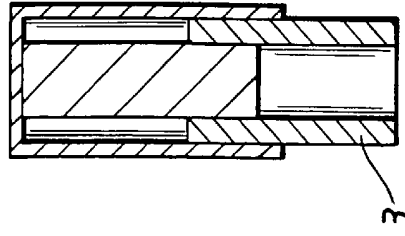
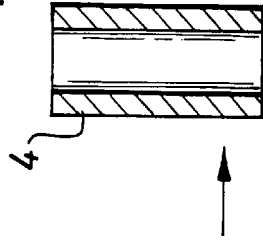
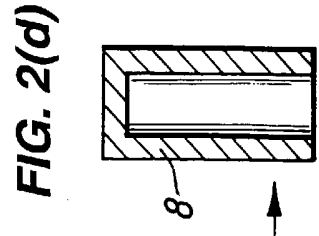
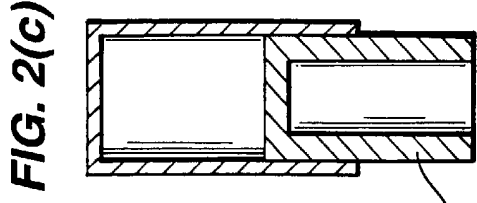
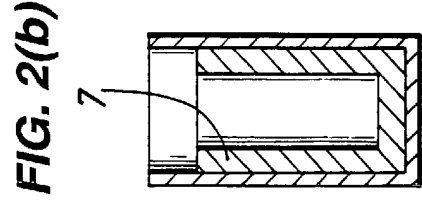
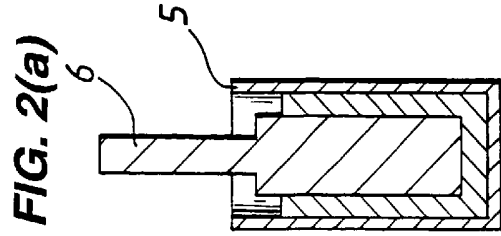

FIG. 1(d)



US 10 382 000 B2



02 10 38 81000

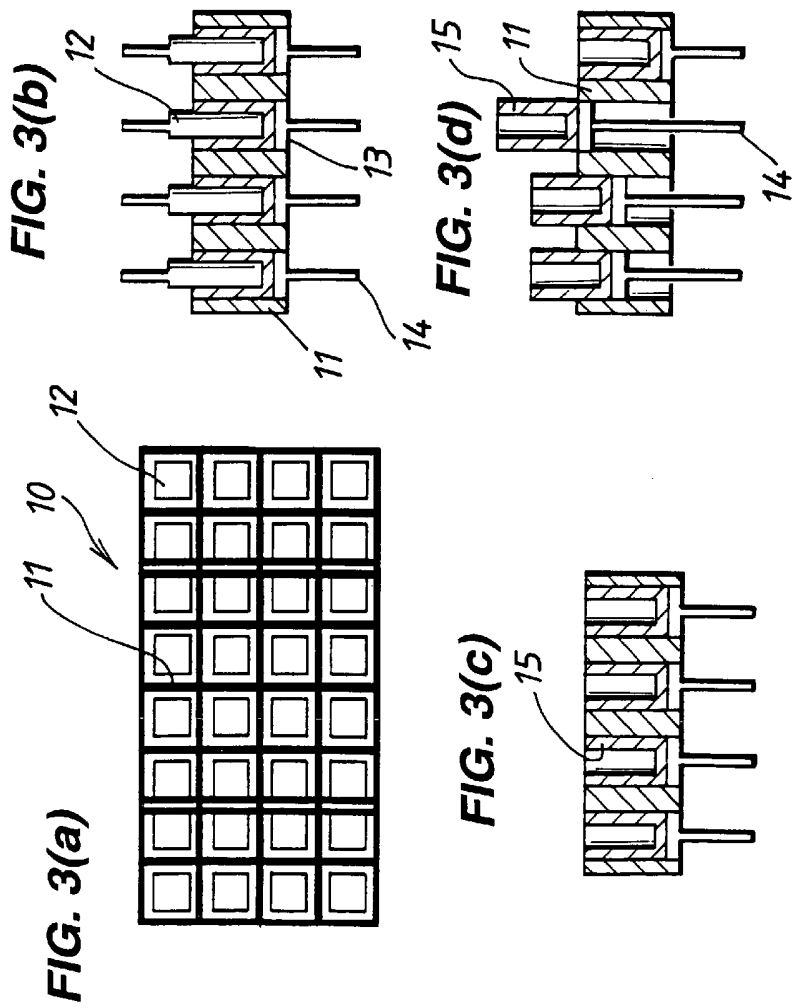

**FIG. 4**

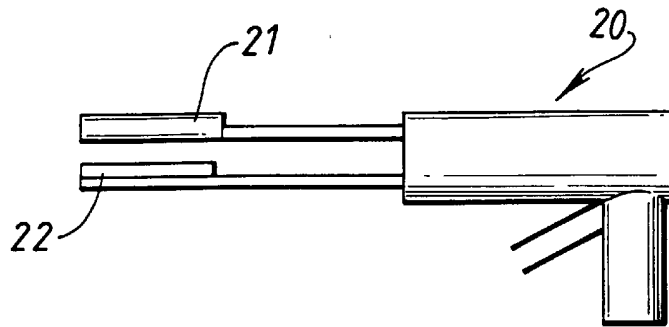

**FIG. 5**

