

(No Model.)

4 Sheets—Sheet 1.

H. CAMPBELL.  
STRAW STACKER.

No. 301,044.

Patented June 24, 1884.

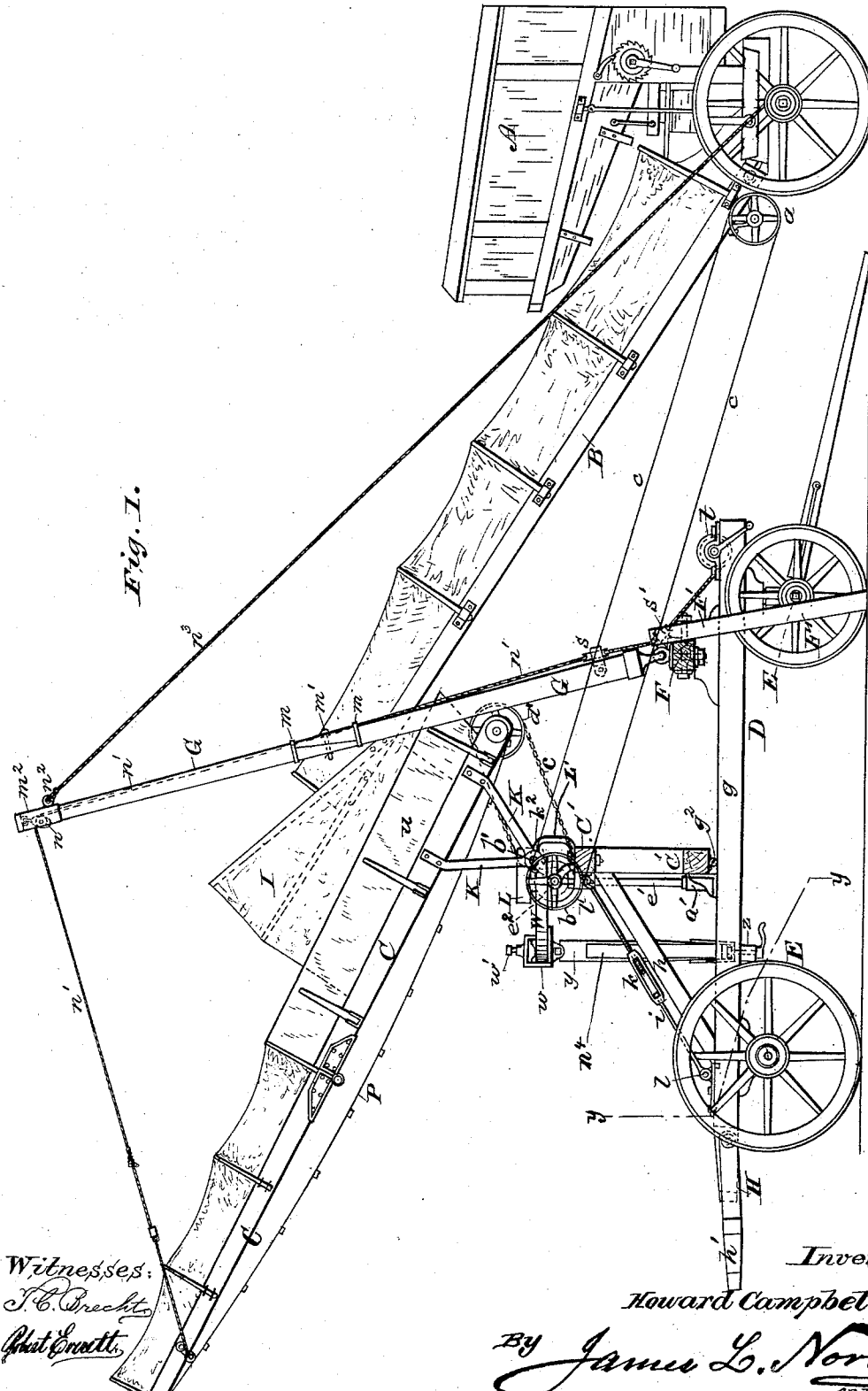

Fig. 1.

Witnesses:  
*J. C. Brecht*  
*Chas. Everett*

Inventor  
*Howard Campbell.*

By *James L. Norris,*  
Attorney.





(No Model.)

4 Sheets—Sheet 4.

H. CAMPBELL.  
STRAW STACKER.

No. 301,044.

Patented June 24, 1884.

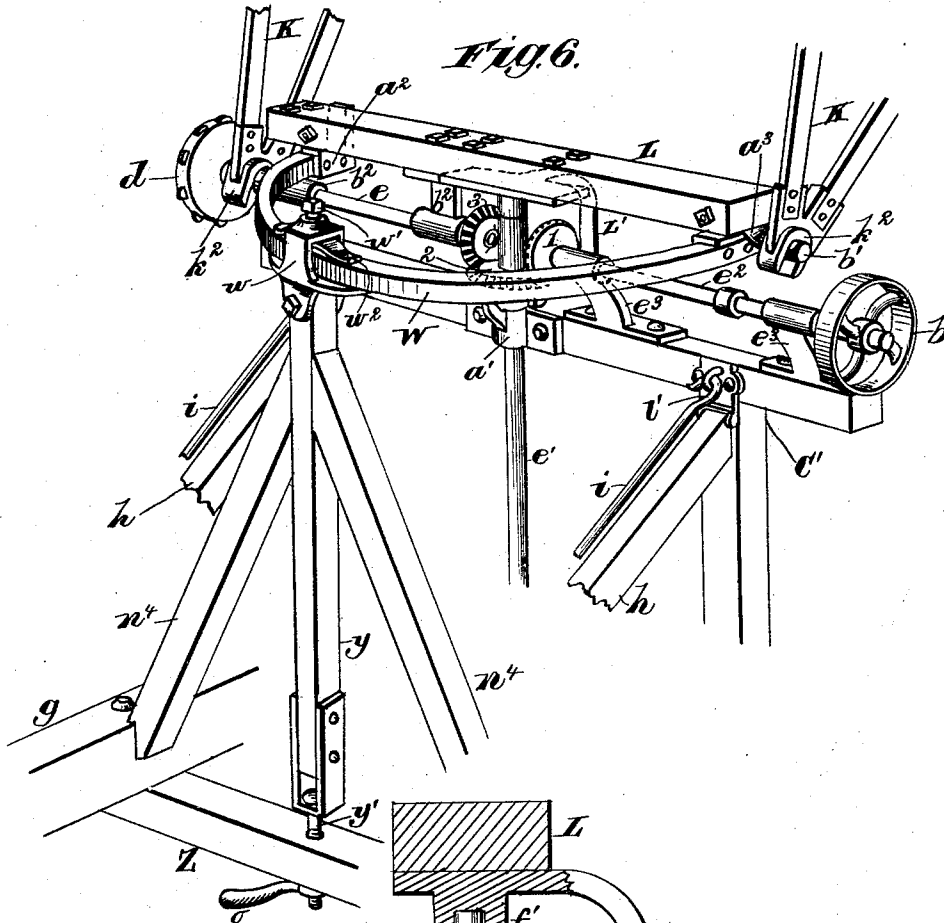
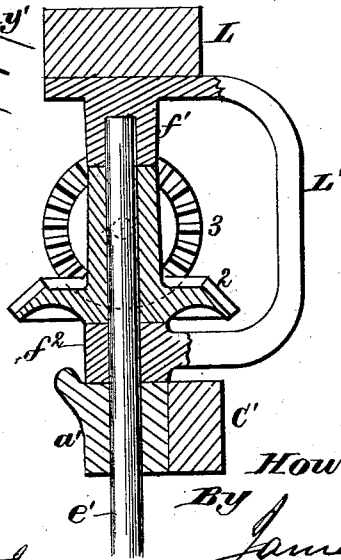

Fig. 7.



Witnesses.

Robert Emmett,

J. A. Rutherford

Inventor.

Howard Campbell.

By

James L. Norris,

Atty.

# UNITED STATES PATENT OFFICE.

HOWARD CAMPBELL, OF RICHMOND, INDIANA, ASSIGNOR TO GAAR, SCOTT & COMPANY, OF SAME PLACE.

## STRAW-STACKER.

SPECIFICATION forming part of Letters Patent No. 301,044, dated June 24, 1884.

Application filed March 6, 1884. (No model.)

*To all whom it may concern:*

Be it known that I, HOWARD CAMPBELL, a citizen of the United States, residing at Richmond, in the county of Wayne and State of Indiana, have invented new and useful Improvements in Straw-Stackers, of which the following is a specification.

This invention relates to improvements in that class of straw-stackers which are used in connection with a thrashing or separating machine, and have an elevator upon which the straw is delivered and carried to any desired point of the stack; and the objects of the invention are to provide novel means for supporting a straw-elevator and angularly adjusting it in relation to the usual straw-carrier of a thrashing-machine or grain-separator; to produce a straw-stacker which can be readily transported to the desired place, set up, and connected with the separator with comparatively little trouble, and easily taken down and folded for transportation; and to provide a novel derrick-frame and means for securely holding it in position, to prevent it from falling or being blown over by the wind. These objects I accomplish by the construction and combination of devices hereinafter described and claimed, reference being had to the accompanying drawings, in which—

Figure 1 represents a side elevation of the improved straw-stacker in position. Fig. 2 is a partially-sectional view of the same, taken on the line *yy*. Fig. 3 is a view showing the parts folded for transportation. Fig. 4 are detail views of the lower part of the derrick-frame. Fig. 5 is a detail view of the upper part of the derrick-frame. Fig. 6 is detached view of the devices for adjusting the elevator angularly to the separator, showing also portions of the hinged frame and gearing for driving the elevator-apron; and Fig. 7, a detail vertical sectional view.

In the drawings, *A* designates the rear end portion of a thrashing-machine or grain-separator, and the ordinary straw-carrier, *B*, of any required length and size, attached thereto, by which the straw is conveyed to the straw-elevator *C*, which is provided with the usual endless apron or carrier, *P*, having attached cross-bars for elevating the straw to the stack.

The apron is operated by pulleys or sprocket-wheels *a b d d'* and belts or chains *c c* from a portable engine or other motive power. The pulley *b* is secured to the outer end of a horizontal shaft, *e'*, journaled in bearings *e'*, attached to the top cross-piece of a swinging frame, *C*, and provided at its inner end with a bevel-gear wheel, 1, meshing with a bevel-pinion, 2, secured to the upper end of a vertical shaft, *e'*, journaled in bearings *a'* on the top and bottom cross-pieces of the hinged frame. In a loop-bracket, *w*, fixed in the upper end of a standard, *y*, is arranged a semi-circular iron support, *W*, the extremities of which are connected by bolts with the ends of a cross-beam, *L*, through the medium of brackets *a' a'*, the bracket *a'* being provided with a laterally-projecting pivot-pin, *b'*; and to the under side of the cross-beam *L* are secured pendent bearings *b'*, in which is journaled a horizontal shaft, *e*, having at its outer end the pulley *d* and at its inner end the bevel-gear wheel 3, meshing with the pinion 2 on the upper end of the shaft *e'*.

To the cross-beam *L*, centrally between its ends, is firmly attached one end of a yoke, *L'*, such end having a socket-bearing, *f'*, for the upper end of the vertical shaft *e'*, the other end of the yoke being provided with an eye-bearing, *f'*, in line with and resting on the upper bearing, *a'*, of the vertical shaft, whereby the cross-beam *L* and extremities of the circular support *W* are sustained in proper position, while the said support and attached beam can be adjusted around in a circular path, the axis being the shaft *e'*, and the circular support moving and guided in the loop-bracket *w* of the standard *y*, which sustains the circular support. A bow-spring, *w'*, is arranged in the loop-bracket, to bear at its ends in frictional contact with the upper surface of the circular support, and the pressure of the spring can be changed by the adjusting-screw *w'*, so that the circular support can be held stationary in any desired position, the spring and the screw constituting a simple and efficient brake for such purpose. The vertical standard is held in its upright position by a threaded extension, *y'*, at its lower end passing through a cross-beam, *Z*, resting against the under sides of the side sills,

such threaded extension engaging a threaded socket in a hand-lever, *o*, or similar device; and to steady and aid in supporting the standard it is provided with attached inclined braces *n*<sup>4</sup>, notched at their lower ends to bear on the side sills, so that the braces and standard are firmly but detachably connected with or clamped upon the side sills of the wagon-frame.

The lower end of the straw-elevator is provided at each side with a pendent bracket, *K*, having a forked or open bearing, *k*<sup>2</sup>, at its extremity, one of such bearings resting upon the horizontal shaft *e* and the other upon the pivot-pin *b*<sup>1</sup>, so that the elevator can be raised and lowered on the pivotal bearings, which are composed of the outer end of the horizontal shaft *e* and the pin *b*<sup>1</sup> on the bracket *a*<sup>3</sup>. By moving the circular support *W* back and forth in a circular path in the loop-bracket *w*<sup>2</sup>, the cross-beam *L* and the straw-elevator will partake of its movements, and therefore the elevator can be swung around to any desired angular position relatively to the carrier *B*, for depositing the straw at any point or any place on the stack being formed; and in such movements of the elevator the gear-wheel on the inner end of the shaft *e* will rotate on the pinion *2* by reason of the said shaft being carried by bearings on the cross-beam. The belts *c c* serve to drive the pulleys *a*, *b*, *d*, and *d'*, as stated, and hence the apron *P* and straw-carrier *B* will be caused to move in the same direction.

The swinging frame *C'* is shown hinged at *g*<sup>2</sup> to the side sills, *g*, of the main frame *D*, which latter is attached to bolsters of the truck or wagon axles *E*, and the swinging frame is held in its upright position by means of braces *h h* and iron rods *i i*, each of the latter being composed of two sections connected by a turn-buckle or swivel, *k*, by which the sections can be adjusted lengthwise. The rods, at their lower ends, are attached to eyebolts *l* on the side sills, *g*, and their upper ends have hooks *l'*, which engage with eyebolts on the hinged frame *C'*, so that when the turn-buckles or swivels *k* are disconnected the hinged frame and its concomitants can be folded down, as shown in Fig. 3, it of course being necessary to detach the cross-beam *Z* and standard *y* from their connection with the side sills of the truck-wagon frame.

Near the front of the truck is firmly attached a cross-bar, *F*, to which the lower ends or sections of the derrick-frame *G* are hinged or pivoted, and at the opposite end of said truck is placed a hinged support, *H*, having two forked uprights, *h'*—one at each side—between which forks the upper ends of the derrick-frame are supported when the stacker is to be transported or moved to another place.

The derrick-frame is composed of two sections, the lower section being simply limbs jointed to the front cross-bar, *F*, while the upper section is composed of two limbs jointed at the outer ends by a cap-piece, *m*<sup>2</sup>. The two

sections of the derrick-frame are connected together and secured by iron bands or ferrules *m* and transverse pins *m'*, and to the center of the cap-piece *m*<sup>2</sup> of the upper section is attached a swivel-block, *n*, over which the rope *n'*, attached to the outer end of the elevator passes, and by which it is raised or lowered, as required. The rope *n'* passes over the two sheaves *s* and *s'* at the lower end of the derrick-frame onto a windlass, *t*, journaled in the side sills of the truck, and when said windlass is operated the stacker is raised or lowered to the position or height desired.

To the upper end of the derrick-frame are secured the eyebolts *n*<sup>2</sup>, to which the guy-ropes *n*<sup>3</sup>, that support the derrick-frame, are attached and extend to the thrashing-machine or separator.

To the outer ends of the cross-bar *F* are bolted two uprights or standards, *F'*, which, when the stacker is in use, rest on the ground, so that the derrick thereby receives a broader and firmer base or foundation to steady it.

The straw-elevator is made in two sections, *C C*, which are hinged together, so that they can be folded on each other for transportation, and have on each side a guard or apron of canvas or other suitable material, to prevent the wind from scattering the straw while being conveyed up by the elevator-apron *P*. At the point where the straw is delivered from the straw-carrier *B* of the thrashing-machine to the elevator is arranged a hood, *I*, of canvas or other flexible material, so as to prevent the wind from scattering the straw at that point. The lower or forward end of the straw-elevator is provided with side pieces or guards, *u*, so that this part is also protected against the wind, and the entire length of the elevator is thereby protected.

The standard *F'* can be readily detached and carried in some suitable manner, and the other concomitants of the straw-stacker can be conveniently brought to the position shown in Fig. 3 for transportation.

Having thus described my invention, what I claim is—

1. The combination, in a stacker, of a wheeled frame, a vertical standard, a circular support adjustable around on the standard, a cross-beam on the support, a sustaining-axis for the support and cross-beam, a brake for holding the support in its adjusted position, and a swinging straw-elevator, substantially as described.

2. The combination, in a stacker, of a wheeled frame, a vertical beam detachably held on the frame, and provided at its upper end with a loop-bracket, a circular support held by and adjustable around within the bracket, pivot-bearings at the ends of the circular support, and a swinging elevator detachably pivoted on the pivot-bearings, substantially as described.

3. The combination, in a straw-stacker, of a wheeled frame, a vertical beam detachably

supported by the frame and provided at its upper end with a loop-bracket, a circular support held by and adjustable around within the bracket, a spring-brake acting on the circular support, a set-screw for adjusting the tension of the brake, pivot-bearings at the ends of the circular support, and an elevator having brackets at its lower end detachably pivoted on the pivot-bearings, substantially as described.

4. The combination, with a wheeled frame, of the vertical beam *y*, having the threaded extension at its lower end, the braces *n*<sup>1</sup>, the cross-beam *Z*, the lever *o*, the circular support *W*, adjustable around on the vertical beam, and provided at its ends with pivot-bearings, and the elevator detachably pivoted on the pivot-bearings, substantially as described.

5. The combination, with a wheeled frame, of the vertical beam *y*, having a threaded extension at its lower end, the braces *n*<sup>1</sup>, the cross-beam *Z*, the lever *o*, the loop-bracket *w* on the upper end of the vertical beam, the circular support adjustable around in the loop-bracket, the pivots *p* on the said support, the elevator detachably pivoted on the pivots, the set-screw *w*<sup>1</sup>, and the spring *w*<sup>2</sup>, substantially as described.

6. The combination, with a wheeled frame and a straw-elevator having brackets *K*, provided with open bearings *k*<sup>2</sup>, of the frame *C*<sup>1</sup>, hinged to the wheeled frame, cross-beam *L*, horizontal shafts *e* *e*<sup>2</sup>, journaled on the hinged frame and the cross-beam, respectively, and pivot-pin *b*<sup>1</sup>, substantially as described.

7. The combination, with a wheeled frame and a pivoted straw-elevator, of a swinging frame, *C*<sup>1</sup>, on the wheeled frame, a cross-beam, *L*, geared shafts carried by the hinged frame and the cross-beam, respectively, for transmitting motion to the apron of the elevator, braces *h*, bearing against the swinging and the wheeled frames, and rods *i* *i*, adjustable lengthwise for sustaining the swinging frame in its upright position, substantially as described.

8. The combination, in a straw-stacker, of a wheeled frame, a cross-bar, *F*, thereon, a folding derrick-frame, *G*, pivoted to the cross-bar, and the supports *H*, hinged to the wheeled frame at its rear end, substantially as described.

9. The combination, in a straw-stacker, of a wheeled frame, a cross-bar, *F*, thereon at the

front end, a sectional folding derrick-frame, *G*, supported by the wheeled frame, and supports *H*, pivoted to the rear of the wheeled frame, and provided with forked ends *h*<sup>1</sup>, substantially as described.

10. The combination, in a straw-stacker, of a wheeled frame, a cross-bar, *F*, thereon, a derrick-frame pivoted to the cross-bar, detachable legs *F*<sup>1</sup>, connected with the cross-bar, and the carrier *B*, substantially as described.

11. The combination of a truck-frame, an elevator, a frame hinged to the truck-frame, a circular support, a standard detachably connected with the truck-frame for sustaining the circular support, and pivot-bearings for the elevator, substantially as described.

12. The combination of a truck-frame, a frame hinged thereto, a standard detachably connected with the frame, a circular support connected with the upper ends of the hinged frame and standard, and a pivoted straw-elevator, substantially as described.

13. The combination of a truck-frame, a frame hinged thereto, a vertical shaft on the hinged frame, a circular support, a standard sustaining the latter, a cross-beam, a supporting-connection between the beam and the shaft, and horizontal shafts geared to the vertical shaft on the hinged frame, substantially as described.

14. The combination of a truck-frame, a frame hinged thereto, a vertical shaft on the hinged frame, a standard sustained by the truck-frame, a support at the upper end of the standard, a cross-beam on the support, a connection between the cross-beam and the vertical shaft, and a pivoted straw-elevator, substantially as described.

15. The combination of a truck-frame, a frame hinged thereto, a vertical shaft on the hinged frame, a standard sustained by the truck-frame, a circular support adjustable in a circular path on the standard, a cross-beam on the circular support, a supporting-connection between the beam and the vertical shaft, a swinging straw-elevator, and pivot-bearings therefor, substantially as described.

In testimony whereof I have hereunto set my hand in the presence of two subscribing witnesses.

HOWARD CAMPBELL.

Witnesses:

E. H. DENNIS,  
GEO. P. EARLEY.