

(No Model.)

4 Sheets—Sheet 1.

J. B. LAWTON & J. A. MERGENTHAL.
MACHINE FOR COMPRESSING AND STAMPING SOAP.

No. 448,656.

Patented Mar. 24, 1891.

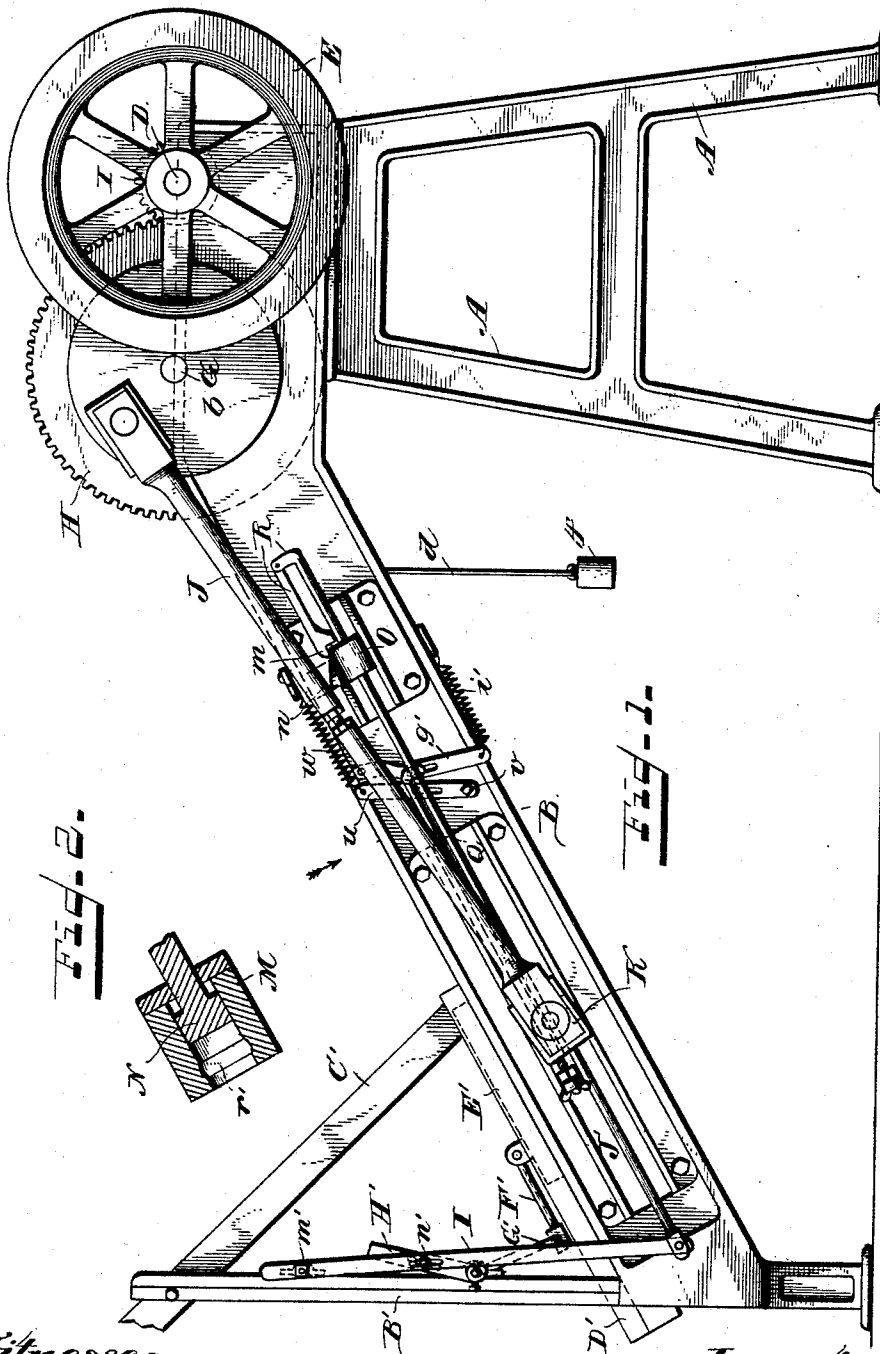

Witnesses.
J. Thomson Cross
E. S. Houtworth

Inventor.
Jas. B. Lawton &
John A. Mergenthal
per *Peck & Victor*
their Attorneys.

(No Model.)

4 Sheets—Sheet 2.

J. B. LAWTON & J. A. MERGENTHAL.
MACHINE FOR COMPRESSING AND STAMPING SOAP.

No. 448,656.

Patented Mar. 24, 1891.

FIG. 3.

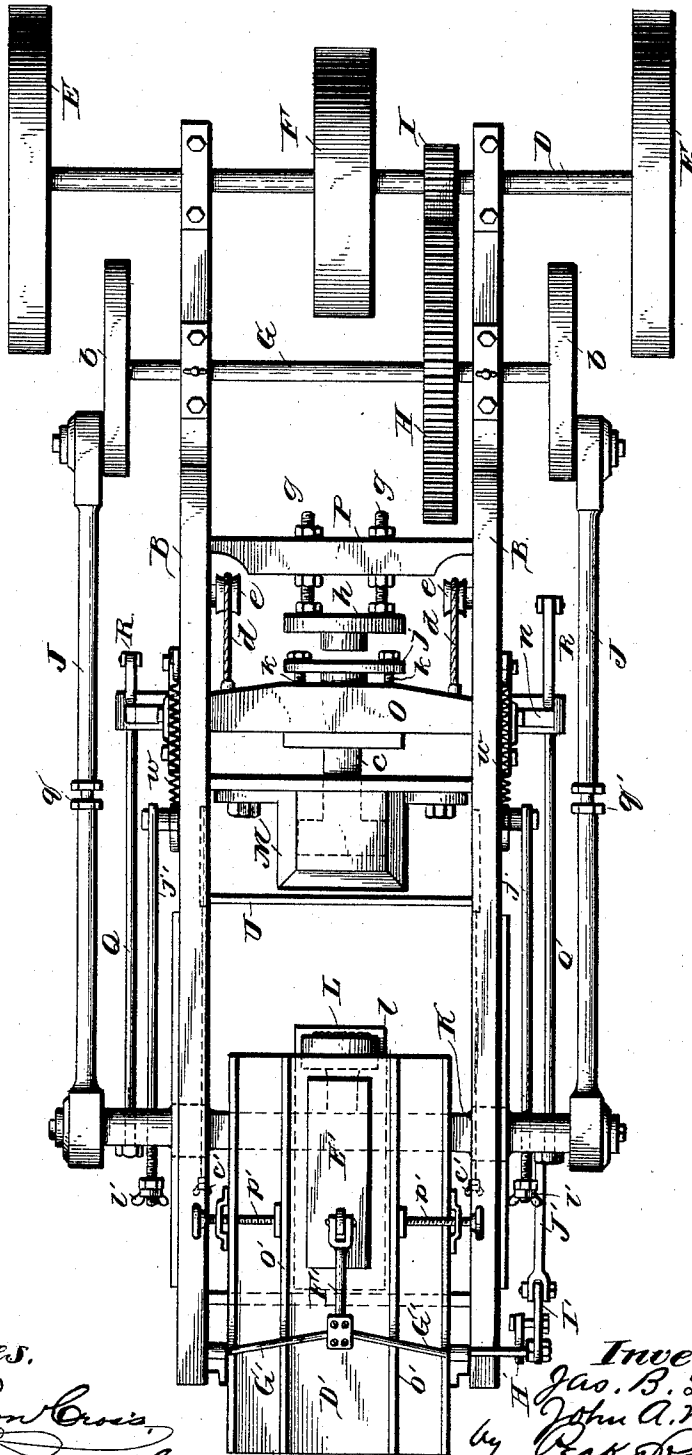

Witnesses,
Thomson Criss,
G. S. Wentworth

Inventor
Geo. B. Lawton &
John A. Mergenthal
 by *Peck & Pector*
 their Attorneys.

(No Model.)

4 Sheets—Sheet 3.

J. B. LAWTON & J. A. MERGENTHAL.
MACHINE FOR COMPRESSING AND STAMPING SOAP.

No. 448,656.

Patented Mar. 24, 1891.

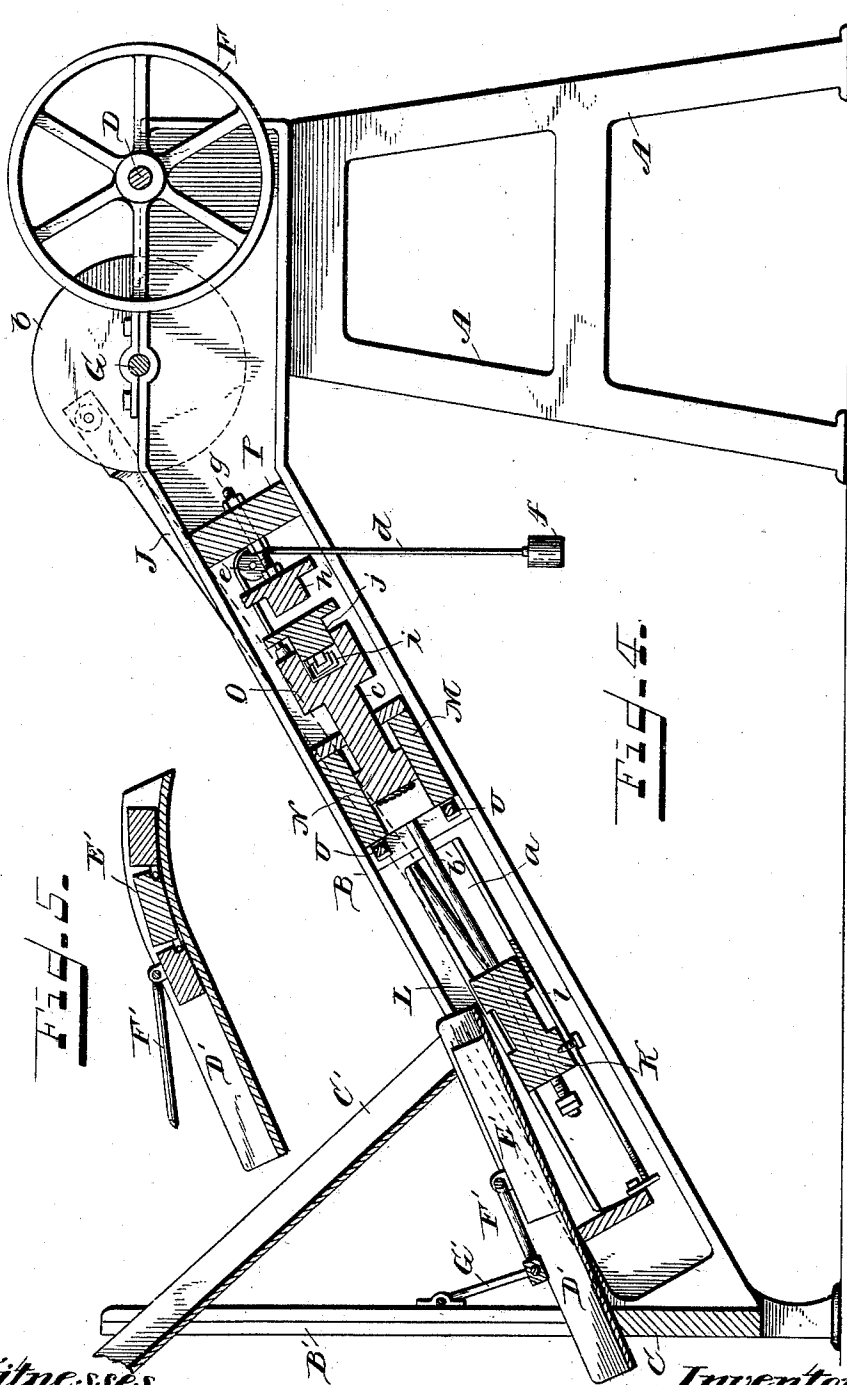

Witnesses.
Thomson Cross
A. S. Newthworth

Inventors.
Geo. B. Lawton and
John A. Mergenthal
 per *Peck & Decker*
 their Attorneys.

(No Model.)

4 Sheets—Sheet 4.

J. B. LAWTON & J. A. MERGENTHAL.
MACHINE FOR COMPRESSING AND STAMPING SOAP.

No. 448,656.

Patented Mar. 24, 1891.

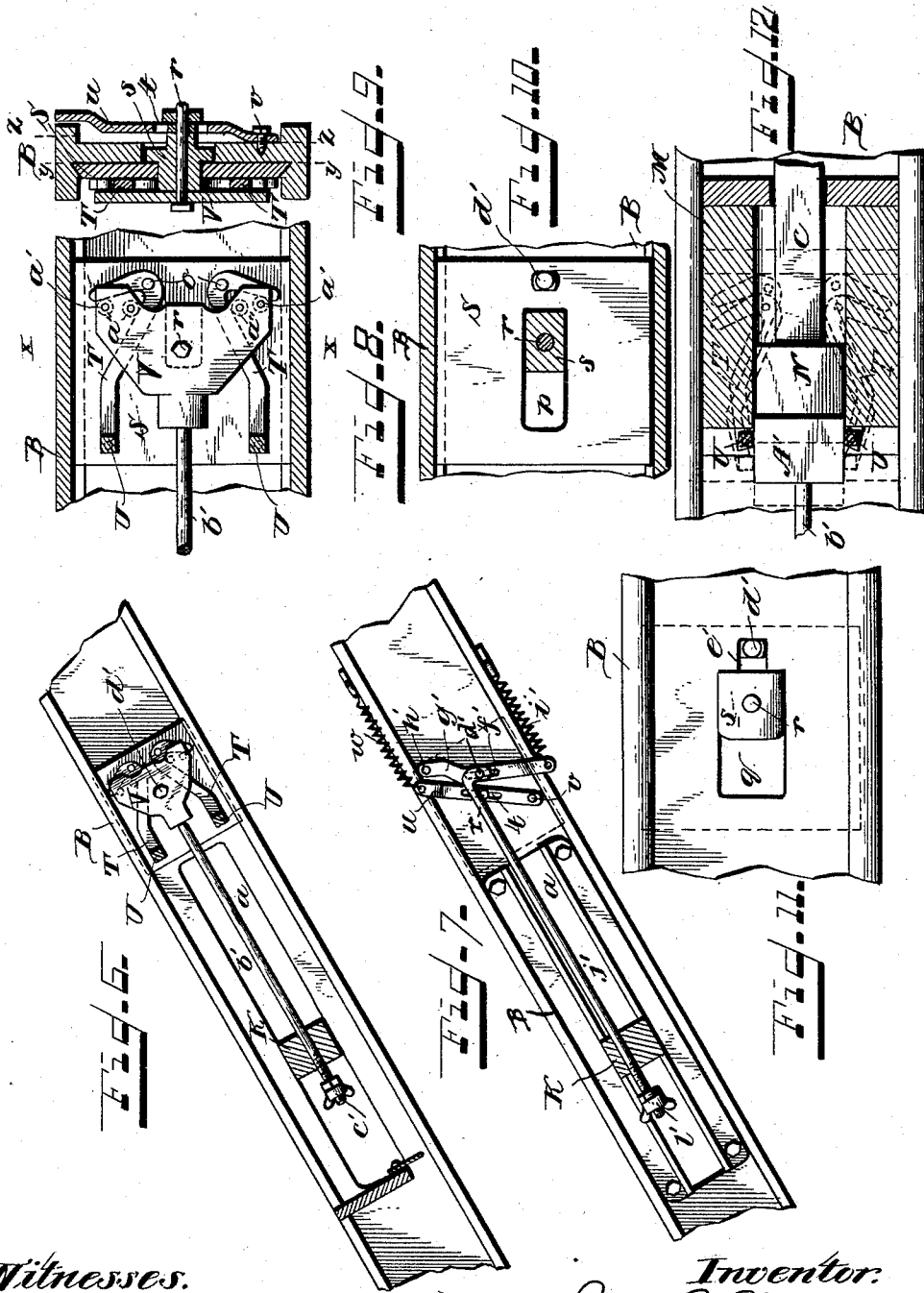

Witnesses.

Thomas Cross
Wentworth

Inventor:
Geo. B. Lawton &
John A. Mergenthal
per *Geo. Rector*
their Attorneys.

UNITED STATES PATENT OFFICE.

JAMES B. LAWTON, OF CINCINNATI, OHIO, AND JOHN A. MERGENTHAL, OF NEWPORT, KENTUCKY; SAID MERGENTHAL ASSIGNOR TO SAID LAWTON.

MACHINE FOR COMPRESSING AND STAMPING SOAP.

SPECIFICATION forming part of Letters Patent No. 448,656, dated March 24, 1891.

Application filed December 9, 1890. Serial No. 374,025. (No model.)

To all whom it may concern:

Be it known that we, JAMES B. LAWTON, residing at Cincinnati, in the county of Hamilton and State of Ohio, and JOHN A. MERGENTHAL, residing at Newport, in the county of Campbell and State of Kentucky, both citizens of the United States, have jointly invented certain new and useful Improvements in Machines for Compressing and Stamping Soap, of which the following is a full, clear, and exact description, reference being had to the accompanying drawings, forming part of this specification.

Our invention relates to machines for giving cakes of soap their final shape and ornamentation, including trade names or marks; and it has for its object the improved construction of such machines by which their efficiency and simplicity are increased and the danger to employes who operate them lessened.

The novelty of our invention will be hereinafter set forth and specifically pointed out in the claims.

In the accompanying drawings, Figure 1, Sheet 1, is a side elevation of a machine embodying our invention. Fig. 2, Sheet 1, is a sectional detail of the compress box under a modified form and the upper die contained therein. Fig. 3, Sheet 2, is a plan view of the machine, looking in the direction of the arrow, Fig. 1, and with the feed-trough removed. Fig. 4, Sheet 3, is a central sectional side elevation of the machine. Fig. 5, Sheet 3, is a sectional detail representing a modification in the construction of the feeding-plunger. Fig. 6, Sheet 4, is a detail, partly in section, of the inclined side guide-bar and the operating mechanism for the soap gripping and removing jaws, looking at the same from the inside. Fig. 7, Sheet 4, is a corresponding view looking at the same from the outside. Fig. 8, Sheet 4, is an enlarged inside view, partly in section, of the gripping and removing jaws and bars. Fig. 9, Sheet 4, is a sectional view through the dotted line *xx* of Fig. 8, looking to the left. Fig. 10, Sheet 4, is a view taken through the dotted line *yy* of Fig. 9, looking to the left. Fig. 11, Sheet 4, is a view taken through the dotted line *zz* of Fig. 9, looking to the left. Fig. 12, Sheet 4, is an enlarged

sectional view of the compress-box and associated parts.

The same letters of reference are used to indicate identical parts in all of the figures. 55

The machine embodying our present invention is an improvement upon that shown and described in Patent No. 418,467, issued December 31, 1889, to James B. Lawton, and, like said former machine, the frame is composed of the uprights A, two inclined bars B B, having slots *a* extending through them to form inclined guides, and the bottom bar C, Fig. 4, the whole constituting a rigid framework. Suitably journaled over the uprights A is a horizontal shaft D at right angles to the bars B and carrying one or more fly-wheels E and a central driving-pulley F. Likewise suitably journaled above the uprights A is a second shaft G, parallel to the shaft D, and having fast thereon a beveled gear H, meshing with a smaller beveled gear I, fast upon the shaft D. Upon the ends of the shaft G, outside of the bars B, are crank-disks *b*, to the wrist-pins of which are pivoted the upper ends of the two pitmen J, whose lower ends are pivoted to the projecting ends of a cross-head K, confined and guided in the lower part of the slots *a* of the bars B. Midway between the bars B the cross-head K carries upon its upper front side the lower stamping-die L. Secured between the bars B is the stationary compress-box M, with its mouth in the path of travel of the die L, and confined within the compress-box is the upper stamping and ejecting die N, fitting snugly therein and carried upon a stem *c*, projecting through the upper end of the compress-box and attached to a cross-head O, confined and guided in the upper part of the slots *a* in the bars B. The construction and operation of the parts so far described are substantially that of the patent referred to with the exceptions to be pointed out. 75 80 85 90

Attached to the upper side of the cross-head O are two ropes or chains *d*, extending up over guide-rollers *e*, journaled upon the inner sides of the bars B, and thence down, having weights *f* upon their lower ends. The office of these weights is to retract the cross-head O and die N after each cake of soap has been stamped and ejected from the compress- 95 100

box. Just above the cross-head O, and secured between the bars B, is a cross-bar P, having adjustably secured by means of bolts *g* passed through it a stop-plate *h* on the side next to the cross-head O. The upper side of the cross-head O has at its middle a bore or recess, in which is confined a helical spring *i*, Fig. 4, and into which recess is inserted a buffer *j*, bearing against the spring and having a flanged head guided on bolts *k*, Fig. 3, inserted through it into the cross-head O. When the cross-head O is retracted and reset by the weights *f*, the buffer comes in contact with the stop-plate *h*, and the blow is received and the jar prevented by the spring *i*, as will be readily understood. The die L has on its under side the sliding shelf *l*, Figs. 3 and 4, supported by the cross-head K, and constructed and operating exactly in the manner specified in the patent referred to for supporting a cake of soap placed thereon edgewise, by hand or automatically, while being carried up by the cross-head K to be finally forced into the compress-box to be stamped.

To eject the cake of soap from the compress-box after being stamped, we employ two rods Q, Figs. 1 and 3, one on each outer side of the bars B, and having their lower ends secured to the cross-head K in any suitable manner. The upper ends of the rods Q pass through bearings in the projecting ends of the cross-head O, and each has pivoted on its end above the cross-head O a gravitating dog R, whose pendent shoulder engages with the cross-head to form a lock, so that after a cake has been stamped and the cross-head K, carrying the die L, descends, the cross-head O, carrying the die N, is drawn down, the weights *f* are lifted, and the cake is ejected from the compress-box. There is an inclined nose *m* on each dog, which, just before the die N has completed its downward stroke, is caught upon a stationary incline *n*, projecting from the side bars B, and rides up on the same, thereby lifting the dogs until just at the moment the die completes its downward stroke the shoulders of the dogs are disengaged from the cross-head and the latter, with its die N, is instantly retracted and reset by the weights *f*. Upon the return upward stroke of the cross-head K the rods Q are carried up and the dogs K are drawn back with their shoulders in position to re-engage the cross-head O, as will be readily understood.

The next feature of our invention relates to the mechanism for grasping the stamped cake of soap and removing it entirely from the compress-box, to be afterward released and dropped upon any suitable carrier. This mechanism is best illustrated in Figs. 3, 6, 7, 9, 10, 11, and 12. Upon the inner side of each of the bars B, in line with the compress-box, is a sliding plate S properly guided, in this instance dovetailed in the bars B, as seen in Fig. 9. Each of these sliding plates has pivoted to it, as at *o*, two bell-crank jaws T, an upper one and a lower one for each plate.

At their lower ends the upper jaws of each plate are connected by a grasping-bar U, extending across the lower end of the compress-box just above its mouth. The lower jaws are similarly connected by a grasping-bar U', extending across the lower end of the compress-box just below its mouth. We prefer to pivot the grasping-bars in the jaws, so that their flattened sides, which come in contact with the soap, will not indent it or leave any impression.

To operate the jaws to cause the bars U to grasp the nearly-ejected cake of soap simultaneously upon its upper and lower edge, we provide for each pair of upper and lower jaws a sliding plate V, resting against the inner ends of the jaws and held in place and guided by a flanged boss *s*, inserted through an elongated slot *p*, Fig. 10, in the plate S and through an elongated slot *q*, Fig. 11, in the bar B, with the flanged portion resting against the plate S, as seen in Fig. 9. A bolt *r* unites the plate V and boss *s*, and has its projecting outer end inserted through a slot *t* in a resetting-lever *u* pivoted, as at *v*, Figs. 7 and 9, and having a spring *w* uniting its upper end to the bar B and normally holding the plate V up. Within the angles of the bell-cranks of each of the jaws T are two rollers *a' a''*, pivoted to the inner sides of the plates V and located one above the other, so as to be in contact with the two arms of the bell-crank. Extending downward from each plate V is a rod *b'*, having its lower ends inserted loosely through an aperture in the cross-head K and carrying on its lower threaded end a nut *c'*.

As seen in Fig. 10, the plates S are each provided with a pin *d'*, which projects through a slot *e''*, Fig. 11, in the bar B, and through a slot *f''* in a resetting-lever *g'*, pivoted at its upper end, as at *h'*, Figs. 1 and 7, and having a spring *i'*, uniting its lower end with the bar B. Upon the outer end of each pin *d'* is pivoted the upper end of a rod *j'*, whose lower end is loosely inserted through the cross-head K and carries on its threaded end a nut *l'*. It results from this construction and from the adjustment of the nuts *c' l'* that when the die N has reached the position shown in Fig. 12 in ejecting the cake of soap A' from the compress-box the lower cross-head K in its descent engages the nuts *c'* and draws down the rods *b'*, thereby causing the plates V to be drawn down simultaneously and causing the rollers *a''* to press upon all of the jaws in such manner as to draw together the bars U and cause them to grip the cake of soap A', as shown by the solid lines in Fig. 12. The nuts *l'* are so adjusted that the moment the cake is so gripped they are caught by the cross-head K in its descent, and the rods *j'* are simultaneously drawn down, thereby drawing down the plates S, and with them the gripping-bars, to remove the cake of soap entirely out of the mouth of the compress-box. It remains so held by the gripping-bars until the cross-head K again ascends and releases the nuts *c' l'*,

whereupon the springs $w\ i'$, which had been put under tension by the downward travel of the plates $S\ V$, being released, retract and reset said plates, and by the retraction of the plates V cause the rollers a' to throw open the jaws and release the cake of soap. Where oval cakes of soap are to be stamped, the gripping-bars U are curved to conform to the shape of the cake, as will be readily understood.

The remaining feature of our invention relates to the mechanism for automatically feeding the cakes of soap upon the shelf l in front of the die L , and it is illustrated in Figs. 1, 3, and 4. Between two uprights B' we secure an inclined trough C' , whose lower end opens into the upper end of an inclined feed-box D' , containing a reciprocating plunger E' , connected by a pitman F' with a crank G' , journaled in the uprights B' , and connected by an arm H' , fast upon one end thereof, to a second slotted arm I' , as at n' , pivoted at its upper end, as at m' , Fig. 1, and connected at its lower end to a rod J' , extending down from the cross-head K . The adjustment of the parts is such that the plunger E' has a reciprocating play in the box D' very slightly greater than the width of a cake of soap. The trough C' has constantly in it a column of cakes of soap, and the extreme downward play of the cross-head K brings the front face of the die L directly under the edge of the box D' , with the shelf l projected. This downward movement of the cross-head K causes the plunger E' to move in an opposite and upward direction, thereby forcing out the bottom cake of soap and taking its place to keep the other cakes of the column up. The bottom cake, when forced up, tips over and falls in proper position upon the shelf l in front of the die L . When the cross-head K travels up, the plunger E' is retracted from under the column of cakes, permitting them to fall, with the bottom cake in the box D' in front of the plunger ready to be projected upon the return-stroke of the cross-head, as will be readily understood.

In Fig. 3 the box D' is represented as provided with adjustable side walls o' , held and moved in and out by set-screws p' , bearing in the outer stationary walls of the box to accommodate cakes of soap of varying lengths.

In Fig. 5 the forward end of the feed-box D' is shown as curved downward at its upper end, and the plunger is composed of hinged sections, so that it can follow the curvature.

The pitmen are represented as divided and provided with adjustable couplings q' , of any suitable construction, by which they can be lengthened or shortened to adjust the cross-head K and its die L .

The modification represented in Fig. 2 consists in forming a shallow groove r' around the interior of the compress-box near its mouth to prevent the accidental withdrawal of the stamped cake by the drawing out of the die L , to which the cake might adhere.

Having thus fully described our invention, we claim—

1. The combination, with the compress-box M and its contained die N , of the cross-head carrying the die N , the stop-plate h , buffer j between said stop-plate and cross-head, and retracting and resetting weights for said cross-head and die, substantially as described.

2. The combination of the compress-box M , die N , stem c , recessed cross-head O , spring i , buffer j in contact with said spring, adjustable stop-plate h , rollers e , ropes d , and weights f , substantially in the manner and for the purpose specified.

3. The combination of the reciprocating cross-head K , carrying the die L , the compress-box M , its contained die N , carried by the cross-head O , the rods Q , carried by the cross-head K and provided with pivoted dogs R to engage the cross-head O on the down-stroke of the cross-head K , releasing-shoulders n for the dogs, and retracting and resetting weights f for the cross-head O and die N , substantially in the manner and for the purpose specified.

4. The combination, with the compress-box and its contained die, of the soap-carrying die carried by a reciprocating cross-head, gripping-bars in front of the mouth of said compress-box, swinging and sliding jaws carrying said gripping-bars, mechanism connecting said cross-head and gripping-jaws to cause the bars to grasp the partially-ejected soap cake and remove it from the compress-box, and mechanism for resetting said jaws and bars and releasing the soap cake, substantially as described.

5. The combination, with the compress-box and its contained die, of the jaws T , carrying the bars U , the sliding plate S , to which the jaws T are pivoted, the sliding plate V , carrying rollers $a' a''$ for swinging the jaws, the rods b' for the plates V , the rods j' for the plates S , the reciprocating cross-head K for actuating said rods in one direction, and the spring-actuated resetting-levers $u g'$ for actuating said plates and rods in the opposite direction, substantially in the manner and for the purpose specified.

6. The combination, with the reciprocating cross-head and its die L and shelf l , of the feed-trough C' , feed-box D' , plunger E' , and connecting mechanism between said plunger and cross-head for reciprocating the former, substantially as described.

7. The combination of the reciprocating cross-head K , with its die L and shelf l , the feed-trough C' , feed-box D' , plunger E' , pitman F' , crank G' , arms $H' I'$, and rod J' , substantially in the manner and for the purpose specified.

JAMES B. LAWTON.
JOHN A. MERGENTHAL.

Witnesses:

J. THOMSON CROSS,
G. S. WENTWORTH.