



HU000027978T2

(19) **HU**(11) Lajstromszám: **E 027 978**(13) **T2****MAGYARORSZÁG**
Szellemi Tulajdon Nemzeti Hivatala**EURÓPAI SZABADALOM**
SZÖVEGÉNEK FORDÍTÁSA(21) Magyar ügyszám: **E 07 725039**
(22) A bejelentés napja: **2007. 05. 09.**(51) Int. Cl.: **B65G 15/14** (2006.01)
B65G 39/06 (2006.01)(96) Az európai bejelentés bejelentési száma:
EP 20070725039(86) A nemzetközi (PCT) bejelentési szám:
PCT/EP 07/004117(97) Az európai bejelentés közzétételi adatai:
EP 2016010 A1 **2007. 11. 22.**(87) A nemzetközi közzétételi szám:
WO 07131690(97) Az európai szabadalom megadásának meghirdetési adatai:
EP 2016010 B1 **2016. 02. 24.**(30) Elsőbbségi adatok:
202006007637 U **2006. 05. 11.** **DE**(73) Jogosult(ak):
VHV Anlagenbau GmbH, 48477 Hörstel (DE)(72) Feltaláló(k):
VERLAGE, Bernhard, 48477 Riesenbeck (DE)(74) Képviselő:
SBGK Szabadalmi Ügyvivői Iroda, Budapest(54) **Felhordó szállítószalag laza ömlesztett áru számára**

Az európai szabadalom ellen, megadásának az Európai Szabadalmi Közlönyben való meghirdetésétől számított kilenc hónapon belül, felszólalást lehet benyújtani az Európai Szabadalmi Hivatalnál. (Európai Szabadalmi Egyezmény 99. cikk(1))

A fordítást a szabadalmas az 1995. évi XXXIII. törvény 84/H. §-a szerint nyújtotta be. A fordítás tartalmi helyességét a Szellemi Tulajdon Nemzeti Hivatala nem vizsgálta.

EP 07 725 039

Steep angle belt conveyor for loose bulk material

The invention relates to a steep angle belt conveyor for loose bulk material according to the preamble of claim 1.

In known steep angle belt conveyors (DE 34 29 940 C2, DE 297 17 996.9) at least one first conveyor belt that receives the bulk material to be conveyed, and a second conveyor belt that is assigned thereto as a cover band, cooperate in a conveyor system. Different inclinations can be overcome in this steep angle belt conveyor after the belts have been brought together in the conveying direction, undesired slippage of the bulk material between the belts being prevented by means of pressing. In the conveying phase, when the belts are brought together, the bulk material located on the first conveyor belt is fed into a curved transition zone where it is covered by the cover band which already extends in parallel (see also US 4,936,441; DE 26 14 109 A1; EP 0 626 326 A; EP 0 498 671 A).

The two opposing sides of the belts are pressed together in this transition zone by means of upper and lower pressing elements, so that the bulk material that is conveyed in a substantially centred manner is retained in a receiving chamber that is sealed at the edges, is prevented from escaping laterally, and can be conveyed out upon reaching a higher delivery location. In known steep angle belt conveyors, the service life of the conveyor belts is negatively affected by a plurality of pressing elements and the associated belt stress due to a plurality of deformation zones. In US 3,762,534 A, a single-piece pulley having a concave shaped central part is provided in the transition zone so that a trough-shaped portion of the conveying side can rest thereon. Similar pulley structures are disclosed in GB 2 008 527 A, US 2001/052450 and FR 2 619 090 A1.

The problem addressed by the invention is that of providing a steep angle belt conveyor for loose bulk material, the components of which, while having little structural complexity, ensure that bulk materials of variable consistency are completely covered in the region of the transition zone, it being possible at the same time to increase the service time of the belts due to low frictional and deformational stresses.

This problem is solved by the invention by a steep angle belt conveyor having the features of claim 1. Reference is made to claims 2 to 12 with respect to significant further embodiments.

The steep angle belt conveyor is provided with just one roll body in the region of the transition zone, which body is arranged as the central element of a bending station that can be integrated into a conveying system, with the result that a compact functional assembly is achieved using advantageously few components. Said roll body functions in the bending station in the manner of a closing pulley when the bulk material is received, by means of which pulley in particular the cover band, which can be deformed in a jaw-like manner in cross section, is pressed against the edge of the conveyor belt that is fed therebelow.

In this design of the bending station, the loaded side of the conveyor belt and the side of the cover band that is fed thereabove are laid on top of one another, tensioned and simultaneously deflected directly on the roll body. In this connection phase, the bulk material positioned in the central region of the belts is prevented from escaping laterally without the need for any additional pressing elements, and the conveying side, which is multi-layered after this phase, can assume essentially any inclination and/or deflection positions during its further movement that is inclined in the conveying direction.

Bending stations of this kind that comprise the roll body according to the invention can be of variable client-specific designs, meaning that conveying systems having C-shaped and/or S-shaped belt guides are possible. It is also conceivable to use this one-roller system for vertical bends, in which steep angle conveying having a deflection of greater than 90° is provided.

The roll body is formed having a plurality of support zones along the periphery in the direction of the longitudinal mid-plane thereof, which support zones allow the conveying side to be carried in a manner that is optimal in terms of stress, a central receiving zone being provided for the region of the bulk material strand by means of support cylinders that are adjustable according to the invention and are arranged between two support regions that produce the edge-sealed pressed connection of the two belts. Said receiving zone can be variably adapted to the bulk material, such that a shaping of the deflected cover band that is produced by the strand-like pressed bulk material and that forms a radially projecting bulge can be moved radially in this receiving zone.

Proceeding from the movement phase, when the two sides are brought together and laid on top of one another, the central portion of the cover band that is radially shaped in the process is also transported over a curved region of the roll periphery, and the central bulge part is pressed into the receiving zone between the two support cylinders as a result of tensioning the belt. In the process, a counter member that is provided in the receiving zone of this assembly in the form of spring elements produces counter-pressing on the bulge-like portion, such that speed differences that occur when the belts are deflected and that are caused by the radial spacing between the conveyor belt and the cover band, can be compensated by the counter member. Disadvantageous wear stresses, in particular as a result of rubbing surface regions or flexing movements of the belts, are thus prevented.

The roll body that has a larger diameter, for example in comparison with known pressure rollers (DE 297 17 996.9), makes it possible to efficiently replace pressing elements, in particular in the form of a plurality of rolling chairs or the like, that have previously been provided in the region of the transition zone that brings the belts together, and the comparatively low pressing and flexing stresses achieve an advantageous increase in the service life of the belts.

Further details and advantageous embodiments will emerge from the following description and the drawings, which illustrate in more detail an embodiment of the subject matter of the invention. In the drawings.

- Fig. 1 is a side view of a bending station of a steep angle belt conveyor, which bending station forms a transition zone for two belts, having a roll body that functions directly as a deflection and pressing drum,
- Fig. 2 is a plan view of the steep angle belt conveyor in the region of the bending station according to Fig. 1,
- Fig. 3 is a front view of the steep angle belt conveyor according to Fig. 1,
- Fig. 4 is a perspective view of the steep angle belt conveyor in the region of the bending station according to Fig. 1,

- Fig. 5 is a perspective detail view of the roll body of the bending station according to Fig. 1,
- Fig. 6 is a sectional view of the roll body according to Fig. 5,
- Fig. 7 is a partial cross section of the roll body that is similar to Fig. 5 but having a second embodiment of the mounting of the spring elements,
- Fig. 8 shows the second embodiment of the roller body, in a similar manner to Fig. 6, and
- Fig. 9 to Fig. 11 are detail views in each case of significant details of the mounting according to Fig. 7 and 8.

Fig. 1 shows a steep angle belt conveyor that is generally denoted by A, by means of which, in a conveyor system (not shown in further detail), loose bulk material 1 in a feed region 2 is fed to a first rotationally driven conveyor belt 3 (arrow direction B, B'). The bulk material 1 which is fed in a substantially centred manner onto said first conveyor belt 3 is then moved in the conveying direction B to a transition zone Z where it is covered by a second conveyor belt 4 fed through as a cover band. The two belts 3, 4 are pressed against one another transversely to the running plane E in a steep portion of a conveying path F downstream of this curved transition zone Z, such that the grasped bulk material 1 can be transported between the two belts 3, 4.

According to the invention, a bending station 5 is provided that triggers the pressing of the belts that is known per se, in the transition zone Z of which bending station a roll body 6 is provided that grasps both the loaded side of the conveyor belt 3 and the side of the cover band 4 which is fed above said conveyor belt. The two belts 3, 4 can be laid over one another by means of this one roll body 6 in order that at least the respective side edge regions 7, 8 (Fig. 2) can be pressed on one another in a closed position and that the bulk material 1 located in the central region of the belts can be covered such that the conveying side T formed in this conveying phase can be moved further in a multi-layered manner in the direction of the conveying path F (arrow C). This construction having just the one roll body 6 for initiating steep angle conveying provides that the two sides of the conveyor belt 3 and cover band 4 that are fed through can be simultaneously tensioned and deflected.

Of course, the bending station 4 comprising the roll body 6 can also be arranged in the region of a transition zone located above the steep portion of the conveying path F and the cover band 4 is lifted off the conveyor belt 3 here. This conveying situation, in which the components cooperate in the reverse operational position, will not be described in greater detail.

The two belts 3, 4 are adapted to the tensioning and deflection principle by means of the roll body 6 such that at least one of the two sides that are fed through can form a receiving chamber 9 (Fig. 2) for the bulk material 1 by means of a radial shaping, the formation of the receiving chamber 9 by the cover band 4 being shown in this case. In this case it is also conceivable for the conveyor belt 3 that is on the outside in the region of the conveying side T to be removed to the outside in regions by means of a corresponding additional assembly (not shown) and for a receiving chamber to thus be formed by means of the opposing radial movement of a portion of the conveyor belt 3.

In the embodiment of the steep angle belt conveyor A shown (Fig. 1 to Fig. 4), it is clear that the roll body 6 has a receiving zone 10 on either side of the mid-plane M in the central region thereof in the longitudinal direction, into which receiving zone a portion of the cover band 4 that is formed by the grasped bulk material 1 in the transition zone Z and projects radially inwards can be pressed (Fig. 2, sectional view).

It is clear from this expedient embodiment of the bending station 5 that the two sides of the belts 3 and 4 that are brought together in a connection region P on the periphery of the roll body 6 pass through a circular arc-shaped carrying region 11 on the roll body 6 in the conveying direction C, and in the process the inner side of the cover band 4 and the radial shaping thereof are moved into the receiving zone 10 of the roll body 6 and thus the conveying side T that is closed at the edges can be moved further in an optionally inclined (angle N, N'; Fig. 1) conveying direction C.

The schematic view according to Fig. 1 shows that the roll body 6 is contained in an arc-shaped profile that forms a quarter circle extending from region P to region P' of the conveying side T in such a way that said carrying region 11 produces a 90° deflection (angle N) of the conveying side T. An angle N' indicates a further conceivable direction of the substantially arbitrary deflections in the region of the bending station 5. It is also conceivable

to provide a conveying direction that goes beyond the 90° deflection in the manner of what is known as a vertical bend (not shown), which makes it clear that the bending station 5 can also be adapted to virtually any conveying systems having S-shaped and/or C-shaped deflection.

It can be seen from the overview of Fig. 2 to 4 that the roll body 6 comprises, in the direction of the longitudinal shaft 12 thereof, two support cylinders 13, 14 that engage below the side regions 7, 8 of the cover band 4 and the conveying side T respectively, and a free space that defines the receiving zone 10 is provided between said two support cylinders 13, 14 in the direction of the longitudinal shaft 12, into which free space the above-described radial shaping or the receiving chamber 9 of the conveying side T can be pressed. The length A' of said receiving zone 10 that corresponds to the spacing of the support cylinders 13, 14 is variable in that the two support cylinders 13 and 14 that are of substantially the same length U, U' can be moved and/or adjusted in the direction of the longitudinal shaft 12 (Fig. 2; arrow D, D').

The partial sectional view according to Fig. 2 also shows that the roll body 6 is provided, in the region of the receiving zone 10, with at least one counter member 15 which covers at least portions of said receiving zone and which produces a radial supporting force G on the conveying side T in the region of the radial shaping or of the receiving chamber 9. In a conceivable embodiment, the counter member 15' (Fig. 2, detail, left-hand side) can be formed as tubular cladding 16 that consists of an elastically deformable material and completely covers the receiving zone 10 in the longitudinal and peripheral direction, which cladding is not part of the invention.

In a first pressing phase (Fig. 1, side T') occurring on the roll body 6, the cover band 4 having a width W (Fig. 2) is already resting in the region of the receiving zone 10 after being guided on an upper pulley 33 in an arc-shaped feed side T', and is also radially loaded by the belt tension of the system. The cover band 4 is pressed against the counter member 15 in a deforming region (dotted line W', Fig. 2) in the side T', such that a jaw-like receiving profile is already formed (Fig. 3) in front of the connection region P and the process for receiving the bulk material 1 can be performed in an optimal manner.

Fig. 5 and 6 show a further embodiment of the roll body 6, said roll body comprising, as a counter member 15'', a plurality of spring elements 17 that extend between the two support

cylinders 13 and 14 in the region of the receiving zone 10. In an expedient embodiment, said spring elements 17 are formed as helical springs 18 which are held in the region of the support cylinders 13, 14 by means of respective support rings 19, 20 which are connected to said support cylinders and extend radially to the longitudinal shaft 12. Since the roll body 6 is constructed in a substantially mirror-imaged manner with respect to the longitudinal mid-plane M, the corresponding arrangement of the components is clear from the drawings without each of said components needing to be described in detail.

In this case, the helical springs 18 are held by respective adjusting screws 21 passing through the support ring 19, 20. In this case, the connecting hooks 22 of the helical springs 18 engage in respective grommets 23 of the adjusting screws 21 in such a way that the helical springs 18 are also pivotable (arrow Q) in the biased installation position. When the cover band 4 that forms the receiving chamber 9 is laid on as described above, the springs 18 can be both moved in the radial direction (arrow R) into the above-described receiving zone 10 and pivoted about the longitudinal centre axis L thereof according to the movement arrow Q. In this pressing phase of the cover band 4, the counterforce G that acts according to the spring characteristic is produced simultaneously, and as a result disadvantageously great speed differences between the two belts 3 and 4 that have different diameters on the roll body are prevented. The smaller speed difference between the belts on the roll body 6 can be detected when comparing the diameter of the roll body 6 with known deflection pulleys having a significantly smaller diameter, with the result that said belts have substantially lower frictional stresses.

The helical springs 18 are fixed by means of the adjusting screws 21 in such a way that the axial bias of each of the helical screws 18 can be individually measured by means of the respective adjustments of tensioning nuts 24 (arrow K). This counterpressure system G can thus be adjusted to the volume and the consistency of the bulk material 1 and to the size, thus formed, of the receiving chamber 9.

Said helical screws 18 that are held in the region of the support rings 19, 20 cooperate with a support sleeve 25 that surrounds the longitudinal shaft 12 in that the support ring 19 that is fixed to the outside of the support cylinder 13, 14 is connected on the inside to the support sleeve 25, for example by means of a welded connection at 26. The support sleeve 25 is provided, at the outside end thereof, with a mounting that is denoted as a whole by 27. Said

mounting 27 permits complete tensioned adjustment of all of the helical springs 18 as an assembly.

For this purpose, the mounting 27 comprises a retaining plate 28 that rests on a retaining lug 29 of the longitudinal shaft 12 and cooperates, by means of adjusting screws 30, with an outer adjusting disc 31 that is fixed to both the support cylinder 13, 14 and the support sleeve 25. The tension of the helical springs 18 is released in the direction of the longitudinal mid-plane M by means of corresponding axial loading (arrow H') of the support sleeve 25, for example by means of one of the adjusting screws 30 or 32. A reverse tensioning movement (arrow H) increases the bias of the helical springs 18.

The steep angle belt conveyor A described above is designed in the region of the bending station 5 in such a way that efficient deflection of the conveyor belts 3, 4 from the horizontal direction into the vertical direction is possible, in the manner of a twin-belt vertical conveyor, and this deflection can also occur from the vertical into the horizontal (not shown). The bulk material 1 is transported upwards between the two conveyor belts 3, 4 in a frictional manner, the side edge regions 7, 8 functioning as respective sealing surfaces. The roll body 6 that functions as a bending and deflection drum makes it possible to gently deflect the bulk material 1, the undesired movement thereof into the edge regions 7, 8 being reliably prevented, even in the ascending region F.

In a prototype of the roll body 6, the two support cylinders 13, 14 arranged in the manner of axially movable drum casings are formed having a diameter of 800 mm. The spring elements 17, which function as radial compensators and extend so as to have a uniform diameter in the support zone 10 in the initial state, are pressed radially inwards to a diameter of approximately 600 mm in the region of the conveying side T that is loaded with bulk material 1. In this case, the two support cylinders 13 and 14 are arranged, in the conveying phase, as assemblies that are fixed in the direction of the longitudinal shaft 12, and a deflection that is gentle on the belt is already achieved merely by using the resilience in the region of the spring elements 15, 15', 15".

It is also conceivable to arrange the two support cylinders 13, 14 on the longitudinal shaft 12 so as to be permanently axially movable (arrow D, D', Fig. 22), and to connect said cylinders for example by means of the elastically deformable tubular cladding 16, which is not to be

considered part of the invention. Changing volumes of the bulk material 1 or solids contained therein can thus be compensated by means of variably moving the cylinder 13 and/or 14.

In each case, the bulk material 1 is moved only once in relation to the two belt surfaces in the deflection phase (conveying side T), damage to the conveyor belts 3, 4 due to sharp-edged or bulky pieces of material being prevented by the above-described resilient compensation. The bulk material 1 or ingredients contained therein can be diverted towards the receiving zone 10 that functions as a free space or against the resilient counter member 15, 15', 15'', and at the same time said counter member supports the conveyor belt provided as the cover band 4 in such a way that the operation characteristics thereof are not adversely affected.

It is also conceivable, in this connection, to limit the receiving zone 10 comprising the free space by means of a rigid counter member (not shown) that is not part of the invention, an additional separate bearing in the region of the longitudinal shaft 12 being required for this, however. Sharp-edged regions pointing towards the support zone 10 can occur in the transition region between the two support cylinders 13 and 14, which sharp-edged regions have notch effects that disadvantageously strain the conveyor belts.

In the embodiments of the roll body 6 shown, respective guide profiles 13' and 14' that are inclined towards the longitudinal mid-plane M are provided on the two support cylinders 13, 14, so that even and edge-free guiding of the bulge zone of the cover band 4 is achieved in this pressing region.

The design comprising the resilient compensator 15, 15', 15'' that is achieved in an expedient embodiment produces compensation, in the region of the receiving zone 10, between the two diameter-dependent different peripheral speeds of the belts 3 and 4, since the resilient counter member 15, 15', 15'' can compensate a radial relative movement of the cover band 4 with respect to the first conveyor belt 3 that revolves having an unchanged profile. After the conveying side T has run off the peripheral surface of the roll body 6 (in the region P', Fig. 1), the counter members 15, 15', 15'' automatically return to their original initial position and engage below the side T' when the roll body 6 is rotating.

Fig. 7 to 11 show further variants of the roll body 6 or the components thereof, a second embodiment of mountings of the spring elements 17' provided as counter members 15''

being provided. Instead of having the support rings 19, 20 shown in Fig. 5 and 6 as the mounting, the spring elements 17' that are distributed over the periphery of the receiving zone 10 are now connected to a two-part support sleeve 25' (which is in turn held on the longitudinal shaft 12) by means of the components shown in Fig. 9 to 11.

In this case, the spring elements 17' that are held in a mirror-imaged manner with respect to the mid-plane M are each connected at the ends thereof to retaining plates 36 which comprise at least one carrying hook 35 (Fig. 10) and are distributed over the cylindrical interior of the support cylinders 13, 14 in the manner of spokes. It is also conceivable to provide the profile of the retaining plate 36 with a hook-like extension so that an integral "spoke" structure is achieved (not shown) and the spring elements 17' engage directly therewith.

In the embodiment shown, the retaining plates 36 are provided with an additional intermediate part 37 that is U-shaped in cross section, one of the carrying hooks 35 being held on each of the free limbs 38, 39 thereof. A base limb 40 of the U-shaped intermediate part 37 is connected to the retaining plate 36 in particular by means of a welded connection at 40' (Fig. 7). In Fig. 9, the intermediate part 37 is shown as a plate-like initial part, the limbs 38, 39 of which are bent in the region of bend lines 38', 39' into the U-shape provided in the installation position (Fig. 7).

In this three-part unit 35, 36, 37, each carrying hook 35 comprises a receiving profile 42 (Fig. 10) which receives the counter member 41, formed as a loop or similar, of the spring element 17'. This profile optimises the connection structure such that, in the operating position of the roll body 6 (Fig. 8), a movement at the end of the spring elements 17', when the pressing or tensile force (arrow R, Q', Q'') is applied, can be introduced into the support structure of the roll body 6 in a low-friction manner.

The enlarged detail view of the carrying hook 35 according to Fig. 10 shows that a support path S, which is suitable in particular for a rolling movement (arrow S') of the counter member (41), is predetermined by means of the receiving profile 42 and, as a result, rapid wear in this highly stressed region, for example due to sliding friction at specific points, can be prevented. In an expedient embodiment, the carrying hook 35 is in addition manufactured from a particularly wear-resistant material. Screw connections 43 are advantageously provided in the region of each of the U-limbs 38, 39 of the intermediate part 37 for mounting

the carrying hooks 35, making it possible to exchange the carrying hooks 35 or the spring elements 17' in an uncomplicated manner.

This simple assembly and disassembly in the region of the spring elements 17' is further promoted in that respective free spaces 44 are formed in the longitudinal direction of the roll body 6 on account of the "spoke" structure, and the components, which are in particular releasably held, are easily accessible as a result. In an expedient embodiment, the retaining plate 36 is welded to the two support sleeves 25' in the region of profiled recesses 45, 46 (Fig. 11) in each case, and the welded connection 40' to the intermediate part 37 comprising resting profiles 49, 49' is provided in the region of a shaped recess 47. The retaining plates 36 are also fixed by means of welded connections 48 with respect to the support cylinders 13 and 14 (Fig. 7).

The "spoke" structure described above can be adapted to different diameters and lengths of the roll body 6 and variable spring elements 17' respectively by appropriately dimensioning the components 35, 36, 37. It is likewise conceivable to provide a radially and/or axially adjustable support (not shown) for the spring elements 17' in the region of the retaining plates 36 or the carrying hook 35 that is held on the intermediate part 37.

FELHORDÓ SZÁLLÍTÓSZALAG LAZA ÖMLESZTETT ÁRU SZÁMÁRA

SZABADALMI IGÉNYPONTOK

1. Felhordó szállítószalag laza ömlesztett áru (1) számára, amely szállítószalag rendelkezik egy első szállítóhevederrel (3) és egy ehhez fedőszalagként hozzárendelt második szállítóhevederrel (4), továbbá az első szállítószalagra (3) lényegében középpontosan táplált ömlesztett árut (1) egy, a két heveder (3, 4) között lévő, a szállítási irányban (B) ívelt átmeneti zóna (Z) területén lehet fogadni, és az ömlesztett árunak (1) a szállítási út (F) egy ezután elhelyezkedő meredek részzszakaszán való szállításához a két heveder (3, 4) a haladási síkra (E) keresztben egymáshoz van szorítva, az átmeneti zónában (Z) egy mind a szállítóheveder (3) megrakott ágára, mind a fedőszalag (4) efölött táplált ágára kiterjedő hengertest (6) áll rendelkezésre, ezenkívül a hevederek (3, 4) két táplált ága közül legalább az egyik egy sugárirányban kialakított fogadóteret (9) képez az ömlesztett áru (1) számára, a hengertestnek (6) van egy fogadózónája (10), amelybe a fedőszalagnak (4) a felvett ömlesztett áru (1) miatt sugárirányban befelé kiálló részzszakasza áthelyezhető, a hengertestnek (6) a hossz tengelye (12) irányában van két, a szállítóág (T) két szélrészének az alátámasztására szolgáló tartóhengere (13, 14), ezek határozzák meg a szállítóág (T) sugárirányú kialakítását befogadó fogadózónát (10), és a hengertest (6) a fogadózóna (10) területén el van látva legalább egy ellendarabbal (15), amely legalább részben befedi a fogadózónát, és legalább a többrétegű szállítóágra (T) sugárirányú támasztóerőt (G) gyakorol, azzal jellemezve, hogy a hengertestnek (6) ellendarabként (15") a fogadózóna (10) területén több, a két tartóhenger (13, 14) között kiterjedő rugós eleme (17, 17') van.

2. Az 1. igénypont szerinti felhordó szállítószalag, azzal jellemezve, hogy a hengertestnek (6) egy, a hossz tengely (12) irányában áthelyezhető tartóhengerekkel (13, 14) állítható fogadózónája (10) (D, D' nyíl) van.

3. Az 1. vagy a 2. igénypont szerinti felhordó szállítószalag, azzal jellemezve, hogy a csavarrugókként (18) kialakított rugós elemek (17) a tartóhengerek (13, 14) területén egy-egy, a hengerekkel összekötött és támasztótárcsaként (19, 20) kialakított tartóeszközbe kapcsolódnak.

4. A 3. igénypont szerinti felhordó szállítószalag, azzal jellemezve, hogy a csavarrugók (18), amelyeket a támasztótárcsán (19, 20) átnyúló állítócsavarok (21) tartanak, a fedőszalag (4) felfekvésekor elforduló mozgást (Q nyíl) tudnak végezni.

5. A 3. vagy a 4. igénypont szerinti felhordó szállítószalag, azzal jellemezve, hogy

a csavarrugók (18) hosszirányban állítócsavarokkal (21, 30, 32) megfeszíthetők (H, H' nyíl).

6. A 3-5. igénypontok egyike szerinti felhordó szállítószalag, azzal jellemezve, hogy a csavarrugók (18) támasztótárcsája (19, 20) együttműködik egy, a hossz tengelyt (12) magában foglaló támasztóhüvellyel (25), amelynek van egy, a csavarrugók (18) feszítését (H, H' nyíl) szolgáló tartója (27).

7. A 6. igénypont szerinti felhordó szállítószalag, azzal jellemezve, hogy a tartó (27) el van látva egy tartólemezzel (28), amelynek több, sugárirányban eltolható állítócsavarja (30) van, és amely felfekszik a hossz tengely (12) egy tartóállán (29), továbbá együttműködik egy, az eltolható támasztóhüvellyel (25) tartott állító tárcsával (31).

8. A 3-7. igénypontok egyike szerinti felhordó szállítószalag, azzal jellemezve, hogy az ellendarabokként (15") rendelkezésre álló rugós elemek (17') a végükön össze vannak kötve a tartóhengerek (13, 14) belső tere felett küllők módjára elosztott tartólemezekkel (36), amelyeknek van legalább egy tartókampója (35).

9. A 8. igénypont szerinti felhordó szállítószalag, azzal jellemezve, hogy két-két tartókampó (35) egy keresztmetszetben U alakú közbenső részen (37) át össze vannak kötve egy-egy tartólemezzel (36).

10. A 8. vagy a 9. igénypont szerinti felhordó szállítószalag, azzal jellemezve, hogy a tartókampónak (35) egy, a rugós elem (17') szem vagy hasonló formájában kialakított ellendarabját (41) befogadó befogadó-körvonala (42) van oly módon, hogy a hengertest (6) munkahelyzetében a rugós elemek (17') mozgása a végükön (Q', Q" nyíl) kis súrlódással vehető fel.

11. A 10. igénypont szerinti felhordó szállítószalag, azzal jellemezve, hogy a befogadó-körvonallal (42) egy, az ellendarab (41) gördülő mozgása számára alkalmas támasztófelület (5) biztosítható.

12. A 3-11. igénypontok egyike szerinti felhordó szállítószalag, azzal jellemezve, hogy a tartólemezek (36) területén a rugós elemeknek (17') egy tengelyirányban és/vagy sugárirányban állítható alátámasztása van kialakítva.

(A meghatalmazott)

Mészárosné Dónusz Katalin
Szakmai Igazgató
SEKK Szakmai Igazgató Irodája
H-1052 Budapest, Szabadság út 113.
Tel: +36 1 460 1111
E-mail: ddonusz@sekk.hu

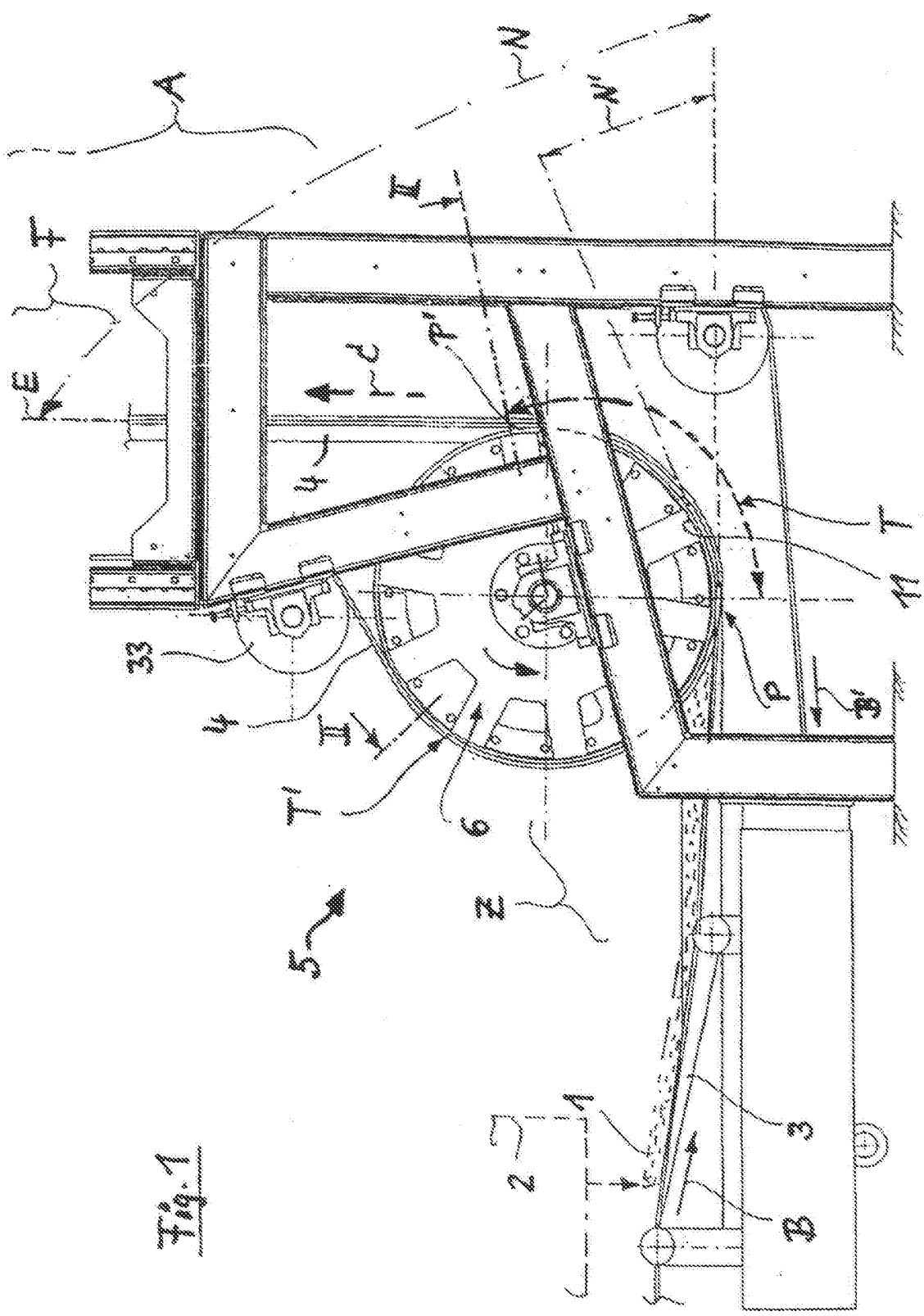

Fig. 1

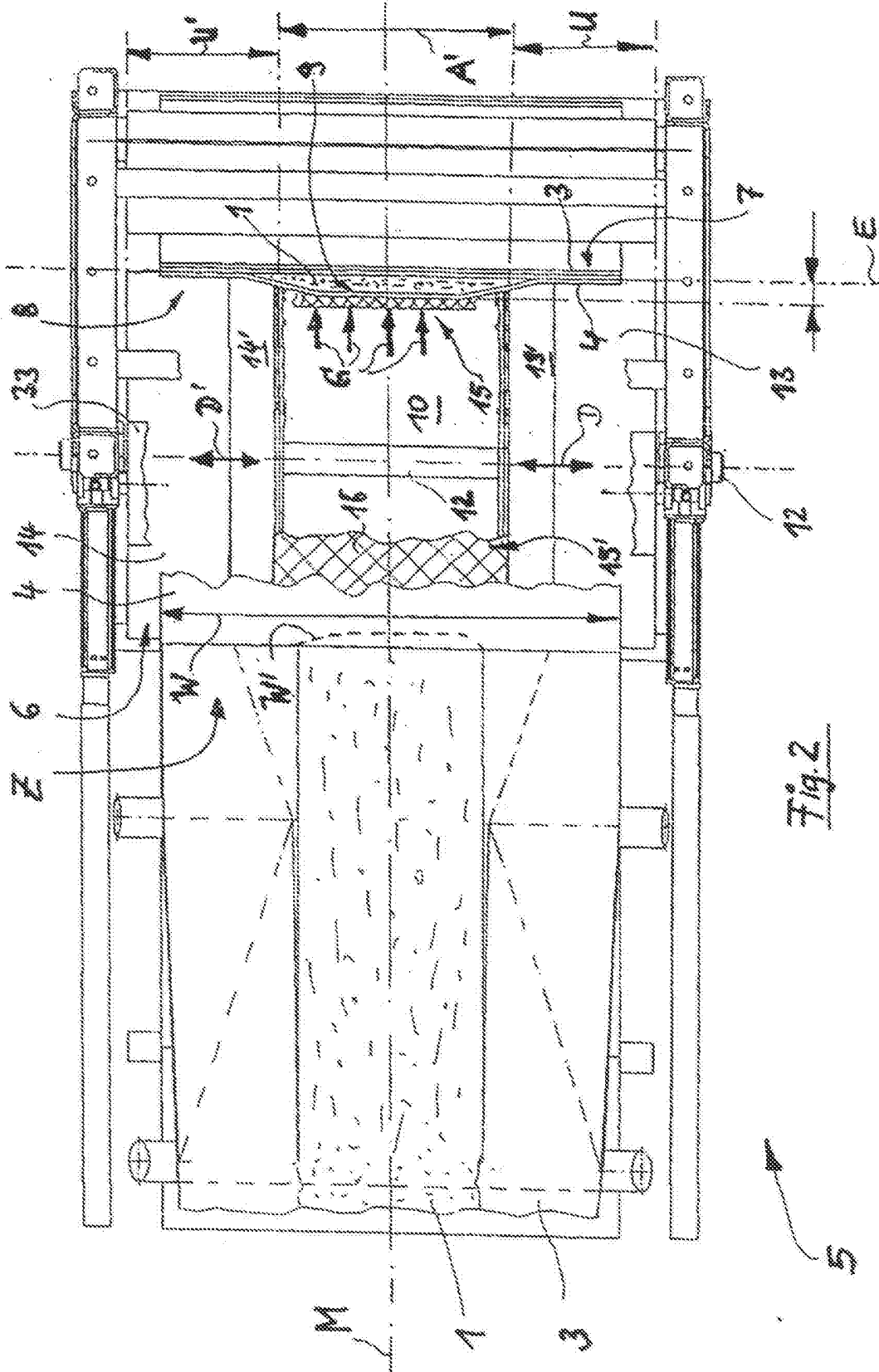

Fig. 2

5

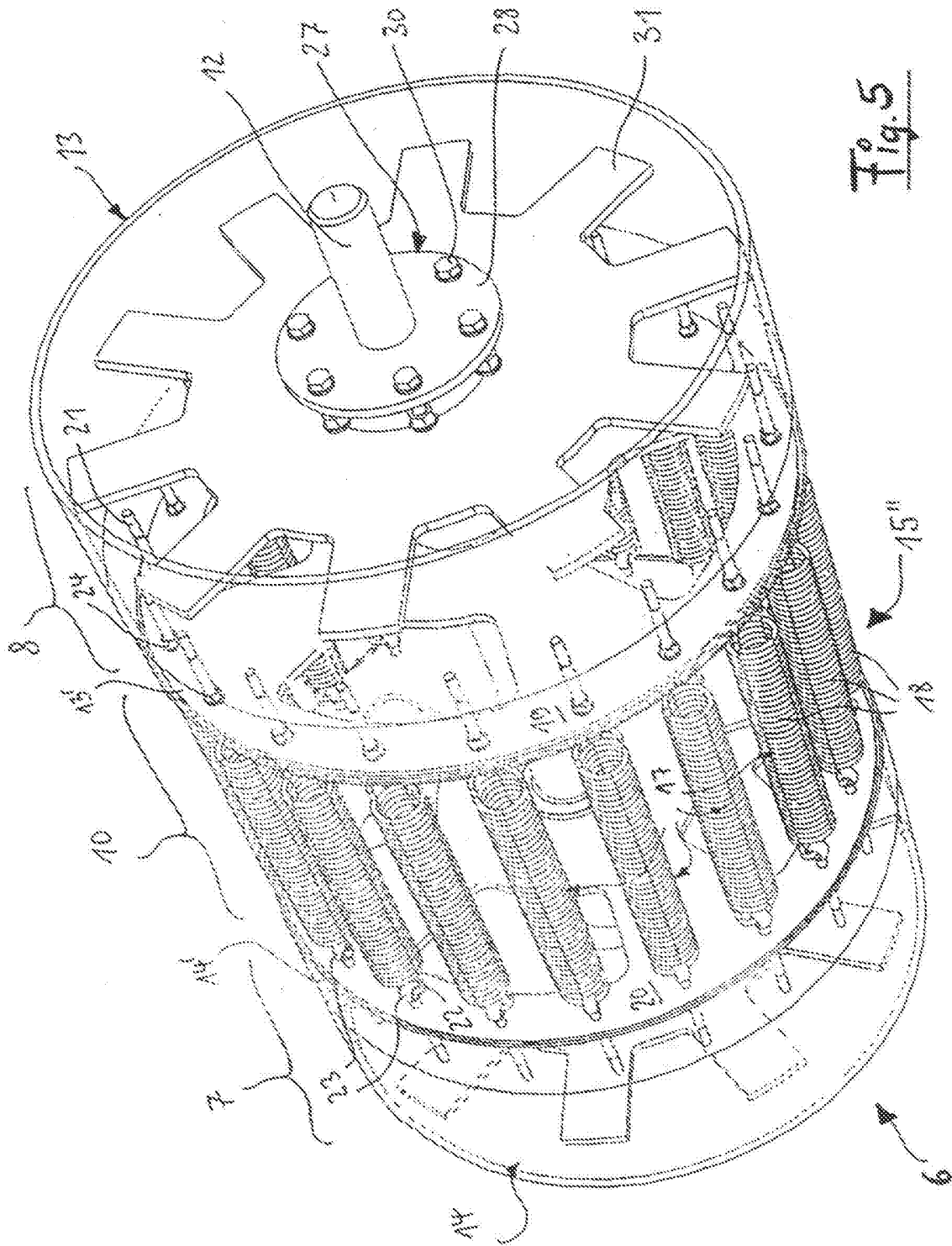

Fig. 5

6/9

EP 2 016 010 B1

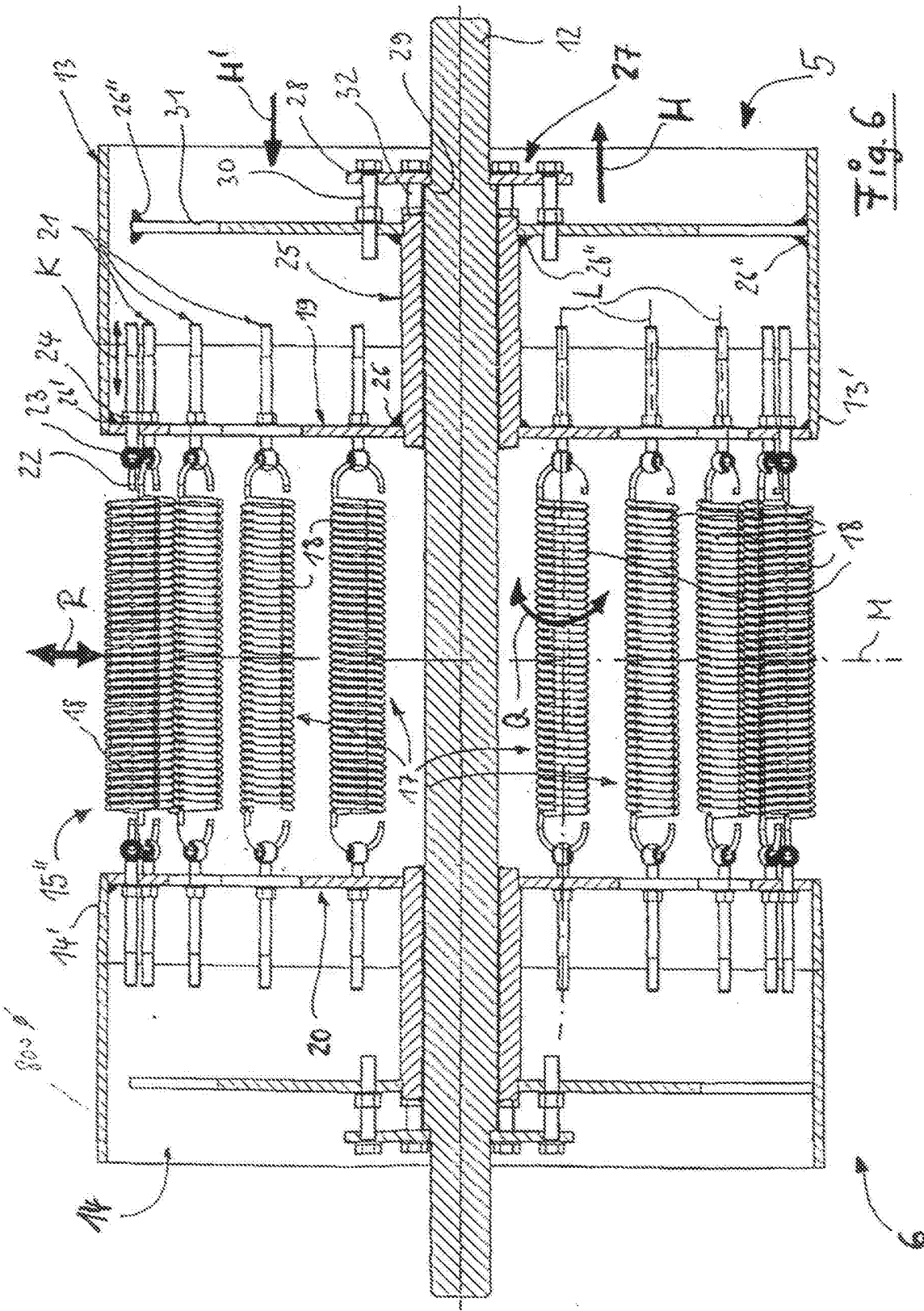

Fig. 6

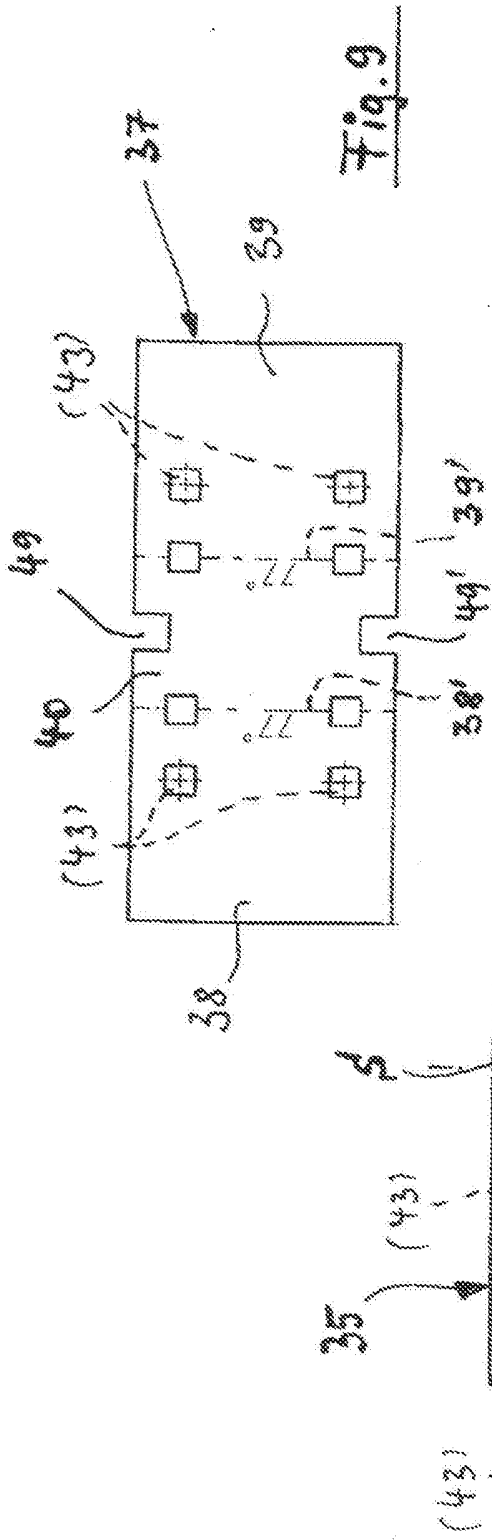

Fig. 9

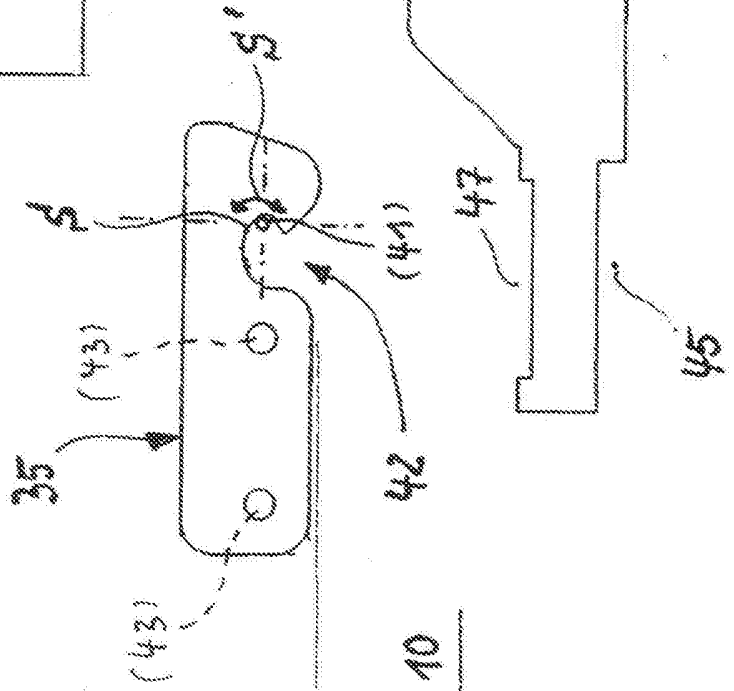

Fig. 10

Fig. 11