



Europäisches Patentamt
European Patent Office
Office européen des brevets



Publication number: **0 468 064 A1**

EUROPEAN PATENT APPLICATION

Application number: **90114037.6**

Int. Cl.⁵: **E06B 9/15, E06B 7/084**

Date of filing: **23.07.90**

Date of publication of application:
29.01.92 Bulletin 92/05

Applicant: **ITALSYSTEM S.r.l.**
Via degli Svevi, 175/A
I-88100 Catanzaro(IT)

Designated Contracting States:
AT BE CH DE DK ES FR GB GR LI LU NL SE

Inventor: **Mancuso, Giovanni**
Via Fontana Vecchia, 28
88100 Catanzaro(IT)

Representative: **Rapisardi, Mariacristina, Dr.**
Proc.
STUDIO TECNICO LEGALE RAPISARDI Largo
V Alpini 15
I-20145 Milano(IT)

Supporting element for orientable louver boards for shutters with simplified assembly.

The supporting element for orientable louver boards, for shutters with simplified assembly which comprise a hollow body (2) which has, on its two longer sides, variously shaped seats (3) (4) for coupling to other orientable louver boards of the shutter, comprises guiding means (6) and retention means (7) for associating a louver board with the supporting element itself along a direction which is substantially orthogonal to the axis of the louver board; the retention means are furthermore suitable for releasing the louver board from its respective supporting elements along two mutually orthogonal directions, one of which is substantially parallel to the axis of the louver board.

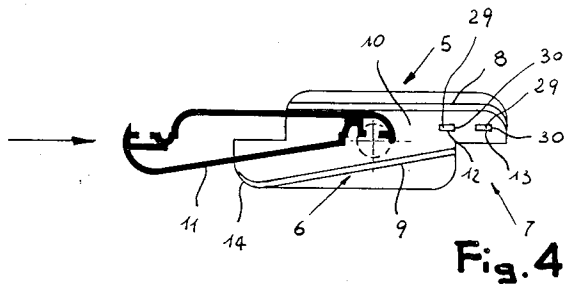

EP 0 468 064 A1

The present invention relates to a supporting element for orientatable louver boards for shutters with simplified assembly.

As is known, the installation of a shutter with orientatable louver boards usually initially entails the insertion of the louver board supporting elements into the ends of said louver boards along a direction which is substantially parallel to the axis of the louver boards and subsequently the association of the supporting elements, with the respective assembled louver boards, with the uprights of the frame of the shutter.

This assembly system has considerable disadvantages, the first of which is the fact that if the dimension of the frame of the shutter do not perfectly match the dimensions of the seat in which said shutter is to be mounted it is necessary to dismantle all the louver boards from their supports in order to replace them with longer louver boards or possibly shorten them to the required size.

Secondly, it can be easily understood that such an assembly of a shutter requires a certain skill and necessarily entails the use of specialized labor.

The aim of the present invention is to eliminate the above described disadvantages by providing a supporting element for orientatable louver boards for shutters with simplified assembly which can be coupled to the louver boards when the frame of the shutter is already assembled and can be uncoupled from said louver boards along a direction which differs from the assembly direction.

Within the scope of this aim, an important object of the invention is to provide a supporting element for orientatable louver boards for shutters with simplified assembly which effectively retains the louver boards once they are associated therewith.

Another object of the present invention is to provide an orientatable louver board for shutters in which, when the louver boards are in closed position, the regions of contact with the other louver boards define a perfect barrier to the passage of light.

Not least object is to provide a supporting element for orientatable louver boards which has no play once it is assembled to the louver boards.

This aim, these objects and others are achieved by a supporting element for orientatable louver boards for shutters with simplified assembly, which comprise a hollow body which has, on its two longer sides, variously shaped seats for coupling to other orientatable louver boards of the shutter, characterized in that it comprises guiding means and retention means for associating said louver board with said supporting element along a direction which is substantially orthogonal to the axis of said louver board, said retention means being adapted to release said louver board from

said supporting element along two mutually orthogonal directions, one of which is substantially parallel to said axis of said louver board.

Further characteristics and advantages of the invention will become apparent from the description of a preferred but not exclusive embodiment of the supporting element for orientatable louver boards for shutters with simplified assembly according to the invention, illustrated only by way of non-limitative example in the accompanying drawings, wherein:

figure 1 is a transverse sectional view of the louver board according to the invention;

figure 2 is another transverse sectional view of the association of two louver boards according to the invention in closed position;

figure 3 is an enlarged view of the region of coupling of the opposite ends of two adjacent louver boards and of the related sealing gasket;

figure 4 is a plan view of the insertion of an end of a louver board, along a direction which is substantially orthogonal to the axis of said louver board, into the supporting element;

figure 5 is a view of the coupling of the louver board to the related supporting element;

figure 6 is a plan view of a further embodiment of the supporting element according to the invention;

figure 7 is a partial lateral elevation view of the louver board, with the coupling element according to the invention inserted; and

figure 8 is a plan view of the coupling element according to the invention.

With particular reference to the above figures, each orientatable louver board for shutters with simplified assembly comprises a hollow body 2 which has, on its two longer sides, which are arranged to the right and to the left of the hollow body in the drawing, variously shaped seats, generally indicated by the reference numerals 3 and 4, adapted to couple to the other orientatable louver boards of the shutter, as illustrated in figure 2.

A supporting element 5 according to the invention is mounted on each end of the louver boards and is rotatably coupled to the lateral uprights of the shutter, which are not illustrated in the drawings.

Each of the supporting elements 5 has guiding means, generally indicated by the reference numeral 6, and retention means, indicated by 7, to allow the valid retention of the louver board to the supporting element along a direction which is sub-

stantially orthogonal to the axis of said louver board.

More in particular, the guiding means 6 comprise a first wall 8 and a second wall 9 which define between them a region 10 for the accommodation of the louver board; the configuration and width of said accommodation region are substantially equal to those of the cross section of the hollow body of the louver board.

The second wall 9 is furthermore inclined with respect to the first wall 5 by the same angle by which the corresponding surface 11 of the louver board is inclined.

The retention means 7 comprise at least one raised portion and more in particular two raised portions 12 and 13 which extend perpendicular from the accommodation region 10.

Each of said raised portions 12 and 13 has an upper wall 29 which is inclined so as to facilitate the insertion of the louver board in the supporting element and a wall 30 which is orthogonal to the accommodation region so as to provide a final locking to the supporting element by virtue of its engagement with the inner surface thereof.

In particular, the raised portion 12 engages within the hollow body 2, whereas the raised portion 13 engages within the seat 4 or, in a constructive variation, the raised portion 12 engages within the seat 3.

The second wall 9 furthermore has, on the opposite side with respect to the two raised portions 12 and 13, a curved end portion 14 the function whereof is to co-operate with the raised portions 12 and 13 to retain the louver board to the supporting element.

Finally, as can be seen in figure 2, when the seats 3 and 4 are mutually coupled during the closure of the louver boards, each seat has recessed parts 18 on one which are located at protruding parts 17 of the other, so as to define a labyrinth-like path which has at least two barrier regions and more precisely three barrier regions against the passage of light when the louver boards are in closed position.

A recess 15 for accommodating a sealing gasket 16 is furthermore advantageously provided in the seat 3; said gasket is defined by a first rod 19 from which a second rod 20 extends vertically; two wings 21 divergently extend from said second rod.

Conveniently, the wings 21 are simultaneously in contact with the shoulders 22 of two contiguous louver boards so as to provide a perfect seal, preventing the passage of dust or water as well as light.

In a different embodiment, the retention means comprise at least one coupling element 40 which has, on one side, a raised portion 41 adapted to be inserted within each louver board 2 and, on the

opposite side with respect to the raised portion 41, at least one pin, two pins 42 in the illustrated example, suitable for engaging snap-together in respective holes 43 provided in the supporting element when the louver board is associated therewith.

The pins 42 are conveniently associated with respective tabs 44 which are elastically yielding since they are coupled to the accommodation region 10 of the supporting element only with one of their sides.

In a further variation, the coupling element can also be provided without the two end portions 45 and 46 and therefore its exact placement on the supporting element is obtained by providing thereon two steps 47 and 48 which abut on the end portions 45 and 46 of the coupling element which are indicated in broken lines in figure 7.

The association of the louver board with the respective supporting element according to the invention is evident from which has been described and illustrated; in particular, with reference to figures 4 and 5, it can be seen that by moving the louver board along a direction which is substantially perpendicular to its longitudinal axis, also by virtue of the presence of the second wall 9, said louver board is guided until it is proximate to the raised portions 12 and 13 or to the holes 43 if the coupling element 40 is associated with the louver board.

By subsequently exerting a slight pressure, the raised portions 12 and 13, by virtue of the presence of an inclined wall on their face, respectively insert in the seat 4 and within the hollow body 2 or the seat 3 of the louver board, locking said louver board to the supporting element 5.

In the same manner, the pins 42 insert in the respective holes 43 if the coupling element 40 is associated with the louver board.

The curved end portion 14 of the second wall 6 furthermore co-operates to retain in place the louver board 1 within its accommodation region in the supporting element.

In practice it has been observed that the orientable louver board for shutters with simplified assembly according to the invention is particularly advantageous in that it allows the casement installer for example to couple a specimen louver board to the respective supporting element after mounting the shutter's frame, to check if the length of the louver board is exactly the preset one and thus confidently mount all the remaining louver boards on the respective supporting elements.

If instead the length of the louver board is not the preset one, it is possible to already preset the other louver boards with the right measurements without the disadvantage of having rejects.

The invention thus conceived is susceptible to

numerous modifications and variations, all of which are within the scope of the inventive concept; all the details may furthermore be replaced with technically equivalent elements.

In practice, the materials employed, as well as the dimensions, may be any according to the requirements and the state of the art.

Where technical features mentioned in any claim are followed by reference signs, those reference signs have been included for the sole purpose of increasing the intelligibility of the claims and accordingly such reference signs do not have any limiting effect on the scope of each element identified by way of example by such reference signs.

WHERE TECHNICAL FEATURES MENTIONED IN ANY CLAIM ARE FOLLOWED BY REFERENCE SIGNS, THOSE REFERENCE SIGNS HAVE BEEN INCLUDED FOR THE SOLE PURPOSE OF INCREASING THE INTELLIGIBILITY OF THE CLAIMS AND ACCORDINGLY, SUCH REFERENCE SIGNS DO NOT HAVE ANY LIMITING EFFECT ON THE SCOPE OF EACH ELEMENT IDENTIFIED BY WAY OF EXAMPLE BY SUCH REFERENCE SIGNS.

Claims

1. Supporting element for orientatable louver boards for shutters with simplified assembly, comprising a hollow body (2) which has, on the two longer sides, variously shaped seats (3) (4) for coupling to other orientatable louver boards of the shutter, characterized in that it comprises guiding means (6) and retention means (7) for associating said louver board with said supporting element along a direction which is substantially orthogonal to the axis of said louver board, said retention means being adapted to release said louver board from said supporting element along two mutually orthogonal directions, one of which is substantially parallel to said axis of said louver board.
2. Supporting element according to claim 1, characterized in that said guiding means comprise a first wall (8) and a second wall (9) which define between them a region (10) for the accommodation of said louver board, said region being substantially equal to the width of the cross section of said hollow body.
3. Supporting element according to claim 1, characterized in that said second wall (9) has, with respect to said first wall (8), an inclination which is identical to the inclination of the corresponding surface (11) of said louver board.
4. Supporting element according to claim 1, characterized in that said retention means comprise at least one raised portion (12) (13) which extends from said accommodation region (10) and has an inclined wall (29), said raised portion engaging an inner surface of said louver board.
5. Supporting element according to claim 3, characterized in that said second wall has, on the side opposite to said raised portion, a curved end portion (14) which co-operates with said raised portion to retain said louver board in said accommodation region.
6. Supporting element according to claims 1 and 2, characterized in that said retention means comprise at least one coupling element (40) which has, on one side, a raised portion (41) which engages in each of said louver boards and, on the opposite side, at least one pin (42) which elastically engages in a corresponding hole (43) which is provided in said accommodation region.
7. Supporting element according to claim 6, characterized in that said at least one pin is supported by an elastic tab (44) which is associated with said coupling element.
8. Supporting element according to one or more of the preceding claims, characterized in that said supporting element has two opposite steps (47,48) for the placement of the coupling element without its end portions. (45,46)
9. Louver board according to claim 1, characterized in that each of said variously shaped seats has accommodation seats for a sealing gasket and recessed parts (18) on one at protruding parts (17) of the other so as to define a labyrinth-like path which has at least two barrier regions against the passage of light when the laminas are in the position for closing said shutter.
10. Louver board according to claim 6, characterized in that said sealing gasket has a rod (19) from which a second rod (20) extends vertically, two wings (21) divergently extending from the end of said second rod.

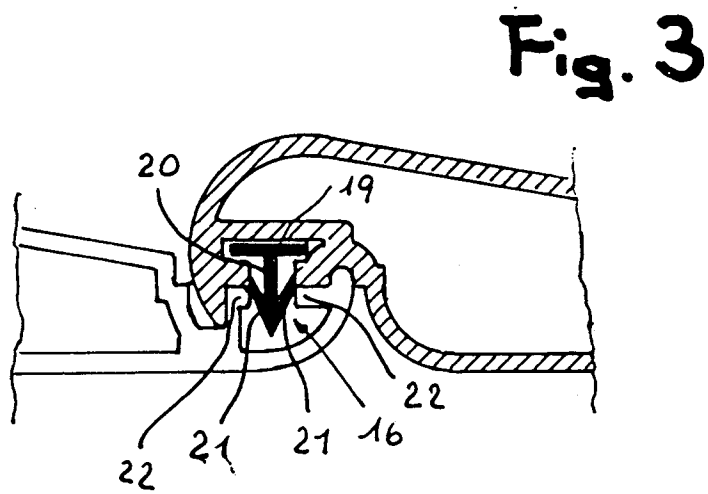
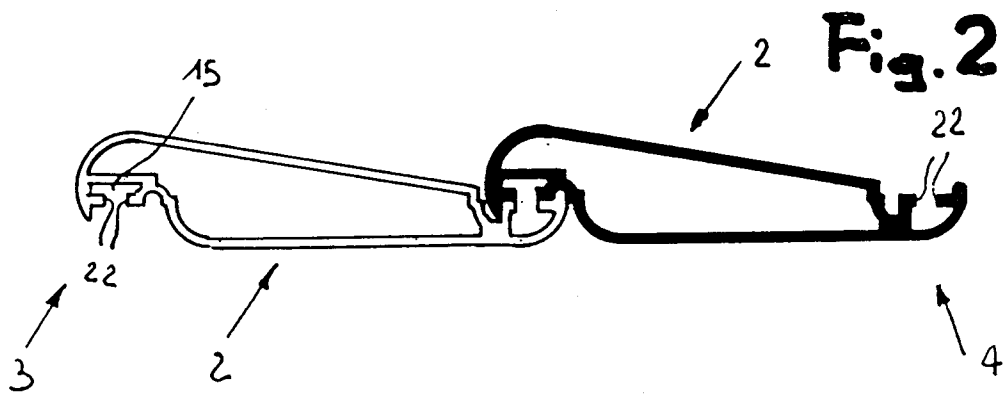
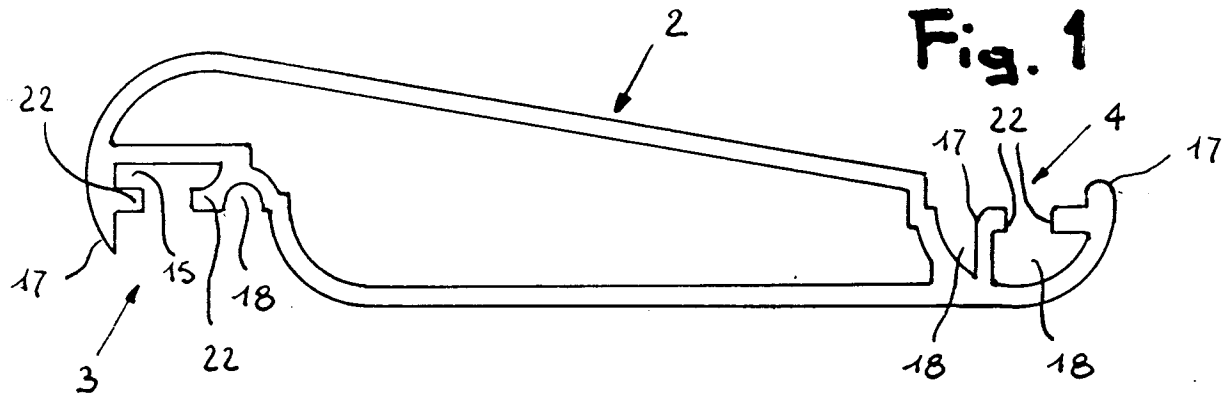

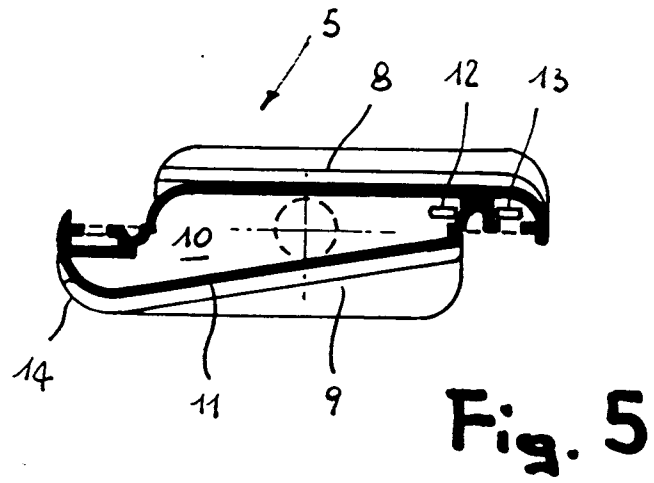
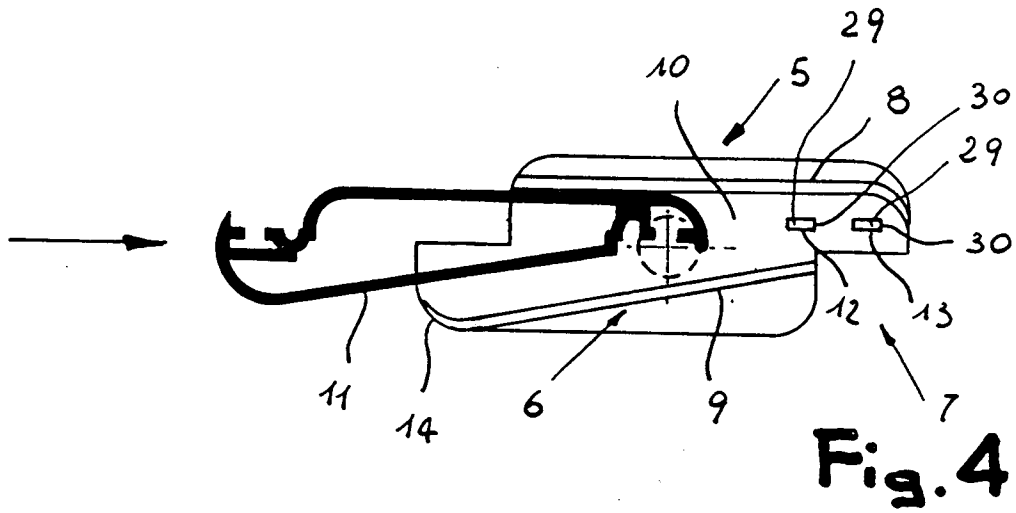

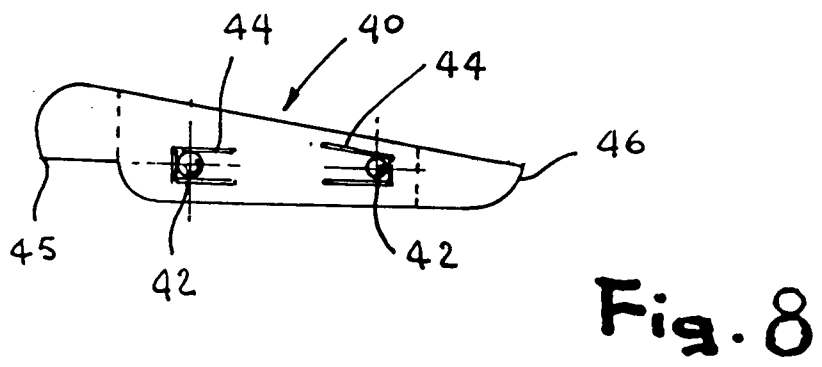
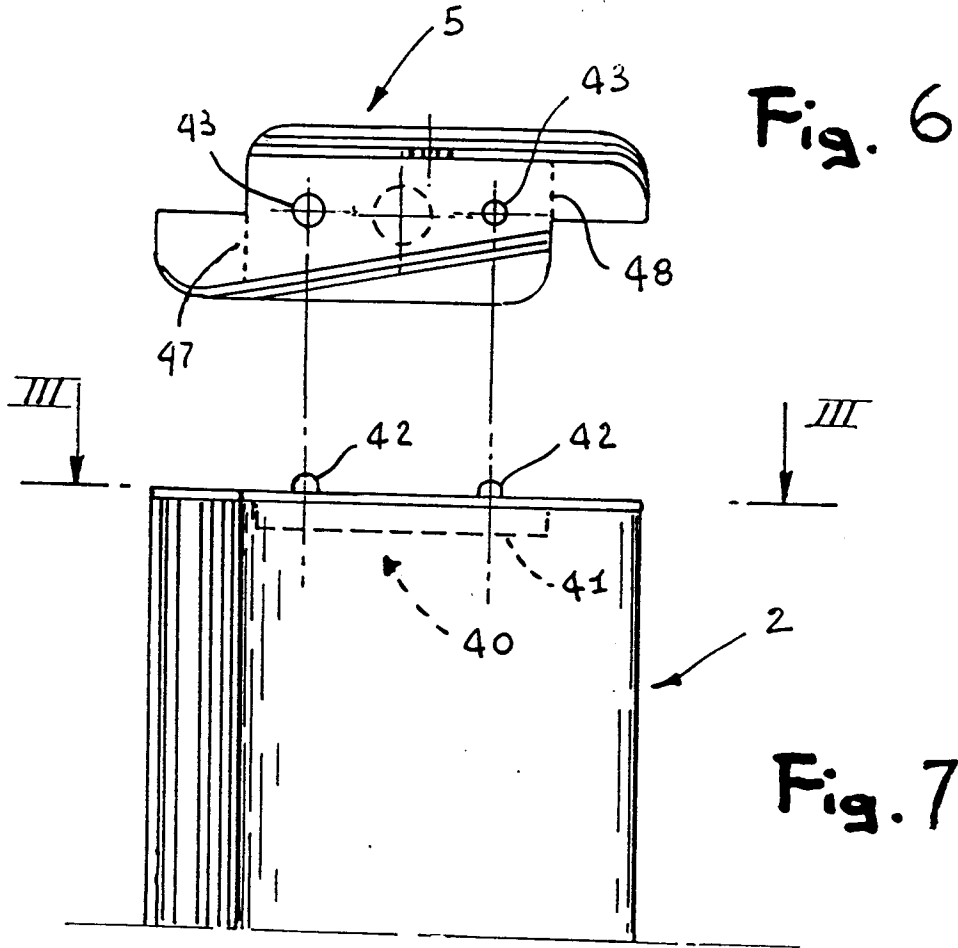



EUROPEAN SEARCH
REPORT

DOCUMENTS CONSIDERED TO BE RELEVANT

Category	Citation of document with indication, where appropriate, of relevant passages	Relevant to claim	CLASSIFICATION OF THE APPLICATION (Int. Cl.5)
A	CH-A-425 165 (E. TOBLER) * complete document * - - -	1,6	E 06 B 9/15 E 06 B 7/084
A	AU-B-532 274 (CHRIS TURNER AND SCOTT PTY. LTD.) * complete document * - - -	1,6,9	
A	DE-U-1 897 147 (A. CRUDUP) * figures 2,3; page 4, paragraph 1 * - - - - -	9	
			TECHNICAL FIELDS SEARCHED (Int. Cl.5)
			E 06 B
The present search report has been drawn up for all claims			
Place of search		Date of completion of search	Examiner
Berlin		20 March 91	KRABEL A.W.G.
<p>CATEGORY OF CITED DOCUMENTS</p> <p>X: particularly relevant if taken alone Y: particularly relevant if combined with another document of the same category A: technological background O: non-written disclosure P: intermediate document T: theory or principle underlying the invention</p> <p>E: earlier patent document, but published on, or after the filing date D: document cited in the application L: document cited for other reasons &: member of the same patent family, corresponding document</p>			