



(72) ENDERS, MARTIN, DE

(71) PATENT-TREUHAND-GESELLSCHAFT FÜR ELEKTRISCHE
GLUEHLAMPEN MBH, DE

(51) Int.Cl.⁷ B60Q 1/26

(30) 1999/05/26 (199 23 919.3) DE

(54) **LAMPE POUR VEHICULES AUTOMOBILES**

(54) **MOTOR VEHICLE LAMP**

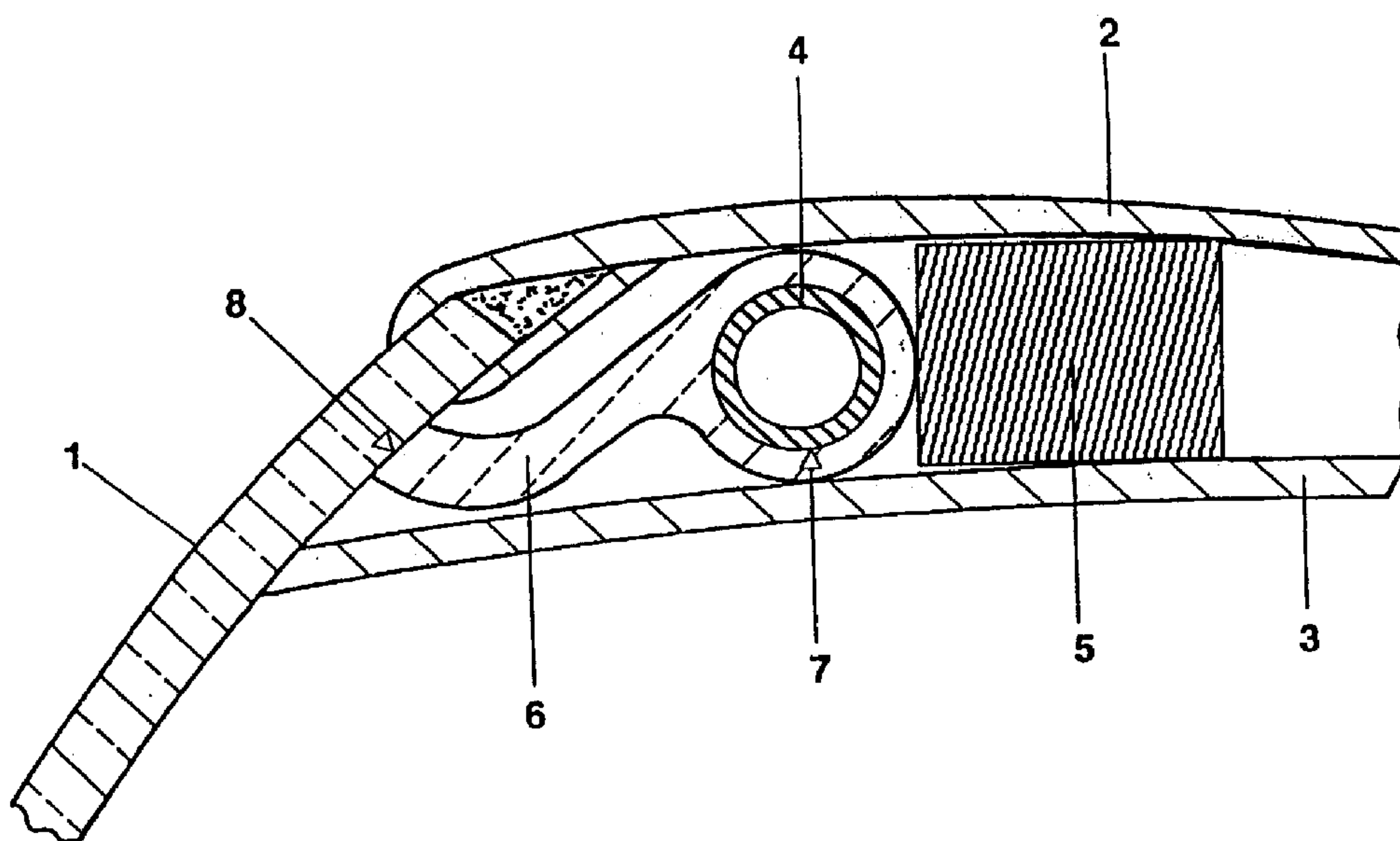

(57) The invention relates to a motor vehicle lamp having a light source (4), at least one optical conductor (6) which is optically coupled to the light source (4), and operating means (5) for the light source (4). The optical conductor (6) has a light exit surface (8) whose curvature is adapted according to the invention to the curvature of the motor vehicle.

Abstract

Motor vehicle lamp

The invention relates to a motor vehicle lamp having a light source (4), at least one optical conductor (6) which is optically coupled to the light source (4), and operating means (5) for the light source (4). The optical conductor (6) has a light exit surface (8) whose curvature is adapted according to the invention to the curvature of the motor vehicle.

Motor vehicle lamp

The invention relates to a motor vehicle lamp in
5 accordance with the preamble of patent claim 1.

I. Summary of the invention

10 It is the object of the invention to provide a motor
vehicle lamp which can be used independently of the
form of the light source in the motor vehicle.

This object is achieved according to the invention by
15 the distinguishing features of patent claim 1.
Particularly advantageous designs of the invention are
described in the subclaims.

The motor vehicle lamp according to the invention has a
20 light source, at least one optical conductor which is
optically coupled to the light source, and operating
means for the light source. According to the invention,
the optical conductor has a light exit surface whose
curvature is adapted to the curvature of the motor
25 vehicle. The abovenamed features permit the motor
vehicle lamp according to the invention to be fitted
with commercially available light sources and operating
means and to be adapted with simple means to different
vehicle shapes. To adapt the lamp according to the
30 invention to the motor vehicle shape, it suffices to
fit the shape of the at least one optical conductor, in
particular the curvature of its light exit surface, to
the configuration of the corresponding motor vehicle
area.

35

In accordance with the particularly preferred exemplary
embodiments of the invention, the curvature of the

- 2 -

light exit surface of the optical conductor is adapted to the contour of the vehicle rear window or to the contour of the vehicle body. It is possible thereby to implement stop lamps and turn signal lamps which are
5 fitted with commercially available lamps and optimally coordinated with the vehicle shape.

It is advantageous to use a neon gas discharge lamp or a fluorescent lamp as a light source. These lamps have
10 a high light yield and a long service life, and can be produced with small dimensions. Moreover, red or orange light can be produced in a simple way with their aid. A commercially available electronic ballast is advantageously used as operating means for the
15 abovenamed lamps. Such ballasts are distinguished by a compact design. In order to ensure light is coupled as effectively as possible into the at least one optical conductor, the at least one optical conductor is provided with a tubular cutout for holding the light
20 source. The diameter of the cutout is preferably coordinated with the dimensions of the light source. In order to improve the electromagnetic compatibility of the motor vehicle lamp according to the invention, the electronic ballast is fitted with an electrically
25 conducting layer or foil or with a metal housing which is connected to frame potential or ground potential. Moreover, for the same purpose the lamp or/and the at least one optical conductor is provided with an electrically conducting layer or foil which is
30 connected to frame potential or ground potential.

II. Description of the preferred exemplary embodiment

35 The invention is explained in more detail below with the aid of a preferred exemplary embodiment. In the drawing:

- 3 -

Figure 1 shows a cross section through a motor vehicle lamp according to the invention, in accordance with a preferred exemplary embodiment of the invention, and

5

Figure 2 shows a schematic plan view of the exemplary embodiment illustrated in Figure 1.

The preferred exemplary embodiment, illustrated in Figures 1 and 2, of the invention is a high-level stop lamp which is arranged on the upper edge of the vehicle rear window 1. The stop lamp is arranged in the interspace between the vehicle roof 2 and the roofliner 3. It comprises a tubular neon gas discharge lamp 4, a commercially available electronic ballast 5 for operating the lamp 4, and an optical conductor 6. The tubular neon gas discharge lamp 4 is arranged in a cutout 7 in the optical conductor 6, whose diameter is coordinated to fit with the outside diameter of the neon gas discharge lamp 4. The optical conductor 6 has an elongated light exit surface 8 whose curvature is adapted to the curvature of the rear window 1. The light exit surface 8 of the optical conductor 6 bears in a self-closed fashion against the rear window 1. In order to improve the electromagnetic compatibility of the stop lamp, the lamp vessel of the neon gas discharge lamp 4 is provided with a transparent electrically conductive indium tin oxide layer (ITO layer) which is connected to the frame potential of the ballast 5. For the purpose of protection and of achieving the effect of optical conduction and of launching the light into the optical conductor 6 as well as improving the electromagnetic compatibility of the lamp, the outer surface of the optical conductor 6 is provided with an electrically conducting, optically reflecting coating, which is likewise connected to the frame potential of the ballast 5. Moreover, likewise for the purpose of improving the electromagnetic

35

- 4 -

compatibility, the inner wall of the ballast housing is metalized and connected to the frame potential of the ballast 5.

5 The invention is not limited to the exemplary embodiment described in more detail above. The motor vehicle lamp according to the invention can also be designed, for example in the case of a convertible, as a stop lamp which is arranged on the vehicle tailgate.

10 In this case, the curvature of the light exit surface of the optical conductor is adapted to the contour or shape of the tailgate. The associated lamp and the ballast required for operating the lamp are arranged, for example, on the inner wall of the tailgate. The

15 motor vehicle lamp according to the invention can, however, also be designed as a turn signal lamp which is arranged in the rear or front region of the vehicle. In this case, the curvature of the light exit surface of the optical conductor is adapted to the contour of

20 the vehicle rear region or front region.

THE EMBODIMENTS OF THE INVENTION IN WHICH AN EXCLUSIVE PROPERTY OR PRIVILEGE IS CLAIMED ARE DEFINED AS FOLLOWS

1. A motor vehicle lamp having a light source (4), at least one optical conductor (6) which is optically coupled to the light source (4), and operating means (5) for the light source (4), wherein the at least one optical conductor (6) has a light exit surface (8) whose curvature is adapted to the curvature of the motor vehicle.
5
- 10 2. The motor vehicle lamp as claimed in claim 1, wherein the curvature of the light exit surface (8) of the at least one optical conductor (6) is adapted to the contour of the vehicle rear window (1).
15
3. The motor vehicle lamp as claimed in claim 1, wherein the curvature of the light exit surface of the at least one optical conductor is adapted to the contour of the vehicle body.
20
4. The motor vehicle lamp as claimed in claim 1, wherein the light source (4) is a neon gas discharge lamp or a fluorescent lamp.
25
5. The motor vehicle lamp as claimed in claim 4, wherein the operating means (5) are designed as an electronic ballast.
- 30 6. The motor vehicle lamp as claimed in claim 1, wherein the at least one optical conductor (6) has a tubular cutout (7) for holding the light source (4).
- 35 7. The motor vehicle lamp as claimed in claim 2, wherein the motor vehicle lamp has a flat design to the effect that it can be inserted between the

- 6 -

metal roof (1) and the roofliner (3) of the motor vehicle.

- 5 8. The motor vehicle lamp as claimed in claim 5 or 6, wherein the electronic ballast (5) and the lamp (4) or the at least one optical conductor (6) have an electrical layer or foil which are connected to frame potential or ground potential.

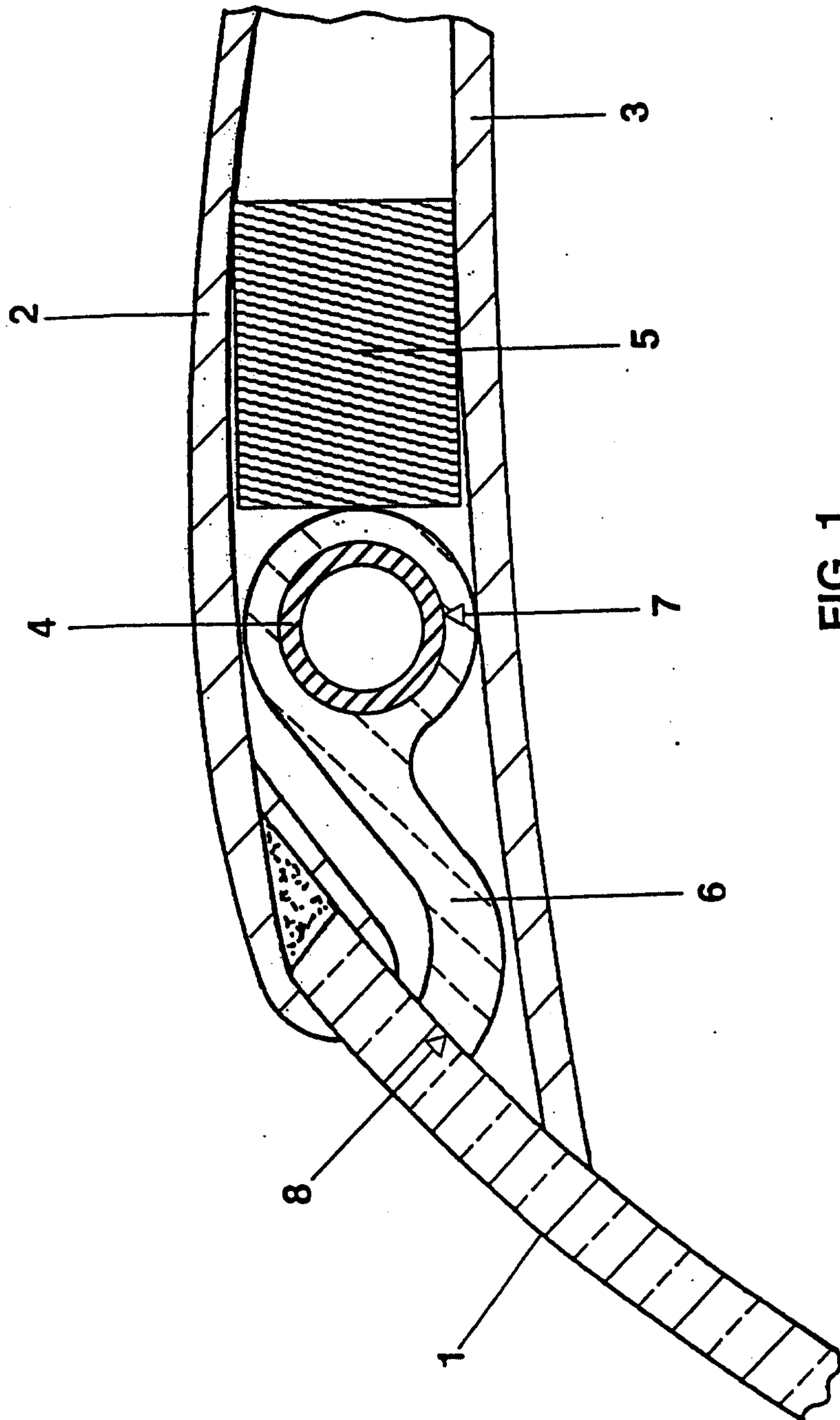

FIG. 1

Patent Agents
Tetherstonhaugh & Co.

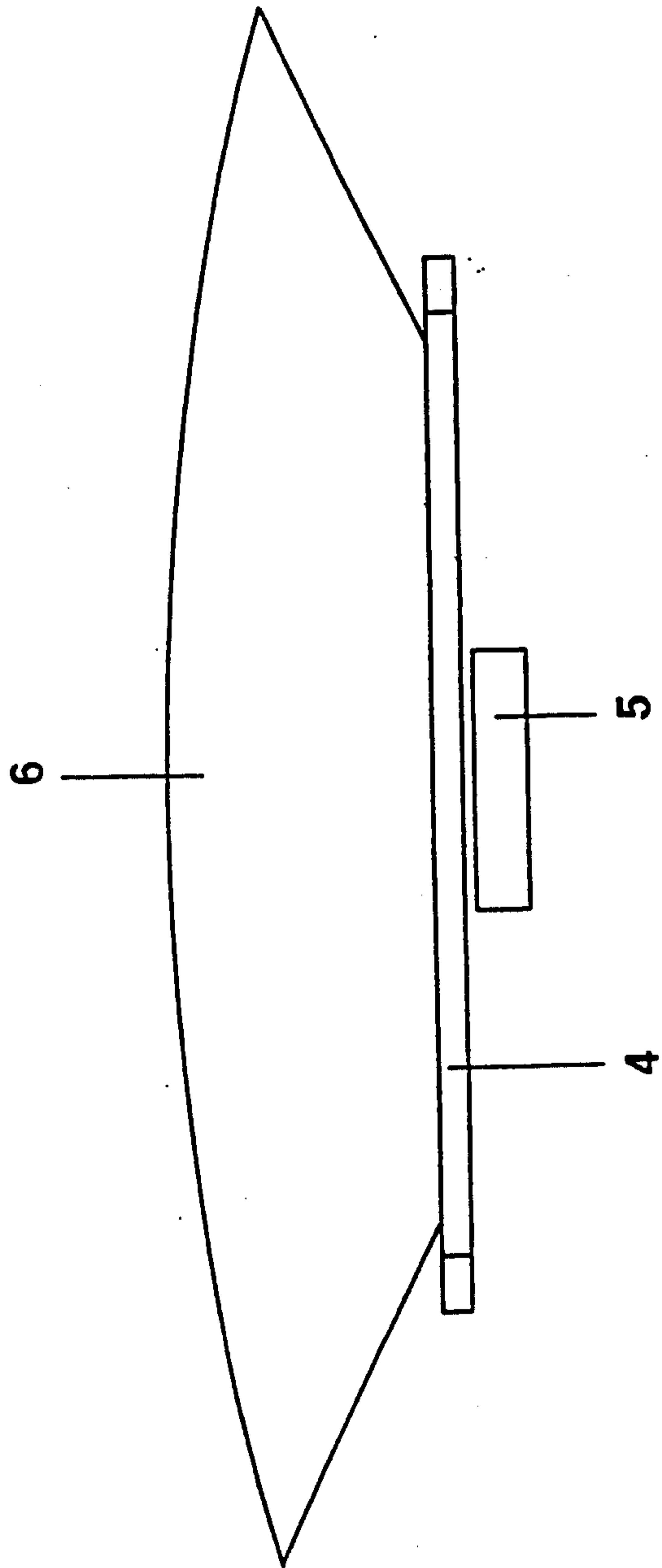

FIG. 2

Patent Agents
Fetherstonhaugh & Co.

