



INTERNATIONAL APPLICATION PUBLISHED UNDER THE PATENT COOPERATION TREATY (PCT)

(51) International Patent Classification ⁵ : B65D 25/08	A1	(11) International Publication Number: WO 92/06898 (43) International Publication Date: 30 April 1992 (30.04.92)
(21) International Application Number: PCT/US91/07588 (22) International Filing Date: 9 October 1991 (09.10.91) (30) Priority data: 095,985 15 October 1990 (15.10.90) IL (71) Applicant: G.L.K. INTERNATIONAL, INC. [US/US]; The Atrium, 1900 Market Street, Philadelphia, PA 19103 (US). (72) Inventors: LEV, Shlomo ; 25, Aronowitz Street, Holon (IL). KOGAN, Baruch ; 14, Sheftel Street, Rishon Lezion (IL). (74) Agent: FAIGUS, Martin, L.; Caesar, Rivise, Bernstein, Cohen & Pokotilow, Ltd., 12th Floor, Seven Penn Center, 1635 Market Street, Philadelphia, PA 19103-2212 (US).		(81) Designated States: AT (European patent), AU, BE (European patent), BR, CA, CH (European patent), DE (European patent), DK (European patent), ES (European patent), FR (European patent), GB (European patent), GR (European patent), IT (European patent), JP, LU (European patent), NL (European patent), SE (European patent). Published <i>With international search report.</i>

(54) Title: MULTI-COMPARTMENT LIQUID STORAGE CONTAINER

(57) Abstract

A multi-compartment liquid storage container (10) capable of separately storing two or more liquids which may become mixed upon pouring. The storage container comprises a primary container (10) with an internal container (16) of smaller diameter within the hollow of the primary container thus creating an additional storage compartment (18). Removal of the pull-tab (12) provided on the primary container (10) enables access to the contents of the primary container (10) and the additional storage compartment (18). In an alternative embodiment, the primary container (10) is provided with a non-removable lift-tab (40) and a penetrable foil section (44) is provided in the wall of the internal container (16). The lift-tab (40) perforates the foil (44) during the opening procedure to provide internal container access.

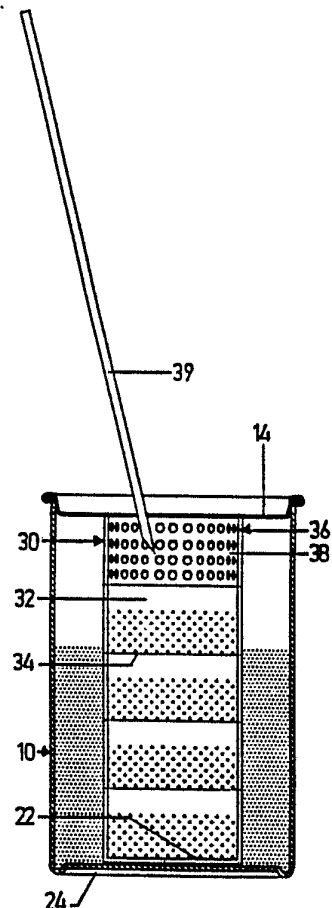

FOR THE PURPOSES OF INFORMATION ONLY

Codes used to identify States party to the PCT on the front pages of pamphlets publishing international applications under the PCT.

AT	Austria	ES	Spain	MG	Madagascar
AU	Australia	FI	Finland	ML	Mali
BB	Barbados	FR	France	MN	Mongolia
BE	Belgium	GA	Gabon	MR	Mauritania
BF	Burkina Faso	GB	United Kingdom	MW	Malawi
BG	Bulgaria	GN	Guinea	NL	Netherlands
BJ	Benin	GR	Greece	NO	Norway
BR	Brazil	HU	Hungary	PL	Poland
CA	Canada	IT	Italy	RO	Romania
CF	Central African Republic	JP	Japan	SD	Sudan
CG	Congo	KP	Democratic People's Republic of Korea	SE	Sweden
CH	Switzerland	KR	Republic of Korea	SN	Senegal
CI	Côte d'Ivoire	LI	Liechtenstein	SU ⁺	Soviet Union
CM	Cameroon	LK	Sri Lanka	TD	Chad
CS	Czechoslovakia	LU	Luxembourg	TG	Togo
DE*	Germany	MC	Monaco	US	United States of America
DK	Denmark				

+ Any designation of "SU" has effect in the Russian Federation. It is not yet known whether any such designation has effect in other States of the former Soviet Union.

MULTI-COMPARTMENT LIQUID STORAGE CONTAINERField of the Invention

The present invention relates to liquid storage containers, and more particularly to a liquid storage container having multiple compartments for storing a plurality of different liquids intended for mixing upon pouring.

Background of the Invention

There are known various types of containers for the storage of liquids comprising a single substance. Such containers are generally produced from aluminum, plastic or glass materials, forming a single compartment for the storage of the liquid. The shape of the container and the types of liquids stored therein vary widely, however, a common characteristic is that the container consists of a single storage compartment and therefore is limited to the storage of only one type of liquid at a time.

There are, however, cases in which it would be advantageous to store two or more kinds of liquids simultaneously in one container. This is particularly so when dealing with liquids of different types or those which comprise incompatible chemical substances that should not be mixed during storage. While such liquids may be intended for mixing, this does not occur prior to actual usage.

Existing storage containers could not, for example, be utilized for the separate storage of two or more ingredients required for the preparation of a cocktail drink, such as gin and tonic or tomato juice and vodka. Similarly, there are medical prescriptions which consist of two or more liquids which require mixing prior to usage. In both cases, separate storage is required and this generally involves producing two or more containers, each storing one type of liquid.

Thus, it would be desirable to provide a multi-compartment container allowing for simultaneous storage of different liquids which are intended for mixing upon pouring.

Summary of the Invention

Accordingly, it is a principal object of the invention to overcome the limitations of the existing single compartment liquid storage container and provide a multi-compartment

container capable of simultaneously storing two or more liquids intended for mixing upon pouring.

In accordance with a preferred embodiment of the present invention, there is provided a multi-compartment liquid storage container comprising a container having a plurality of storage compartments each capable of separately storing a different liquid, said different liquids becoming mixed when poured during removal from said container.

In a preferred embodiment of the invention, the inventive storage container comprises a primary container with an internal container of smaller diameter set in the cylindrical hollow of the primary container, thus creating an additional storage compartment. The primary storage container is provided with a removable pull tab. Removal of the pull-tab enables access to the contents of the primary container and the additional storage compartment.

The internal container is fixedly attached to the bottom of the primary container and is sealed at the top in part by the primary container and in part by the pull-tab attached thereto. Opening of the primary container by removal of the pull-tab allows for immediate access to the liquids contained in both primary and internal containers.

In an alternative embodiment, the primary container is provided with a non-removal lift-tab opening. In this arrangement, a penetrable foil section is provided in the wall of the internal container. The lift-tab perforates the foil during the opening procedure to provide internal container access.

In another alternative embodiment of the invention, the internal container is sub-divided by additional compartments each sealed off from the other by a penetrable foil membrane, thus allowing for separate storage of a plurality of liquids simultaneously. This alternative embodiment of the invention may be provided in combination with either a removable pull-tab or non-removable lift-tab opening. A straw may be used to perforate the membrane between the sections, allowing access to the liquids.

In still another alternative embodiment, the inventive container has a plurality of access openings, each opening allowing access to a separate storage compartment. When the access

openings are opened together, the liquids may be simultaneously poured and mixed.

Various container constructions using different materials are possible, including metal containers (coated tin, aluminum, etc.), glass bottles, paper or cardboard containers, or combinations of these materials.

In addition to container constructions using a pull-tab for sealing, various closures are possible, including the vacuum-sealed twist-cover type, and the aluminum foil cover which can be peeled off and removed.

The inventive container design enables separate liquid storage in many applications, including pre-measured cocktail mixes and medicinal preparations.

Additional features of the invention will become apparent from the following drawing and description.

Brief Description of the Drawings

For a better understanding of the invention with regard to the embodiments thereof, reference is made to the accompanying drawings, in which like numerals designate corresponding elements or sections throughout and in which;

Fig. 1 is a perspective view of a preferred embodiment of a multi-compartment liquid storage container constructed in accordance with the principles of the invention;

Fig. 2a is an exploded perspective view of the container of Fig. 1 showing an internal storage container;

Fig. 2b is a perspective view of the subdivided internal storage container, as an alternative for use in Fig. 2a;

Fig. 3a is a top view of the container of Fig. 1 showing a removable pull-tab construction;

Figs. 3b-3c are respectively, cross-sectional side views of the container of Figs. 1-2a, b showing a single and subdivided internal storage container;

Fig. 4a is an exploded perspective view of an alternative embodiment of the container of Fig. 1, featuring a non-removable lift-tab;

Fig. 4b is a top view of the container of Fig. 4a;

Fig. 4c is a cross-sectional side view of the container of Fig. 4a showing a single internal storage container;

Fig. 4d is a cross-sectional side view of the container of Fig. 4a showing a subdivided internal storage container; and

Fig. 5 is an exploded perspective view of another alternative embodiment, showing a partition and two container access openings for pouring the contents of multiple compartments.

Detailed Description of the Preferred Embodiments

Referring to Fig. 1, there is shown an illustration of a multi-compartment liquid storage container 10 having an opening arrangement comprising a pull-tab 12 disposed in the top wall 14. Removal of pull-tab 12 reveals the outer wall 15 of an internal storage container 16 which defines a primary storage compartment 17 and an internal storage compartment 18. Container 10 is of a well-known standard construction and is generally made of aluminum or thin sheet metal. Container 10 is commonly used by manufacturers of a wide variety of liquid beverage drinks.

It will be appreciated that various container constructions using different materials are possible, including glass, paper or cardboard, or combinations of these materials.

Fig. 2a shows an illustration of an exploded perspective view where internal storage container 16 is a cylindrically-shaped container of smaller diameter than the primary container 10 and is set in the cylindrical hollow 20 of the primary container 10. The internal container 16 is fixedly attached at its bottom section 22 to the primary container 10 bottom wall 24 and sealed at its top rim 26 in part by the top wall 14 of primary container 10 and in part by the underside of pull-tab 12. Alternatively, the bottom section 22 of internal container 16 is not fixedly attached to bottom wall 24.

In the normally closed position, pull-tab 12 seals aperture 28. Upon removal of pull-tab 12, the liquids stored in both primary storage container 10 and internal storage container 16 are accessible. Thus, once pull-tab 12 has been removed, the liquid contents stored in primary container 10 and internal storage container 16 may be immediately poured and mixed.

Fig. 2b shows a subdivided internal storage container 30 which may be provided as an alternative to internal storage container 16. Container 30 is provided with additional sub-

divided compartments 32 each sealed from the other by a penetrable foil membrane 34. The alternative embodiment of Fig. 2b enables simultaneous storage of a plurality of liquids. These liquids may be accessed upon removal of tab 12 via aperture 28 by tearing penetrable foil membranes 34, thus allowing removal of the liquid contents stored in each of subdivided compartments 32.

Fig. 2b also illustrates an additional feature of the alternative embodiment, whereby the top section 36 of the container 30 is provided with perforations 38. This section of container 30 does not store liquid. The perforations 38 in top section 36 are designed to facilitate the pouring procedure in the preferred embodiment of Fig. 1 by facilitating the passage of air during the pouring procedure, causing turbulence and mixing.

Fig. 3a is a top view of primary container 10 shown in Fig. 1 incorporating a removable pull-tab 12 construction. It will be appreciated that in addition to the pull-tab construction, various other closures are possible, including the vacuum sealed twist-cover type, and aluminum foil cover which can be peeled off and removed.

Fig. 3b is a cross-sectional side view of the preferred embodiment described in Fig. 2a illustrating simultaneous liquid storage in both primary container 10 and in internal storage container 16. Internal storage container 16 is fixedly attached at its bottom section 22 to primary container bottom wall 24 as shown in Fig. 2a, and is positioned in cylindrical hollow 20 of primary container 10 such that upon removal of pull-tab 12, simultaneous access is provided to the liquid contents of primary and internal storage containers 10, 16.

Fig. 3c illustrates a cross-sectional side view of subdivided internal storage container 30 where each compartment 32 thereof contains and stores a separate liquid. Subdivided compartments 32 are sealed from each other by a penetrable foil membrane 34 as described with respect to the Fig. 2b embodiment. A straw 39 may be used to tear the membranes 34 to allow the contents of compartments 32 to be immediately poured and mixed.

Fig. 4a is an exploded perspective view of an alternative embodiment of the primary container 10 of Fig. 1 featuring a non-removable lift-tab 40. Upper side wall portion 42 of

internal storage container 16 features a penetrable foil membrane 44 which may be penetrated during the lift-tab opening procedure, enabling simultaneous access to the liquid contents of primary container 10 and internal storage container 16.

In Fig. 4b, a top view of primary storage container 10 is shown with a non-removable lift-tab arrangement and in Fig. 4c, a cross-sectional side view is shown, revealing internal storage container 16 and the foil membrane 44 in upper side wall portion 42. During the lift-tab 40 opening procedure, the tip 46 of lift-tab 40 presses against foil membrane 44, tearing it, and allowing access to the liquid contents of internal storage container 16.

Fig. 4d illustrates a cross-sectional side view of primary container 10 in an alternative embodiment providing the subdivided internal storage container 30 shown in Fig. 2b in combination with the non-removable lift-tab 40 shown in Fig. 4c.

In the cross-sectional side view of Fig. 4d, subdivided internal storage container 30 is shown offset from the center of primary storage container 10. This is to allow the tip 46 of lift-tab 40 to clear the top section 36 and perforations 38. Straw 39 is then used to penetrate the membranes 34, allowing the contents of compartments 32 to be poured out.

In Fig. 5, there is shown an exploded view of another alternative embodiment of container 10, with an interior partition 50 dividing the cylindrical hollow 20 into a plurality of compartments 52 and 54, each of which may store a separate liquid. Top wall 14 is provided with a plurality of pull-tabs 12, each providing access to a respective one of compartments 52, 54.

Interior partition 50 may be sealed on the upper edge 56 thereof to the underside of top wall 14 by use of an appropriate sealing material. Thus, when pull-tabs 12 are removed, the contents of compartments 52, 54 may be poured and mixed simultaneously. Interior partition 50 may be modified as needed to provide more than two internal compartments.

In accordance with the principles of the invention, primary storage container 10 and internal storage containers 16, 30 or compartments 52, 54 allow for separate storage of a

plurality of liquids, which can be immediately mixed upon opening container 10, using either the closing arrangement of pull-tab 12 or that of lift-tab 40. This provides many advantages and can be applied to mixtures for beverages, such as cocktail mixes, or for medicinal preparations, for example.

It will be appreciated that methods of filling container 10 with liquids in the storage compartments may vary, and will be adapted as needed in accordance with the particular container 10 design.

While the principles of the invention have been described with regard to particular embodiments, it is to be understood that the description is made by way of example only and not as a limitation on the scope of the invention which is set forth in the appended claims.

CLAIMS

We claim:

1. A multi-compartment liquid storage container comprising a container having a plurality of storage compartments each capable of separately storing a different liquid, said different liquids becoming mixed when poured during removal from said container.

2. The container of Claim 1 wherein at least two of said plurality of storage compartments are defined by a cylindrical internal container wall centered within said container, forming primary and internal storage containers.

3. The container of Claim 2 wherein a single access opening of said container is arranged to provide access to both said primary and internal storage containers.

4. The container of Claim 2 wherein said internal storage container is further subdivided by a plurality of foil membranes which can be torn to allow access to the contents of each compartment individually.

5. The container of Claim 2 wherein an upper portion of said internal container wall is perforated to allow for passage of said liquid therethrough when poured, causing turbulence.

6. The container of Claim 3 wherein said access opening comprises a pull-tab sealing an aperture in communication with said plurality of storage compartments.

7. The container of Claim 3 wherein said access opening comprises a non-removable lift-tab sealing an aperture, said lift tab perforating a foil membrane between at least two of said storage compartments during an opening procedure.

8. The container of Claim 1 wherein each of said plurality of storage compartments is provided with a respective individual access opening.

9. The container of Claim 3 wherein said access opening comprises a twist-cover sealing an aperture in communication with said plurality of storage compartments.

10. The container of Claim 3 wherein said access opening comprises a peelable foil cover sealing an aperture in communication with said plurality of storage compartments.

11. A multi-compartment liquid storage container comprising a container having a plurality of storage compartments each capable of separately storing a different liquid, said plurality of storage compartments sharing a normally sealed access opening, said different liquids becoming mixed when poured during removal from said container via said shared access opening when opened.

12. The container of Claim 11 as manufactured of metal.

13. The container of Claim 11 as manufactured of glass.

14. The container of Claim 11 as manufactured of paper.

15. The container of Claim 11 wherein said liquids are components of a cocktail mix.

16. The container of Claim 11 wherein said liquids are components of a medicinal preparation.

17. A method of separately storing a plurality of liquids simultaneously in a storage container for mixing during removal, said method comprising the steps of:

providing a storage container having a plurality of separate compartments sharing a normally sealed common access opening;

providing access to said plurality of separate compartments through said common access opening; and

pouring said plurality of liquids through said common access opening such that they become mixed.

18. The method of Claim 17 wherein at least one of said plurality of separate compartments has subdivided compartments and said step of providing access to said plurality of separate compartments includes the step of providing access to said subdivided compartments.

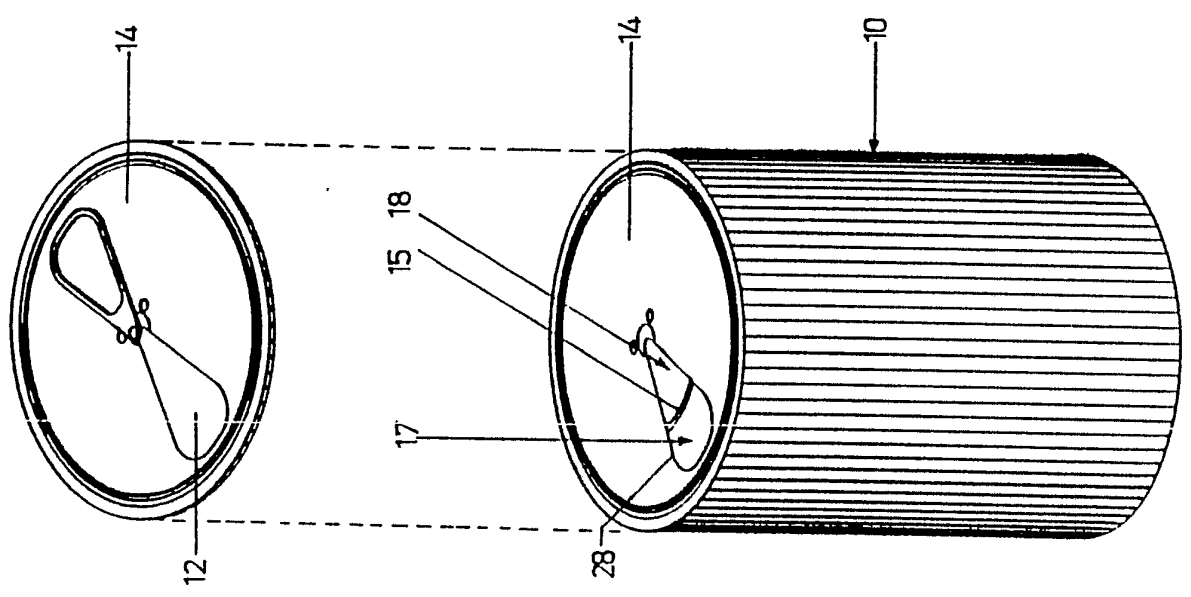

Fig. 1

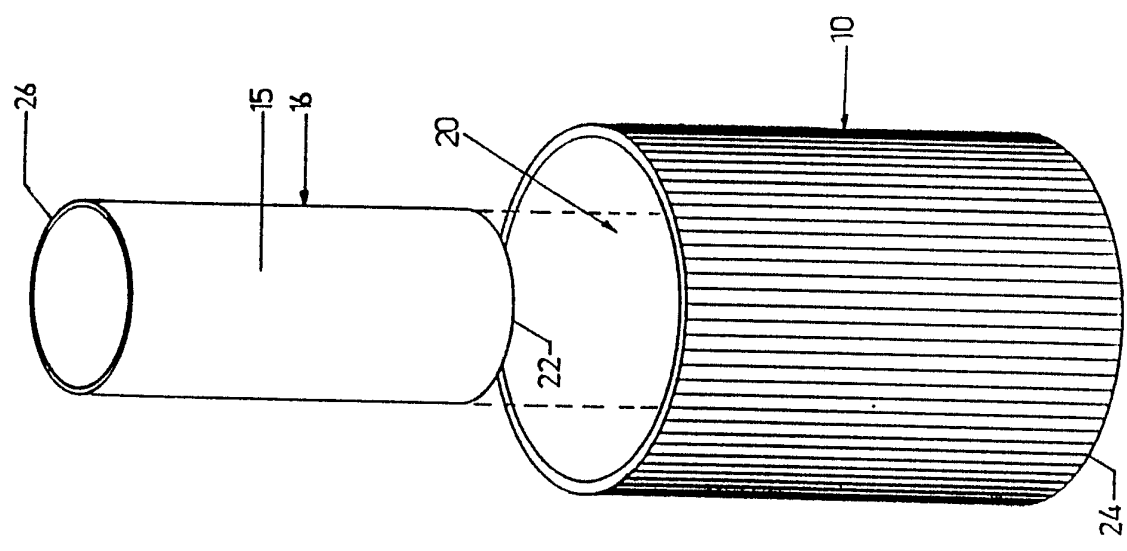

Fig. 2a

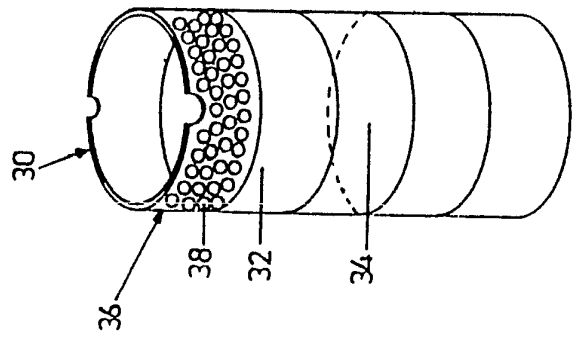

Fig. 2b

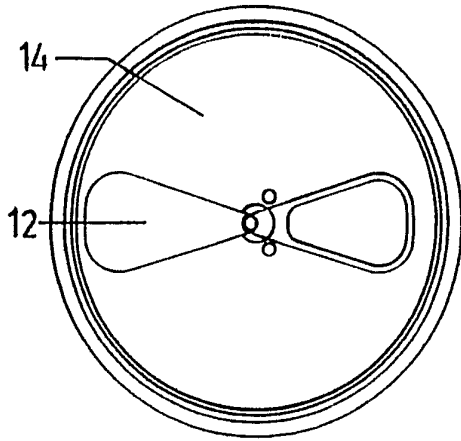

Fig. 3a

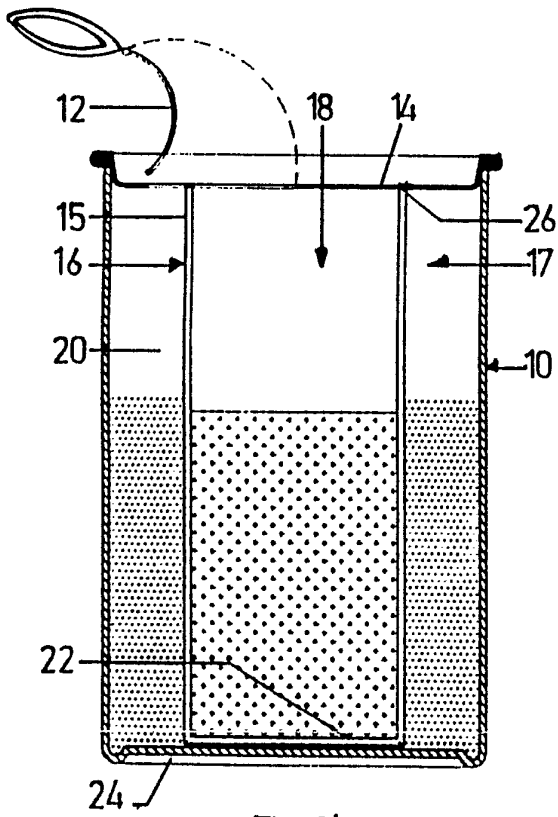

Fig. 3b

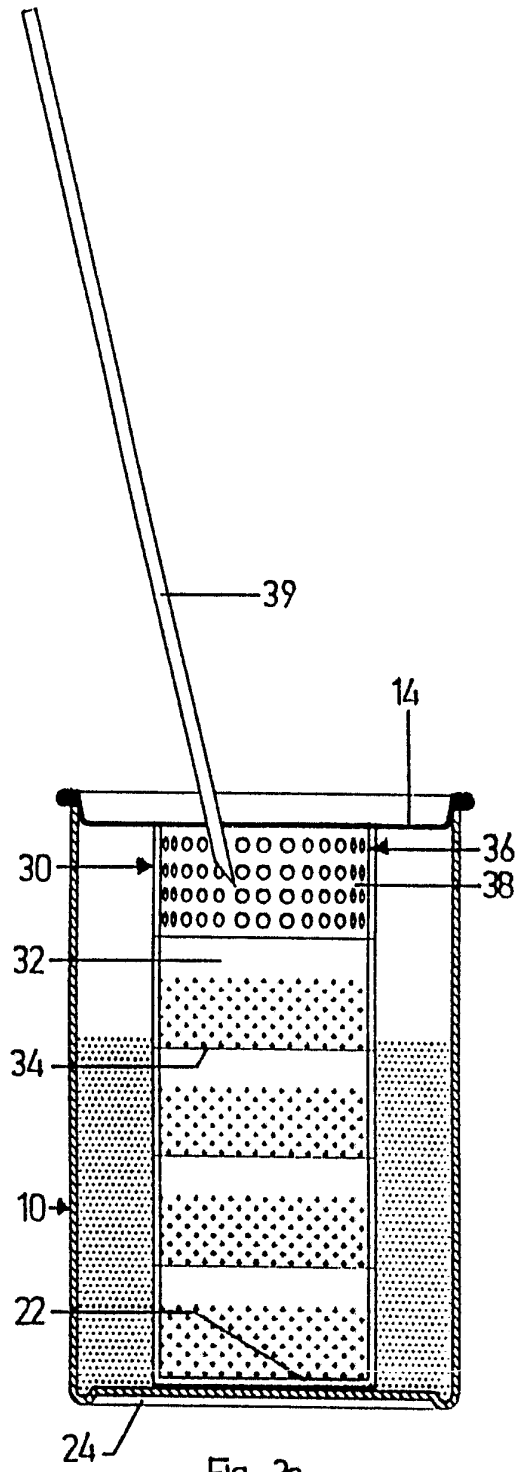

Fig. 3c

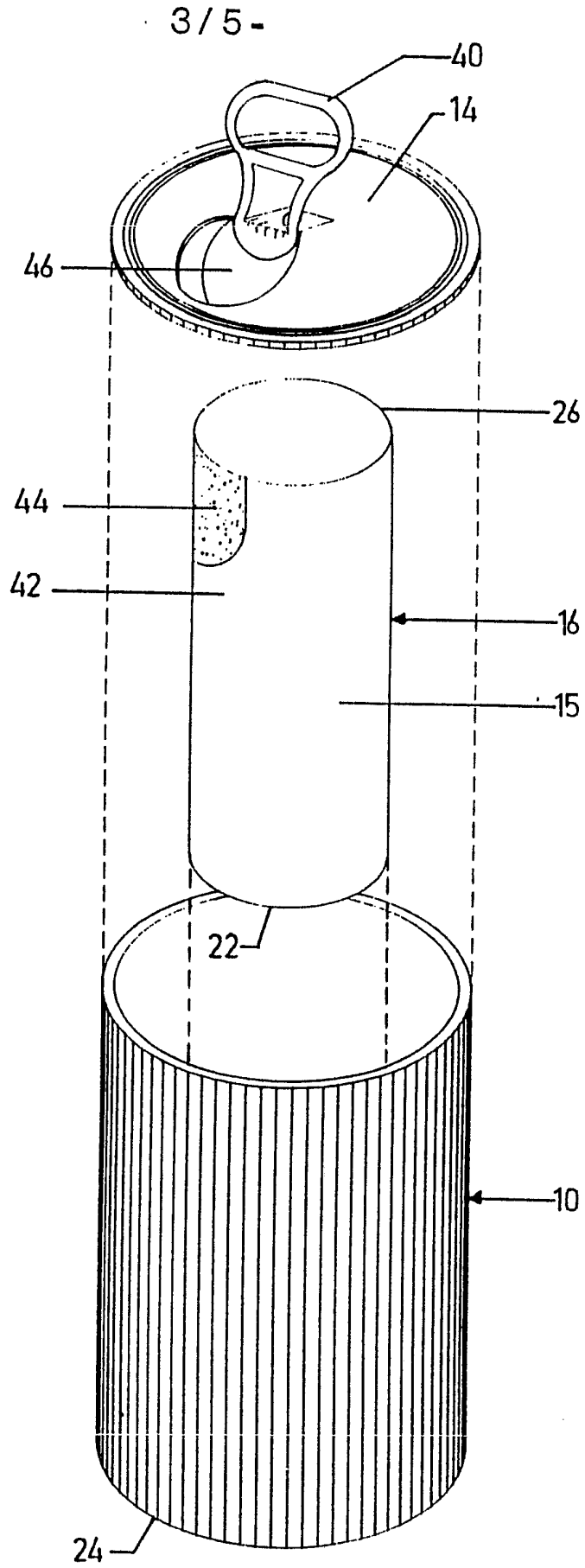

Fig. 4a

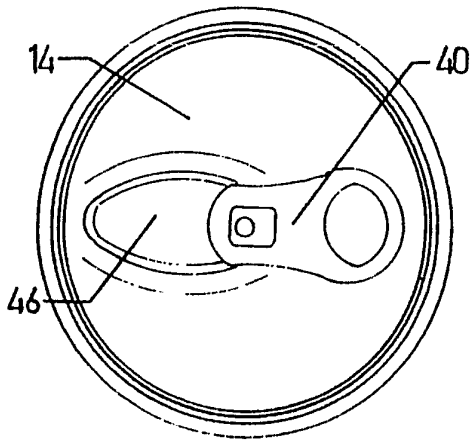

Fig. 4b

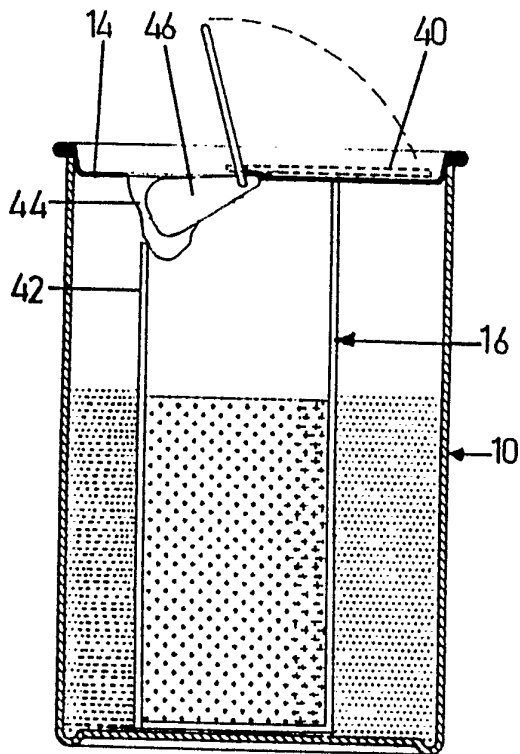

Fig. 4c

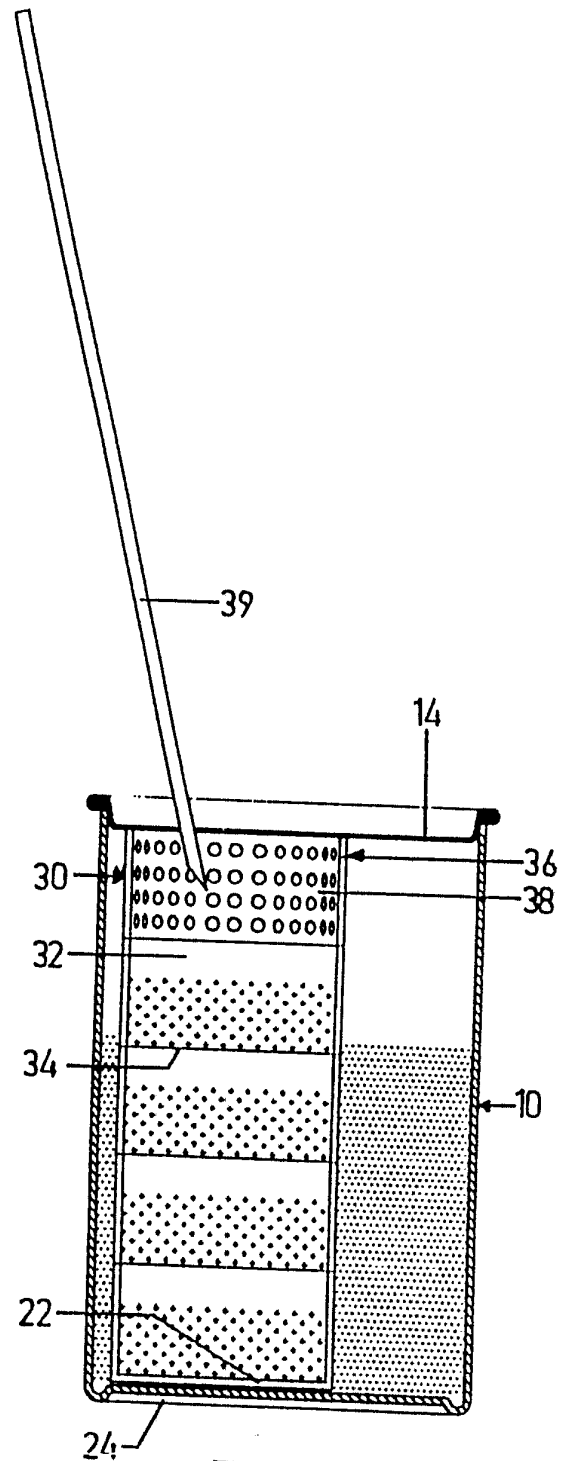

Fig. 4d

5 / 5 -

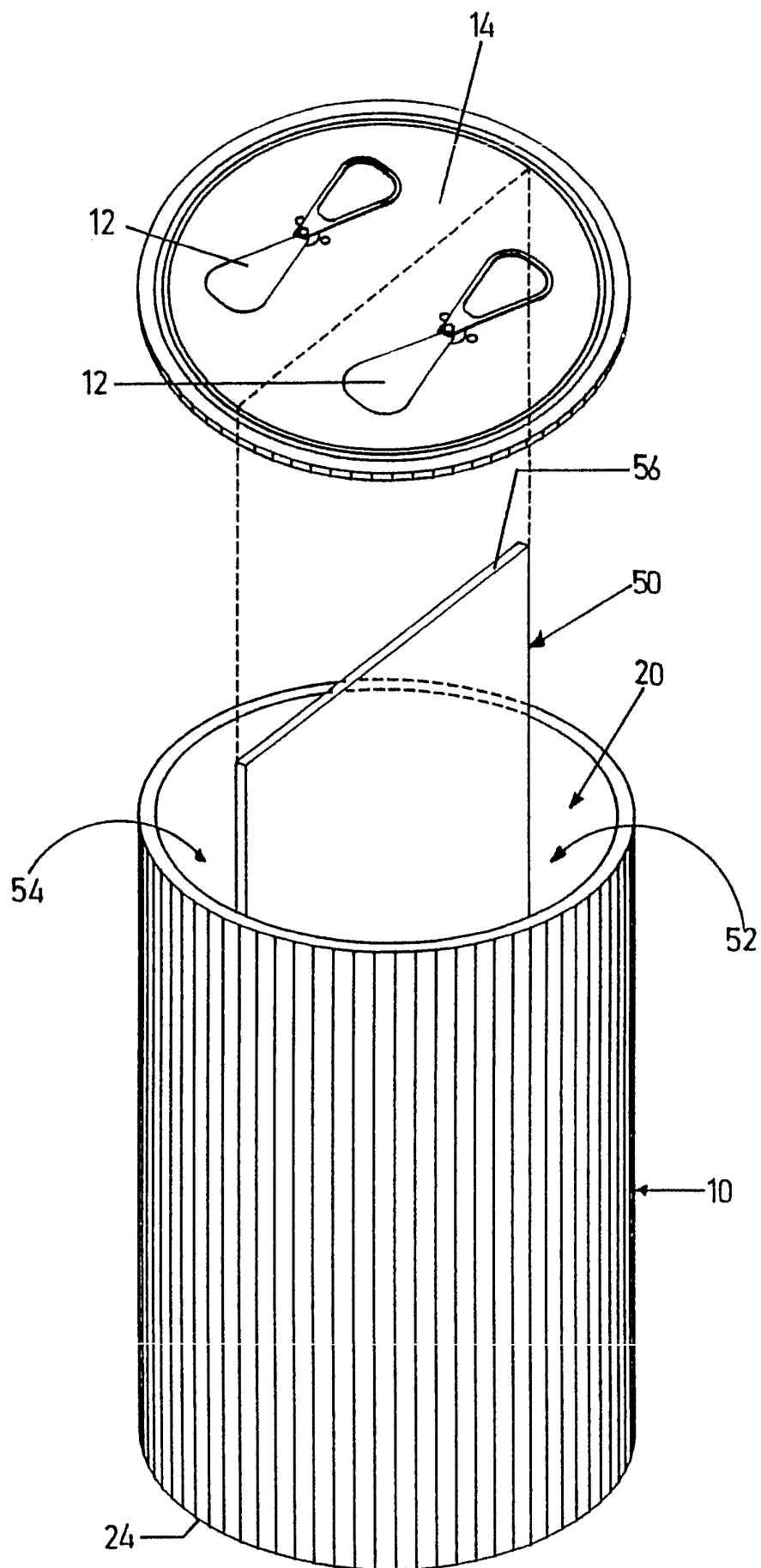
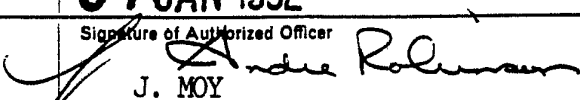

Fig. 5

INTERNATIONAL SEARCH REPORT

International Application No.

PCT/US91/07588

I. CLASSIFICATION OF SUBJECT MATTER (if several classification symbols apply, indicate all) ⁶				
According to International Patent Classification (IPC) or to both National Classification and IPC IPC(5): B65D 25/08				
ii. FIELDS SEARCHED				
Minimum Documentation Searched ⁷				
Classification System	Classification Symbols			
U.S.	206/219,221,222 220/506			
Documentation Searched other than Minimum Documentation to the Extent that such Documents are Included in the Fields Searched ⁸				
III. DOCUMENTS CONSIDERED TO BE RELEVANT ⁹				
Category [*]	Citation of Document, ¹¹ with indication, where appropriate, of the relevant passages ¹²	Relevant to Claim No. ¹³		
X	US, A, 3,305,368 (BOURELLE) 21 FEBRUARY 1967 See entire document.	1-18		
X	US, A, 3,741,383 (WITWER) 26 JUNE 1973 See entire document.	1-18		
A	US, A, 3,920,226 (WALT) 18 NOVEMBER 1975			
A	US, A, 4,353,463 (SEEMANN) 12 OCTOBER 1982			
A	US, A, 3,221,917 (De SANTO ET AL.) 07 DECEMBER 1965			
A	US, A, 4,632,244 (LANDAU) 30 DECEMBER 1986			
<table style="width: 100%; border: none;"> <tr> <td style="width: 50%; border: none; vertical-align: top;"> [*] Special categories of cited documents: ¹⁰ "A" document defining the general state of the art which is not considered to be of particular relevance "E" earlier document but published on or after the international filing date "L" document which may throw doubts on priority claim(s) or which is cited to establish the publication date of another citation or other special reason (as specified) "O" document referring to an oral disclosure, use, exhibition or other means "P" document published prior to the international filing date but later than the priority date claimed </td> <td style="width: 50%; border: none; vertical-align: top;"> "T" later document published after the international filing date or priority date and not in conflict with the application but cited to understand the principle or theory underlying the invention "X" document of particular relevance; the claimed invention cannot be considered novel or cannot be considered to involve an inventive step "Y" document of particular relevance; the claimed invention cannot be considered to involve an inventive step when the document is combined with one or more other such documents, such combination being obvious to a person skilled in the art. "&" document member of the same patent family </td> </tr> </table>			[*] Special categories of cited documents: ¹⁰ "A" document defining the general state of the art which is not considered to be of particular relevance "E" earlier document but published on or after the international filing date "L" document which may throw doubts on priority claim(s) or which is cited to establish the publication date of another citation or other special reason (as specified) "O" document referring to an oral disclosure, use, exhibition or other means "P" document published prior to the international filing date but later than the priority date claimed	"T" later document published after the international filing date or priority date and not in conflict with the application but cited to understand the principle or theory underlying the invention "X" document of particular relevance; the claimed invention cannot be considered novel or cannot be considered to involve an inventive step "Y" document of particular relevance; the claimed invention cannot be considered to involve an inventive step when the document is combined with one or more other such documents, such combination being obvious to a person skilled in the art. "&" document member of the same patent family
[*] Special categories of cited documents: ¹⁰ "A" document defining the general state of the art which is not considered to be of particular relevance "E" earlier document but published on or after the international filing date "L" document which may throw doubts on priority claim(s) or which is cited to establish the publication date of another citation or other special reason (as specified) "O" document referring to an oral disclosure, use, exhibition or other means "P" document published prior to the international filing date but later than the priority date claimed	"T" later document published after the international filing date or priority date and not in conflict with the application but cited to understand the principle or theory underlying the invention "X" document of particular relevance; the claimed invention cannot be considered novel or cannot be considered to involve an inventive step "Y" document of particular relevance; the claimed invention cannot be considered to involve an inventive step when the document is combined with one or more other such documents, such combination being obvious to a person skilled in the art. "&" document member of the same patent family			
IV. CERTIFICATION				
Date of the Actual Completion of the International Search	Date of Mailing of this International Search Report			
10 DECEMBER 1991	07 JAN 1992			
International Searching Authority	Signature of Authorized Officer			
ISA/US	 J. MOY			