

(No Model.)

8 Sheets—Sheet 1.

A. GOODYEAR.
HARVESTING MACHINE.

No. 381,232.

Patented Apr. 17, 1888.

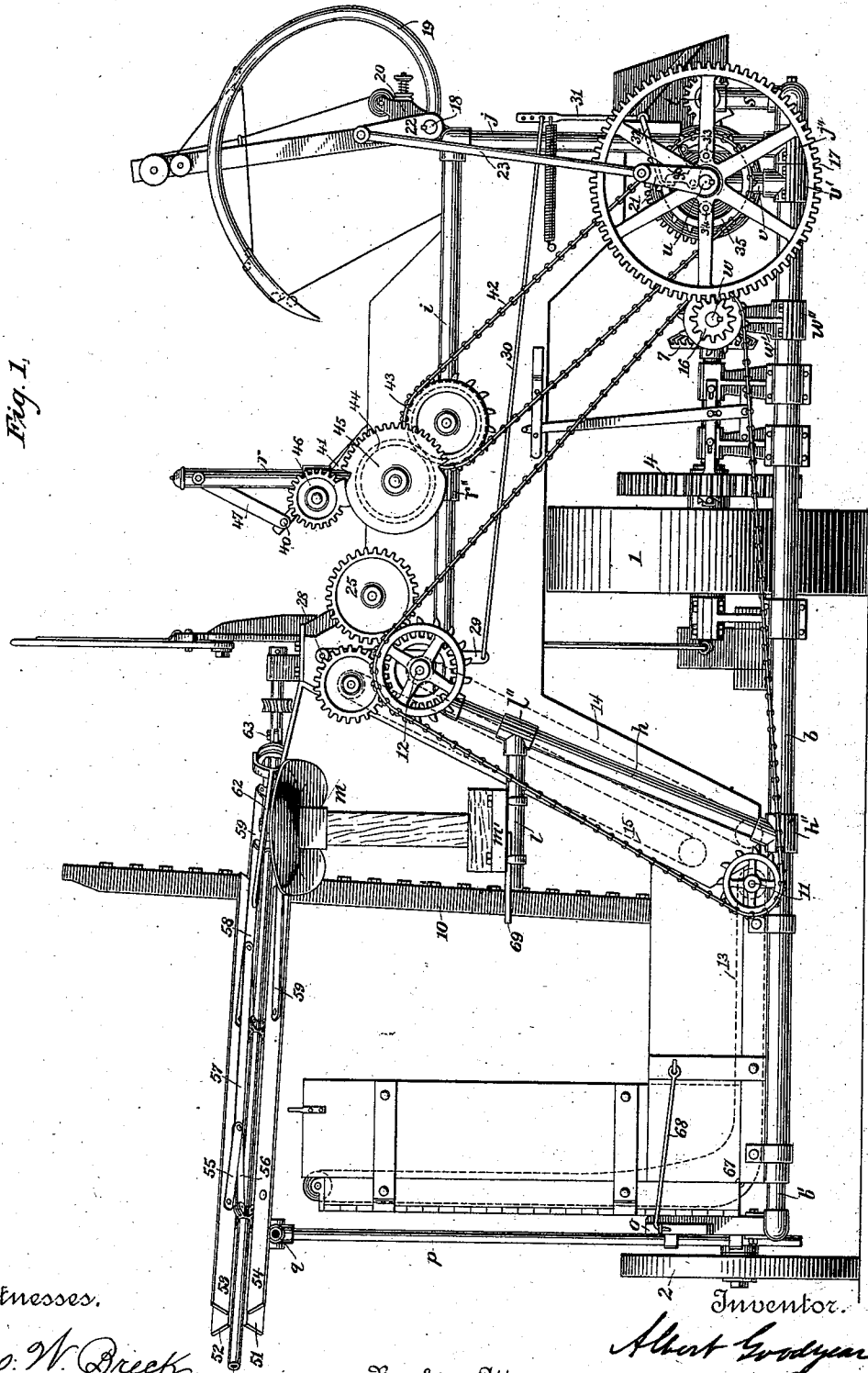

Fig. 1.

Witnesses.

Geo. W. Dreck.
Garric E. Ashley

By his Attorney

Inventor.
Albert Goodyear
Lufford & Brown.

(No Model.)

8 Sheets—Sheet 2.

A. GOODYEAR.
HARVESTING MACHINE.

No. 381,232.

Patented Apr. 17, 1888.

Fig. 2.

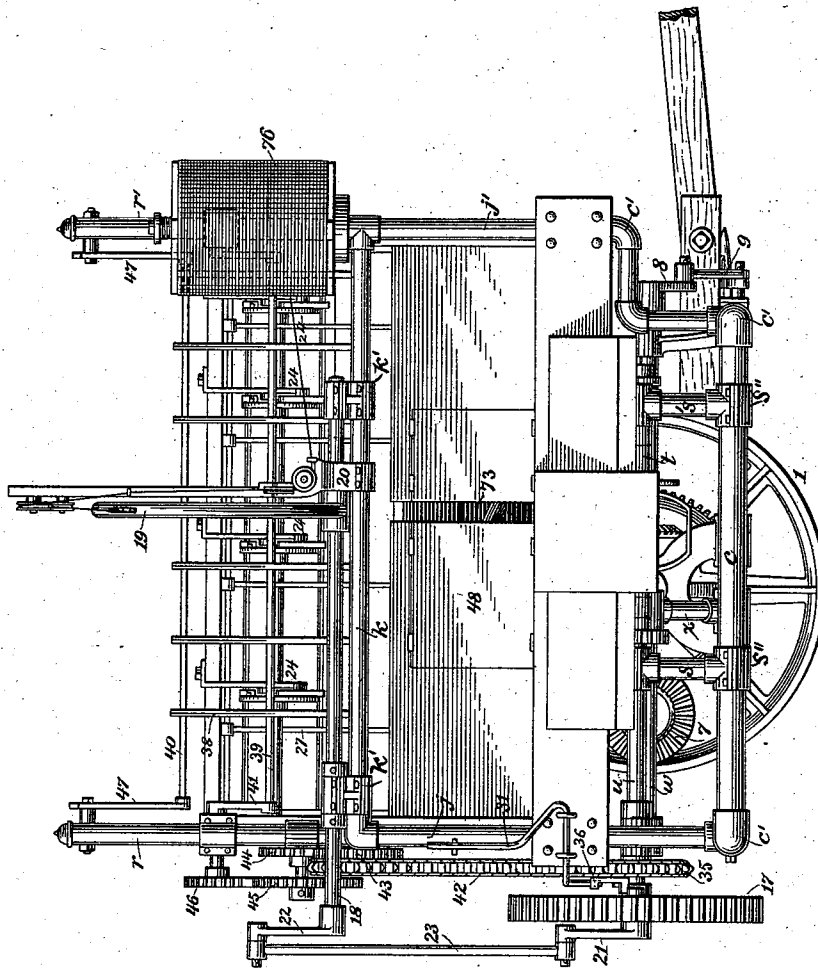

Witnesses.

Geo. W. Breck
Carrie E. Ashley

By his Attorney

Inventor.

Albert Goodyear
Lifford & Brown.

(No Model.)

8 Sheets—Sheet 3.

A. GOODYEAR.
HARVESTING MACHINE.

No. 381,232.

Patented Apr. 17, 1888.

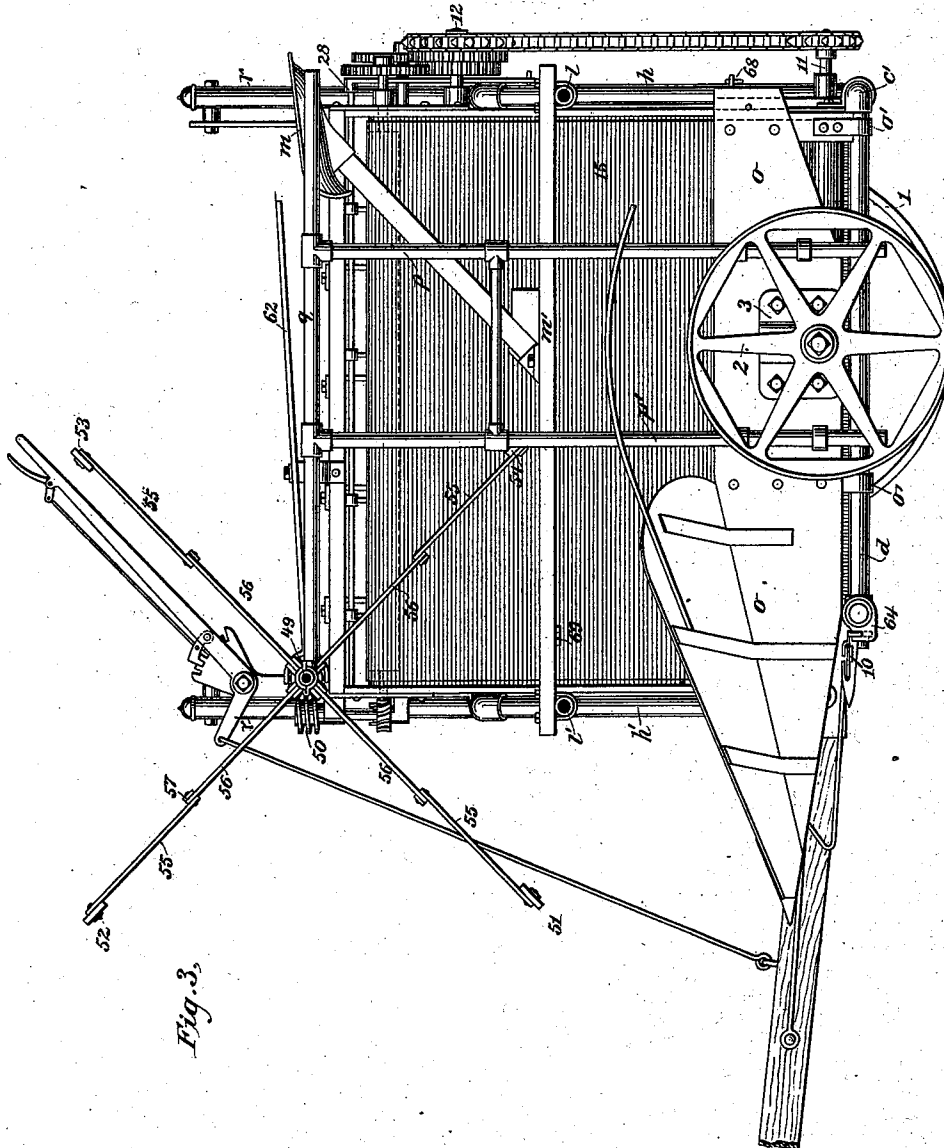

Fig. 3.

Witnesses.

Geo. W. Bruck.
Carrie C. Ashley

Inventor.

Albert Goodyear.
Lufford & Brown.

By his Attorney

(No Model.)

8 Sheets—Sheet 4.

A. GOODYEAR.
HARVESTING MACHINE.

No. 381,232.

Patented Apr. 17, 1888.

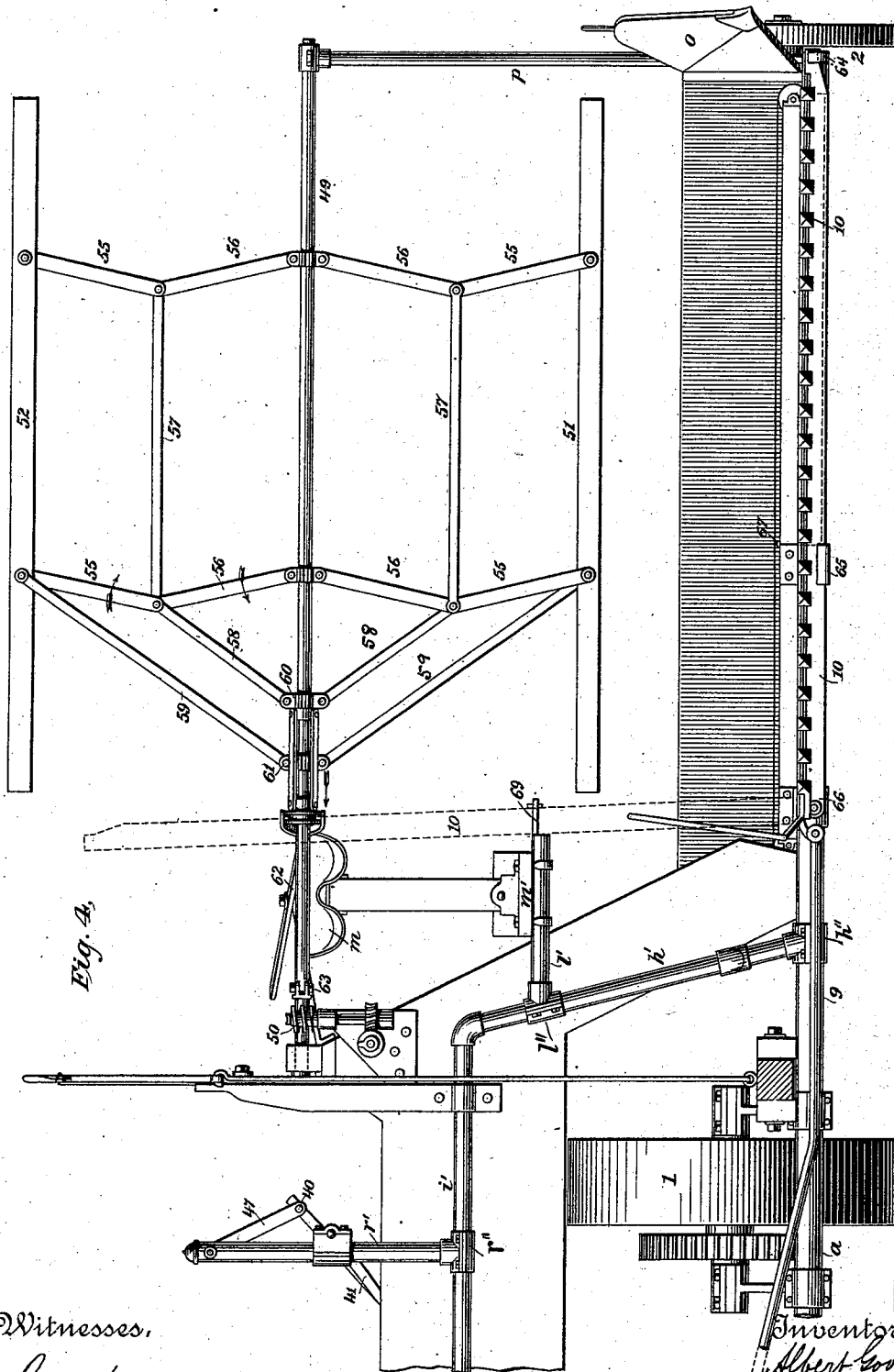

Fig. 4.

Witnesses,
 Geo. W. Breck
 Gamie C. Ashley

By his Attorney

Inventor
 Albert Goodyear
 Clifford & Brown

(No Model.)

8 Sheets—Sheet 5.

A. GOODYEAR. HARVESTING MACHINE.

No. 381,232.

Patented Apr. 17, 1888.

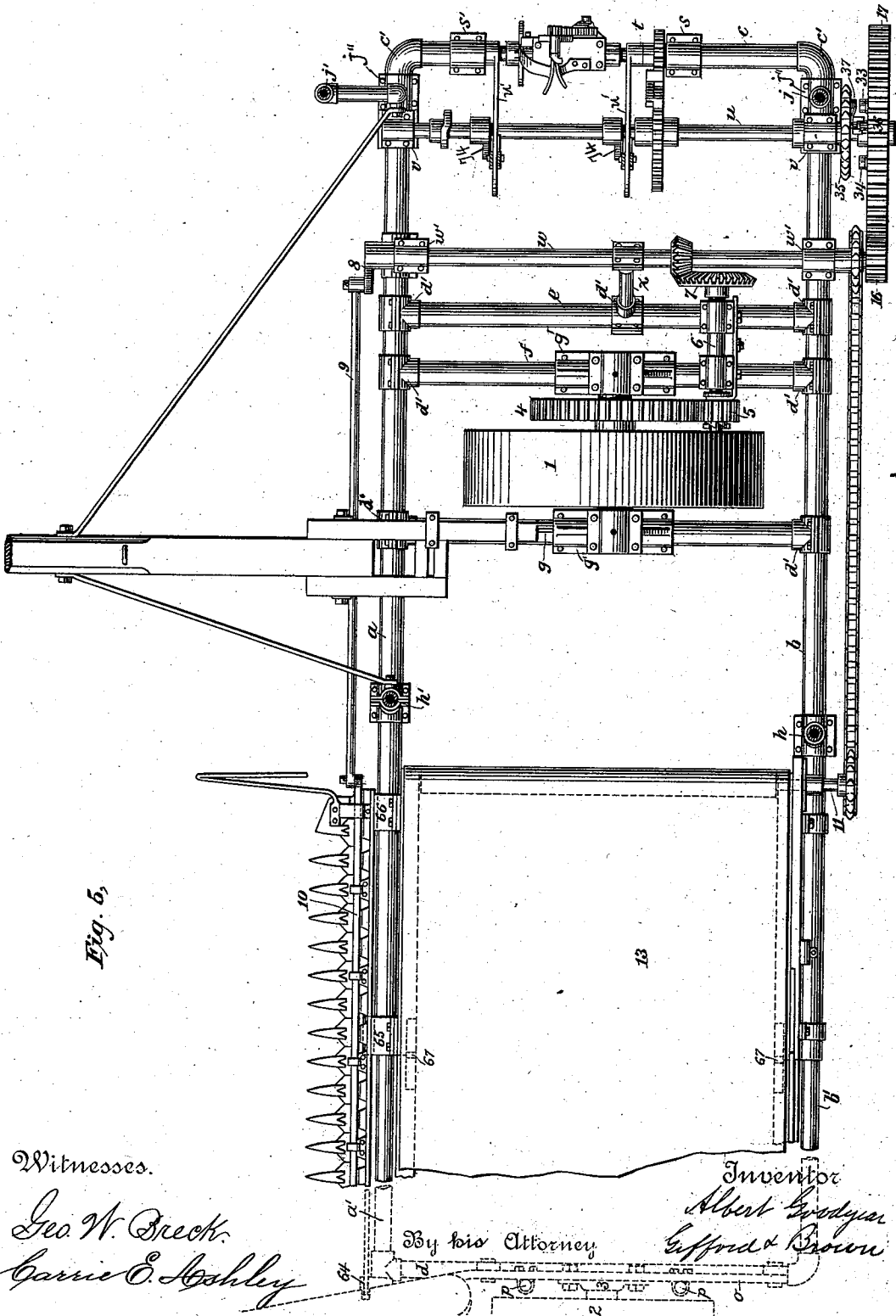

Fig. 6.

Witnesses.

Geo W. Brecht.

Garric C. Ashley

By his Attorney

Inventor
Albert Goodyear
Coffin & Brown

(No Model.)

8 Sheets—Sheet 6.

A. GOODYEAR.
HARVESTING MACHINE.

No. 381,232.

Patented Apr. 17, 1888.

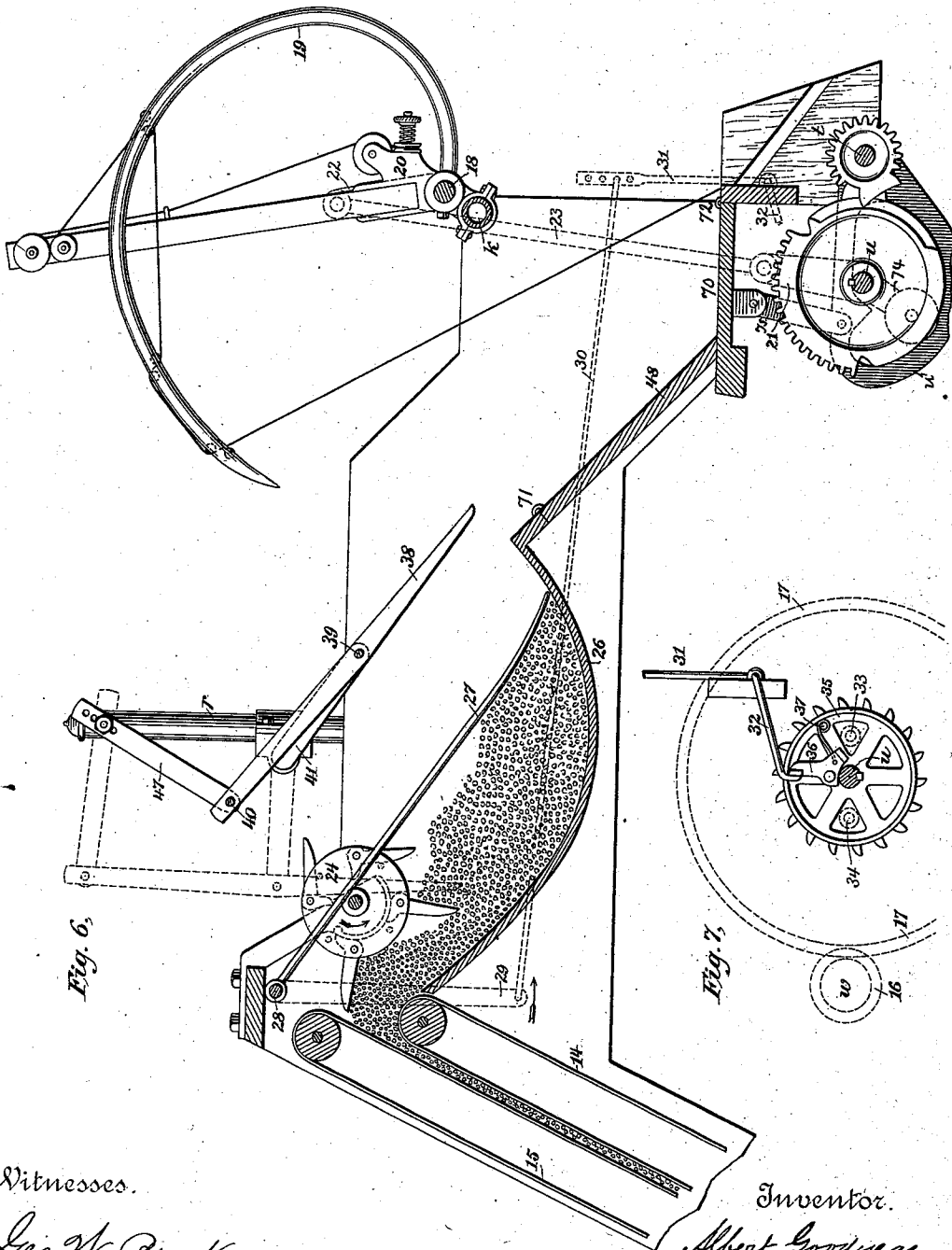

Fig. 6.

Fig. 7.

Witnesses.

Geo. W. Brock
Carrie E. Ashley

By his Attorney

Inventor.

Albert Goodyear.
Gifford & Brown

(No Model.)

8 Sheets—Sheet 8.

A. GOODYEAR.
HARVESTING MACHINE.

No. 381,232.

Patented Apr. 17, 1888.

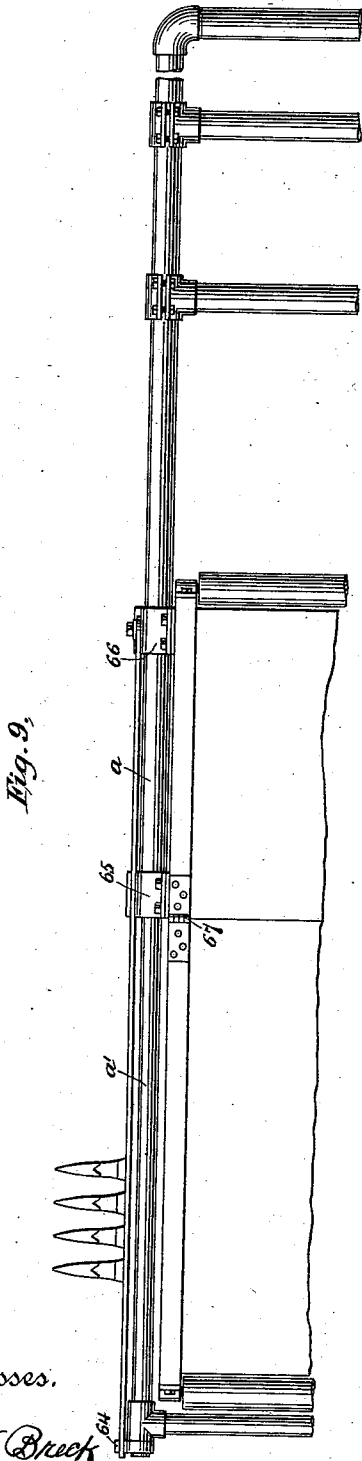

Fig. 11b,

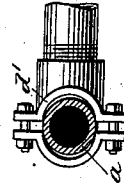

Fig. 13.

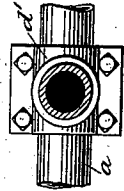

Fig. 12.

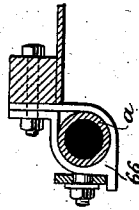

Fig. 14.

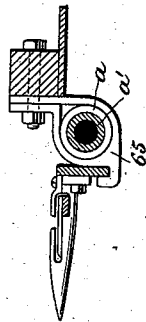

Fig. 10.

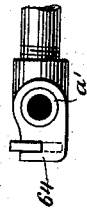
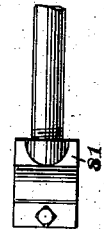

Fig. 15.



Fig. 16.



Witnesses.

Geo. W. Brock
Carrie C. Ashley

Inventor.

By his Attorneys

Albert Goodyear
Gifford & Brown.

UNITED STATES PATENT OFFICE.

ALBERT GOODYEAR, OF NEW HAVEN, CONNECTICUT.

HARVESTING-MACHINE.

SPECIFICATION forming part of Letters Patent No. 381,232, dated April 17, 1888.

Application filed August 2, 1886. Serial No. 209,719. (No model.)

To all whom it may concern:

Be it known that I, ALBERT GOODYEAR, a citizen of the United States, residing at New Haven, county of New Haven, and State of Connecticut, have invented a new and useful Improvement in Harvesting-Machines, of which the following is a specification.

The first part of my invention consists in mounting the various operative parts of the machine upon the main frame by means of clips which embrace the tubing of the frame and serve to secure the parts thereto and admit of adjustment of the various parts on the frame.

The second part of my invention consists in providing an accumulator intermediate the elevator and the grain-platform, and providing in connection with said accumulator a tripping device, which is so connected with the knotting mechanism as to start the latter in operation when tripped by the grain.

The third part of my invention consists in causing the folding platform to be started in operation by the tripper acting in connection with the accumulator.

Other features of the invention are specified in the claims.

In the drawings I have represented a machine embodying my invention and constructed in a form which I prefer for that purpose, though I do not desire to be understood as limiting myself to the form which I am about to describe, since I am aware that mechanics in carrying out my invention would probably introduce many variations in the form of apparatus.

Figure 1 is a rear view of the machine, showing the parts in a folded position. Fig. 2 is a side view taken from the side at which the grain is delivered. Fig. 3 is a view of the opposite side or the side on which the platform is located. Fig. 4 is a front view showing the parts in a position for operation. Fig. 5 is a sectional plan view showing the frame and shafting with the other parts removed. Fig. 6 is a detail sectional view showing the parts for handling the grain from the point where it is delivered by the aprons to its discharge from the machine. Fig. 7 shows in detail certain tripping mechanism. Fig. 8 is a diagram showing the position of needle and grain-platform when down. Fig. 9 is a plan view of the finger-bar and the brackets supporting the

same, showing also a portion of the hinged platform. Fig. 10 is a cross-section of the bracket supporting the finger-bar on its free end. Fig. 11 is a cross-section of one of the brackets supporting the finger-bar intermediate its two ends; and Fig. 12 is a cross-section of the end bracket to which the finger-bar is pivoted, showing the manner of pivoting the finger-bar thereto. Figs. 13 and 14 are respectively a plan view and cross-section of one of the clips which are used throughout my machine to make adjustable connections between the parts. Figs. 15 and 16 are respectively a side and plan view of the bearing for the reel-shaft on its free end.

I will first describe the construction of the frame. It is made up of tubes or piping. The main frame of the machine consists of pipes extending along the front and along the rear and across both ends of the machine underneath. The front and rear pipes just referred to are each made up of two sections, *a a'* *b b'*. The sections *a' b'* are enough smaller in diameter than the section *a* and *b* to fit snugly within the latter, so as to form a telescopic joint therewith.

c is the pipe which connects the two pipes *a* and *b* at one end of the machine, and *d* is the pipe which connects the two pipes *a' b'* at the other end of the machine. The main frame of the machine is thus made in the form of a parallelogram, which, by the telescopic joint already referred to, may be lengthened or shortened, as required. Where two lengths of pipe are to be joined together at their ends I employ the ordinary couplings, such as are shown at *c'*; but where two lengths of pipe are to be joined, so that the end of one is secured to the side of another, I employ clips—such as are shown at *d'*—which consist of a socket into which the end of one of the pipes is screwed and a collar made in two halves and provided with bolts, as shown most clearly in Figs. 13 and 14, so that it may be placed upon the other pipe in any position desired and secured firmly upon its exterior, thus forming substantially a clip-joint, which is adapted to be moved to any part of the pipe to the side of which it is attached.

e, *f*, and *g* are pipes extending across from the pipe *a* to the pipe *b*.

From the frame already described the front

and rear side frames rise, composed of the pipes *h i j k' i' j'*. The pipe *k* connects the pipes *j* and *j'* together at their tops. The pipes *l* and *l'* project horizontally from the pipes *h k'*, to which they are secured by clips *l''*, in proper position to support the seat *m* and foot-rest *m'*, as shown.

o is the board divider, which is secured to straps clipped fast to the pipe *d* at *o'*.

p p' are upright pipes, which may be secured to the divider, as is shown in Fig. 3. On top of these two pipes is mounted a cross-pipe, *q*, on the forward extremity of which is formed the bearings for one end of the reel.

r r' are upright pipes projecting upward from the pipes *i i'*, for the purpose of supporting certain mechanism, hereinafter more fully described.

s s' are pipes projecting upward from the pipe *c*, and are provided at their upper ends with the bearing for the shaft *t* of the knotting mechanism. The shaft *u* has its bearings at each end at the tops of pipes extending upward from the pipes *a* and *b*, respectively, one of which upright pipes is lettered *v*, Fig. 1.

w is a shaft extending from the front to rear of the machine, and which has bearings in supports from the pipes *a* and *b*, one of which is lettered *w'*, Fig. 1, and also has a support from the pipe *e* by the pipe *x*, as shown in Fig. 5.

Having described the parts of the frame and accessories, I will next proceed to describe the principal operative parts of the machine.

1 is the ground-wheel, which is mounted upon a shaft having its bearings secured to the pipes *f* and *g*, as shown.

2 is the grain-wheel. The axle of this wheel is secured at its inner end to a plate, 3, by a slotted connection, so as to be vertically adjustable. This plate 3 is suitably secured to the divider-board *o* and the pipe *d*.

Upon the shaft of the ground-wheel is mounted the spur-wheel 4, which gears with the pinion 5, and thus drives the shaft 6, on which is mounted the bevel-gear 7. This bevel-gear in turn drives the shaft *w*. Upon one end of this shaft *w* is mounted the crank 8, which, by the pitman-rod 9, communicates a reciprocating motion to the cutter or sickle bar 10. From the opposite end of the shaft *w* are driven by chain and sprocket wheels the shafts 11 and 12, which carry the rollers that drive the grain-belts 13 and 14. The roller for driving the grain-belt 15 is actuated by a pair of spur-gears from the shaft 12, as shown in Fig. 1. On the shaft *w* is also mounted the spur-gear 16, which meshes with and drives the spur-gear 17. The shaft 18 is mounted in bearings secured to the pipe *K*. Upon this shaft is secured the needle 19, which is employed in binding.

20 is a tension apparatus, which is also mounted upon the pipe *K*. The shaft 18 is given a rocking motion by means of the cranks 21 and 22 and connecting-rod 23. Crank 21 is mounted on end of shaft *u*.

24 is a feeding device, which is driven from

the shaft 12 by the spur-wheel 25. This feeding device is of the usual form heretofore in use, and consists, preferably, of two or more disks having teeth mounted on each, one of which is shown in Fig. 6. This feeding device is located in the position shown in Fig. 6, so that in revolving its teeth catch the grain as soon as it is discharged by the elevating-aprons, and immediately force it forward upon the accumulator 26, so that the elevating-aprons are prevented from being clogged or getting the straw out of position.

27 is a tripper which is pivoted at 28, and extends from that point downward and forward until it rests upon the accumulator 26. This tripper 27 is composed of a number of strips, and is not continuous. Its function is to remain in contact with the accumulator until sufficient grain is accumulated under it to make a bundle, but to be tripped upward as soon as sufficient has accumulated there for a bundle, so as to throw other mechanism into operation for securing the bundle. As the grain is forced forward by the feeding device 24, it will ultimately fill up the space below the tripper 27, and force that tripper upward, the result of doing which will be to force the lever 29 in the direction of the arrow, Fig. 6, which motion is communicated through the rod 30 to the lever 31, which in turn moves the tripping-pawl 32. The object of this tripping mechanism is to provide for so connecting and disconnecting the spur-wheel 17 with the shaft *u* that the shaft will only be rotated under the wheel when the grain has accumulated under the tripper 27 sufficiently to form a bundle. The connection of this tripping mechanism with the wheel 17 is most clearly shown in Fig. 7.

33 and 34 are short studs projecting from the inner face of the spur-wheel 17. The sprocket-wheel 35 is keyed to the shaft *u*, and upon its face is mounted the dog 36, of the form shown in Fig. 7. When this dog is in engagement with the pawl 32, it will be held in the position shown in Fig. 7, so that it will not engage with the studs 33 and 34; but whenever the pawl 32 is tripped, so as to release the dog, the pressure of the spring 37 will turn the dog sufficiently on its pivot to bring a projection on its tail into the path of the studs 33 and 34, so that the first stud that comes along will strike against the projection on the tail of the dog and carry the sprocket-wheel, and consequently the shaft *u*, around with the spur-wheel 17 until the dog again engages with the pawl 32, when it will be returned to the position shown in Fig. 7, and the connection between the spur-wheel 17 and the shaft *u* be broken. Thus it will be seen that whenever the tripper 27 is raised by the accumulation of grain beneath it the mechanism described will permit the sprocket-wheel 35 and the shaft *u* to be turned until the accumulation of grain is removed from under the tripper 27, so as to allow it to return to the position shown in Fig. 6. While, however, the sprocket-wheel 35 and

the shaft *u* are in operation they actuate two sets of mechanism, one of which removes a bundle of the grain from the accumulator 26 and the other of which binds it.

The mechanism which removes the grain from the concave 26 may be described as follows:

38 is a vibrating arm or divider, of which there are several, arranged in a series across the machine. These arms are pivoted at two points, 39 and 40. At 39 they are pivoted to a rod mounted on the extremity of the crank 41, and extending from that crank to a corresponding one on the other side of the machine. This crank 41 is driven from the sprocket-wheel 35 through the chain 42, the spur-wheels 43 44, and the segment-gears 45 and 46.

As it is necessary that the operation of the separators 38 shall be quickly performed, and not performed until the needle 19 has nearly finished its upward travel after having bound a bundle of grain, and that the separators shall be idle during the greater part of the time the needle is traveling, I provide the gear 45 with a mutilated surface, the plain portion of which will be engaged with a plain projection on the gear 46 during the first part of the revolution of 45, and consequently gear 46 and separators 38 will be locked and prevented from moving; but when the toothed portion of gear 45 comes into engagement with the teeth on gear 46 the former will be revolved through a complete revolution while the latter is going through a partial revolution. The vibrating arms or dividers 38 are pivoted to a rod, 40, secured to the extremities of the rocking levers 47. With the vibrating divider 38 sustained, as described, each rotation of the crank 41 causes it to move from the position shown in Fig. 6 in full lines to the position shown in dotted lines, and thence forward again to the position shown in full lines, where it is held for a time by the locking actions of gears 45 and 46, before referred to. This forward movement, however, carries with it sufficient of the grain from under the tripper 27 to form a bundle, which grain is thrown forward and rests against the inclined folding platform 48 and 70 in proper position to be bound. The folding platform 48 70 performs a double function. It presses the grain into the loop of the cord as it is being bound, and as soon as bound it serves to throw the bundle out of the machine. The platform is made up of the two folding sections 48 and 70, hinged so as to open upwardly, respectively, at 71 and 72. The section 48 overlaps the section 70, as shown in Fig. 6, so that the act of raising 70 raises 48 also.

Mechanism hereinafter fully described is provided, so that while the needle is in the elevated position shown in Fig. 6 the carriers are in the position shown in Fig. 6; but as soon as a bundle of grain has been thrown on the platform and the needle has commenced to descend to bind it the doors are thrown upward, as shown in Fig. 8.

Now, it will be seen that as soon as the nee-

dle descends the grain is inclosed by the loop of the cord and the section 70, and that the opening of the door acts to compress the bundle of grain between the door and the cord, so that the grain is pressed very tightly into the loop of cord, and the cord is secured by suitable twisting mechanism, while thus tightly compressing the grain. As soon as the cord is secured and cut loose, there will be nothing to hold the bundle to the platform, Fig. 8, and it will fall off onto the ground.

73, Fig. 2, is the slot which is cut through the platform, made to allow the point of the needle and twine to pass through and below it.

The described motions are given to the platform by the following mechanism:

u' is a lever, of which there are two, pivoted to the shaft *t* and encircling the shaft *u*, which passes through an opening cut through the lever. A lever, 74, of which there are two, (shown in dotted lines in Fig. 6,) is fixed to the shaft *u*, and is provided with a roller acting on the interior of the opening in lever *u'*, on a cam surface. The rod 75 conveys the motions of lever *u'* to the platform-section 70. The cam surface on lever *u'* is so formed, and the arm 74 is so set with reference to the crank 21, that while the needle is descending, brought down by the action of the crank 21, the platform will be rising.

The several parts already described are so timed that when the tripper 27 is tripped by the accumulation of grain beneath it the needle will immediately descend. When the needle has descended about half-way, the platform 70 rises and continues in its raised position till the needle has completed its descent and raised about half-way again, when it will fall. The arm 38 will remain stationary till the needle has been down and advanced considerably on its upward stroke. Then the arm 38 will quickly go through the motions heretofore described, so that by the time the needle has reached the top of its stroke a new bundle of grain will have been deposited on the platform, ready to be bound, as soon as the tripper 27 is again tripped, so as to start the shaft *u* into operation again.

76 is the twine-reel, and the course of the twine from this point through the needle to the binding mechanism is shown in Figs. 1, 2, and 6.

The mechanism for uniting the ends of the binding-cord may be of any suitable form for accomplishing that result, though I prefer to employ the mechanism described in my application for patent filed of even date herewith, and certain parts are shown in the drawings on the shaft *t*, adapted for that form of mechanism.

I will next describe the construction of my folding reel.

In Figs. 3 and 4 it is shown opened. In Fig. 1 it is shown closed. 49 is the shaft upon which it turns, which has its bearings at one end on the pipe *q* and at the other end in a proper support from the main frame.

I have shown the bearing of the reel-shaft on the pipe *g* as a U-shaped socket, 81, unadjustable on the said pipe. At Figs. 15 and 16 this bearing is shown most clearly, where it will be seen that a cap-plate, 82, is provided to secure the reel in place while in operation. This shaft is turned by means of the worm-gear 50, which is driven from the operative parts of the machine by any suitable connections.

51, 52, 53, and 54 are the strips which strike the grain. Each of them is connected with the collar on the shaft by the jointed arms 55 and 56.

57 are rods connecting every two pair of rods, 55 and 56, at their junction. 58 connects the end of 57 with a sliding sleeve on the shaft, there being one, 58, for each 57. 59, of which there are four, connects 51, 52, 53, and 54 with the sliding sleeve 61 on the shaft.

The relative dimensions of the parts are substantially as shown. The sleeves 61 and 60 are connected, as shown in Fig. 4, with a lever, 62, which is used in closing the reel. This closing is accomplished by moving the collars in the direction of the arrow, which will cause the rods 55 and 56 to move, respectively, in the direction of the arrows crossing them. The reel may thus be closed, as shown in Fig. 1. The same means may obviously be employed to adjust the strips 51 52 53 54, so as to strike the grain at varying heights from the cutters, using the reel partly or wholly open. At 63 is a joint in the shaft 49, which enables the shaft, when the reel is folded, to be swung around, so as not to project beyond the platform, as shown in Fig. 1, where the folded reel will be seen to rest simply on the pipe *g*, along which it may be moved to locate it in a position best adapted to economize space.

I will now describe the provision for folding the platform and cutting device.

64 is a bracket clipped to the pipe *a'* at its extremity, and which is provided with a slot opening upward to receive the extremity of the finger-bar, as shown in Figs. 3 and 4 and at Figs. 9 and 10.

65 and 66 are respectively brackets of a similar character, which also support the bar. At 66 the finger-bar is pivoted, as shown most clearly at Figs. 9 and 12. Thus, when in position to operate, the finger-bar rests in the three brackets; but it may be turned upward into the position shown in Fig. 1 and in dotted lines in Fig. 4, carrying with it the cutter or sickle bar, which is joined to the reciprocating rod 9 by a hinged connection for that purpose.

The grain-platform is hinged at 67, so that by separating it from the divider *o* its outer portion may be folded from the position of Fig. 4 into the position of Fig. 1. As soon as the bar and platform have been folded, as described, the pipe-sections *a' b'* may be pushed into the sections *a* and *b* until the wheel 2 and divider *o* occupy the position shown in Fig. 1, where they may be secured by the hook 68.

When in this condition, the machine is in comparatively small compass and is convenient to transport.

69 is a catch secured to the seat-support, by which the finger-bar may be held in its raised position.

A feature of great utility in my machine is the provision which is made by the clips, already referred to, for the adjustment of all its parts. All of the clips used for purposes of adjustment in my machine are substantially like that one shown in detail in Figs. 13 and 14. The side frames may be adjusted on the bed of the frame by means of the clips *h'' j''*, Fig. 1. The seat may be adjusted on the tubing *h k* by means of the clips, as *l''*, Fig. 1. The uprights *r r'* are adjustable on *i i'* by means of clips, as *r''*, Fig. 4. The pieces of tubing *e f g* are adjustable on the main frame by means of clips, as *d'*, Fig. 5. The uprights sustaining the bearings of the ground-wheel are adjustable on the tubing *f g* by means of clips, as *g' g'*, Fig. 5. The shaft *w* is adjustable on the frame by having its uprights connected with the frame by clips, as *w''*, Fig. 1. The uprights *v*, sustaining the bearings of the shaft *u*, are adjustable on the frame by clips, as *v'*, Fig. 1. The uprights *S S'* are adjustable on the tube *c* by means of the clips *s''*, Fig. 2. The bearings of the shaft 18 are adjustable on the tube *k* by means of the clips *k'*, Fig. 2.

The uprights sustaining the bearings of the shaft 6 are likewise connected with the tubes *e f* by adjustable clips. The brackets 64 65 66 are likewise adjustable on the frame by being connected therewith by clips, as shown. The connecting-piece *x* is likewise connected with the tube *c* by an adjustable clip, *d'*, Fig. 5.

Although I have shown in the drawings and described in this application my features of the pivotal and expansible reel and extensible platform, a pivoted cutter-bar, and a hinged grain-platform and their combinations with one another and the remainder of the machine, I have not claimed those features herein, withdrawing and reserving the same to be claimed in another application filed in the Patent Office on the 5th day of March, Serial No. 266,120, executed on the 24th day of February, 1888.

What I claim as my invention, and desire to secure by Letters Patent, is—

1. In combination with the front and rear tubing, *a* and *b*, of the bed, the side frames composed of tubing, substantially as described, and the clips uniting the side frames with the bed, substantially as described, whereby the side frames are adjustable on the bed, as set forth.

2. In the bed-frame of a harvesting-machine, in combination, the front and rear tubing, *a* and *b*, the tubing *a'* and *b'*, forming a telescope or sliding joint with the former, and the cross-tubing *c* and *d*, substantially as described.

3. In combination with the side frames, the seat-supporting tubing *l l'*, mounted thereon, and the clips whereby the said tubing is ad-

justably secured to said frames, substantially as described.

4. In combination with the tubing *a*, *b*, and *c* and the uprights *j* *j'*, the cross-piece *k*, the binding-needle shaft mounted thereon, and the clips whereby the bearings of said shaft are adjustably secured to said piece *k*, substantially as described.

5. In combination with the side frames, composed of the upright tubing *h* *h'* and *j* *j'*, *h* and *j* connected by the cross-tube *i* and *h'* and *j'* by the cross-tube *i'*, the uprights *r* *r'*, mounted on the tubing *i* *i'*, and clips whereby the uprights are adjustably secured to the tubing, substantially as described.

6. In combination with the tubing *a*, *b*, and *c*, the uprights *s* *s'*, the clips adjustably securing said uprights to the tube *c*, and the knotting-mechanism shaft *t*, having its bearings on said uprights, substantially as described.

7. In combination with the tubing *a* and *b* and the shaft *u*, the uprights on which are mounted the bearings of said shaft, and the clips whereby said uprights are adjustably secured to said tubing.

8. In combination with the tubing *a* and *b*, the shaft *w*, having its bearings on uprights, and the clips whereby said uprights are adjustably secured to said tubing, substantially as specified.

9. In combination with the tubing *a* and *b*, the cross-piece *e*, and the clips whereby said cross-piece is adjustably secured to said tubing, substantially as described.

10. In combination with the tubing *a* and *b* and the ground-wheel, the cross-pieces *f* and *g*, with which the ground-wheel is connected, and the clips whereby said cross-pieces are adjustably secured to said tubing, substantially as described.

11. In combination with the frame of the machine, the cross-tubing *f* and *g*, the ground-wheel having its bearings in uprights on said

tubing, and the clips whereby said uprights are adjustably secured to said cross-tubing, substantially as described.

12. In combination with the frame of the machine, the cross-tubing *e* and *f*, the shaft *6*, having its bearings on said tubing, and the clips whereby said bearings are adjustably secured to said tubing, substantially as described.

13. In combination with the grain-elevator and the folding binding-platform, an intermediate grain-receptacle upon which the grain is delivered, and mechanism, substantially as described, whereby the divider is actuated by the tripping of the tripper to throw the bundle of grain onto the folding binding platform, substantially as described.

14. In combination, the tripper *27*, the grain-receptacle *26*, the folding binding-platform, the needle, and mechanism whereby the tripping of the tripper causes the platform to rise and the needle to descend simultaneously, thereby compressing the bundle, substantially as described.

15. In combination, the grain-receptacle *26*, the tripper *27*, the divider, the folding binding-platform, the binding-needle, and mechanism, substantially as described, whereby the divider is actuated by the tripping of the tripper to throw a bundle of grain onto the platform in its normal position, and whereby said platform is raised as the needle descends, thereby compressing the grain; substantially as described.

16. In combination, the rising and falling binding-platform, the hopper, and the tripper whereby the binding-platform is set in operation by the accumulation of grain in the hopper, substantially as described.

ALBERT GOODYEAR.

Witnesses:

LIVINGSTON GIFFORD,
CHAS. T. WARD.