

54] OCCUPANT PROPELLED ROUNDABOUT

76] Inventor: Joseph L. Parsons, Star-Rt. 1, Box 81 A, Union, Wash. 98592

22] Filed: Mar. 6, 1974

21] Appl. No.: 448,740

52] U.S. Cl. 272/33 B

51] Int. Cl. A63g 1/12

58] Field of Search 272/57 A, 33 R, 33 A, 33 B, 272/43, 46, 47, 48, 34, 35, 29, 28 R, 28 S, 73; 248/349; 108/94; 312/252; 104/35, 36, 37, 38, 39, 40, 41, 42, 43, 44, 45, 46, 47, 68, 75

56] References Cited

UNITED STATES PATENTS

592,569	10/1897	Lehmann	272/33 R
671,058	4/1901	Resetar	272/33 R
727,778	5/1903	Friedman	272/33 R
325,374	12/1919	Pilushczak	272/33 R
457,035	5/1923	Kotlik	272/43
529,512	3/1925	Smerechanski	272/33 R
484,732	10/1949	Ragsdale	272/33 R
515,499	7/1950	Drucker	272/33 R
677,541	7/1972	Race	272/33 R

FOREIGN PATENTS OR APPLICATIONS

39,794	1/1923	Norway	272/33 R
80,824	6/1894	Germany	272/33 R
1,621	11/1901	United Kingdom	272/33 B
692,886	8/1930	France	272/43

Primary Examiner—Anton O. Oechsle
Assistant Examiner—Arnold W. Kramer

[57] ABSTRACT

A generally circular base panel having a central area is provided for disposition on a horizontal support surface and a rotary platform is disposed above the base panel and includes support wheels rollingly engaged with the upper surface of the base panel. The platform is pivotally anchored to the base panel for rotation relative thereto about an upright axis extending through the central area of the base panel and the platform includes two relatively angulated generally straight sides converging toward a point at least closely adjacent the axis of rotation of the platform. The platform further includes a convex arcuate side interconnecting the divergent ends of the straight sides and having its opposite ends generally equally spaced from the axis of rotation of the platform relative to the base, the arcuate side of the platform extending through an arc of approximately ninety degrees. The platform has child support structure thereon and at least one child support structure includes a manually drivable wheel disposed outwardly of one of the straight sides of the platform and rollingly engaged with the base panel whereby a child disposed on the platform may drive the wheel and thus cause the platform to rotate about its axis of rotation relative to the base panel.

4 Claims, 3 Drawing Figures

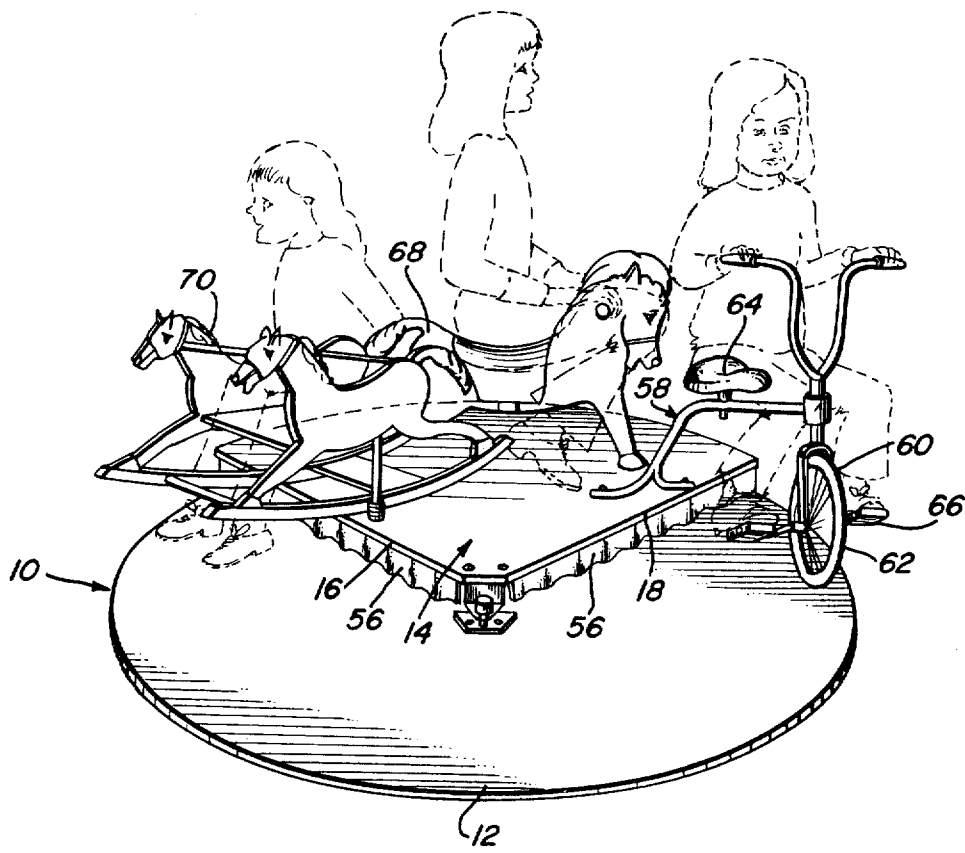

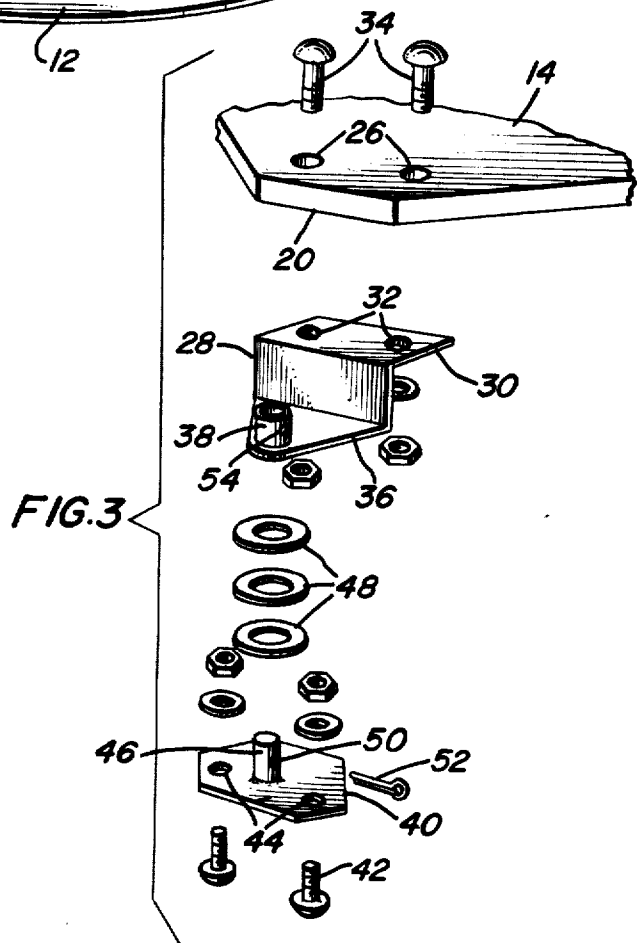
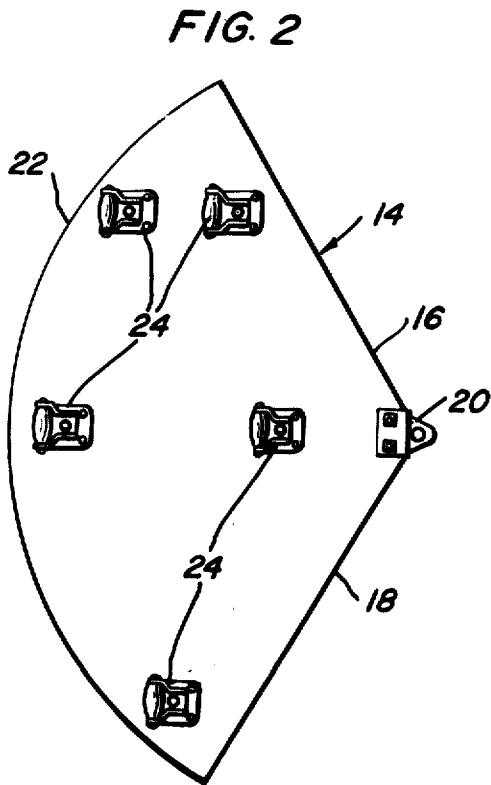
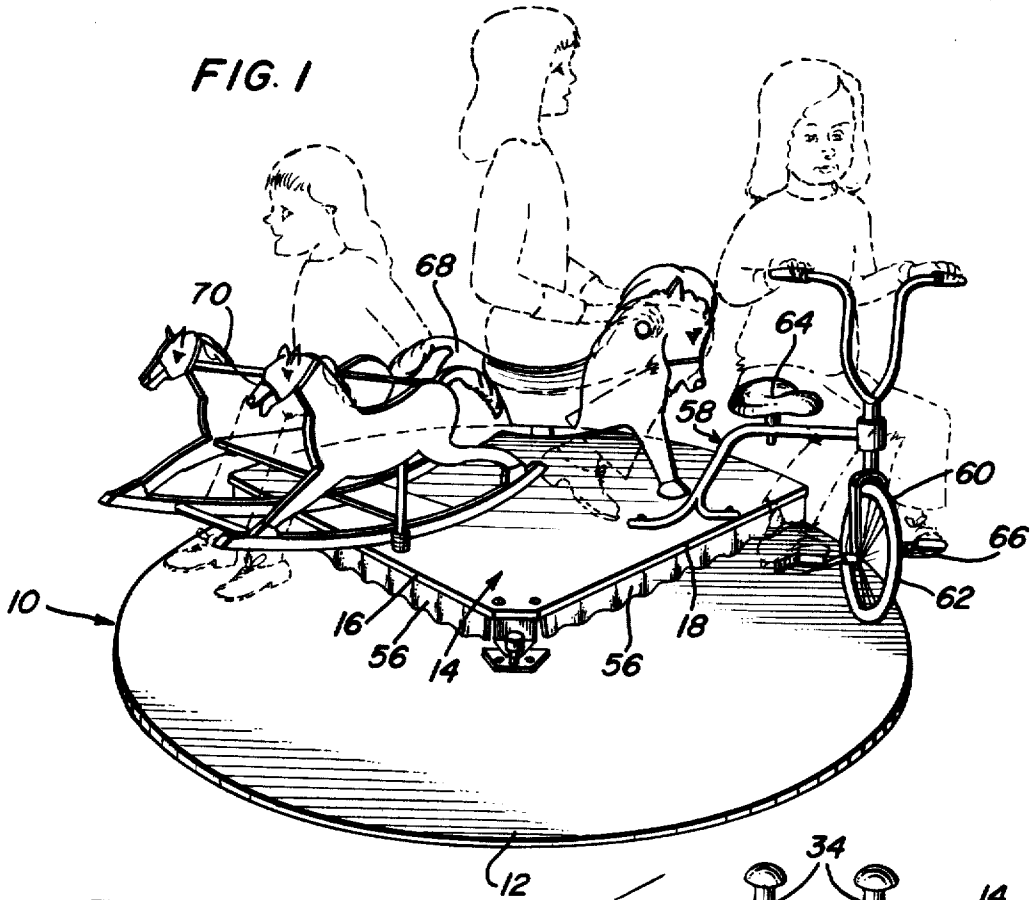

OCCUPANT PROPELLED ROUNDABOUT**BACKGROUND OF THE INVENTION**

The present invention relates to an occupant propelled roundabout for use by children and it has been designed to enable its use on substantially any reasonably horizontal support surface such as a lawn, a patio, a bare floor in a household or a carpeted household floor, etc. Roundabouts previously designed to be propelled by children through the utilization of a manually powered wheel have not included their own base panels upon which such powered wheels may roll and be afforded traction. In addition, some previous roundabouts utilize a full circular rotatable platform for supporting the occupants of the roundabout and it is necessary for the occupants of the roundabout to propel the rotatable platform thereof at a point outwardly beyond the outer periphery of the roundabout. This type of roundabout therefore requires the propelling mechanism for the child propelling the roundabout to be disposed outwardly of the outer periphery of the circular platform in a position to strike another child adjacent the roundabout watching the latter being used.

BRIEF DESCRIPTION OF THE INVENTION

The roundabout of the instant invention is provided with its own base panel and may therefore be used even on soft ground surfaces. Further, the roundabout utilizes only a one quarter circular platform and propelling structure to be driven by an occupant of the roundabout spaced within the circular path through which the platform is rotated when in use. Accordingly, the roundabout and child propelling the same in no way form a projection extending outwardly of the circular path in which the platform of the roundabout moves for striking a child adjacent the roundabout watching it in use.

Also, the propelling structure of the roundabout comprises a pedal-driven tricycle wheel rollingly engaged with that portion of the circular base panel which is not covered by the quarter circular support platform and thus the roundabout may be used on a lawn without injuring adjacent grass, it being understood that the roundabout will not be left in the same position on the lawn for a period of time which might cause permanent damage to the underlying grass.

The main object of this invention is to provide an occupant propelled roundabout which may be used both indoors and out-of-doors and which is constructed in a manner to reduce the possibility of a child standing near the roundabout being injured as the platform portion of the roundabout is rotated by children supported from the platform.

Another object of this invention is to provide a roundabout constructed in a manner such that the speed of rotation of the roundabout will be limited to a slower speed than that which can be attained by a child running about the periphery of a conventional roundabout.

A final object of this invention to be specifically enumerated herein is to provide an occupant propelled roundabout for children which will conform to conventional forms of manufacture, be of simple construction and easy to use so as to provide a device that will be economically feasible, long lasting and relatively trouble free in operation.

These together with other objects and advantages which will become subsequently apparent reside in the details of construction and operation as more fully hereinafter described and claimed, reference being had to the accompanying drawings forming a part hereof, wherein like numerals refer to like parts throughout.

BRIEF DESCRIPTION OF THE DRAWINGS

FIG. 1 is a perspective view of the roundabout;

FIG. 2 is a bottom plan view of the rotatable platform portion of the roundabout; and

FIG. 3 is a fragmentary exploded perspective view of the structure by which the platform portion of the roundabout is rotatably supported from the circular base of the roundabout.

DETAILED DESCRIPTION OF THE INVENTION

Referring now more specifically to the drawings, the numeral 10 generally designates the roundabout of the instant invention. The roundabout 10 includes a stiff circular base panel 12 and a generally one-quarter to one-third circular platform referred to in general by the reference numeral 14. The platform 14 includes a pair of relatively angulated generally straight sides 16 and 18 which converge toward an apex portion 20. The straight sides 16 and 18 extend generally radially outwardly from the apex portion 20 and are interconnected at their divergent ends by means of an arcuate side 22. The arcuate side 22 is outwardly convex and its opposite ends are spaced substantially equally from the apex portion 20. Further, the center of curvature of the arcuate side 22 is disposed closely adjacent the apex portion 20.

The underside of the platform 14 includes five caster ball assemblies 24 spaced thereabout and the apex portion 20 of the platform 14 has a pair of upstanding bores 26 formed therethrough. A generally Z-shaped mounting bracket 28 is provided and includes an upper horizontal flange 30 suitably apertured as at 32 with the apertures 32 registered with the bores 26 and threaded shank type fasteners 34 secured through the bores 26 and the apertures 32 in order to secure the mounting bracket 28 to the apex portion 20. The mounting bracket 28 additionally includes a lower outwardly projecting horizontal flange 36 and an outer portion of the flange 36 is apertured and has an abutment sleeve 38 positioned thereover in alignment with the aperture formed in the flange 36.

A mounting plate 40 is secured to the central area of the base panel 12 by means of threaded shank type fasteners 42 having their shank portions secured upwardly through the base panel 12 and apertures 44 formed in the mounting plate 40 and an upstanding journal pin 46 has its lower end secured to the mounting plate 40 and a plurality of washers 48 disposed thereover. The journal pin 46 is provided with a diametric bore 50 and the apertured outer end of the flange 36 is slipped over the upper end of the journal pin and downwardly along the pin to a point spaced below the diametric bore 50 with the washers 48 disposed between the flange 36 and the mounting plate 40. Then, a cotter pin 52 is passed through the diametrically opposite radial bores 54 formed in the abutment sleeve 38 and the diametric bore 50 formed in the journal pin 46. In this manner, the platform 14 is rotatably supported from the base panel 12.

The straight edge portions 16 and 18 of the platform 14 are provided with depending longitudinally extending skirt portions 56 and the arcuate edge portion 22 of the platform 14 may be provided with a similar depending skirt portion (not shown).

A tricycle frame referred to in general by the reference numeral 58 is secured to the upper surface of the straight edge portion 18 in a stationary manner and the front pedal-equipped wheel assembly 60 of the tricycle frame is welded or otherwise secured in a turned direction so that the wheel 62 will roll in a circular path about the base panel 12 a spaced distance inwardly of the outer periphery thereof. Of course, a child positioned on the seat 64 of the tricycle assembly 58 may have his feet engaged with the pedals 66 of the wheel assembly 60 and in this manner cause the platform 14 to be propelled about the base panel 12.

The platform 14 is also provided with a simulated pony 68 which may be ridden in the usual manner. However, the pony 68 is spaced closely adjacent the central area of the arcuate side 22 of the platform 14 and thus the outboard leg of the child riding the pony 68 may also be used to propel the platform 14.

A rocking horse assembly 70 is stationarily mounted on the straight edge portion 16 of the platform 14 and constructed in a manner whereby a child seated in the rocking horse assembly 70 will be facing in a rearward direction in relation to the direction of rotation of the platform 14 and may use his or her feet to propel the platform 14.

The foregoing is considered as illustrative only of the principles of the invention. Further, since numerous modifications and changes will readily occur to those skilled in the art, it is not desired to limit the invention to the exact construction and operation shown and described, and accordingly all suitable modifications and equivalents may be resorted to, falling within the scope of the invention.

What is claimed as new is as follows:

1. A roundabout comprising a generally circular base panel having a central area and adapted to be disposed in horizontal position on a horizontal support surface, a rotary platform disposed above said base panel and including supporting wheel means rollingly engaged with said base panel, means pivotally anchoring said

platform to said base panel for rotation of the platform relative to said base panel about an upright axis extending through said central area and adjacent a predetermined portion of said platform, said platform including two relatively angulated generally straight sides converging toward a point at least closely adjacent said predetermined platform portion, said platform including a convex arcuate side interconnecting the divergent ends of said straight sides and having the opposite ends of said arcuate side generally equally spaced from said axis, the included angle defined by said straight sides being at least 90 degrees and no more than 120 degrees, the distance between said opposite ends of said arcuate side and said axis being generally equal to the radius of said base panel, said supporting wheel means being disposed entirely beneath and dependently supported from said platform inwardly of said straight sides and said arcuate side, a pedal crank-equipped drive wheel journaled from said platform for rotation about an axis extending substantially radially of the axis of rotation of the platform relative to said base and a seat supported from said platform in position, relative to said wheel, such that a child seated on said seat may drive said wheel with his legs in the manner in which a child drives the front wheel of a tricycle, said wheel being rollingly engaged with an outer peripheral portion of said base panel and disposed entirely outwardly of one of said straight sides of said platform.

2. The combination of claim 1 wherein said supporting wheel means comprise caster ball assemblies.

3. The combination of claim 1 including a child support structure supported from said platform adjacent the other straight side thereof and adapted to have a child seated thereon in elevated position above said the other straight side with the child facing outwardly of said other side and having his feet supported from said base panel outwardly of said other one straight side.

4. The combination of claim 3 including a child support structure supported from said platform adjacent a mid-portion of said convex side and adapted to be straddled by a child with the latter facing in a direction generally tangent to said arcuate side and having his outermost leg and foot positioned for engagement with the surface upon which said base panel is supported.

* * * * *

50

55

60

65