

(19) World Intellectual Property Organization  
International Bureau



(43) International Publication Date  
19 February 2004 (19.02.2004)

PCT

(10) International Publication Number  
WO 2004/016064 A1

- (51) International Patent Classification<sup>7</sup>: **H05K 13/08**,  
13/04
- (21) International Application Number:  
PCT/JP2003/010044
- (22) International Filing Date: 7 August 2003 (07.08.2003)
- (25) Filing Language: English
- (26) Publication Language: English
- (30) Priority Data:  
2002-231811 8 August 2002 (08.08.2002) JP  
2002-328050 12 November 2002 (12.11.2002) JP
- (71) Applicant (for all designated States except US): **MAT-SUSHITA ELECTRIC INDUSTRIAL CO., LTD.** [JP/JP]; 1006, Oaza Kadoma, Kadoma-shi, Osaka 571-8501 (JP).
- (72) Inventors; and
- (75) Inventors/Applicants (for US only): **KAWASE, Takeyuki** [JP/JP]; 238-3-302, Furukamijomachi, Kofu-shi, Yamanashi 400-0051 (JP). **KINO, Toshiyuki** [JP/JP]; 1420-1-C201, Nanokaichiba, Yamanashi-shi, Yamanashi 405-0007 (JP). **YOSHITAKE, Takanori** [JP/JP]; 259-1-602, Miyabara-cho, Kofu-shi, Yamanashi 400-0058

(JP). **SANO, Kimiaki** [JP/JP]; 2352-B206, Kamisukiawara, Showa-cho, Nakakoma-gun, Yamanashi 409-3861 (JP). **HATTORI, Yoshiyuki** [JP/JP]; 2143-2-III201, Osato-cho, Kofu-shi, Yamanashi 400-0053 (JP). **YAZAWA, Takashi** [JP/JP]; 1250-10, Utsuya, Futaba-cho, Kitakoma-gun, Yamanashi 407-0108 (JP). **UCHIYAMA, Hiroshi** [JP/JP]; 891-II301, Horinouchimachi, Kofu-shi, Yamanashi 400-0056 (JP). **TANAKA, Youichi** [JP/JP]; 47-1-B202, Shinohara, Ryuo-cho, Nakakoma-gun, Yamanashi 400-0115 (JP). **IMAFUKU, Shigeki** [JP/JP]; 2004-1, Dodo, Minami-arupusu-shi, Yamanashi 400-0214 (JP). **KANETAKA, Iwao** [JP/JP]; 259-1, Miyabara-cho, Kofu-shi, Yamanashi 400-0058 (JP). **OGURA, Tamaki** [JP/JP]; 259-1-B513, Miyabara-cho, Kofu-shi, Yamanashi 400-0058 (JP).

- (74) Agents: **KAWAMIYA, Osamu** et al.; AOYAMA & PARTNERS, IMP Building, 3-7, Shiromi 1-chome, Chuo-ku, Osaka-shi, Osaka 540-0001 (JP).
- (81) Designated States (national): CN, US.
- (84) Designated States (regional): European patent (AT, BE, BG, CH, CY, CZ, DE, DK, EE, ES, FI, FR, GB, GR, HU, IE, IT, LU, MC, NL, PT, RO, SE, SI, SK, TR).

Published:  
— with international search report

[Continued on next page]

(54) Title: DEVICE AND METHOD FOR DETECTING WHETHER OR NOT COMPONENT HOLDER IS GOOD, AND APPARATUS AND METHOD FOR MOUNTING ELECTRONIC COMPONENT

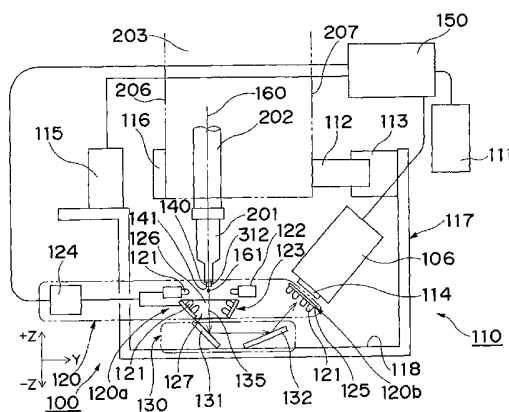

(57) Abstract: The present invention provides a device and a method for determining whether or not component holder is good, which enable detecting component holders that are to affect correct component recognition and further enable preventing interferences between constituent devices, a component mounting apparatus with the determining device, and a component mounting method. The determining device has an illuminating device (120), a CCD camera (106) and a controller (150) to determine whether or not a suction nozzle (201) is good based on a luminance at a component hold face (140) of the suction nozzle. The suction nozzle having the light reflectance of the component hold face increased to a level whereat the correct recognition of an electronic component (312) held by the suction nozzle is affected can be detected accordingly. An interference preventing device (320) is also provided, so that the interference between the CCD camera and the suction nozzle can be prevented.

WO 2004/016064 A1



- 
- *before the expiration of the time limit for amending the claims and to be republished in the event of receipt of amendments*
- For two-letter codes and other abbreviations, refer to the "Guidance Notes on Codes and Abbreviations" appearing at the beginning of each regular issue of the PCT Gazette.*

## DESCRIPTION

DEVICE AND METHOD FOR DETECTING WHETHER OR NOT  
COMPONENT HOLDER IS GOOD, AND APPARATUS AND METHOD FOR  
5 MOUNTING ELECTRONIC COMPONENT

## Technical Field

The present invention relates to a device and a  
method for detecting whether or not a component holder for  
10 holding, for instance, an electronic component or the like  
a component is good, and an apparatus and a method for  
mounting components with the detecting device.

## Background Art

15 Conventionally, as shown in Fig. 25, in a  
component mounting apparatus 10 for mounting electronic  
components 2 onto a circuit board 3, after the electronic  
component 2 is sucked to a suction face at a leading end of  
a suction nozzle 1, the electronic component 2 held by the  
20 suction nozzle 1 passes over an illuminating device 4  
during a time while the electronic component is moved to  
the circuit board 3. The illuminating device 4 illuminates  
a lower face of the electronic component 2 from below the  
electronic component 2 held by the suction nozzle 1, and a  
25 recognizer 5 carries out image-pickup operation of the

electronic component 2 by the reflecting light from the lower face. On a basis of the image-pickup information, a position deviation of the electronic component 2 sucked by the suction nozzle 1 is detected. The electronic component 5 2 having the position deviation detected is corrected in the position and then mounted onto a predetermined position of the circuit board 3.

In detecting the position deviation of the electronic component 2, particularly in a case where the suction face at the suction nozzle 1 has an area larger than an area of the electronic component 2 recognized by the recognizer 5, it is difficult to distinguish a reflecting light from the suction nozzle 1 including the suction face and the reflecting light from the electronic component 2 each other. Correct judgment of the position deviation of the electronic component 2 is hindered in some cases. For avoiding effects of the reflecting light from the suction nozzle 1 in the recognizer 5, the suction nozzle 1 is made from a material of a low reflectance, is coated for lowering the reflectance, or is adapted in the like way. 15 20

However, through repetition of the suction of the electronic components 2, the suction face of the suction nozzle 1 formed of the low reflectance material or subjected to the coating receives adhesion of metals of the 25

electronic components 2, or the coating of the suction face  
peels off, whereby the reflectance is increased. In  
consequence, if the electronic component 2 is small  
relatively to the suction face of the suction nozzle 1 as  
5 referred to above, the recognizer 5 detects the reflecting  
light from the suction face of the suction nozzle 1  
unfavorably, which leads to the trouble that the position  
of the electronic component 2 cannot be recognized  
correctly or the suction nozzle 1 is mistakenly recognized  
10 as holding the electronic component 2 although the suction  
nozzle 1 does not suck the electronic component 2.

#### Disclosure Of Invention

The present invention is developed to solve the  
15 above-described problems, and has for its object to provide  
a device and a method for detecting whether or not a  
component holder is good and an apparatus and a method for  
mounting components with the detecting device, which enable  
detecting the component holder that affect correct  
20 recognition of components and moreover enable preventing  
interferences between constituent devices.

In accomplishing the object, the present  
invention can be constituted as follows.

Namely, according to a first aspect of the  
25 present invention, there is provided a device for detecting

whether or not a component holder is good, which comprises:

an illuminating device for emitting light to the component holder having a component hold face with an area not smaller than a light reflection face of a component;

5 an image-pickup device for carrying out an image-pickup of the component hold face illuminated by the illumination of the illuminating device; and

a controller for determining whether or not the component holder is good on a basis of a luminance of the component hold face in image-pickup information of the component hold face supplied from the image-pickup device.

The above detecting device of the first aspect may be designed so that the controller has a setting value set on a basis of a total luminance by reflection from the component and the component hold face when the illuminating device emits light in a state with the component being held at the component hold face, so that determines that the component holder is defective when the luminance at the component hold face in a state without the component being held is not smaller than the setting value.

The above detecting device of the first aspect may be designed so that the controller has region information related to a plurality of sections obtained by dividing the component hold face and determines whether or not a luminance at each section is not smaller than the

setting value.

The above detecting device of the first aspect may be designed so that when the luminance is smaller than the setting value, the controller determines the component holder as defective if an image corresponding to the component is recognized within imaging information of the component hold face supplied from the image-pickup device.

The above detecting device of the first aspect may be designed so that the controller has information related to the image of the component recognized within the imaging information of the component hold face, the information related to the image being made image information of a size not larger than a minimum component to be held by the component holder.

The above detecting device of the first aspect may be designed so that the illuminating device emits light to the component holder by an amount of light for inspection which exceeds a maximum amount of light at a time when the illuminating device emits light to the component and the component hold face in a state with the component being held at the component hold face.

According to a second aspect of the present invention, there is provided a method for detecting whether or not a component holder is good, which comprises:

emitting light to a component holder having a

component hold face of an area not smaller than a light reflection face of a component;

carrying out of image-pickup of the illuminated component hold face; and

5 determining whether or not the component holder is good on a basis of a luminance of the component hold face in image-pickup information of the component hold face.

According to a third aspect of the present invention, there is provided a component mounting apparatus  
10 which comprises:

a device for detecting whether or not a component holder is good which includes: an illuminating device for emitting light to the component holder having a component hold face of an area not smaller than a light reflection  
15 face of a component, an image-pickup device for carrying out image-pickup of the component hold face illuminated by the illuminating device, and a controller for determining whether or not the component holder is good on a basis of a luminance of the component hold face in imaging information  
20 of the component hold face supplied from the image-pickup device;

a component supply device for supplying a component to be held by the component holder; and

a component load and transfer device with the  
25 component holder for holding the component from the

component supply device with the component holder and mounting the held component onto a circuit board.

The above component mounting apparatus of the third aspect may be designed so that the component load and transfer device has a detecting device supporter with a plurality of the component holders arranged in an array for holding the illuminating device and the image-pickup device disposed opposite to the component hold faces of the component holders and included in the detecting device, and a drive unit for moving the detecting device supporter in relation to the component holders along an arrangement direction of the component holders.

The above component mounting apparatus of the third aspect may be designed so that the apparatus further comprises a cleaning device for cleaning a component hold face of a defective component holder determined as defective by the detecting device.

The above component mounting apparatus of the third aspect may be designed so that the apparatus further comprises a holder replacement device for separating and holding a defective holder determined as defective by the detecting device from the component load and transfer device, and holding a spare component holder for the component holder installed in the component load and transfer device.

The above component mounting apparatus of the third aspect may be designed so that the component load and transfer device further has driving parts for ascent and descent installed corresponding to respective component holders for moving the component holders up and down, and a position detector for detecting a position of the image-pickup device moved by the drive unit along the arrangement direction of the component holders,

the component mounting apparatus further having a trigger signal generator for generating a trigger signal for moving down the component holders to the driving parts for ascent and descent,

so that the controller controls the driving parts for ascent and descent on a basis of the position of the image-pickup device by the position detector when the trigger signal is generated by the trigger signal generator.

According to a fourth aspect of the present invention, there is provided a component mounting method, in which whether or not a component holder is good is determined by carrying out a detecting method of determining whether or not the component holder is good on a basis of a luminance of a component hold face in imaging information of the component hold face by emitting light to the component holder having the component hold face of an area not smaller than a light reflection face of a

component and carrying out image-pickup of the illuminated component hold face after a component mounting operation of holding a component by the component holder and mounting the component to a circuit board is carried out by a set  
5 number of times before a next component mounting operation is started.

The above component mounting method of the fourth aspect may be designed so that in the component mounting operation when the components are sucked to the component  
10 holders by independently moving up and down a plurality of the component holders arranged linearly to each other, carried out the image-pickup of the components sucked by the component holders by an image-pickup device by moving the image-pickup device from below the component holders  
15 along an arrangement direction of the component holders, and mounted to the circuit board after the image-pickup,

a position of the image-pickup device with moving is detected, so that the downward movement of the component holders is controlled on a basis of the detected position.

20 According to the device of the first aspect of the present invention for detecting whether or not a component holder is good and the method of the second aspect for detecting whether or not a component holder is good, there are provided the illuminating device, the  
25 image-pickup device and the controller, thereby determining

whether or not the component holder is good on the basis of the luminance at the component hold face of the component holder. Hence it is made possible to detect a component holder having the reflectance of the component hold face increased to a level whereat correct recognition of the component held by the component holder is affected.

Whether or not component holder is good can be determined with a higher accuracy by dividing the component hold face to sections and measuring the luminance for each section.

In addition to measuring the luminance, image-pickup information of the component hold face is taken into account, so that the accuracy of determining whether or not the component holder is good is improved further.

When it is determined with the use of an amount of light for inspection whether or not the component holder is good, the amount of light for inspection exceeds an amount of light in a normal component recognition operation, so that the determination can be made with a higher accuracy.

In the component mounting apparatus of the third aspect and the component mounting method of the fourth aspect of the present invention, there is provided the detecting device of the first aspect and the detecting method is carried out, whereby contamination of the

component hold face of the component holder, peeling off of a coating, and the like can be detected before the component is held. Accordingly, wrong recognition of the component as a result of the reflection at the component  
5 hold face in a component recognition operation carried out before the component is mounted can be reduced.

The component load and transfer device is provided with the detecting device supporter and the drive unit. The need of moving the component load and transfer  
10 device to a position where the recognizer is disposed as in the conventional art is eliminated at a recognition time of components held by the component holders. The mounting cycle time is thus shortened and the availability in mounting components is increased consequently.

15 There is also provided the cleaning device. The component hold face of the component holder can be automatically cleaned when the component holder is determined as defective as a result of the detection whether or not the component holder is good.

20 When the holder replacement device is provided, the component holder can be automatically replaced with a normal suction nozzle if the component holder is not returned to the normal component holder in spite of cleaning by the cleaning device.

25 Moreover, there is the trigger signal generator

installed, and the component load and transfer device is provided with the position detector. While the image-pickup device moves along the arrangement direction of component holders, the downward movement of the component holder can be stopped when the image-pickup device is located below the descending component holder, thus enabling preventing interference between the component holder and the image-pickup device.

In addition, in the component mounting method of the fourth aspect, the position of the moving image-pickup device is detected, and the downward movement of the component holder is controlled on the basis of the detected position. Therefore, the downward movement of the component holder can be stopped if the image-pickup device is below the descending component holder. Interference between the component holder and the image-pickup device can be prevented accordingly.

#### Brief Description Of Drawings

These and other aspects and features of the present invention will become clear from the following description taken in conjunction with the preferred embodiments thereof with reference to the accompanying drawings, in which:

Fig. 1 is a side view showing the configuration

of a device for detecting whether or not a suction nozzle is good according to a first embodiment of the present invention;

Fig. 2 is a plane view of an illuminating device  
5 for suction nozzle of the detecting device shown in Fig. 1;

Fig. 3 is a diagram showing a lens part light source support member included in the detecting device of Fig. 1;

Fig. 4 is a perspective view showing the  
10 configuration of a transfer head part in the first embodiment of the present invention;

Fig. 5 is a perspective view showing the configuration of an electronic component mounting apparatus having the detecting device in the first embodiment of the present invention;  
15

Fig. 6 is a diagram showing the configuration of a controller of the electronic component mounting apparatus with the detecting device in the first embodiment of the present invention;

Fig. 7 is a flow chart diagram of the electronic component mounting apparatus with the detecting device in the first embodiment of the present invention;  
20

Fig. 8 is a diagram showing the correspondence between suction nozzles and electronic components in the electronic component mounting apparatus with the detecting  
25

device according to the first embodiment of the present invention;

Fig. 9 is a diagram showing an image-pickup state in measuring the luminance at a component hold face in a normal state without any adhesion of metals or the like contamination to the component hold face of the suction nozzle;

Fig. 10 is a diagram showing a relation between a threshold and a defective nozzle;

Fig. 11 is a diagram showing a state in which the component hold face of the suction nozzle soaks in a solvent of a solvent bath part in a cleaning device;

Fig. 12 is a diagram showing a state in which the component hold face of the suction nozzle is pressed against a liquid absorber of a solvent wiping part in the cleaning device;

Fig. 13 is a diagram showing a state in which the component hold face of the suction nozzle is pressed against a contamination wiper of a finishing part in the cleaning device;

Fig. 14 is a diagram showing an image-pickup state in measuring the luminance at the component hold face in a state with the adhesion of metals or the like contamination present at the component hold face of the suction nozzle without sucking the component;

Fig. 15 is a diagram showing an image-pickup state in measuring the luminance at the component hold face in a state with the adhesion of metals or the like minute contamination present at the component hold face of the suction nozzle without sucking the component;

Fig. 16 is a diagram showing an image-pickup state in measuring the luminance at the component hold face in a state where the adhesion of metals or the like contamination to the component hold face of the suction nozzle without sucking the component is present in a region to be hidden by a sucked electronic component;

Fig. 17 is a diagram in which the image-pickup state in measuring the luminance at the component hold face in a state with the adhesion of metals or the like contamination present at the component hold face of the suction nozzle without sucking the component is divided to each of sections;

Fig. 18 is a diagram showing the image-pickup state at the component hold face in a state with the adhesion of metals or the like contamination present at the component hold face of the suction nozzle without sucking the component, and an area stored in the controller;

Fig. 19 is a diagram showing a configuration of a modified example of the electronic component mounting apparatus of Fig. 5 with an interference preventing device

installed thereto;

Fig. 20 is a flow chart explanatory of the operation at the interference preventing device shown in Fig. 19;

5 Fig. 21 is a diagram of a modified example of photosensors and dogs which constitute the interference preventing device of Fig. 19;

Fig. 22 is a diagram of a modified example of the interference preventing device of Fig. 19;

10 Fig. 23 is a diagram showing waveform examples of signals sent out from the interference preventing device of Fig. 22;

Fig. 24 is a flow chart explanatory of operation in the interference preventing device of Fig. 22; and

15 Fig. 25 is a perspective view showing a configuration of a conventional electronic component mounting apparatus.

#### Best Mode for Carrying Out the Invention

20 A device and a method for detecting whether or not a component holder is good, and an apparatus and a method for mounting components according to preferred embodiments of the present invention will be described in detail with reference to the attached drawings. The method  
25 for detecting whether or not the component holder is good

is a detection method carried out by the device for detecting whether or not the component holder is good, the component mounting apparatus is a mounting apparatus with the detecting device, and the component mounting method is  
5 a mounting method carried out by the component mounting apparatus. Like parts are designated by like reference numerals throughout the drawings.

The component mounting apparatus with the detecting device will be described first. As shown in Fig.  
10 5, a component mounting apparatus 300 fundamentally comprises a detecting device 100 to be detailed later for detecting whether or not a component holder is good, a component supply device 305, a component load and transfer device 200, and a controller 150. According to the  
15 embodiment, there are also arranged on a base 309, a loader part 302, a circuit board hold part 303, an unloader part 304, a suction nozzle changer 310 corresponding to an example functioning as a holder replacement device, and a cleaning device 311. In the component mounting apparatus  
20 300, the component supply device 305 has a first component supply part 305A, a second component supply part 305B and a third component supply part 305C, while the component load and transfer device 200 has a transfer head part 210 and an XY-robot 308.

25 The loader part 302 is a device for carrying an

electronic circuit board 301 supplied from an upstream side which is the side of a pre process of the component mounting apparatus 300 into the circuit board hold part 303. The circuit board hold part 303 is a device for holding the  
5 electronic circuit board 301 carried in from the loader part 302 and making the circuit board 301 movable in X and Y-directions to position the circuit board to a predetermined position in a component mounting operation. The unloader part 304 is a device for transferring, after  
10 mounting of components, the electronic circuit board 301 carried out from the circuit hold part 303 towards a downstream side which is the side of a post process of the component mounting apparatus 300. The loader part 302, the circuit board hold part 303 and the unloader part 304 are  
15 arranged at a nearly central part of the base 309 in this order from the upstream to the downstream along the X-axis direction.

The first component supply part 305A and the second component supply part 305B are devices for supplying  
20 electronic components 312 for the component mounting, which are so-called parts cassette type component supply devices for supplying components by transferring a tape respectively in which the electronic components 312 are stored. The third component supply part 305C is a so-  
25 called tray type component supply device for supplying

electronic components 312 arranged in a grid pattern on a tray. The first component supply part 305A and the third component supply part 305C are disposed opposite to each other along the Y-direction via the circuit board hold part 5 303, and the second component supply part 305B is arranged at the upstream side in a board transfer direction with respect to the third component supply part 305C.

The suction nozzle changer 310 is always equipped with one or more spare nozzles 313 which is a member as an 10 example exerting the function of the component holder and which corresponds to a spare component holder of the same kind as or a different kind from a suction nozzle 201 of the transfer head part 210. Also the suction nozzle changer 310 is the device for supplying a desired suction 15 nozzle 201 to the transfer head part 210. The suction nozzle changer 310 is arranged between the third component supply part 305C and the second component supply part 305B in the present embodiment.

The cleaning device 311 has a solvent bath part 20 901, a solvent wiping part 902 and a finishing part 903. The solvent bath part 901 having a solvent 910 injected therein is a bath for cleaning the suction nozzle 201 by the solvent 910. For the solvent 910, for example, ethanol or isopropyl alcohol can be used. The solvent wiping part 25 902 is a device for wiping the solvent 910 adhering to the

suction nozzle 201 after the suction nozzle 201 is cleaned at the solvent bath part 901, which has a cloth-shaped liquid absorber 911 set on an XY-plane. For example, a water-absorbing waste or the like is utilizable as the cloth-shaped liquid absorber 911. The finishing part 903 is a device for wiping stain or the like adhering to the suction nozzle 201, having a cloth-shaped contamination wiper 912 set on an XY-plane. For the cloth-shaped contamination wiper 912, for instance, chamois leather or the like is usable. The cleaning device 311 having the solvent bath part 901, the solvent wiping part 902 and the finishing part 903 is arranged at the upstream side of the suction nozzle changer 310 in the transfer direction of the circuit board 301. The solvent bath part 901, the solvent wiping part 902 and the finishing part 903 are arranged in this order along the X-axis direction from the upstream side to the downstream side.

The transfer head part 210 is a device for sucking electronic components 312 from the first component supply part 305A, the second component supply part 305B and the third component supply part 305C by suction nozzles 201. The XY-robot 308 has an X-axis robot 307, and a first Y-axis robot 306A and a second Y-axis robot 306B which are arranged at both ends of the X-axis robot 307 and have ball screw mechanisms rotating synchronously with each other so

that the X-axis robot 307 is driven in the Y-axis direction. The transfer head part 210 is loaded on the X-axis robot 307. The transfer head part 210 having suction nozzles 201 for sucking electronic components 312 is thus made movable  
5 above the base 309 in the X and Y-directions.

In the present embodiment, the detecting device 100 is installed at the transfer head 210, which will be depicted in detail below.

As shown in Fig. 4, the transfer head part 210  
10 has nozzle setting heads 202 to which suction nozzles 201 that is a member as an example exerting the function of the component holder are attached detachably, driving parts 204 for ascent and descent which move the nozzle setting heads 202 up and down along the Z-axis direction equivalent to an  
15 axis direction of the suction nozzles 201, driving parts 205 for rotation which rotate the suction nozzles 201 in a direction about the axis thereof, and the detecting device 100 for detecting whether or not the component holder is good.

20 According to the embodiment as is illustrated, there are 8 driving parts 204 arranged in parallel to each other along the X-axis direction at a head member 203 which constitutes the transfer head part 210, and the nozzle setting head 202 is installed to the each driving part 204.  
25 In other words, a total of 8 nozzle setting heads 202, that

is, 8 suction nozzles 201 are arranged along the X-axis direction. Four nozzle setting heads 202 are driven by one driving part 205 according to the present embodiment, and therefore a total of two driving parts 205 are installed at  
5 the head member 203. Each suction nozzle 201 is connected to a suction device 290 for sucking electronic components 312.

Similar to the conventional art, each of the suction nozzles 201 is formed of a material low in the  
10 reflectance or is subjected to coating for decreasing the reflectance so as to prevent light reflection from the suction nozzle 201 at a time of carrying out image-pickup of a hold posture of the electronic component 312. The whole of the suction nozzles 201 including component hold  
15 faces are coated with a frosted black color in the present embodiment.

The number of suction nozzles 201, i.e., the number of driving parts 204 for ascent and descent, and the number of driving parts 205 for rotation are not limited to  
20 those of the present embodiment.

The detecting device 100 for detecting whether or not component holders are good includes, as indicated in Fig. 1, a nozzle detector driving part 110, an illuminating device 120, a light guide part 130, a CCD camera 106  
25 corresponding to an example exerting the function as an

image-pickup device, and the controller 150. The detecting device 100 is a device for carrying out image-pickup operation of the component hold face 140 of the suction nozzle 201 from below the suction nozzle 201, thereby  
5 determining based on the image-pickup information whether the suction nozzle 201 is good or not. In the embodiment, the illuminating device 120, the light guide part 130 and the CCD camera 106 are installed to the head member 203 of the transfer head part 210 in a manner to be freely moved  
10 under each suction nozzle 201 by the nozzle detector driving part 110 along the X-axis direction.

In Fig. 1, the nozzle detector driving part 110 has a camera stage 117 where the illuminating device 120, the light guide part 130 and the CCD camera 106 are loaded  
15 and which corresponds to an example exerting the function of a detecting device supporter, a guide rail 112 attached along the X-axis direction to the head member 203 of the transfer head part 210 for supporting the camera stage 117 via a sliding member 113 and for guiding the camera stage  
20 117 to move in the X-axis direction, a linear scale 116 fitted along the X-axis direction to the head member 203, a linear sensor 115 installed to the camera stage 117 to be opposite to the linear scale 116 for reading the linear scale 116, and a detecting device driving motor 111  
25 operation-controlled by the controller 150 on a basis of

position information obtained from the linear sensor 115 for moving and positioning the camera stage 117 in the X-axis direction. The above guide rail 112, linear scale 116, linear sensor 115 and detecting device driving motor 111 correspond to a drive unit for moving the detecting device supporter in the X-axis direction corresponding to an arrangement direction of suction nozzles 201. The linear sensor 115 and the linear scale 116 constitute an example exerting the function of a position detector.

For detecting the position in the X-axis direction of the camera stage 117, the linear sensor 115 and the linear scale 116 are used in the present embodiment. However, the method is not specifically limited to these means, and a control with a linear motion amount obtained by an encoder of a servomotor may be employed although it depends on a positioning accuracy.

Fig. 1 is a view of the detecting device 100 seen from the X-axis direction in Fig. 4, in which a virtual point 161 is present on a virtual axis 160 supposed to be a parallel axis to the Z-axis which passes the center of the suction nozzle 201 and the nozzle setting head 202.

The camera stage 117 is set below the head member 203 and is a U-shaped member having a bottom plate 118 opposed to the component hold face 140 of the suction nozzle 201. The light guide part 130 is installed between

the bottom plate 118 and the component hold face 140, and the illuminating device 120 is arranged to be above the light guide part 130 and below the component hold face 140.

The illuminating device 120 is a device for shedding light onto the component hold face 140 of the suction nozzle 201 and to a light reflection face 141 which is a face opposite to a face to be held of the electronic component 312 sucked and held at the component hold face 140, and also shedding light onto the light guide part 130.

10 The illuminating device 120 is roughly divided to an illuminating device 120a for suction nozzles which is disposed in the vicinity of the suction nozzle 201 and an illuminating device 120b for camera which is disposed in the vicinity of a lens part 114 of the CCD camera 106. The

15 illuminating device 120a has a plurality of light sources 121 comprising, for example, LEDs (light emitting diodes), an upper light source part 122 where light sources 121 are disposed to have optical axes made horizontal, a lower light source part 123 where light sources 121 are disposed

20 to have optical axes inclined, and a power supply 124 connected to light sources 121 and luminance-controlled by the controller 150.

The lower light source part 123 has a lower first support member 123a and a lower second support member 123b

25 inclined and opposed to each other, and a lower third

support member 123c and a lower fourth support member 123d inclined and opposed to each other as shown in Fig. 2 so that a square large aperture 126 having a large area is formed to a position at the side of the component hold face 5 140 of the suction nozzle 201 and a square small aperture 127 having a small area is formed to a position at the side of the light guide part 130. The lower first support member 123a, the lower second support member 123b, the lower third support member 123c and the lower fourth support member 123d are inclined by an angle of 45 degrees to a horizontal direction. The lower first support member 123a, the lower second support member 123b, the lower third support member 123c and the lower fourth support member 123d form a roughly mortar-like shape. The lower light source part 123 is fixed to the camera stage 117 so that 15 the centers of the large aperture 126 and the small aperture 127 are present on the virtual axis 160 as the center of the suction nozzle 201.

Also as indicated in Fig. 2, each of the lower 20 first support member 123a, the lower second support member 123b, the lower third support member 123c and the lower fourth support member 123d has three light sources 121 installed at equal intervals near the center of each member, and two light sources 121 interposed between the three 25 light sources 121 to be in parallel to an arrangement

direction of the three light sources 121. Five light sources are installed in all. Each light source 121 is set to have its optical axis made orthogonal to the support member 123a or the like to which the light source 121 is fitted. By this arrangement, illumination light by each of light sources 121 set in the lower first support member 123a, the lower second support member 123b, the lower third support member 123c and the lower fourth support member 123d is concentrated to the vicinity of the virtual point 161 on the virtual axis 160.

Although the number of light sources 121 installed in the lower first support member 123a or the like is made five, the number is not specified and changeable in accordance with a distance between the component hold face 140 of the suction nozzle 201 and the light reflection face 141 of the electronic component 312 to be illuminated by the light sources 121, and the light sources 121, or the like.

The upper light source part 122 is disposed between the square large aperture 126 formed in the roughly mortar-like shape by the lower light source part 123 and the component hold face 140 of the suction nozzle 201. As shown in Fig. 2, the upper light source part 122 has an upper first support member 122a and an upper second support member 122b arranged opposite to each other, and an upper

third support member 122c and an upper fourth support member 122d arranged opposite to each other on diagonals at four corners of the large aperture 126. Each of the upper first support member 122a, the upper second support member, 5 the upper third support member and the upper fourth support member has three light sources 121 fitted at equal intervals in the vicinity of the center of each member so that optical axes of each source are made in the horizontal direction. This arrangement also makes the illumination 10 light by each light source 121 of the upper light source part 122 concentrated to the vicinity of the virtual point 161 on the virtual axis 160.

While the number of light sources 121 fitted to the upper first support member 122a or the like which 15 constitutes the upper light source part 122 is three in the present embodiment, the number is not specified and is changeable according to a distance between the component hold face 140 of the suction nozzle 201 and the light reflection face 141 of the electronic component 312 to be 20 illuminated by the light sources 121, and the light sources 121, or the like.

The illuminating device 120b for camera has a plurality of the light sources 121, a lens part light source support member 125 to which the light sources are 25 fitted, and the power supply 124 connected to the light

sources 121 and luminance-controlled by the controller 150. As shown in Fig. 3, the lens part light source support member 125 has an aperture 125a near the center thereof for passing the light entering the lens part 114 of the CCD camera 106, and 8 light sources 121 fitted at equal intervals along the periphery of the aperture 125a. The 8 light sources 121 are fitted so that optical axes of the light sources 121 are orthogonal to the lens part light source support member 125. Therefore, the illumination light by the light sources 121 fitted to the lens part light source support member 125 is irradiated towards the light guide part 130. The CCD camera 106 is a device for carrying out image-pickup of the component hold face 140 of the suction nozzle 201 and the light reflection face 141 of the electronic component 312 and is connected to the controller 150.

While the number of light sources 121 fitted to the lens part light source support member 125 is made 8 in the embodiment, the number is not specified and can be changed depending on a distance between the component hold face 140 of the suction nozzle 201 and the light reflection face 141 of the electronic component 312 to be illuminated by the light sources 121, and the light sources 121, or the like. Moreover, although the present embodiment uses the CCD camera 106, the embodiment is not limited to the CCD

camera 106 so long as the image-pickup of the component hold face 140 and the light reflection face 141 can be carried out. For example, an optical camera, a line sensor, a two-dimensional sensor, a three-dimensional sensor or the like can be used.

The light guide part 130 is a constituent part for guiding images of the component hold face 140 of the suction nozzle 201 and the light reflection face 141 of the electronic component 312 to the lens part 114 of the CCD camera 106, which includes a first reflecting mirror 131 arranged near the virtual axis 160 and a second reflecting mirror 132 arranged away from the first reflecting mirror 131 in the Y-axis direction. According to the embodiment, the first reflecting mirror 131 is disposed in a state while inclined by 45 degrees from a horizontal state in the clockwise direction about the X-axis so as to image the component hold face 140 and the light reflection face 141. The second reflecting mirror 132 is inclined by 25 degrees from a horizontal state in the counterclockwise direction about the X-axis and is disposed to a position where the mirror receives light from the illuminating device 120b for camera. The CCD camera 106 disposed not to be opposite to the component hold face 140 is hence enabled to image the component hold face 140 and the light reflection face 141 via the light guide part 130.

While the image-pickup operation is carried out with the use of the light guide part 130 in the instant embodiment, the light guide part 130 can be omitted if the CCD camera 106 can be disposed to be opposite to the component hold face 140. The number of reflecting mirrors for constituting the light guide part 130 can be changed depending on an arrangement state of the CCD camera 106.

An image-pickup operation of the suction nozzle 201 by the illuminating device 120, the light guide part 130 and the CCD camera 106 constituted as above will be described herein. In the first place, light sources 121 installed in the upper light source part 122 and the lower light source part 123 shine light on the suction nozzle 201. As a result, a reflecting light 135 reflected at the component hold face 140 of the suction nozzle 201 travels in the Z-direction towards the first reflecting mirror 131. The reflecting mirror 135 is changed by 90 degrees of a traveling angle by the first reflecting mirror 131 to travel further in the Y-direction towards the second reflecting mirror 132. Moreover, the reflecting light 135 has its traveling direction changed by 130 degrees by the second reflecting mirror 132 and enters the lens part 114 of the CCD camera 106. Imaging information sent out from the CCD camera 106 is temporarily stored in the controller 150.

The reflecting light 135 traveling from the second reflecting mirror 132 to the lens part 114 is adapted to enter by an angle of 85 degrees to the lens part 114 face so as not to be reflected regularly to the lens part 114 of the CCD camera 106.

The controller 150 will be discussed now. As shown in Fig. 6, the controller 150 is connected to the loader part 302, the circuit board hold part 303, the unloader part 304, the XY-robot 308, the first component supply part 305A, the second component supply part 305B, the third component supply part 305C, the transfer head part 210, the suction nozzle changer 310 and a database part 401. The database part 401 has a component library 402, an NC program 403, a board data 404 and a nozzle data 405 stored therein. The component library 402 has data on shapes of various kinds of electronic components 312 and is used in detecting a position deviation in a suction operation of the electronic component through comparison with image-pickup information to be described later. The NC program 403 is a program for driving each device of the component mounting apparatus 300. The board data 404 has shape data of various electronic circuit boards 301 and position data of various electronic components 312 to be mounted. The nozzle data 405 is data for sending to the suction nozzle changer 310 or the like, an instruction of

which of various suction nozzles 201 are to be used for various electronic components 312 to be held.

Although detailed in the operation description below, according to the present embodiment, the controller  
5 150 also has a deciding device 151 for determining whether or not the suction nozzle 201 is good on the basis of the luminance of the component hold face 140 in image-pickup information of the component hold face 140 of the suction nozzle 201 supplied from the CCD camera 106 and also on the  
10 basis of the image-pickup information itself. The deciding device 151 has a storage part 152 in which a setting value set on the basis of a total luminance by the reflection from the electronic component 312 and the component hold face 140 when the illuminating device 120 emits light in a  
15 state with the electronic component 312 being held at the component hold face 140 is stored. The deciding device 151 decides that the suction nozzle 201 is defective when the luminance at the component hold face 140 in a state without the component being held is not smaller than the setting  
20 value. The storage part 152 may be installed in the controller 150.

The deciding device 151 has region information related to a plurality of sections formed by dividing the component hold face 140, and determines for every section  
25 whether or not the luminance is not smaller than the

setting value. The storage part 152 may store the region information.

When the luminance is smaller than the setting value and if an image corresponding to the electronic component 312 is recognized within the image-pickup information of the component hold face 140 supplied from the CCD camera 106, the deciding device 151 can decide the suction nozzle 201 as defective.

The deciding device 151 may contain information related to the image of electronic component 312 recognized within the image-pickup information of component hold face 140, in the storage part 152. The image-pickup information at this time is preferably such that has a size of not larger than a minimum component to be held by the suction nozzle 201.

The controller 150 can operation-control the illuminating device 120 so that the illuminating device 120 emits light to the suction nozzle 201 by an amount of light for inspection which exceeds a maximum amount of light at a time when the illuminating device emits light to the electronic component 312 and the component hold face 140 in a state while the electronic component 312 is held at the component hold face 140.

In the present embodiment as described above, the detecting device 100 for component holders is installed at

the transfer head 210 included in the component mounting apparatus 300. However, the detecting device 100 can be constituted separately from the component mounting apparatus 300.

5           While the operation in the above-constituted component mounting apparatus 300 will be described below, one of operations characteristic of the present embodiment is a detection operation of deciding whether or not the suction nozzle 201 is good on the basis of a luminance or  
10 the like of the component hold face 140 of the suction nozzle 201 by light emission of the illuminating device 120, and therefore the detection operation in the component mounting apparatus 300 will be primarily described herein. The detection operation and the component mounting  
15 operation are both operation-controlled and carried out by the controller 150.

In the component mounting apparatus 300, the detection operation for the suction nozzle 201 is executed before the component mounting operation of the electronic  
20 component 312 to the circuit board 301 is started or after the component mounting operation is carried out by a predetermined number of times.

The detecting device 100 determines that the suction nozzle 201 having the light reflectance at the  
25 component hold face 140 increased because of adhesion of

metals of the electronic component 312 to the component hold face 140 of the suction nozzle 201 or by peeling of the coating at the component hold face 140 is a defective one. The detection operation for the suction nozzle 201 will be discussed with reference to Fig. 7.

In step 1, it is determined for the suction nozzle 201 to be inspected whether or not it is an object nozzle to be decided. In other words, in step 1, it is determined whether the component hold face 140 of the suction nozzle 201 is larger than or nearly equal in terms of the area to the light reflection face 141 which is opposite to a face to be held of the electronic component 312 by the suction nozzle 201 and reflects the light emitted from the illuminating device 120. The decision whether the suction nozzle 201 is good or not is carried out when the component hold face 140 is larger than or nearly equal to the light reflection face 141.

As indicated in Fig. 8, for example, each of an SX nozzle as the suction nozzle 201 for electronic components such as 0.6x0.5mm capacitors or resistors, an SA nozzle as the suction nozzle 201 for electronic components such as 1.0x0.5mm capacitors or resistors, or SS mini transistors, an S nozzle as the suction nozzle 201 for electronic components such as 1.6x0.8mm capacitors or resistors, 2.0x1.25mm capacitors or resistors, or 2x2.1mm S

mini transistors, and an M nozzle as the suction nozzle 201 for 6x3.5mm tantalum capacitors, 4.5x3.8mm trimming potentiometers or 4.3x4.3mm alumina electrolytic capacitors has the component hold face 140 larger than or nearly equal to the light reflection face 141 of the electronic component to be held, and therefore is subjected to the determination whether the suction nozzle 201 is good or not. On the other hand, an L nozzle as the suction nozzle 201 for SOPs having 7.6mm or larger dimensions or QFPs having 12mm or larger dimensions has the component hold face 140 smaller than the light reflection face 141 of the electronic component, and therefore is not subjected to the determination whether the suction nozzle 201 is good or not.

By way of example, the component hold face of the SX nozzle is 0.6x0.5mm, that of the SA nozzle is 1.0x0.8mm, that of the S nozzle is 1.7x1.2mm and that of the M nozzle is 4.0x3.4mm.

When it is not necessary to take into account effects of the reflecting light of the component hold face 140 at an operation of recognizing the suction posture of the electronic component 312, the determination of good or not for the suction nozzle 201 may be carried out even if the suction nozzle 201 has the component hold face 140 smaller than the light reflection face 141 of the electronic component 312. For instance, in the case where

some stain adheres to the component hold face 140 of the suction nozzle 201 to cause a suction failure and for the purpose of preventing such trouble, the component hold faces 140 of all suction nozzles 201 may be subjected to the determination of good or not regardless of the sizes of the component hold face 140 and the light reflection face 141.

Step 1 proceeds to step 2 when the suction nozzle is decided as an inspection object. Step 1 proceeds to step 10 when the suction nozzle is decided as a non inspection object. In step 10, the step returns to step 1 when the component mounting operation is to be continued, or the operation is terminated when the component mounting operation is not to be continued.

Since an increase of the light reflectance at the component hold face 140 is proportional to the number of employment of the suction nozzle 201, it is decided in step 2 whether or not the number of employment of the suction nozzle 201 to be inspected reaches a setting number. Unless the number of employment reaches the setting number, the step goes to step 4, where 1 is added to the number of employment. After the mounting operation is carried out there, the step goes back to step 1. In the meantime, if the number of employment of even one of 8 suction nozzles 201 in the embodiment of the transfer head 210 reaches the

setting number, the step moves to step 3, and the detecting device 100 is activated to decide whether or not the suction nozzle is good. Whether the suction nozzle is defective or not is discriminated in step 5.

5           Hereinbelow will be described the determination operation of good or bad for the suction nozzle by the detecting device 100.

          As shown in Fig. 9, in a state where the electronic component 312 corresponding to a suction nozzle  
10   650 of the same kind as the suction nozzle 201 to be inspected is sucked to a normal component hold face 651 having no adhesion of metals or the like thereto or without any peeling of the coating for suppressing light reflection, light is emitted by the illuminating device 120 and then  
15   image pickup operation is carried out by the CCD camera 106. At this time, the illuminating device 120 emits light with a maximum amount of light in a necessary amount of light for carrying out the image-pickup operation of the suction posture of the electronic component. Obtained image-pickup  
20   information is sent from the CCD camera 106 to the controller 150. For improving the inspection accuracy more, light can be emitted with an amount of light for inspection exceeding the maximum amount of light. The amount of light for inspection is approximately 110-120% of the maximum  
25   amount of light in an example.

The controller 150 measures a total luminance by the reflection from the light reflection face 141 of the electronic component 312 held by the suction nozzle 650 and the component hold face 651 of the suction nozzle 650.

5 Since the electronic component 312 normally reflects light considerably greatly in comparison with the component hold face 651, the total luminance can be normally regarded as a luminance mostly from the electronic component 312. In measuring the luminance, a luminance at an entire face of

10 the component hold face 651 may be measured, or a luminance at a setting range 610 shown in Fig. 9 may be measured. The setting range 610 is equal or nearly equal in size to the electronic component to be held. Specifically, the setting range is smaller by 10-30% than the component hold

15 face of the suction nozzle. A numeral 604 in Fig. 9 indicates a suction hole in the suction nozzle 650.

A maximum value of the measured total luminance is set as an upper limit threshold, and a luminance slightly smaller than the upper limit threshold is set as a

20 setting value 652 for determining whether or not the suction nozzle is good. The setting value is stored in the storage part 152. When the luminance is expressed by a 256-level gray scale by way of example as shown in Fig. 10, the setting value 652 may be decided to be, for example,

25 the 100-gradation level on the basis of the 120-gradation

level as an example of the upper limit threshold. The 120-gradation level corresponds to the total luminance.

The above setting value 652 is decided for each of various kinds of suction nozzles before the  
5 determination operation of good or bad for the suction nozzle is carried out, and each setting value 652 is stored.

Subsequently, image pickup operation of the component hold face 141 of the suction nozzle 201 is carried out, and whether the suction nozzle 201 is good or  
10 not is determined on the basis of the image-pickup information. More specifically, since the transfer head part 210 has a plurality of suction nozzles 201 in the present embodiment, it is necessary to position the camera stage 117 including the illuminating device 120, the light  
15 guide part 130 and the CCD camera 106 to each of the suction nozzles 201. In other words, the camera stage 117 is moved in the X-axis direction by the inspecting device driving motor 111, thereby positioning the virtual axis 160 as the center of the suction nozzle 201 to the centers of  
20 the large aperture 126 and the small aperture 127 of the lower light source part 123 on the basis of position information detected by the linear scale 116 and the linear sensor 115. The image of the component hold face 140 of the suction nozzle 201 when positioned as above is guided  
25 to the CCD camera 106 through the light guide part 130.

The image-pickup of the component hold face 140 is carried out by light emission from the illuminating device 120 by the maximum amount of light or by the amount of light for inspection. The luminance of the component hold face 140 is measured by the deciding device 151 on the basis of the image-pickup information, and whether or not the measured value is not smaller than the setting value 652 is determined. Since the light reflection at the component hold face 140 is large when the measured value is not smaller than the setting value 652, it is conceivable that metals such as solder of the electronic component 312 adhere or the coating is peeled out, whereby the suction nozzle 201 is determined as defective. On the other hand, when the measured value is smaller than the setting value 652, the suction nozzle 201 is determined as normal.

The camera stage 117 may be stopped every time the virtual axis 160 is positioned to the lower light source part 123 and the upper light source part 122 for each suction nozzle 201. However, for shortening the inspecting time, it is preferred to move the camera stage 117 in the X-axis direction without stopping, and activate the illuminating device 120 and the CCD camera 106 on the basis of the position information detected by the linear scale 116 and the linear sensor 115 when the virtual axis 160 is positioned at the centers of the lower light source

part 123 and the upper light source part 122 to determine whether or not the suction nozzle 201 is good. In this case, the CCD camera 106 preferably has a shutter function and drives the shutter to carry out the image-pickup when  
5 the virtual axis is positioned as above.

As described above, the transfer head part 210 has a plurality of suction nozzles 201 installed thereto in the present embodiment. The step moves to step 6 when at least one of the plurality of suction nozzles 201 is  
10 determined as defective, and then only defective nozzle(s) or all suction nozzles 201 are cleaned by the cleaning device 311. An example of a cleaning method will be described with reference to Figs. 11-13. The cleaning method corresponds to an example of a luminance reduction  
15 process carried out for the component hold face 140 of the suction nozzle 201.

After the transfer head part 210 is moved by the XY-robot 308 to the solvent bath part 901 of the cleaning device 311, only the defective nozzle(s) or all suction  
20 nozzles 201 are moved down by the operation of the driving parts 204 for ascent and descent, whereby the component hold faces 140 are soaked for approximately 10 seconds in the solvent 910 such as ethanol or isopropyl alcohol filled in the solvent bath part 901. The description of the  
25 succeeding process and thereafter will be directed to the

case of cleaning all suction nozzles 201. Subsequently, the suction nozzles 201 are moved by the XY-robot 308 to the solvent wiping part 902. After the movement, driving parts 204 for ascent and descent are driven to press down  
5 the component hold faces 140 by approximately 0.1mm onto the water-absorbing waste attached at the wiping part 902. Further in this state, driving parts 205 for rotation are driven to rotate the component hold faces 140 by approximately three times, thereby wiping off the solvent  
10 910. Finally, after the suction nozzles 201 are moved by the XY-robot 308 to the finishing part 903, the driving parts 204 for ascent and descent are driven to press the component hold faces 140 by approximately 0.1mm down onto the chamois leather attached at the finishing part 903.  
15 The driving parts 205 for rotation are driven in this state to rotate the component hold faces 140 by approximately three times as a finishing operation of the wiping.

After the above cleaning operation, the step proceeds to step 7, in which it is determined similar to  
20 the aforementioned step 5 whether or not each suction nozzle 201 is good. The step moves to step 8 when even one of the suction nozzles 201 is determined again as defective.

Meanwhile, when no defective nozzle is detected in step 7, the step moves to step 9, where the number of  
25 employment of each suction nozzle 201 is reset to 0. When

no defective nozzle is detected in step 5, similarly, the step moves to step 9 and then to step 10.

In step 8, the suction nozzle 201 determined again as defective is registered as a defective nozzle to be prevented from being used at the component mounting operation afterwards. At the same time, a warning is generated and the step moves to step 11 to exchange the nozzle by the nozzle changer 310.

In step 11, the transfer head 210 is moved by the XY-robot 308 to the suction nozzle changer 310, and only the defective nozzle(s) or all suction nozzles 201 are automatically detached and replaced by the suction nozzle changer 310 having spare nozzles 313. After finishing the step 11, step goes to step 9.

As described hereinabove, according to the present embodiment, whether or not the suction nozzle 201 is good can be automatically determined by measuring the luminance of the component hold face 140 of the suction nozzle 201 by the detecting device 100. Therefore, such trouble can be avoided that the light reflection by the component hold face 140 affects correct recognition of a state with the electronic component 312 held by the suction nozzle 201.

Moreover, according to the present embodiment, the detecting device 100 is installed at the transfer head

part 210 and, whether or not the suction nozzle 201 is good is determined by moving the camera stage 117 with the illuminating device 120, the light guide part 130 and the CCD camera 106 below the suction nozzle 201. Therefore, it becomes unnecessary to move the transfer head part 210 to, for example, a recognition device installed in the component mounting apparatus to carry out the image-pickup of the component hold posture at the suction nozzle. A time required for inspecting whether or not the suction nozzle 201 is good and for recognizing components can be shortened in comparison with the conventional art.

In the component mounting apparatus 300 of the present embodiment, the defective nozzle when detected by the detecting device 100 can be automatically cleaned by the cleaning device 311. The defective nozzle can be renewed accordingly. In addition, by providing the suction nozzle changer 310, the suction nozzle if determined as defective even after cleaned can be automatically replaced with a normal suction nozzle 201, enabling increasing an availability of the component mounting apparatus 300.

A modified example in relation to the detecting device 100 will be described below.

The setting value 652 is a value decided on the basis of the total luminance in the state with the electronic component 312 held at the suction nozzle 650 as

depicted above. How to decide the setting value 652 is not limited to this method, and the setting value can be decided, for example, by the following method. Concretely, a luminance of the component hold face 140 is measured with  
5 a fresh suction nozzle which is completely free from adhesion of contamination by the electronic component 312 to the component hold face 140 and at the same time, which has no peeling off of the coating. The luminance is set as a lower limit setting value. Theoretically, it is so  
10 considered that some adhesion of contamination or peeling off of the coating is present at the component hold face 140 of the suction nozzle if a luminance of the component hold face 140 measured exceeds the lower limit setting value. Therefore, by deciding a luminance value exceeding  
15 the lower limit setting value and smaller than the earlier-described setting value 652 as a threshold, unnecessary light reflection at the component hold face 140 can be detected with a higher accuracy as compared with the case when the setting value is decided to be the 100-gradation  
20 level.

As above, according to the method of measuring the luminance of the component hold face 140 at the suction nozzle 201 to be inspected, it is difficult in some cases to distinguish minute contamination or peeling off of the  
25 coating of the component hold face 140 which possibly leads

to wrong detection of the suction posture of the electronic component 312 from that of the component hold face 140 which never causes wrong detection of the suction posture. More specifically, as shown in Fig. 14, the method of detecting the luminance of the component hold face 140 cannot distinguish a case where a contamination or the like 603 of a size whereby the suction posture is possibly detected wrong is present at a non cover region 607 other than a region 601 covered with the electronic component 312 from a case where the contamination or the like 602 of a size similar to the size of the above contamination or the like 603 is present within the region 601 when the electronic component 312 is held at the component hold face 140. That is, since the contamination or the like 602 is covered and hidden by the electronic component 312 at the component recognition operation, adverse effects onto the detection of the suction posture are eliminated even if there is the contamination or the like 602 within the region 601. By the way, the contaminations or the like 602 and 603 are higher in the luminance than parts without contamination or the like at the component hold face 140. The same goes true for contaminations or the like 606 and 608 to be described below.

As indicated in Fig. 15, it is undistinguishable between a case where the countless minute contamination or

the like 606 which impossibility leads to wrong detection of the suction posture is spotted on the component hold face 140 and consequently a luminance resulting from the contamination or the like 606 is averaged to reach the same level as that of the contamination or the like 603 which causes wrong detection of the suction posture, and the case where the luminance is simply caused by the contamination or the like 603. In other words, such trouble is there that even the minute contamination or the like 606 not to lead to wrong detection of the suction posture is detected when it is tried to detect the contamination or the like 603 of the component hold face 140 which possibly causes wrong detection of the suction posture.

As above, the method of measuring the luminance of the entire component hold face 140 is preferred for the large contamination or the like 608 as shown in Fig. 16 which brings about a misjudgment that the electronic component is held by the suction nozzle 210 although the electronic component is actually not held by the suction nozzle because of the effect of light reflection caused by the contamination or the like of the component hold face 140. However, the method is not suitable to detect the contamination or the like 603 which possibly leads to wrong detection of the suction posture.

For solving this problem, a method to be

described below can be adopted as the modified example. Specifically, image-pickup information used in measuring the luminance is divided into a grid pattern as indicated in Fig. 17. The component hold face 140 having, e.g., a long side of 1.0mm and a short side of 0.5mm is divided to, for example, 50 sections. A threshold luminance value is set for each divided section 611 beforehand. A range of the region 601 is preliminarily stored in the nozzle data 405 in the controller 150. Since the region 601 is covered with the electronic component 312, the nozzle is not determined as a defective nozzle even if the luminance of not smaller than the threshold is detected at one or a plurality of sections 611 within the region 601.

On the other hand, the suction nozzle 201 is determined as a defective one when the luminance not smaller than the threshold is detected at one or a plurality of sections 611 in the non cover region 607 other than the region 601.

Only the minute contamination or the like 603 which affects the suction posture of the electronic component 312 can thus be correctly detected by dividing image-pickup data used in the luminance detection into a grid pattern thereby determining whether or not the suction nozzle is good. The suction nozzle can be prevented from being unnecessarily determined as defective one.

Both of the above methods of measuring the luminance of the whole component hold face 140 and of measuring the luminance of each section 611 after dividing the component hold face 140 into the grid pattern are to  
5 determine whether or not the suction nozzle 201 is good by measuring the luminance based on imaging information of the component hold face 140. However, how to determine whether or not the suction nozzle 201 is good is not limited to these methods. The determination may be carried out by not  
10 only measuring the luminance, but taking image-pickup information of the component hold face 140 into account. That is, if an image corresponding to a component is recognized within image-pickup information of the component hold face 140 at a time when image-pickup of the component  
15 hold face 140 without holding the electronic component 312 is carried out, the suction nozzle 201 may be determined as defective one even though the suction nozzle is determined as normal by the foregoing luminance measurement.

In this case, as the component corresponding to  
20 the image recognized within the image-pickup information of the component hold face 140, an image information 660 as shown in Fig. 18 of a minimum component having the smallest area among electronic components to be held by the suction nozzle 201 to be inspected is selected and stored into the  
25 storage part 152 of the controller 150 from the component

library 402 which is shape data of the object electronic components within the controller 150. Therefore, if image information 661 approximately equivalent to the image information 660 is confirmed in the image-pickup information when image-pickup of the component hold face 140 of the object suction nozzle 201 for holding the object electronic component is carried out in a state without the object electronic component being sucked, the object suction nozzle 201 can be determined as defective.

10           According to this method, the accuracy for determining whether the suction nozzle 201 is good or not can be improved more, and at the same time, the state without the component sucked can be prevented from being recognized wrong as if the component were sucked.

15           Furthermore, image information having, for instance, 90-10% of an area indicated by the stored image information 660 may be used as a criterion of the determination. For instance, if an area corresponding to 10% the area of the image information 660 is made the  
20           criterion, minute contamination and flaw can be detected with a higher accuracy, enabling avoiding wrong detection also in detecting the suction posture of the sucked electronic components 312.

          The method of utilizing sections 611 may be used  
25           alike in the above method. The foregoing various modified

examples can be combined appropriately and respective effects can be exerted accordingly.

Component mounting operation in the component mounting apparatus 300 with the above detecting device 100 will be briefly depicted hereinbelow.

The circuit board 301 is held by the circuit board hold part 303 through the loader part 302 and positioned in the XY-direction. In the meantime, the transfer head part 210 is moved by the XY-robot 308 in X and Y-directions to suck electronic components 312 by respective suction nozzles 201 from the first component supply part 305A, the second component supply part 305B or the third component supply part 305C. After the components are sucked and prior to the component mounting to the circuit board 301, the image-pickup of the suction posture of the electronic component 312 sucked by each suction nozzle 201 is carried out with the utilization of the detecting device 100 installed in the transfer head part 210. The image-pickup of the suction posture is carried out in this suction posture recognition operation similar to the above-described image-pickup operation for the component hold face 140 by the detecting device 100 while the camera stage 117 with the illuminating device 120, the light guide part 130 and the CCD camera 106 installed thereto is moved and positioned in the X-axis direction,

preferably without being stopped. However, the suction posture recognition operation can be carried out while the transfer head part 210 is moved towards the circuit board 301.

5           A position deviation amount of each of all electronic components 312 sucked by the suction nozzles 201 is detected on the basis of suction posture information of each of electronic components 312 which is sequentially taken and shape information of the component library 402  
10 included in the database part 401. The controller 150 calculates a rotation angle about the Z-axis to be corrected and movement amounts in X and Y-directions on the basis of mounting position information of the board data 404 included in the database part 401 and the above  
15 position deviation amount of the electronic component 312 in order to mount the electronic component 312 to a predetermined mounting position on the electronic circuit board 301. Each suction nozzle 201 is rotated about the Z-axis by the driving part 205 for rotation and is moved to  
20 the predetermined mounting position on the electronic circuit board 301 by the XY-robot 308 on the basis of the calculated rotation angle about the Z-axis to be corrected and the movement amounts in the X and Y-directions. The electronic components 312 held by the suction nozzles 201  
25 are sequentially mounted to the mounting position in this

manner.

Since the component mounting apparatus 300 has the detecting device 100 at the transfer head part 210, the image-pickup process of the suction postures of the electronic components 312 sucked by suction nozzles 201 can be sequentially carried out during the movement of the electronic components 312 to the circuit board 301 after being sucked. Therefore, the need of moving the transfer head part 210 to where a recognizer is disposed as in the conventional art is eliminated, so that the mounting cycle time can be shortened and the availability in the component mounting operation can be improved accordingly.

As above, while the controller 150 in the component mounting apparatus 300 controls the determination operation of good or not for suction nozzles 201 as its characteristic operation, the controller can also carry out an operation control to be described below to the transfer head part 210 in relation to the operation of the detecting device 100.

Specifically, since the electronic component mounting apparatus 300 has the detecting device 100 installed at the transfer head part 210, it becomes possible to carry out the image-pickup of the hold posture of each of electronic components 312 at a plurality of suction nozzles 201 included in the transfer head part 210

and sequentially mount the electronic component 312 which the image-pickup operation is finished to the circuit board 301.

Meanwhile, the illuminating device 120 and the  
5 light guide part 130 constituting the detecting device 100 and disposed at the bottom plate 118 are arranged to be below the electronic component 312 held by the suction nozzle 201, and moreover, the circuit board 301 is disposed to be lower than the bottom plate 118 as illustrated in  
10 Figs. 1 and 4. When the component mounting operation by suction nozzles 201 to the circuit board 301 is carried out, needless to say, the suction nozzle 201 moves toward the circuit board 301 while the bottom plate 118 is disposed to be deviated from the suction nozzle 201 which is to mount  
15 the component. Therefore, in the event of loss of synchronism between the bottom plate 118 and the suction nozzle 201 in their positional relation, for example, by some trouble at the detecting device driving part 110 which constitutes the detecting device 100, at the driving parts  
20 204 for ascent and descent in the transfer head part 210, or the like, the suction nozzle 201 which is to mount the component moves down in spite of the presence of the bottom plate 118 below the suction nozzle 201, whereby there is a possibility that the suction nozzle 201 interferes with the  
25 illuminating device 120 and the light guide part 130

disposed at the bottom plate 118. As factors for the bottom plate 118 and the suction nozzle 201 to be out of synchronization in the positional relation, there are conceivable that for example, (1) an output part of the detecting device driving motor 111 which constitutes the  
5 detecting device driving part 110 loosens, or stops during driving, (2) a trigger to the driving part 204 for ascending and descending the suction nozzle 201 malfunctions because of noise or the like, and the like.

10 For preventing the above interference, in a component mounting apparatus 350 as a modified example of the component mounting apparatus 300, such an arrangement can be adopted for the transfer head part 210 having the detecting device 100, which will be described more in  
15 detail below.

Fig. 19 indicates a transfer head part 211, a controller 155 and an interference preventing device 320 provided in the component mounting apparatus 350. The transfer head part 211 and the controller 155 correspond to  
20 one modified examples of the earlier described transfer head 210 and the controller 150 respectively. The other constituent parts than the transfer head part 211, the controller 155 and the interference preventing device 320 are the same as in the constitution of the above component  
25 mounting apparatus 300 and will be omitted from the

description here.

The transfer head part 211 has the suction nozzles 201, nozzle setting heads 202, head member 203, driving parts 204 for ascent and descent, driving parts 205  
5 for rotation, suction device 290, CCD camera 106, detecting device driving motor 111, bottom plate 118 and illuminating device 120 of the transfer head part 210. However, the bottom plate 118 has no light guide part 130 installed thereto, and the CCD camera 106 is installed just below the  
10 illuminating device 120. The linear sensor 115 and the linear scale 116 are also not installed in the transfer head part.

The interference preventing device 320 has the controller 155, a trigger signal generator 321,  
15 photosensors 322, a dog 323 fixed, for example, to the bottom plate 118, and a display device 324. The photosensor 322 and the dog 323 constitute an example functioning as the position detector. The trigger signal generator 321 generates a trigger signal for ascent and  
20 descent, particularly for descent of suction nozzle 201 to control descent or ascent timing of the suction nozzle 201, and sends the signal to the controller 155. Accordingly, the CCD camera 106 is moved synchronously with the downward movement of the suction nozzle 201. In a method for  
25 generating the trigger signal, the signal is generated at a

time point when the CCD camera 106 reaches a predetermined position or at a time point after a predetermined time has passed since a movement start of the CCD camera 106.

The photosensor 322 is arranged by the same  
5 number as that of suction nozzles 201 along the X-axis direction corresponding to an arrangement position of each suction nozzle 201 to detect shielding of light by the dog 323. A detection signal is sent to the controller 155. Since the photosensor 322 corresponding to the suction  
10 nozzle 201 opposite to the illuminating device 120 and the CCD camera 106 is thus shielded by the dog 323, at which position of the suction nozzles 201 where the CCD camera 106 is located can be detected correctly.

The controller 155 executes an algorithm for  
15 determining an instruction method to the driving parts 204 for ascent and descent on the basis of signals from the trigger signal generator 321 and the photosensor 322. The controller 155 is constituted of a microcomputer. A functional part for executing the algorithm in the  
20 controller 155 is made an interference prevention judging part 153. Fig. 20 is a flow chart showing an example of the algorithm in a process where there are present 8 suction nozzles 201 as shown in Fig. 19.

When the mounting operation starts, in step 31, a  
25 variable N expressing the number of the nozzle setting head

202 (referred to as a "head number" hereinafter) is initialized to 1. In step 32, the trigger signal for starting a descent of the suction nozzle 201 generally corresponding to the head number N is waited. At the mounting start time, the head number N is "1". After the trigger signal is inputted, a light shield state of each of the photosensors 322 is read in step 33 and it is checked in step 34 whether or not the photosensor 322 corresponding to the head number N detects light shielding by the dog 323. When the corresponding photosensor 322 does not detect the dog 323, the step moves to step 35 and the suction nozzle 201 of the head number N is lowered. On the other hand, when the light is shielded, the step shifts to step 36 because the CCD camera 106 would be interfered if the suction nozzle 201 of the head number N were moved down.

The above-described steps 34-36 show an embodiment in which an operation instruction to the driving parts 204 for ascent and descent is stopped when the detection result of the interference preventing device 320 is abnormal. However, how to prevent the interference is not limited to the above method, and a method, for example, of moving up and retreating the suction nozzle 201 to the outside of an interference range with the CCD camera 106, moving down the suction nozzle 201 to a height whereat the interference with the CCD camera 106 is avoided, or the

like may be used in step 35.

When the photosensor 322 corresponding to the suction nozzle 201 to be moved down detects the dog 323, a warning notice is displayed to the display device 324 in  
5 step 36. When the ascent and descent of the suction nozzle 201 is stopped by the driving part 204 for ascent and descent, a buzzer is sounded, the error is notified by communication, a lamp is turned on, or the like manner of warning notice may be used other than the above  
10 notification method. By this warning notification, for instance, the equipment operator can notice the abnormality of the equipment at an early stage and can promptly inspect and recover the equipment.

In step 37 after step 35, 1 is added to the head  
15 number N. In step 38, it is confirmed whether or not the head number is over 8. The step returns to step 32 unless the head number exceeds 8, whereby the steps are repeated to carry out a process of confirming before starting the  
20 downward movement of each of 8 suction nozzles 201 whether or not each suction nozzle 201 is allowed to move down. The detecting operation for interference prevention is terminated when the head number is over 8.

The above interference preventing device 320 can adopt a modification to be described hereinbelow.

25 In Fig. 21, there are used three photosensors A-C

and three dogs A-C for 8 nozzle setting heads 202. Dogs A-C are fixed to, for example, the bottom plate 118, and the photosensors A-C are arranged to be equal in position as illustrated. The dogs A-C are shaped in a light shield pattern to express the least significant bit of a binary number, higher-order bit one more than the dog A and higher-order bit one more than the dog B respectively. The photosensors A-C are arranged to correspond to the dogs A-C respectively, so that 3-bit detection information of 8 patterns in total is generated by the dogs A-C and photosensors A-C.

This arrangement can obtain the same effect as that using the interference preventing device 320. Moreover, in comparison with the interference preventing device 320, the number of photosensors can be reduced although the number of dogs increases, whereby a more simplified structure is enabled. It is made possible to detect the present position of the CCD camera 106 directly from the corresponding sensor by arranging one or more sensors for detecting the present position of the CCD camera 106 as in the above interference preventing device 320 and its modified example.

An arrangement shown in Fig. 22 may be adopted, in which the linear sensor 115 and the linear scale 116 are installed in place of the photosensors 322 and the dogs 323,

as in the transfer head part 210. The correct position of the CCD camera 106 can be detected by the linear sensor 115 and the linear scale 116.

Fig. 23 represents an example of a method for generating a camera position signal from waveforms of the linear sensor 115. The waveform A shows a rectangular wave generated from the linear sensor 115 by moving the CCD camera 106. Pulse signals at constant intervals are generated as indicated by the waveform B from the rectangular wave, and 8 camera position signals in waveforms C1-C8 corresponding to 8 nozzle setting heads 202 are generated by counting the pulse signals. The camera position signals of this example are related to the case in which a camera movement direction is limited to one way along the X-axis direction, indicating that the suction nozzles 201 are allowed to move down when the waveform C1 and the like are on, that is, in a segment where the waveforms rise. After the CCD camera 106 passes the position corresponding to each nozzle setting head 202, the signal is kept ON at all times, thereby allowing the suction nozzles 201 to move down.

An algorithm for determining the instruction method to the driving parts 204 for ascent and descent which is executed by the controller 155 in the case of using the linear sensor 115 and the linear scale 116 will

be described hereinafter.

Fig. 24 shows a flow chart of an example of the algorithm of a process in which there are 8 nozzle setting heads 202 similar to the foregoing example. Steps 41-43 and 45-48 shown in Fig. 24 are the same as steps 31-33 and 35-38 in Fig. 20, and only step 44 is different. Step 44 alone will be described here. In step 44, it is confirmed before each suction nozzle 201 is moved down whether or not the camera position signal corresponding to the suction nozzle 201 to be moved down is ON. It is decided that the suction nozzle 201 can be moved down only when the camera position signal is ON.

In the constitution using the linear sensor 115 and the linear scale 116 as in Fig. 22, since the correct position of the CCD camera 106 can be detected, the signal can be used as a signal for controlling a shutter timing for the CCD camera 106 to carry out the image-pickup of the electronic component 312 sucked by each suction nozzle 201. The waveform B shown in Fig. 23 is used as the shutter signal in this case. This constitution enables the image-pickup of the suction nozzle 201 when the suction nozzle 201 to be imaged and the CCD camera 106 are become in the correct positional relation, for example, when the virtual axis 160 of the suction nozzle 201 is brought to the center of the CCD camera 106.

Supposed that the position of the nozzle setting heads 202 is changed in the X-axis direction, it is necessary to change the position of the sensors in the constitution using the photosensors and the like as in Figs. 5 19 and 21. However, the need is eliminated in the case where the linear sensor 115 and the linear scale 116 are used, and the present position of the CCD camera 106 can be detected directly.

For the above component mounting apparatus 350, 10 the constitution of the transfer head part 210 in Fig. 4 in the component mounting apparatus 300 can be employed in place of the transfer head part 211.

In the component mounting apparatus 350 alike, after the component mounting operation is carried out by a set number of times before a next component mounting 15 operation is carried out, the determination operation of good or not of the suction nozzles 201 which is discussed in relation to the component mounting apparatus 300 is carried out. However, it is possible in the component 20 mounting apparatus 350 to carry out only the above-described interference prevention operation between the suction nozzles 201 and the CCD camera 106 without executing the determination operation of good or not of the suction nozzles 201.

25 Although the transfer head part 210 is installed

at the XY-robot 308 in each of the above embodiments, any form can be adopted so long as the circuit board 301 and the transfer head part 210 are configured to move relatively to each other, for example, the transfer head  
5 part 210 is moved in the Y-axis direction and the circuit board 301 is moved in the X-axis direction.

In the above explanation, the component mounting apparatus 350 is explained as the modified example of the component mounting apparatus 300. However the component  
10 mounting apparatus 350 can work without working the operation of the detecting device 100.

Although the present invention has been fully described in connection with the preferred embodiments thereof with reference to the accompanying drawings, it is  
15 to be noted that various changes and modifications are apparent to those skilled in the art. Such changes and modifications are to be understood as included within the scope of the present invention as defined by the appended claims unless they depart therefrom.

## CLAIMS

1. A device for detecting whether or not a component holder is good, which comprises:

5 an illuminating device (120) for emitting light to the component holder (201) having a component hold face (140) with an area not smaller than a light reflection face (141) of a component (312);

10 an image-pickup device (106) for carrying out an image-pickup of the component hold face illuminated by the illumination of the illuminating device; and

15 a controller (150) for determining whether or not the component holder is good on a basis of a luminance of the component hold face in image-pickup information of the component hold face supplied from the image-pickup device.

2. The detecting device according to Claim 1, wherein the controller has a setting value (652) set on a basis of a total luminance by reflection from the component and the component hold face when the illuminating device emits light in a state with the component being held at the component hold face, so that determines that the component holder is defective when the luminance at the component hold face in a state without the component being held is not smaller than the setting value.

25 3. The detecting device according to Claim 2,

wherein the controller has region information related to a plurality of sections (611) obtained by dividing the component hold face and determines whether or not a luminance at each section is not smaller than the setting  
5 value.

4. The detecting device according to Claim 2, wherein, when the luminance is smaller than the setting value, the controller determines the component holder as defective if an image corresponding to the component is  
10 recognized within imaging information of the component hold face supplied from the image-pickup device.

5. The detecting device according to Claim 4, wherein the controller has information related to the image of the component recognized within the imaging information  
15 of the component hold face, the information related to the image being made image information of a size not larger than a minimum component to be held by the component holder.

6. The detecting device according to Claim 1, wherein the illuminating device emits light to the  
20 component holder by an amount of light for inspection which exceeds a maximum amount of light at a time when the illuminating device emits light to the component and the component hold face in a state with the component being held at the component hold face.

25 7. A method for detecting whether or not a

component holder is good, which comprises:

emitting light to a component holder (201) having a component hold face (140) of an area not smaller than a light reflection face (141) of a component (312);

5 carrying out of image-pickup of the illuminated component hold face; and

determining whether or not the component holder is good on a basis of a luminance of the component hold face in image-pickup information of the component hold face.

10 8. The detecting method according to Claim 7, wherein, when a setting value (652) is set on a basis of a total luminance by reflection from the component and the component hold face at a time when light is emitted to the component holder in a state with the component being held  
15 at the component hold face, the component holder is determined as defective when the luminance at the component hold face in a state without the component being held is not smaller than the setting value.

9. The detecting method according to Claim 8,  
20 wherein, when there is region information related to a plurality of sections (611) obtained by dividing the component hold face, it is determined whether or not the luminance is not smaller than the setting value for each section.

25 10. The detecting method according to Claim 8,

wherein, when the luminance is smaller than the setting value, the component holder is determined as defective when an image corresponding to the component is recognized within imaging information of the component hold face.

5           11.           The detecting method according to Claim 10, wherein information related to the image of the component recognized within the imaging information of the component hold face is made image information of a size not larger than a minimum component to be held by the component holder.

10           12.           The detecting method according to Claim 7, wherein light is emitted to the component holder by an amount of light for inspection which exceeds a maximum amount of light at a time when the component and the component hold face are illuminated in a state with the  
15 component being held at the component hold face.

13.           A component mounting apparatus which comprises:

                  a device (100) for detecting whether or not a component holder (201) is good which includes: an  
20 illuminating device (120) for emitting light to the component holder having a component hold face (140) of an area not smaller than a light reflection face (141) of a component (312), an image-pickup device (106) for carrying out image-pickup of the component hold face illuminated by  
25 the illuminating device, and a controller (150) for

determining whether or not the component holder is good on a basis of a luminance of the component hold face in imaging information of the component hold face supplied from the image-pickup device;

5 a component supply device (305) for supplying a component to be held by the component holder; and

a component load and transfer device (200) with the component holder for holding the component from the component supply device with the component holder and  
10 mounting the held component onto a circuit board (301).

14. The component mounting apparatus according to Claim 13, wherein the component load and transfer device has a detecting device supporter (117) with a plurality of the component holders arranged in an array for holding the  
15 illuminating device and the image-pickup device disposed opposite to the component hold faces of the component holders and included in the detecting device, and a drive unit (111, 112, 115 and 116) for moving the detecting  
device supporter in relation to the component holders along  
20 an arrangement direction of the component holders.

15. The component mounting apparatus according to Claim 13, which further comprises a cleaning device (311) for cleaning a component hold face of a defective component holder determined as defective by the detecting  
25 device.

16. The component mounting apparatus according to Claim 13, which further comprises a holder replacement device (310) for separating and holding a defective holder determined as defective by the detecting device from the component load and transfer device, and holding a spare component holder (313) for the component holder installed in the component load and transfer device.

17. The component mounting apparatus according to Claim 14, wherein the component load and transfer device further has driving parts for ascent and descent (204) installed corresponding to respective component holders for moving the component holders up and down, and a position detector (115, 116, 322 and 323) for detecting a position of the image-pickup device moved by the drive unit along the arrangement direction of the component holders,

the component mounting apparatus further having a trigger signal generator (321) for generating a trigger signal for moving down the component holders to the driving parts for ascent and descent,

so that the controller controls the driving parts for ascent and descent on a basis of the position of the image-pickup device by the position detector when the trigger signal is generated by the trigger signal generator.

18. The component mounting apparatus according to Claim 17, wherein the position detector has sensors for

detecting the position of the image-pickup device.

19. The component mounting apparatus according to Claim 17, wherein the position detector has a linear sensor (115) and a linear scale (116) arranged along the arrangement direction.

20. The component mounting apparatus according to Claim 19, wherein the controller uses an output signal of the linear sensor to control a timing of the image-pickup by the image-pickup device.

21. The component mounting apparatus according to Claim 17, wherein the controller stops an operation instruction to the driving parts for ascent and descent when it is determined on a basis of an output from the position detector that the image-pickup device and the component holder interfere with each other.

22. The component mounting apparatus according to Claim 21, wherein the controller carries out warning notification when generating the operation instruction for the stop.

23. A component mounting method, in which whether or not a component holder (201) is good is determined by carrying out a detecting method of determining whether or not the component holder is good on a basis of a luminance of a component hold face (140) in imaging information of the component hold face by emitting

light to the component holder having the component hold face of an area not smaller than a light reflection face (141) of a component (312) and carrying out image-pickup of the illuminated component hold face after a component mounting operation of holding a component (312) by the component holder (201) and mounting the component to a circuit board (301) is carried out by a set number of times before a next component mounting operation is started.

24. The component mounting method according to Claim 23, wherein a luminance reduction process is carried out to a component hold face of a defective component holder when the component holder is determined as defective by the detecting method.

25. The component mounting method according to Claim 23, wherein, in the component mounting operation when the components (312) are sucked to the component holders (201) by independently moving up and down a plurality of the component holders arranged linearly to each other, carried out the image-pickup of the components sucked by the component holders by an image-pickup device (106) by moving the image-pickup device from below the component holders along an arrangement direction of the component holders, and mounted to the circuit board (301) after the image-pickup,

25 a position of the image-pickup device with moving

is detected, so that the downward movement of the component holders is controlled on a basis of the detected position.



Fig. 2

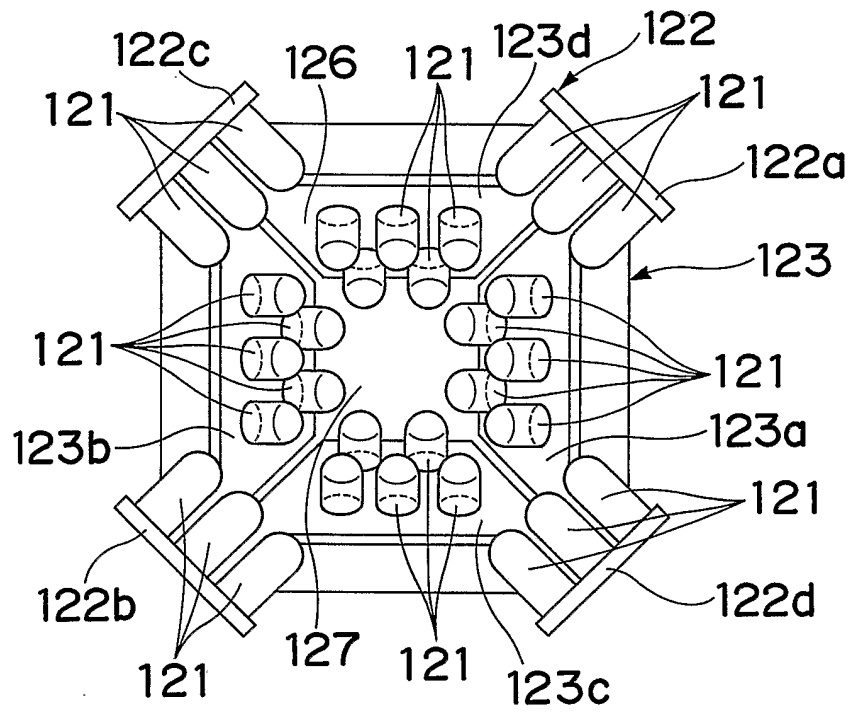

Fig. 3

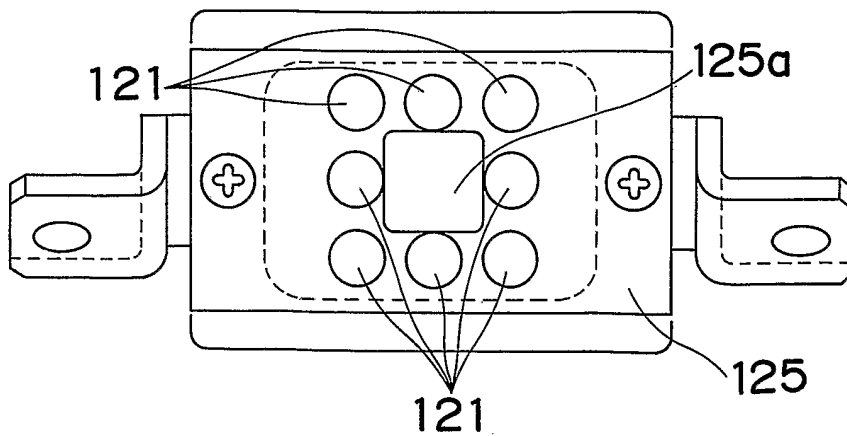

Fig. 4

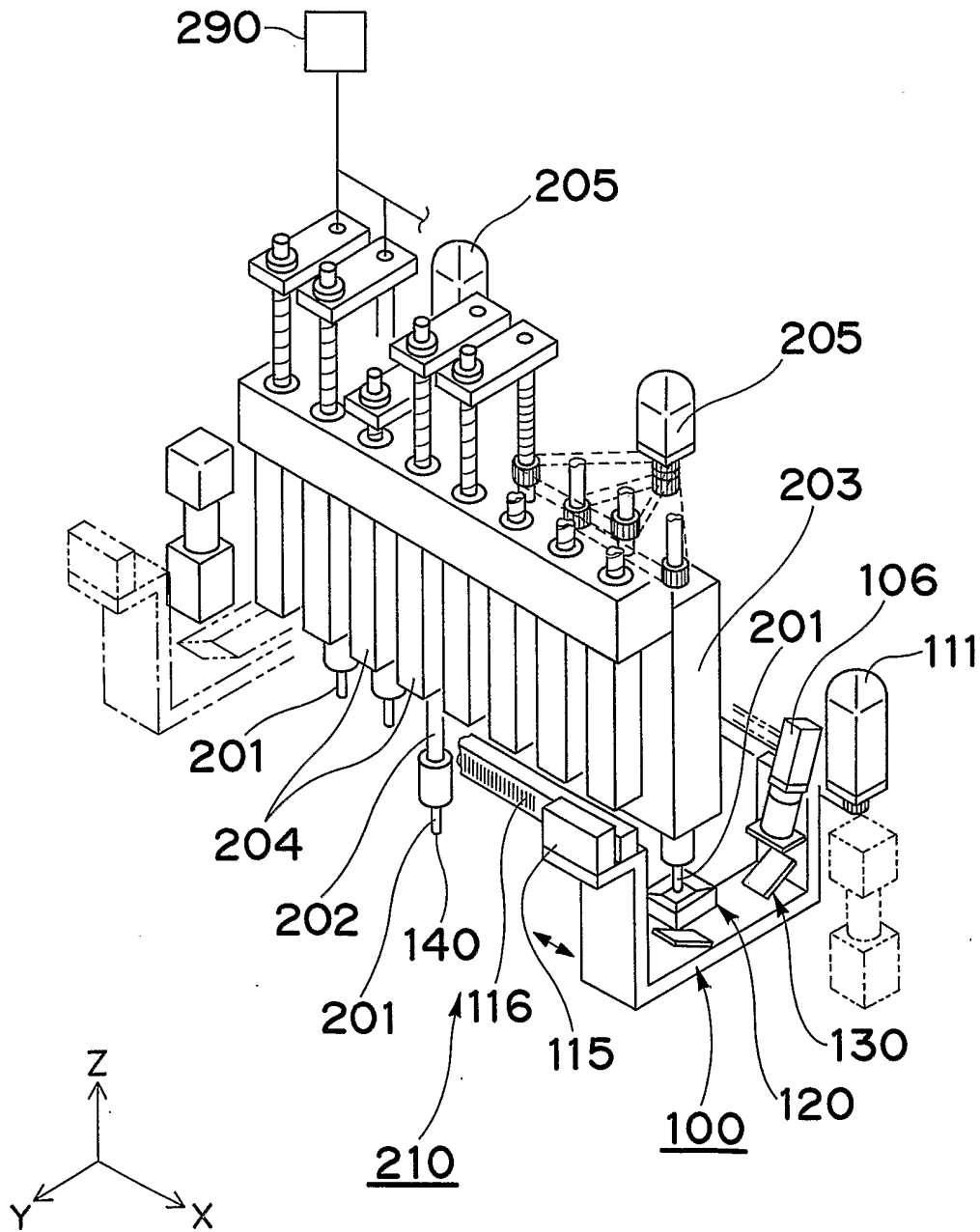

Fig. 5

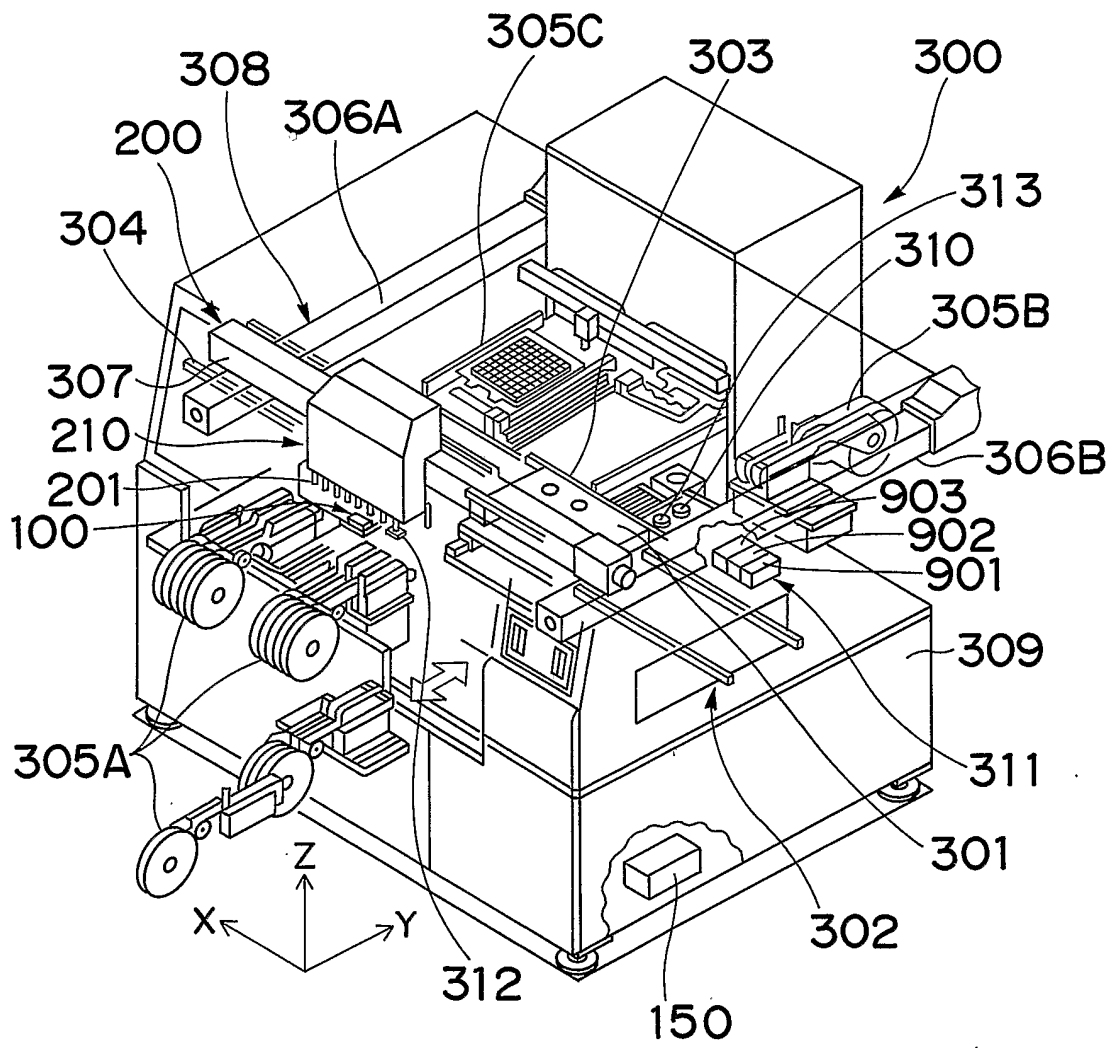

Fig.6

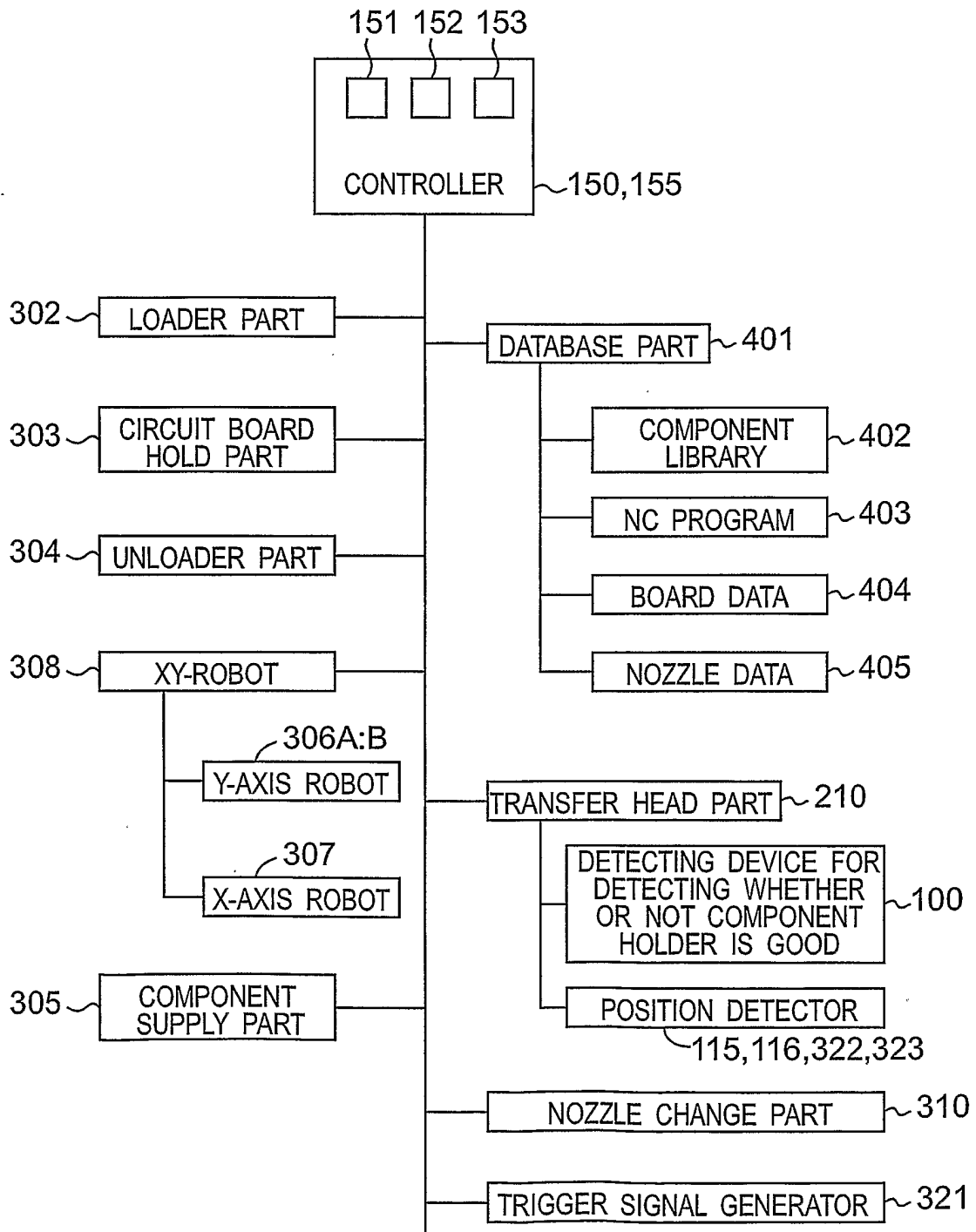

Fig.7

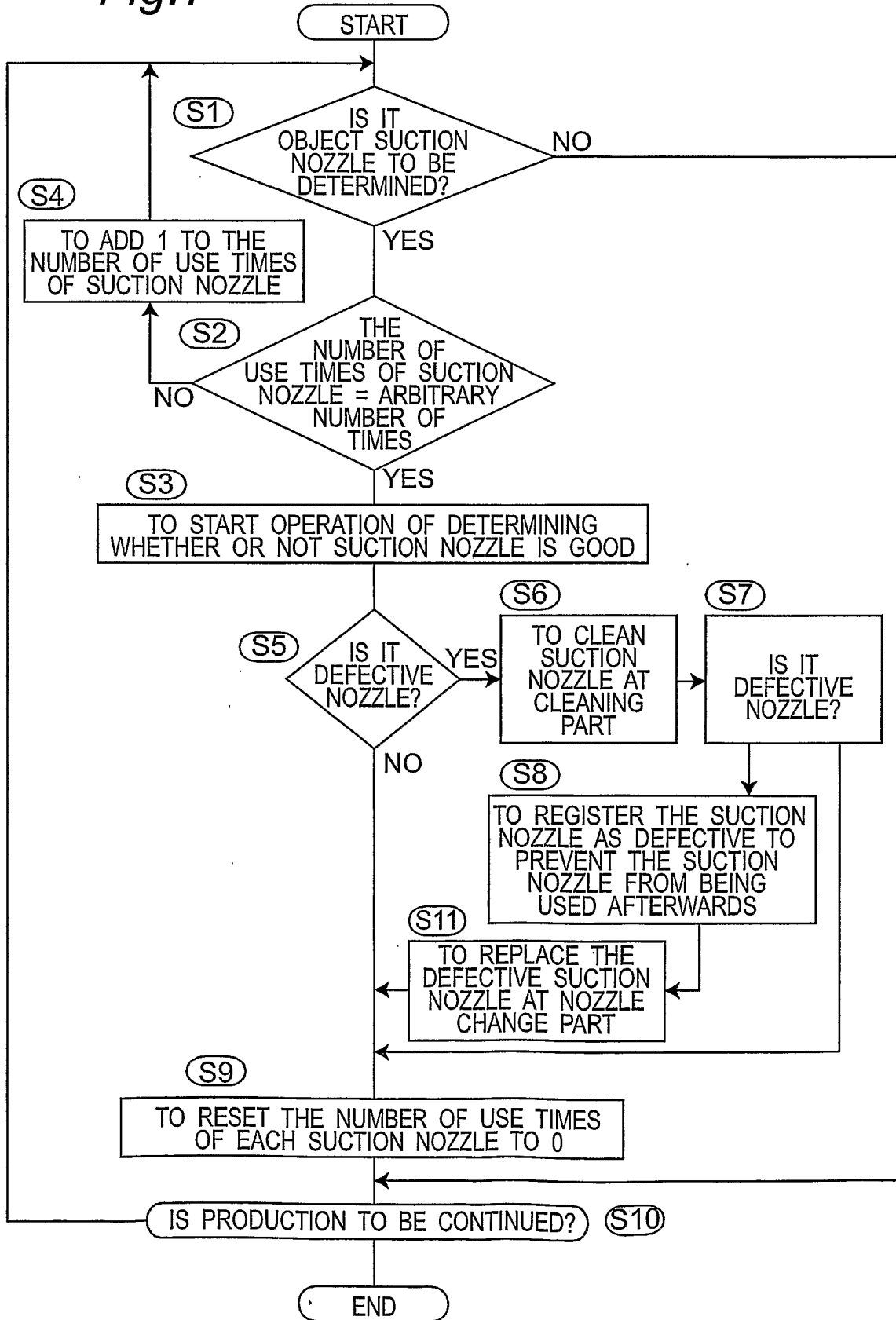

Fig. 8

NOZZLE	OBJECT COMPONENT	NOZZLE GLITTER TO BE CHECKED
SX NOZZLE	0.6mm×0.5C,R	○
SA NOZZLE	1.0mm×0.5C,R SS MINI TRANSISTOR	○
S NOZZLE	1.6mm×0.8 2.0mm×1.25C,R S MINI TRANSISTOR (2mm×2.1)	○
M NOZZLE	TANTALUM CAPACITOR (6mm×3.5) TRIMMING POTENTIOMETER (4.5mm×3.8) ALUMINA ELECTROLYTIC CAPACITOR (4.3mm×4.3)	○
L NOZZLE	SOP (DIMENSIONS NOT SMALLER THAN 7.6mm) QFP (DIMENSIONS NOT SMALLER THAN 12mm)	×

Fig. 9

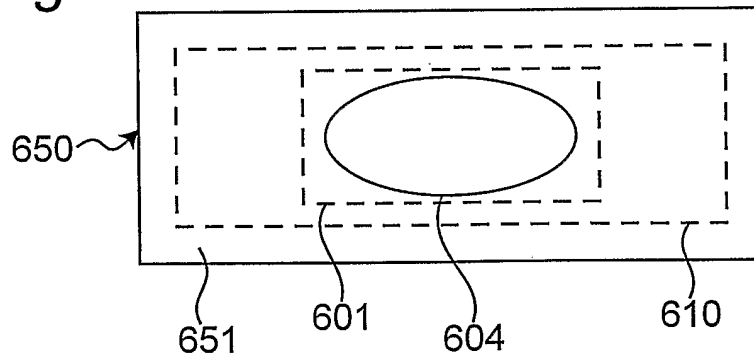
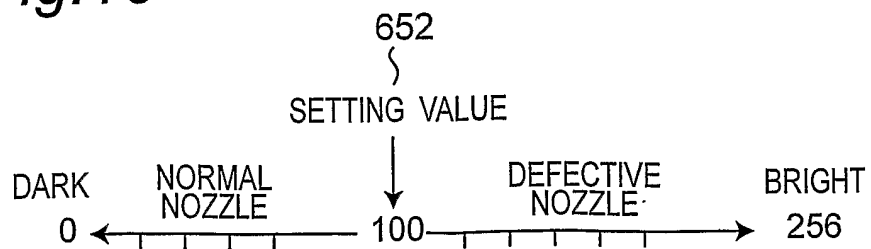
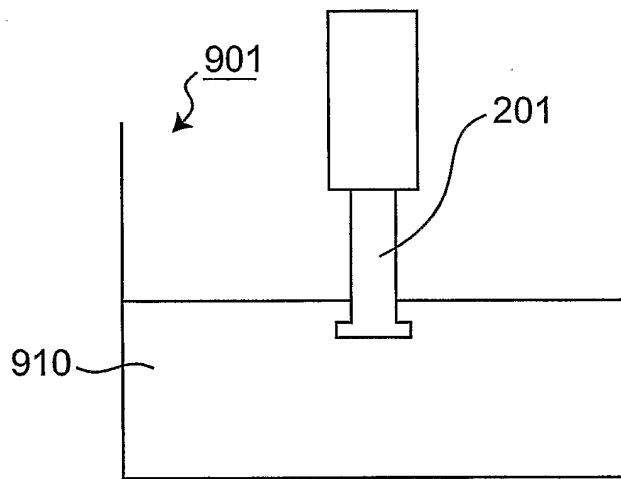

Fig. 10



*Fig. 11*



*Fig. 12*

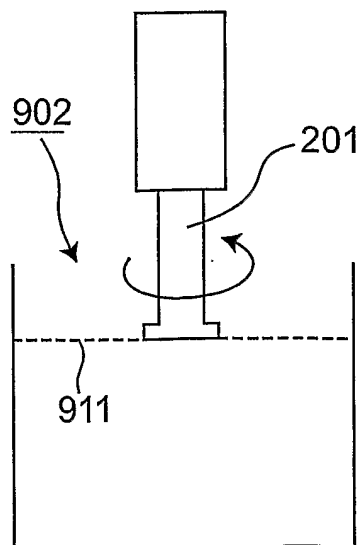

Fig.13

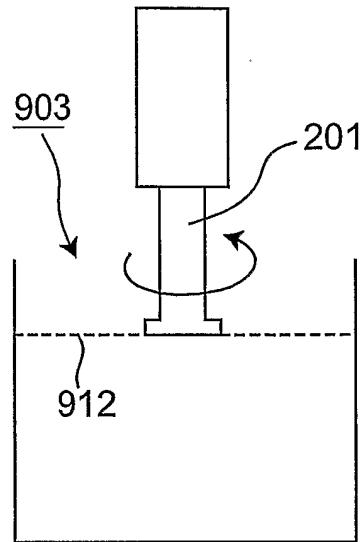

Fig.14

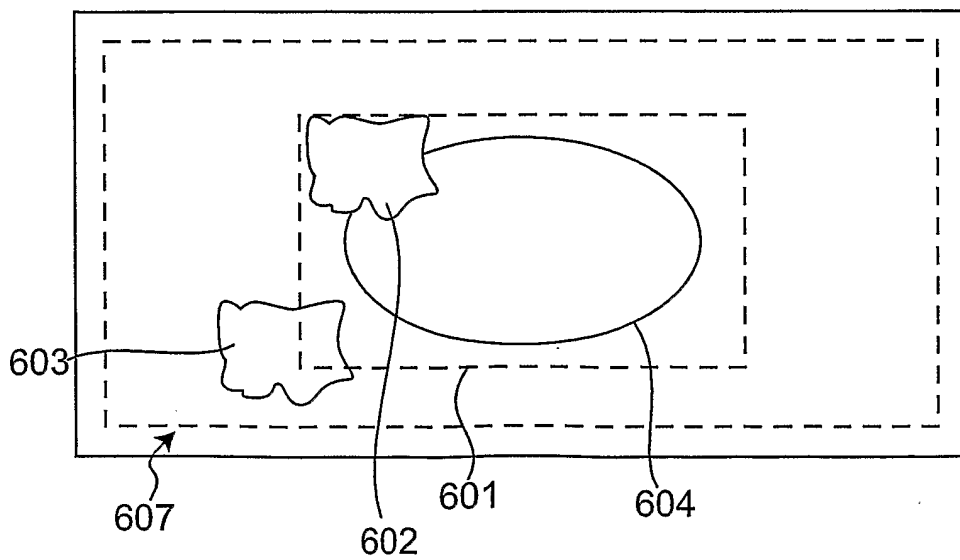

Fig. 15

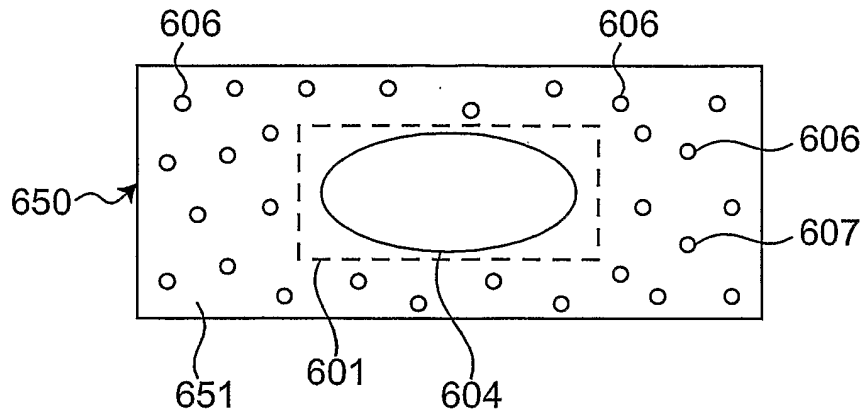

Fig. 16

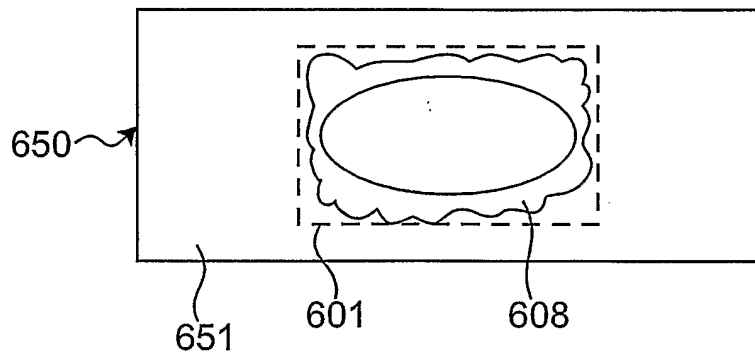
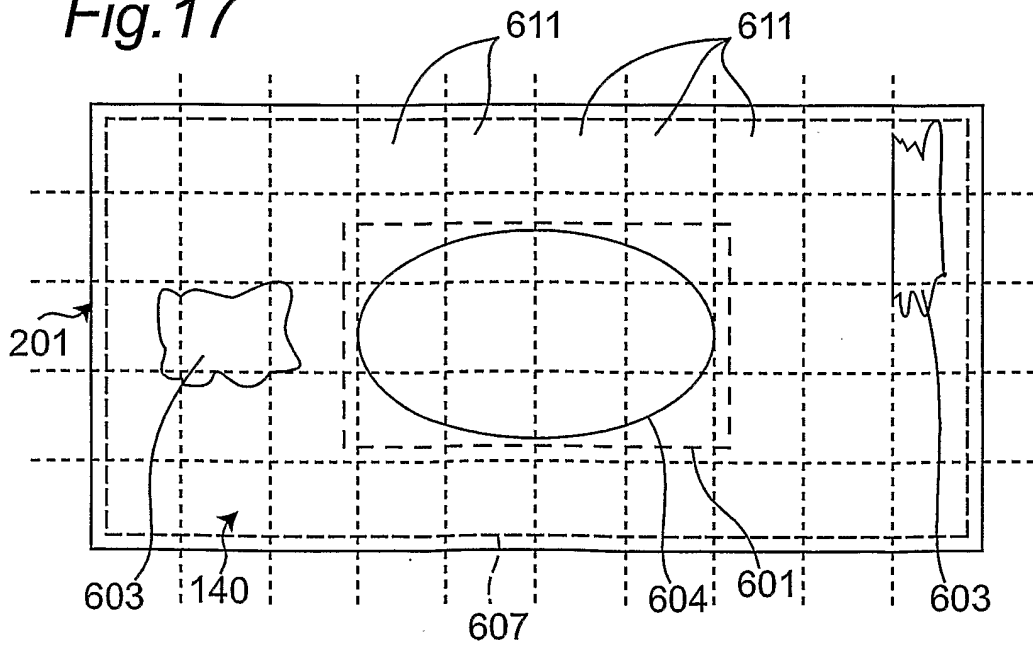

Fig. 17



*Fig. 18*

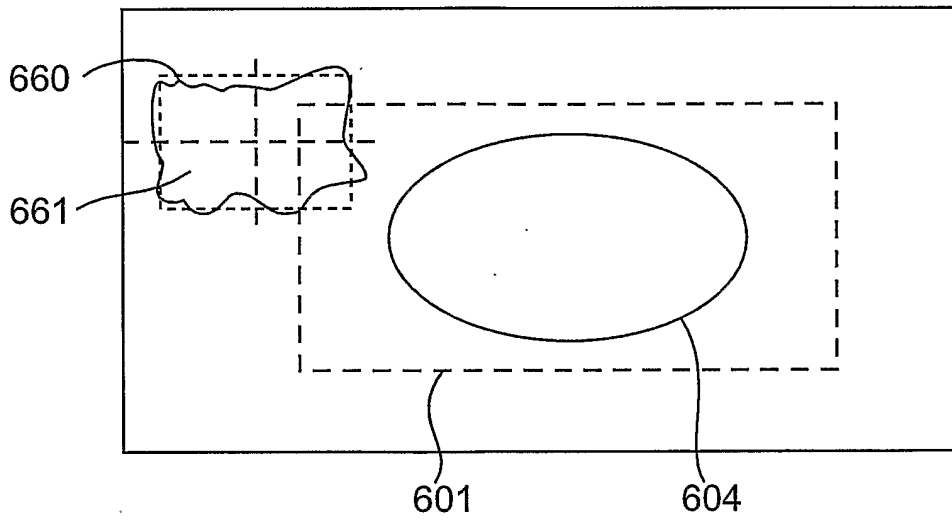

Fig. 19

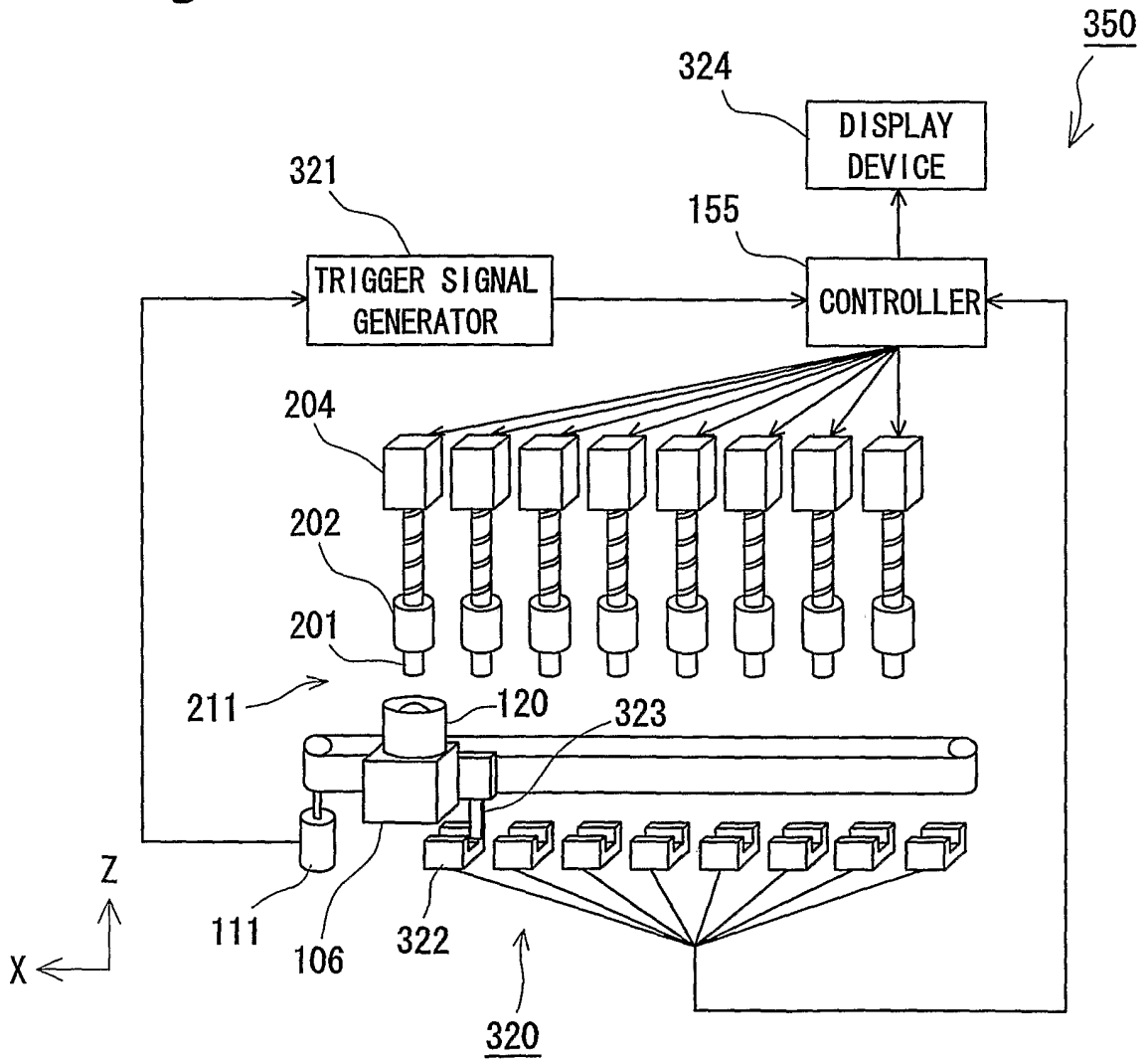
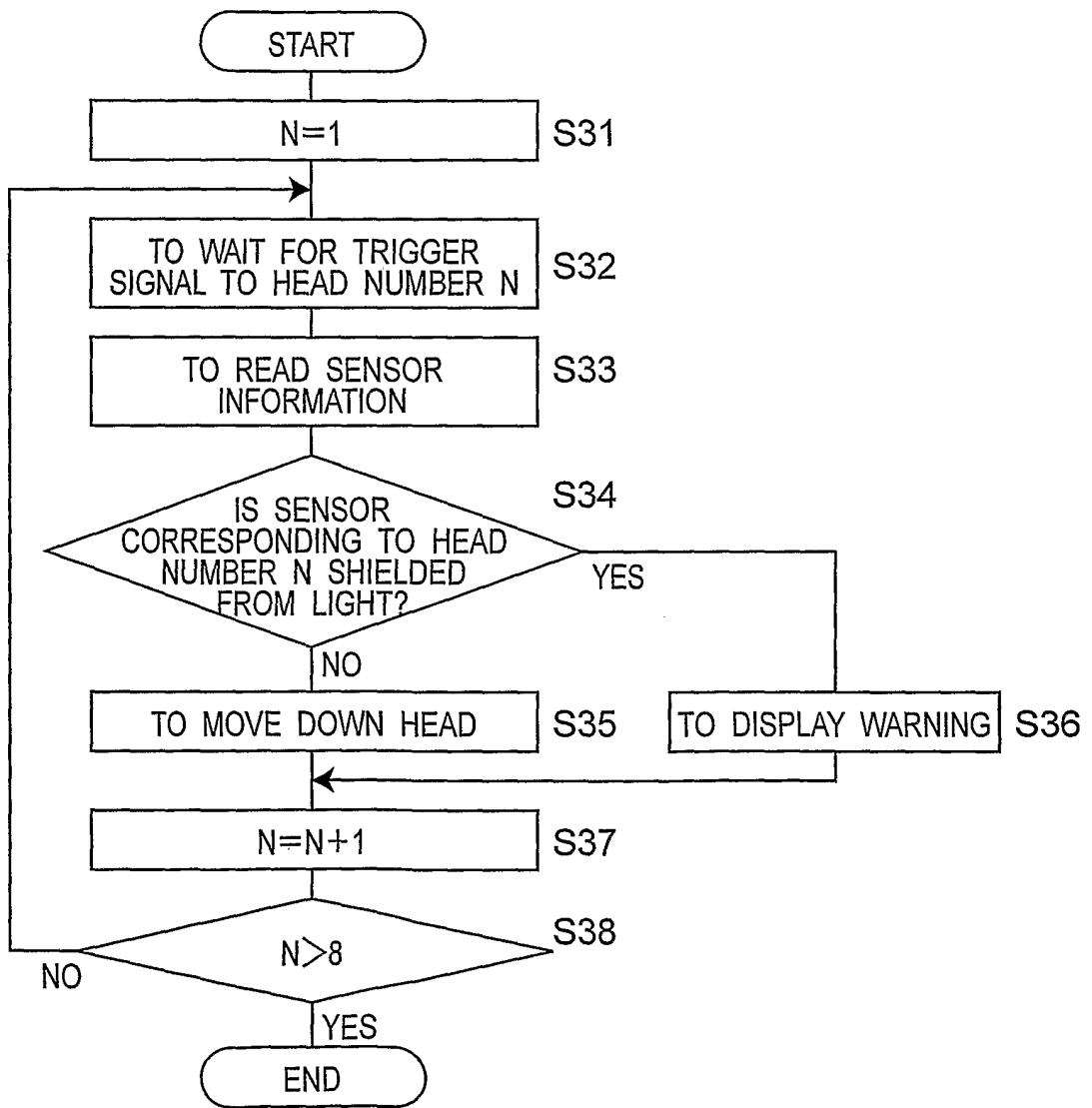

Fig.20



*Fig. 21*

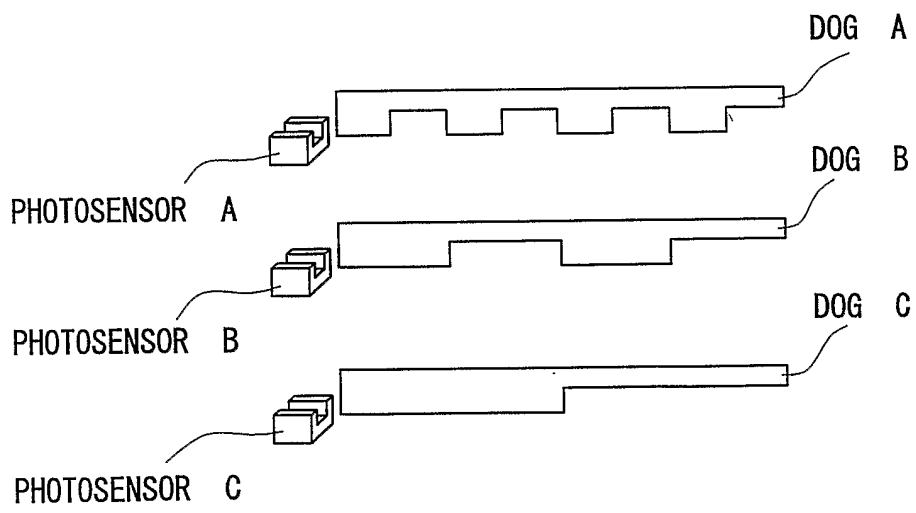
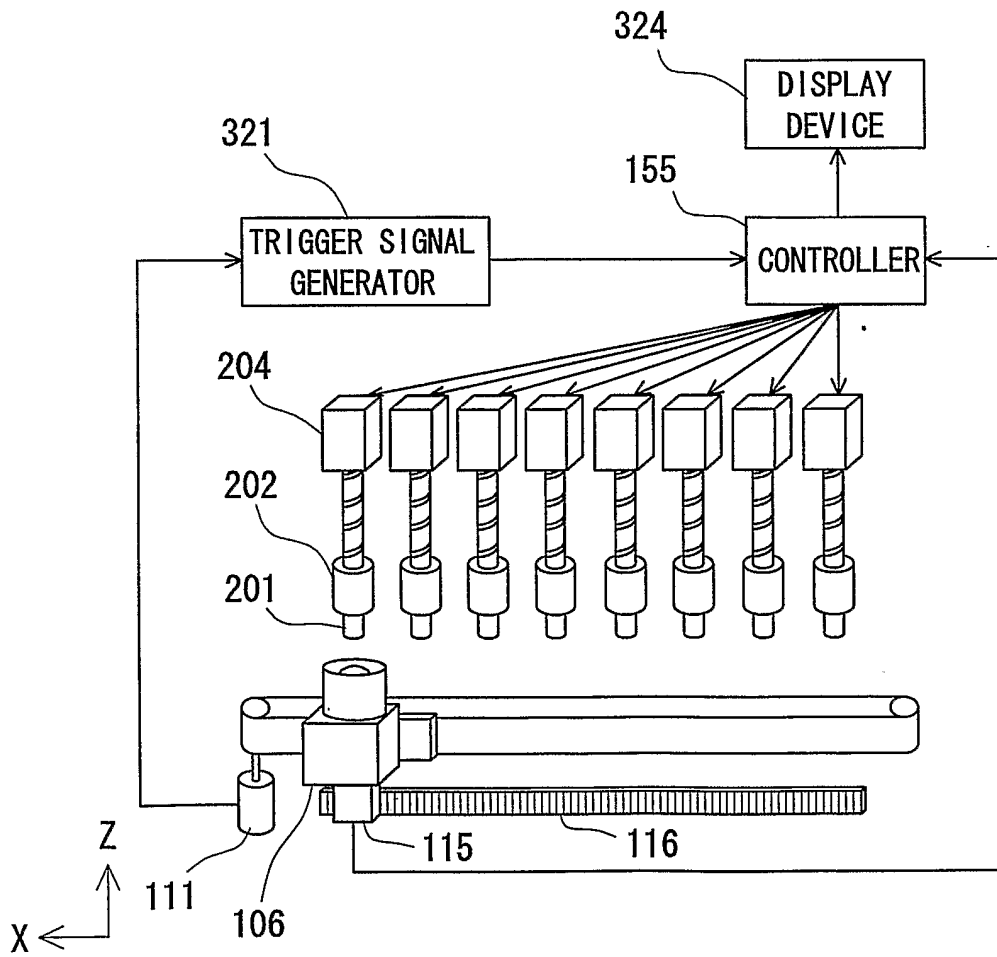

Fig. 22



*Fig. 23*

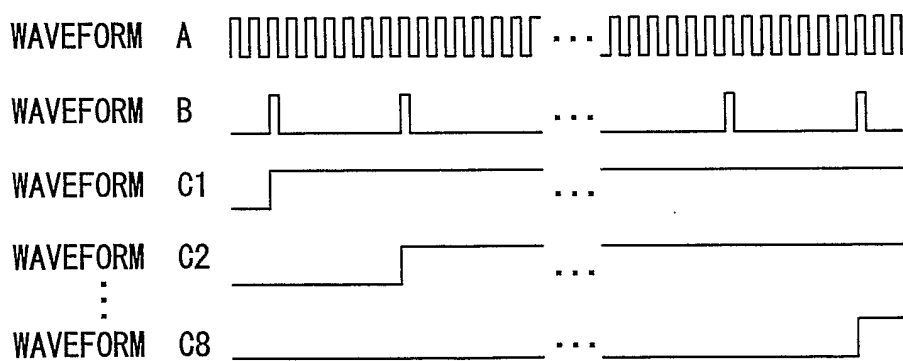
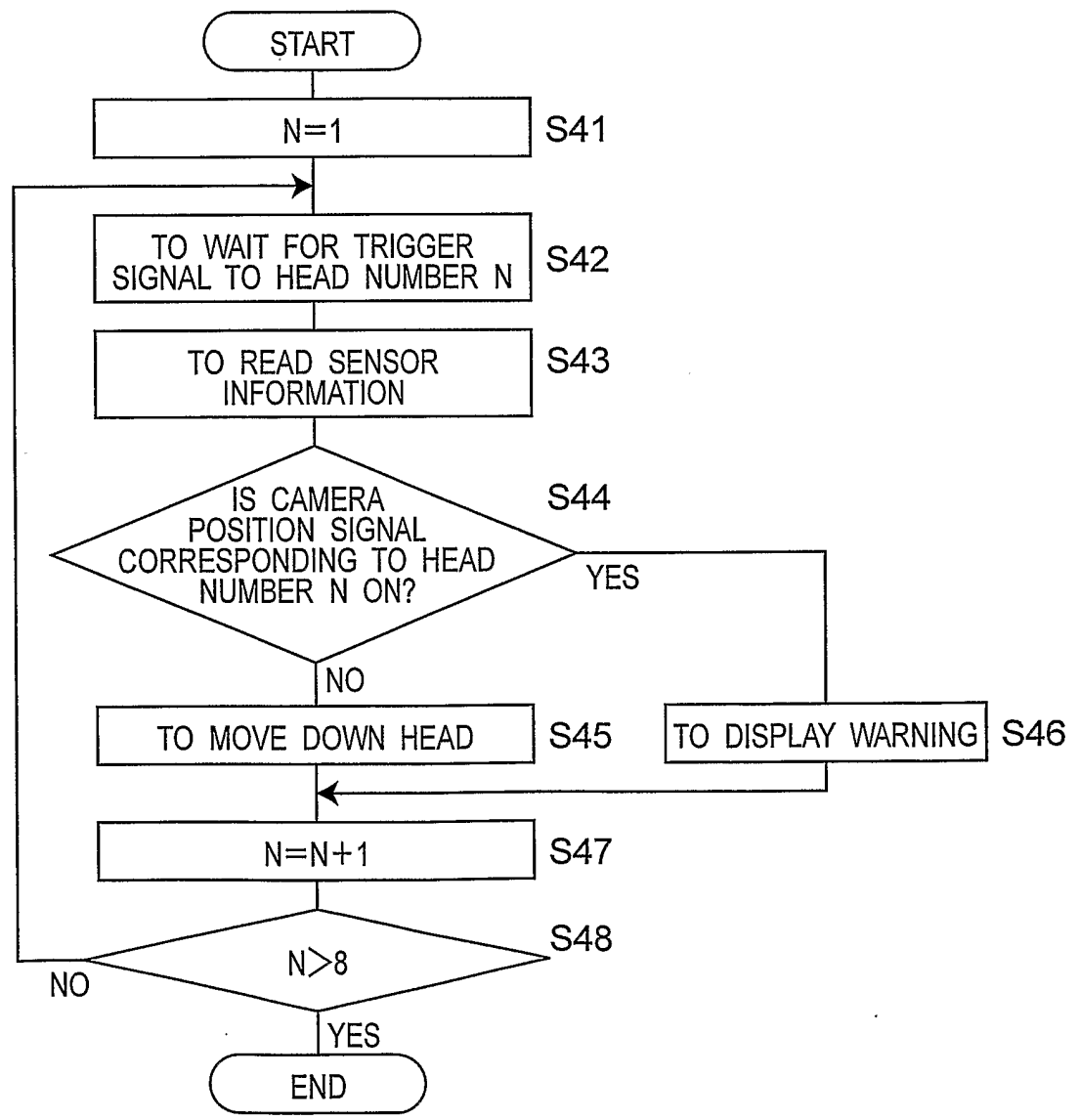
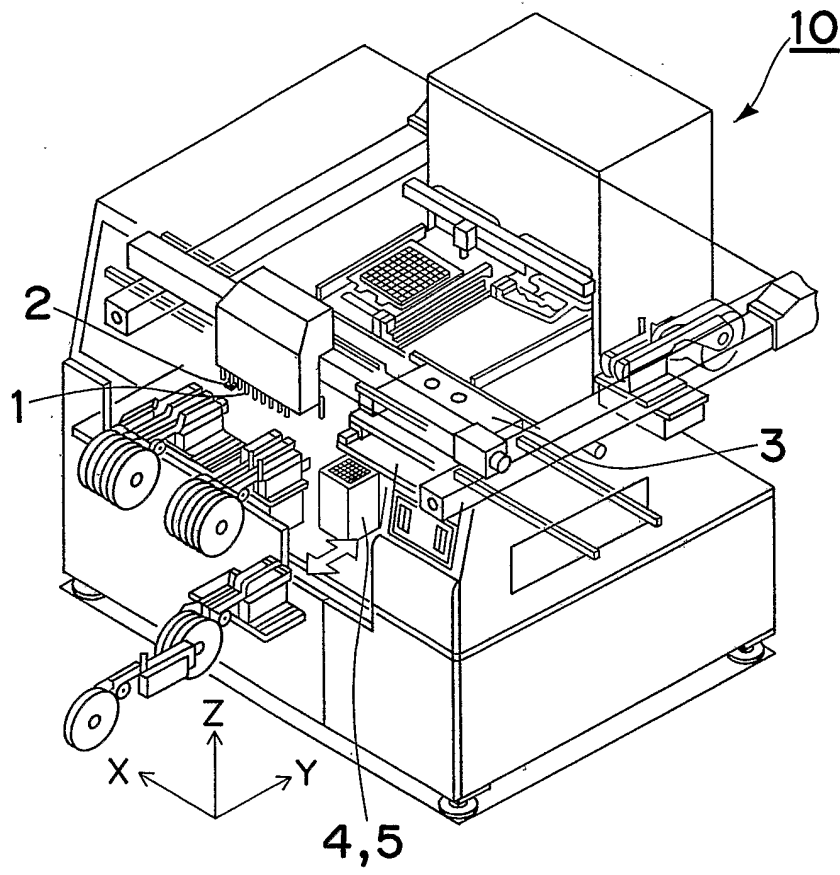

Fig.24



*Fig.25*



# INTERNATIONAL SEARCH REPORT

Intern~~ational~~ Application No

PCT/JP 03/10044

**A. CLASSIFICATION OF SUBJECT MATTER**  
 IPC 7 H05K13/08 H05K13/04

According to International Patent Classification (IPC) or to both national classification and IPC

**B. FIELDS SEARCHED**  
 Minimum documentation searched (classification system followed by classification symbols)  
 IPC 7 H05K

Documentation searched other than minimum documentation to the extent that such documents are included in the fields searched

Electronic data base consulted during the international search (name of data base and, where practical, search terms used)  
 EPO-Internal, WPI Data, PAJ

**C. DOCUMENTS CONSIDERED TO BE RELEVANT**

Category °	Citation of document, with indication, where appropriate, of the relevant passages	Relevant to claim No.
A	US 4 745 295 A (SENO ET AL.) 17 May 1988 (1988-05-17) the whole document ---	1,2,7, 13,23
A	US 5 764 874 A (WHITE) 9 June 1998 (1998-06-09) the whole document ---	1,7,13, 23
A	US 6 385 507 B1 (BUIJTELS) 7 May 2002 (2002-05-07) the whole document ---	1
A	JP 10 163690 A (TENRYU TECHNIC KK) 19 June 1998 (1998-06-19) abstract -----	1

Further documents are listed in the continuation of box C.       Patent family members are listed in annex.

° Special categories of cited documents :

<p>"A" document defining the general state of the art which is not considered to be of particular relevance</p> <p>"E" earlier document but published on or after the international filing date</p> <p>"L" document which may throw doubts on priority claim(s) or which is cited to establish the publication date of another citation or other special reason (as specified)</p> <p>"O" document referring to an oral disclosure, use, exhibition or other means</p> <p>"P" document published prior to the international filing date but later than the priority date claimed</p>	<p>"T" later document published after the international filing date or priority date and not in conflict with the application but cited to understand the principle or theory underlying the invention</p> <p>"X" document of particular relevance; the claimed invention cannot be considered novel or cannot be considered to involve an inventive step when the document is taken alone</p> <p>"Y" document of particular relevance; the claimed invention cannot be considered to involve an inventive step when the document is combined with one or more other such documents, such combination being obvious to a person skilled in the art.</p> <p>"&amp;" document member of the same patent family</p>
--	--

Date of the actual completion of the international search  <b>28 November 2003</b>	Date of mailing of the international search report  <b>10/12/2003</b>
--	---

Name and mailing address of the ISA European Patent Office, P.B. 5818 Patentlaan 2 NL - 2280 HV Rijswijk Tel. (+31-70) 340-2040, Tx. 31 651 epo nl, Fax: (+31-70) 340-3016	Authorized officer  <b>Bolder, G</b>
--	--

# INTERNATIONAL SEARCH REPORT

Information on patent family members

International Application No

PCT/JP 03/10044

Patent document cited in search report	Publication date	Patent family member(s)	Publication date
US 4745295	A	17-05-1988 JP 1685919 C	11-08-1992
		JP 3045919 B	12-07-1991
		JP 61289692 A	19-12-1986
US 5764874	A	09-06-1998 US 5604550 A	18-02-1997
		US 5539485 A	23-07-1996
		US 5842060 A	24-11-1998
		US 5761540 A	02-06-1998
US 6385507	B1	07-05-2002 WO 0101118 A1	04-01-2001
		EP 1108208 A1	20-06-2001
		JP 2003503701 T	28-01-2003
JP 10163690	A	19-06-1998 NONE	