



(86) Date de dépôt PCT/PCT Filing Date: 2008/09/01
 (87) Date publication PCT/PCT Publication Date: 2009/03/05
 (85) Entrée phase nationale/National Entry: 2010/02/10
 (86) N° demande PCT/PCT Application No.: NO 2008/000309
 (87) N° publication PCT/PCT Publication No.: 2009/028957
 (30) Priorité/Priority: 2007/08/30 (US60/968,899)

(51) Cl.Int./Int.Cl. *F01N 3/025* (2006.01),
F01N 3/08 (2006.01)
 (71) Demandeur/Applicant:
ENERGY CONVERSION TECHNOLOGY AS, NO
 (72) Inventeurs/Inventors:
LUCKA, KLAUS, DE;
KOEHNE, STEPHAN, DE
 (74) Agent: FETHERSTONHAUGH & CO.

(54) Titre : ENSEMBLE FILTRE A PARTICULES ET PROCEDE DE NETTOYAGE DUDIT FILTRE
 (54) Title: PARTICLE FILTER ASSEMBLY AND METHOD FOR CLEANING A PARTICLE FILTER

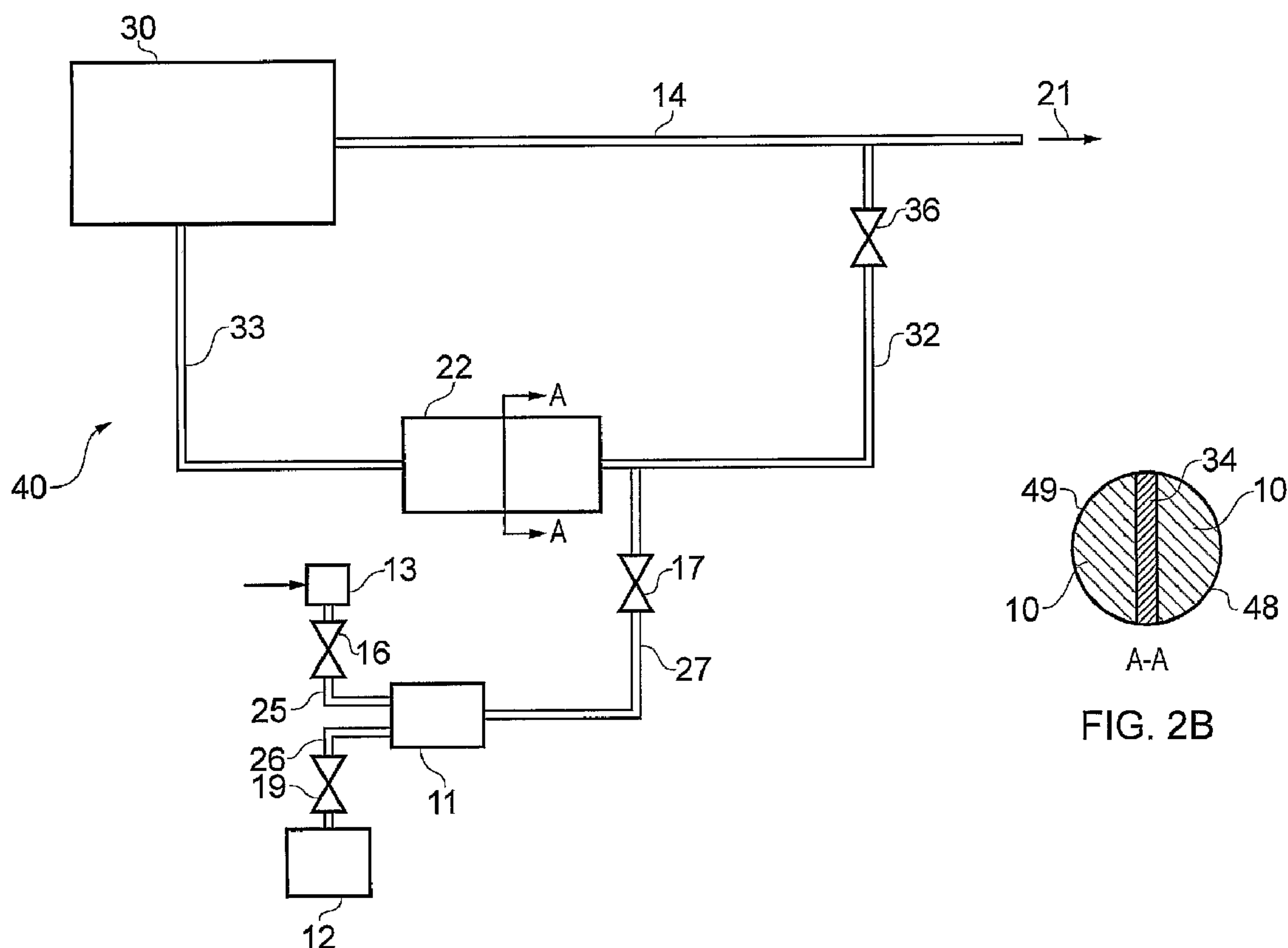

FIG. 2A

FIG. 2B

(57) Abrégé/Abstract:

Engine exhaust system for an internal combustion engine, the engine exhaust system comprising an exhaust conduit (14) connected to an engine (30), an exhaust gas return conduit (32,33) such that at least a part of the exhaust gas can be returned to

(57) **Abrégé(suite)/Abstract(continued):**

the engine. The exhaust gas return conduit, at least along a part of its length, is formed with at least two flow paths (48,49). The engine exhaust system further comprises a particle filter arranged in each of the at least two flow paths and at least one cold flame vaporizer (11) in which fuel is partially oxidized in preheated air to form a cold flame gas. The at least one cold flame vaporizer is arranged in fluid communication with all the flow paths such that the cold flame gas can flow through the particle filters, whereby the cold flame gas can be used to regenerate the particle filter in at least one of the exhaust flow paths while, simultaneously, exhaust gas can flow through the other exhaust flow path or exhaust flow paths. A method for the cleaning of a particle filter is also provided.

(12) INTERNATIONAL APPLICATION PUBLISHED UNDER THE PATENT COOPERATION TREATY (PCT)

(19) World Intellectual Property Organization
International Bureau(43) International Publication Date
5 March 2009 (05.03.2009)

PCT

(10) International Publication Number
WO 2009/028957 A1

(51) International Patent Classification:

F01N 3/025 (2006.01) F01N 3/08 (2006.01)

(21) International Application Number:

PCT/NO2008/000309

(22) International Filing Date:

1 September 2008 (01.09.2008)

(25) Filing Language:

English

(26) Publication Language:

English

(30) Priority Data:

60/968,899 30 August 2007 (30.08.2007) US

(71) Applicant (for all designated States except US): **ENERGY CONVERSION TECHNOLOGY AS** [NO/NO]; Martin Linges vei 25, N-1367 Snarøya (NO).

(72) Inventors; and

(75) Inventors/Applicants (for US only): **LUCKA, Klaus** [DE/DE]; Paul Gerhardt Strasse 11, D-52072 Aachen (DE). **KÖHNE, Stephan** [DE/DE]; Zeisigweg 37, D-52146 Würselen (DE).(74) Agents: **ONSAGERS AS** et al.; P.O.Box 6963 St. Olavs plass, N-0130 Oslo (NO).

(81) Designated States (unless otherwise indicated, for every kind of national protection available): AE, AG, AL, AM, AO, AT, AU, AZ, BA, BB, BG, BH, BR, BW, BY, BZ, CA, CH, CN, CO, CR, CU, CZ, DE, DK, DM, DO, DZ, EC, EE, EG, ES, FI, GB, GD, GE, GH, GM, GT, HN, HR, HU, ID, IL, IN, IS, JP, KE, KG, KM, KN, KP, KR, KZ, LA, LC, LK, LR, LS, LT, LU, LY, MA, MD, ME, MG, MK, MN, MW, MX, MY, MZ, NA, NG, NI, NO, NZ, OM, PG, PH, PL, PT, RO, RS, RU, SC, SD, SE, SG, SK, SL, SM, ST, SV, SY, TJ, TM, TN, TR, TT, TZ, UA, UG, US, UZ, VC, VN, ZA, ZM, ZW.

(84) Designated States (unless otherwise indicated, for every kind of regional protection available): ARIPO (BW, GH, GM, KE, LS, MW, MZ, NA, SD, SL, SZ, TZ, UG, ZM, ZW), Eurasian (AM, AZ, BY, KG, KZ, MD, RU, TJ, TM), European (AT, BE, BG, CH, CY, CZ, DE, DK, EE, ES, FI, FR, GB, GR, HR, HU, IE, IS, IT, LT, LU, LV, MC, MT, NL, NO, PL, PT, RO, SE, SI, SK, TR), OAPI (BF, BJ, CF, CG, CI, CM, GA, GN, GQ, GW, ML, MR, NE, SN, TD, TG).

Published:

- with international search report
- before the expiration of the time limit for amending the claims and to be republished in the event of receipt of amendments

(54) Title: PARTICLE FILTER ASSEMBLY AND METHOD FOR CLEANING A PARTICLE FILTER

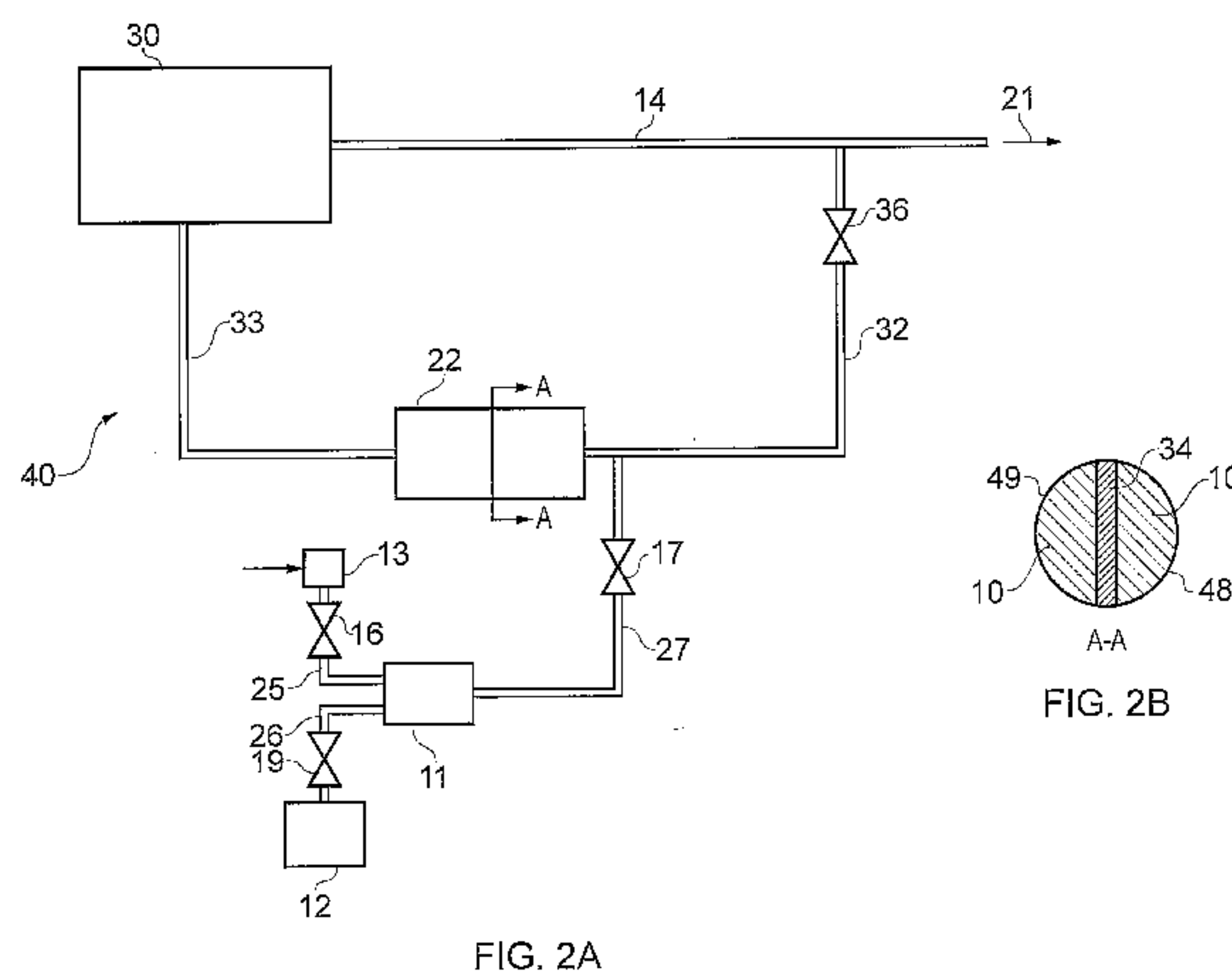

(57) **Abstract:** Engine exhaust system for an internal combustion engine, the engine exhaust system comprising an exhaust conduit (14) connected to an engine (30), an exhaust gas return conduit (32,33) such that at least a part of the exhaust gas can be returned to the engine. The exhaust gas return conduit, at least along a part of its length, is formed with at least two flow paths (48,49). The engine exhaust system further comprises a particle filter arranged in each of the at least two flow paths and at least one cold flame vaporizer (11) in which fuel is partially oxidized in preheated air to form a cold flame gas. The at least one cold flame vaporizer is arranged in fluid communication with all the flow paths such that the cold flame gas can flow through the particle filters, whereby the cold flame gas can be used to regenerate the particle filter in at least one of the exhaust flow paths while, simultaneously, exhaust gas can flow through the other exhaust flow path or exhaust flow paths. A method for the cleaning of a particle filter is also provided.

WO 2009/028957 A1

Particle filter assembly and method for cleaning a particle filter.

The present invention relates to a particle filter apparatus and an engine exhaust system wherein a particle filter is regenerated by using a cold flame gas. The invention also relates to a method for cleaning a particle filter and a method for
5 cleaning a particle filter arranged in an exhaust gas return system. The invention also relates to the use of the particle filter apparatus, the engine exhaust system and the methods for cleaning a particle filter where the exhaust gas originates from a compression ignition engine.

The cold flame is a phenomenon which has so far not received too much attention.
10 In a cold flame the fuel is partially oxidized in preheated air and the temperature is kept constant at about 450°C, and it is independent of air/fuel ratio and residence time. In the cold flame process, only 2-20% (typically 6-9%) of the calorific value of the fuel is released, and this heat is used to evaporate the fuel, giving a homogenous gaseous fuel. During developmental work, it has been observed that
15 the gas was able to remove carbon deposits from the reactor walls. The reason for this has not been established yet, but is thought to be due to free radicals that are present in the cold flame gas, i.e. the partially oxidized, gaseous fuel.

A more complete description of the cold flame gas phenomenon can be found in the American patent US 6,793,693.

20 Exhaust from compression ignition engines (often imprecisely called diesel engines), which operate on excess air, contains mainly particulates, NO_x and incomplete combustion products (HC and CO). Particulates can be removed using a filter downstream from the engine. After a while, the filter will be blocked and need to be regenerated. This is done by increasing the temperature in the exhaust
25 gas to above 800°C under oxidizing conditions and thereby burn away the carbon deposits. In order to allow for continuous operation, it is common to have two filters in parallel and a valve which sends the majority of the exhaust to one of the filters while the other is being regenerated.

Incomplete combustion products (HC and CO) can be removed by an oxidation
30 catalyst.

NO_x, on the other hand, can only be removed catalytically if the exhaust gas is slightly reducing (as in an Otto engine). This is not normally the case in a compression ignition engine.

One way to reduce NO_x emissions in a diesel engine is to recirculate some of the
35 exhaust back into the engine (EGR). While this works for smaller diesel engines operating on clean diesel fuel, it is not practical for larger engines operating on heavy fuel oil since it will produce particulates in the exhaust that will mix with the

lubricating oil and cause premature engine wear. Attempts to insert a filter in the EGR loop has not been successful since the exhaust also contains salts and other metal compounds which will melt during filter regeneration (when the temperature is increased to above 600°C) and cause permanent damage to the filter.

- 5 There is therefore an objective of the present invention to improve the regeneration of a particle filter and thereby extending its use to diesel engines running on heavy diesel fuels.

This objective is achieved by the present invention as defined in the independent claims. Further embodiments of the invention are defined in the dependent claims.

- 10 There is provided a particle filter apparatus comprising a particle filter which is arranged in an exhaust gas conduit of an internal combustion engine so that the exhaust gas, containing particulate matter and soot, is cleaned when passing through the particle filter. The particle filter apparatus further comprises a cold flame vaporizer in which fuel is partially oxidized in preheated air to form a cold flame
15 gas, the cold flame vaporizer being arranged in fluid communication with the exhaust conduit such that the cold flame gas can flow through the particle filter, thereby removing deposits of soot which has accumulated in the particle filter.

- The cold flame vaporizer is a standard cold flame vaporizer in which the fuel can be partially oxidized in preheated air to provide fully vaporised fuel with free radicals.
20 In a cold flame vaporizer air and fuel is mixed in a proportion of 0,3 – 1,0 (1,0 is stoichiometric air/fuel ratio), but only a small fraction of the air is used in the cold flame reaction.

The exhaust gas conduit may be a pipe or similar of any cross sectional shape, or the exhaust gas conduit may be formed as internal conduits in a larger body.

- 25 The means for preheating the air may be a heat exchanger in which the heat of the exhaust gas warms up the air. It would also be possible to use other means for preheating the, for instance electrical heating means.

- The particle filter apparatus is further provided with one or more valve means which controls the flow of exhaust gas through the exhaust gas conduit. When
30 regenerating the particle filter in the exhaust gas conduit, the flow of exhaust gas can therefore at least partially be shut off.

Furthermore, the particle filter apparatus is provided with valve means which controls the flow of cold flame gas from the cold flame vaporizer into the exhaust gas conduit and through the particle filter.

- 35 These valve means may be controlled such that the particle filter is regenerated, for instance, at specific time intervals, or when the pressure drop across a particle filter

reaches a predetermined level indicating that the particle filter needs to be regenerated.

5 The cold flame vaporizer may be arranged outside the exhaust gas conduit and, if necessary, connected to the exhaust gas conduit with fluid lines. If the cold flame vaporizer is mounted to the exhaust gas conduit, then there may only be necessary to provide openings into the exhaust gas conduit, while if the cold flame vaporizer is arranged separate from the exhaust gas conduit, fluid lines will be provided connecting the cold flame vaporizer and the exhaust gas conduit.

10 In an embodiment of the invention, the cold flame vaporizer can also be arranged inside the exhaust gas conduit. In that case, there is no need for fluid lines as the cold flame vaporizer may just release the cold flame gas into the exhaust gas conduit through openings including said valve means.

15 Furthermore, the exhaust gas apparatus comprises a fuel supply which is arranged in fluid communication with the cold flame vaporizer. The exhaust gas apparatus also comprises an air supply and means for preheating the air, the air supply being in fluid communication with the cold flame vaporizer. In order to control the flow of fuel and preheated air into the cold flame vaporizer, the exhaust gas apparatus comprises one or more valve means controlling the flow of fuel and preheated air to said cold flame vaporizer.

20 There is also provided an engine exhaust system for an internal combustion engine, where the engine exhaust system comprises an exhaust conduit connected to the engine and an exhaust gas return conduit such that at least a part of the exhaust gas can be returned to the engine. The exhaust gas return conduit is, at least along a part of its length, formed with at least two flow paths. The engine exhaust system
25 further comprises a particle filter arranged in each of the at least two flow paths and at least one cold flame vaporizer in which fuel is partially oxidized in preheated air to form a cold flame gas. The at least one cold flame vaporizer is arranged in fluid communication with all the flow paths such that the cold flame gas can flow through any of the particle filters. The cold flame gas can thereby be used to
30 regenerate the particle filter in at least one of the exhaust flow paths while, simultaneously, exhaust gas can flow through the other exhaust flow path or exhaust flow paths.

35 The cold flame vaporizer is, as mentioned above, a standard cold flame vaporizer in which the fuel can be partially oxidized in preheated air. In the cold flame vaporizer air and fuel is mixed in a proportion of 0,3 – 1,0 (1,0 is stoichiometric air/fuel ratio), but only a small fraction of the air is used in the cold flame reaction.

The exhaust gas conduit may be a pipe or similar of any cross sectional shape, or the exhaust gas conduit may be formed as internal conduits in a larger body.

The means for preheating the air may be a heat exchanger in which the heat of the exhaust gas warms up the air. It would also be possible to use other means for preheating the, for instance electrical heating means.

5 The flow paths may be formed by providing the exhaust gas return conduit, at least along a part of its length, with one or more partitions such that two or more separate flow paths for the exhaust gas are formed in the exhaust conduit section. These partitions may be one or more plates dividing the exhaust gas return conduit in two or more flow paths. Alternatively, the flow paths may be formed by providing the exhaust gas return conduit with at least two separate conduits through which the
10 exhaust gas can flow.

The engine exhaust system is preferably provided with one or more valve means which controls the flow of exhaust gas through the flow paths of the exhaust gas return conduit. The valve means may close off one or more flow paths for the flow of exhaust gas. The engine exhaust system is preferably also provided with one or
15 more valve means controlling the flow of cold flame gas from the at least one cold flame vaporizer to the exhaust gas return conduit and the particle filters in the flow paths. These valve means may be controlled such that the particle filters are regenerated, for instance, at specific time intervals, or when the pressure drop across a particle filter reaches a predetermined level indicating that the particle
20 filter needs to be regenerated.

The cold flame vaporizer may be arranged outside the exhaust gas conduit and, if necessary, connected to the exhaust gas conduit with fluid lines. If the cold flame vaporizer is mounted to the exhaust gas conduit, then there may only be necessary to provide openings into the exhaust gas conduit, while if the cold flame vaporizer
25 is arranged separate from the exhaust gas conduit, fluid lines will be provided connecting the cold flame vaporizer and the exhaust gas conduit.

In an embodiment of the invention, the cold flame vaporizer can also be arranged inside the exhaust gas conduit. In that case, there is no need for fluid lines as the cold flame vaporizer may just release the cold flame gas into the exhaust gas
30 conduit through openings including said valve means.

The engine exhaust system further comprises a fuel supply which is arranged in fluid communication with the at least one cold flame vaporizer. Preferably, there is also provided valve means controlling the flow of fuel to the at least one cold flame vaporizer.

35 The engine exhaust system also comprises an air supply and, as mentioned above, means for preheating the air, the air supply being arranged in fluid communication with the at least one cold flame vaporizer. Preferably, there is also provided valve means controlling the flow of preheated air to the at least one cold flame vaporizer.

There is also provided a method for cleaning a particle filter with deposits of particulate matter and soot originating from an exhaust gas, the filter being arranged in an exhaust conduit, the method comprising the steps of providing a cold flame gas, and letting the cold flame gas flow through the particle filter, whereby the deposited soot is removed from the particle filter.

The cold flame gas may, as explained above, be provided by partially oxidizing fuel in preheated air in a cold flame vaporizer. Obviously, the cold flame vaporizer is arranged in fluid communication with the exhaust conduit. In the cold flame vaporizer air and fuel is mixed in a proportion of 0,3 – 1,0 (again 1,0 is stoichiometric air/fuel ratio), but only a small fraction of the air is used in the cold flame reaction.

Furthermore, the method comprises the step of providing one or more valve means for controlling the flow of cold flame gas from the cold flame vaporizer into the exhaust conduit.

The method also comprises the step of providing a fuel supply arranged in fluid communication with the cold flame vaporizer, and an air supply and heating means for the preheating of the air, the air supply being arranged in fluid communication with the cold flame vaporizer.

Preferably, the method also comprises the step of providing one or more valve means for controlling the flow of fuel and preheated air to the cold flame vaporizer.

Furthermore, an oxidation catalyst may be arranged in each flow path of the exhaust gas return conduit such that the particle filter, the NO_x trap and the oxidation catalyst is formed in a single unit. Alternatively, the oxidation catalyst may be arranged separately further downstream where the exhaust flows in a single flow path.

There is also provided a method for cleaning a particle filter arranged in an exhaust gas return system of an internal combustion engine, the exhaust gas return system comprising an exhaust gas return conduit which, at least along a part of its length, is formed with at least two flow paths, the at least two flow paths each being provided with a particle filter for the removal of particulate matter and soot in the exhaust gas, wherein the method comprises the steps of

- providing a cold flame gas,
- letting the cold flame gas flow through the particle filter in at least one of the flow paths of the exhaust gas return conduit, thereby regenerating the particle filter by removing deposited soot.

The cold flame gas may be provided by partially oxidizing fuel in preheated air in at least one cold flame vaporizer where the cold flame vaporizer is arranged in fluid

communication with all the flow paths of the exhaust gas return conduit. In the cold flame vaporizer air and fuel is mixed in a proportion of 0,3 – 1,0 (again 1,0 is stoichiometric air/fuel ratio), but only a small fraction of the air is used in the cold flame reaction.

- 5 The method also comprises the step of providing one or more valve means for separately controlling the flow of cold flame gas from the cold flame vaporizer into each flow path of the exhaust gas conduit.

10 The method also comprises the step of providing a fuel supply arranged in fluid communication with the cold flame vaporizer, and an air supply and heating means for the preheating of the air, the air supply being arranged in fluid communication with the cold flame vaporizer.

The method also comprises the step of providing one or more valve means for controlling the flow of fuel and preheated air to the cold flame vaporizer.

15 In order to remove particulate matter from the exhaust gas before the exhaust gas passes through the NOx trap, the method also comprises the step of arranging, in each flow path in the exhaust conduit section, the NOx trap downstream of the respective particle filter.

20 The method also comprises the step of arranging an oxidation catalyst in the exhaust conduit section downstream of the particle filter and the NOx trap. An oxidation catalyst may be arranged in each flow path of the exhaust gas return conduit such that the particle filter, the NOx trap and the oxidation catalyst is formed in a single unit. Alternatively, the oxidation catalyst may be arranged separately further downstream where the exhaust flows in a single flow path.

25 There is also provided a use of the particle filter apparatus where the exhaust gas originates from a compression ignition engine running on diesel or heavy fuel oil.

There is also provided a use of the engine exhaust system where the exhaust gas originates from a compression ignition engine running on diesel or heavy fuel oil.

30 There is also provided a use of the method for cleaning a particle filter where the exhaust gas originates from a compression ignition engine running on diesel or heavy fuel oil.

There is also provided a use of the method for cleaning a particle filter where the exhaust gas originates from a compression ignition engine running on diesel or heavy fuel oil.

35 Above, only a cold flame gas produced by a cold flame vaporizer has been mentioned. A cold flame is one example of a partially oxidized fuel gas among a number of other partially oxidized fuel gases with the same properties. The present

invention should therefore not be seen as limited to only a cold flame gas, but should include other partially oxidized fuel gases with the same or similar properties as the cold flame gas.

5 In the following, an embodiment of the invention is disclosed in detail with reference to the enclosed figures, where

Figure 1 illustrates an embodiment of the invention where a particle filter is arranged in an exhaust conduit

Figure 2a illustrates an embodiment of the invention where the particle filter is arranged in an EGR loop.

10 Figure 2b is the section A-A of the particle filter on Figure 2a.

Figure 3 illustrates another embodiment of the invention where the particle filter is arranged in an EGR loop.

15 Fig 1 schematically illustrates an embodiment of the present invention. Exhaust gas, indicated with the arrow 20 flows in an exhaust gas conduit 14. Valve means 18 are provided to control the flow of exhaust gas through the exhaust gas conduit. Further downstream there is arranged a particle filter 10 which cleans the exhaust gas for particulate matter. At certain intervals the particle filter needs to be regenerated, and that may be carried out, according to the present invention, by providing a cold flame gas and letting it flow through the particle filter until the
20 particle filter is regenerated. In figure 1 the cold flame gas is produced a cold flame vaporizer 11. A fuel supply 12, for instance diesel or heavy fuel oil, is connected to the cold flame vaporizer 11 through fluid line 26. Valve means 19 is provided to control the flow of fuel to the cold flame vaporizer 11. There is also provided a fuel supply 13 which may include an air intake 15 and an air filter (not shown). The air
25 supply 13 is connected to the cold flame vaporizer through a fluid line 25. Valve means 16 controls the flow of air from the air supply 13 to the cold flame vaporizer 11.

30 Preferably, there is also provided heating means (not shown) for preheating the air before being fed to the cold flame vaporizer 11. By adjust the valve means 16, 19 properly, the desired ration of fuel and air may be achieved.

The cold flame gas is fed through fluid line 27 to the exhaust gas conduit just upstream for the particle filter 10. Valve means 17 is provided to control the flow of cold flame gas from the cold flame vaporizer 11 to the exhaust gas conduit 14 and to the exhaust gas conduit 14.

35 When the particle filter 11 needs to be regenerated, which may be noticed by an increased pressure drop over the filter indicating that cleaning is needed, the valve

means 18 is preferably closed and the valve means 17 opens for the flow of cold flame gas through the particle filter 10, and thereby regenerating it.

In figure 2a-b and 3a-b, two similar embodiments of the invention is illustrated. An engine exhaust system for an internal combustion engine 30, preferably a
5 compression ignition engine, is shown. Furthermore, there is provided an exhaust gas conduit 14 through which the exhaust, indicated by arrow 21, flows. In order to reduce the content of NO_x in the exhaust from the engine 30, there is provided an EGR loop (exhaust gas return loop).

In figure 2a, the EGR loop is shown with a exhaust gas return conduit 32, 33. The
10 exhaust gas return conduit comprises a fluid line 32 extending between the exhaust conduit 14 and a particle filter section 22, and a fluid line 33 extending between the particle filter section 22 and the engine 30. As can be seen on figure 2b the exhaust gas return conduit 32, 33 is, at least along a part of its length divided into at least two flow paths 48, 49. This length of the particle filter section will preferably
15 correspond the length of a particle filter 10. The flow paths are formed by a partition 34 as can be seen on figure 2b.

A particle filter 10 is provided in each of the flow paths 48, 49 and valve means (not shown) or other means are provided to control the flow of exhaust gas through the 48, 49.

20 There is furthermore provided a cold flame vaporizer 11 with a fuel supply 12 and an air supply 13 in the same manner as explained above. The cold flame gas produced in the cold flame vaporizer 11 is fed to the fluid line 32 just in front of the particle filter section 10. When valve means 17 is opened, cold flame gas may flow through one or both the flow paths 48, 49.

25 When one of the particle filters 10 in the particle filter section 22 needs to be regenerated, valve means or other means blocks the flow path 32, 33 in which the particle filter 10 to be regenerated is located, for the flow of exhaust gas. The valve means 17 opens and lets cold flame gas flow through the particle filter 10 to be regenerated. When the particle filter is regenerated the position of the valves may
30 be switched such that the exhaust gas flows through the particle filter 10 which has just been regenerated, while the cold flame gas directed through the particle filter that needs to be regenerated. The particle filters may be considered to be regenerated, for instance when the pressure drop over the particle filter drops below a certain value.

35 In this way there is no need to close the EGR loop while the filters are being regenerated. In figure 2b there is shown that the particle filter section 22 is divided into two flow paths 48, 49 with particle filters 10, but obviously, more than two flow paths may be provided if that is deemed necessary.

The embodiment of the invention shown in figure 3a and 3b is similar to the embodiment shown in figure 2a and 2b. The same numerals have been used for the same features, so only the parts that differ between the two embodiments will be explained below.

- 5 The difference between the two embodiments is that in the embodiment shown on figure 3a and 3b, the flow paths are formed by two separate fluid lines instead of being partitions of a single exhaust conduit (the particle filter section in the embodiment in figure 2a).

10 In the ERG loop 40, the exhaust gas flows in two (on the drawing) parallel fluid lines 38, 39. In each of the two fluid lines 38 and 39 there is provided a particle filter 10 and valve means for controlling the flow of the exhaust gas through the two fluid lines 38, 39. The cold flame gas from the cold flame vaporizer 11 is controlled by valve means 17. When the particle filters needs to be regenerated, the valve means are adjusted such that cold flame gas flows through one particle filter 15 10, thereby regenerating it, while exhaust gas is guided through the other particle filter 10. After the first particle filter has been regenerated, the positions of the valve means are switched such that the exhaust gas flows through the particle filter which has just been regenerated while the cold flame gas flows through the particle filter that still needs to be regenerated.

- 20 As for the embodiment shown in figure 2a and 2b, there is possible to provide more than two flow paths 38, 39 if that is needed.

AMENDED CLAIMS (CLEAN COPY)

1. Particle filter apparatus comprising a particle filter which is arranged in an exhaust gas conduit of an internal combustion engine, wherein the exhaust gas, containing particulate matter and soot, is cleaned when passing through the particle filter, characterized in that the particle filter apparatus further comprises a cold flame vaporizer in which fuel is partially oxidized in preheated air to form a cold flame gas, the cold flame vaporizer being arranged in fluid communication with the exhaust conduit such that the cold flame gas can flow through the particle filter, thereby removing deposits of soot which has accumulated in the particle filter.
2. Particle filter apparatus according to claim 1, characterized in that the particle filter apparatus is provided with one or more valve means which controls the flow of exhaust gas through the exhaust gas conduit.
3. Particle filter apparatus according to claim 1 or 2, characterized in that the particle filter apparatus is provided with valve means which controls the flow of cold flame gas from the cold flame vaporizer into the exhaust gas conduit and through the particle filter.
4. Particle filter apparatus according to one of the claims 1-3, characterized in that the cold flame vaporizer is arranged outside the exhaust flow conduit and, if necessary, connected to the exhaust gas conduit with fluid lines.
5. Particle filter apparatus according to one of the claims 1-3, characterized in that the cold flame vaporizer is arranged inside the exhaust gas conduit.
6. Particle filter apparatus according to one of the claims 1-5, characterized in that the particle filter apparatus comprises a fuel supply which is arranged in fluid communication with the cold flame vaporizer.
7. Particle filter apparatus according one of the claims 1-6, characterized in that the particle filter apparatus comprises an air supply and means for preheating the air, the air supply being in fluid communication with the cold flame vaporizer.
8. Particle filter apparatus according to claim 6 or 7, characterized in that the particle filter apparatus comprises one or more valve means controlling the flow of fuel and preheated air to the cold flame vaporizer.

9. Engine exhaust system for an internal combustion engine, the engine exhaust system comprising an exhaust conduit connected to the engine, an exhaust gas return conduit such that at least a part of the exhaust gas can be returned to the engine, the exhaust gas return conduit, at least along a part of its length, being formed with at least two flow paths, the engine exhaust system further comprising a particle filter arranged in each of the at least two flow paths, characterized in that the engine exhaust system further comprises at least one cold flame vaporizer in which fuel is partially oxidized in preheated air to form a cold flame gas, the at least one cold flame vaporizer being arranged in fluid communication with all the flow paths such that the cold flame gas can flow through the particle filters, whereby the cold flame gas can be used to regenerate the particle filter in at least one of the exhaust flow paths while, simultaneously, exhaust gas can flow through the other exhaust flow path or exhaust flow paths.
10. Engine exhaust system according to claim 9, characterized in that the flow paths are formed by providing the exhaust gas return conduit with one or more partitions, at least along a part of its length, such that two or more separate flow paths for the exhaust gas are formed in the exhaust conduit section.
11. Engine exhaust system according to claim 9, characterized in that the flow paths are formed by providing the exhaust gas return conduit with at least two separate conduits through which the exhaust gas can flow.
12. Engine exhaust system according to one of the claims 9-11, characterized in that the engine exhaust system is provided with one or more valve means which controls the flow of exhaust gas through the flow paths of the exhaust gas return conduit.
13. Engine exhaust system according to one of the claims 9-12, characterized in that the engine exhaust system is provided with one or more valve means controlling the flow of cold flame gas from the at least one cold flame vaporizer to the exhaust gas return conduit and the particle filters in the flow paths.
14. Engine exhaust system according to one of the claims 9-13, characterized in that the at least one cold flame vaporizer is arranged outside the flow paths of the exhaust gas return conduit and, if necessary, connected to the flow paths with fluid lines.
15. Engine exhaust system according to one of the claims 9-13,

characterized in that the at least one cold flame vaporizer is arranged inside the flow paths of the exhaust gas return conduit.

16. Engine exhaust system according to one of the claims 9-15,

5 characterized in that the engine exhaust system comprises a fuel supply which is arranged in fluid communication with the at least one cold flame vaporizer, and valve means controlling the flow of fuel to the at least one cold flame vaporizer.

17. Engine exhaust system according one of the claims 9-16,

10 characterized in that the engine exhaust system comprises an air supply and means for preheating the air, the air supply being arranged in fluid communication with the at least one cold flame vaporizer, and valve means controlling the flow of preheated air to the at least one cold flame vaporizer.

18. Method for cleaning a particle filter with deposits of particulate matter and soot originating from an exhaust gas, the filter being arranged in an exhaust conduit,

15 characterized in that the method comprises the steps of providing a cold flame gas, and letting the cold flame gas flow through the particle filter, whereby the soot is removed from the particle filter.

19. Method according to claim 18,

20 characterized by providing one or more valve means for controlling the flow of cold flame gas from a cold flame vaporizer, in which the fuel is partially oxidized in preheated air to form the cold flame gas, into the exhaust conduit.

20. Method according one of the claim 19,

25 characterized by providing a fuel supply arranged in fluid communication with the cold flame vaporizer, and an air supply and heating means for the preheating of the air, the air supply being arranged in fluid communication with the cold flame vaporizer.

21. Method according to claim 20,

30 characterized by providing one or more valve means for controlling the flow of fuel and preheated air to the cold flame vaporizer.

22. Method for cleaning a particle filter arranged in an exhaust gas return system of an internal combustion engine, the exhaust gas return system comprising an exhaust gas return conduit which, at least along a part of its length, is formed with at least two flow paths, the at least two flow paths each being provided with a particle filter for the removal of particulate matter and soot in the exhaust gas,

35

characterized in that the method comprises the steps of
- providing a cold flame gas,

- letting the cold flame gas flow through the particle filter in at least one of the flow paths of the exhaust gas return conduit, thereby regenerating the particle filter by removing deposited soot.

23. Method according to claim 22,
5 c h a r a c t e r i z e d b y p r o v i d i n g o n e o r m o r e v a l v e m e a n s f o r s e p a r a t e l y
controlling the flow of cold flame gas from a cold flame vaporizer, in which fuel
is partially oxidized in preheated air, into each flow path of the exhaust gas
conduit.
24. Method according to claim 23,
10 c h a r a c t e r i z e d b y p r o v i d i n g a f u e l s u p p l y a r r a n g e d i n f l u i d
communication with the cold flame vaporizer, and an air supply and heating
means for the preheating of the air, the air supply being arranged in fluid
communication with the cold flame vaporizer.
25. Method according to claim 24,
15 c h a r a c t e r i z e d b y p r o v i d i n g o n e o r m o r e v a l v e m e a n s f o r c o n t r o l l i n g
the flow of fuel and preheated air to the cold flame vaporizer.
26. Method according to one of the claims 22-25,
c h a r a c t e r i z e d b y a r r a n g i n g , i n e a c h f l o w p a t h i n t h e e x h a u s t
conduit section, the NOx trap downstream of the respective particle filter.
- 20 27. Method according to one of the claims 22-26,
c h a r a c t e r i z e d b y a r r a n g i n g a n o x i d a t i o n c a t a l y s t i n t h e e x h a u s t
conduit section downstream of the particle filter and the NOx trap.
- 25 28. Use of the particle filter apparatus according to one of the claims 1-8 where the
exhaust gas originates from a compression ignition engine running on diesel or
heavy fuel oil.
29. Use of the engine exhaust system according to one of the claims 9-17 where the
exhaust gas originates from a compression ignition engine running on diesel or
heavy fuel oil.
- 30 30. Use of the method for cleaning a particle filter according to one of the claims
18-21 where the exhaust gas originates from a compression ignition engine
running on diesel or heavy fuel oil.
31. Use of the method for cleaning a particle filter according to one of the claims
22-27 where the exhaust gas originates from a compression ignition engine
running on diesel or heavy fuel oil.
- 35 32. Use of a cold flame gas to regenerate a particle filter with deposits of soot.

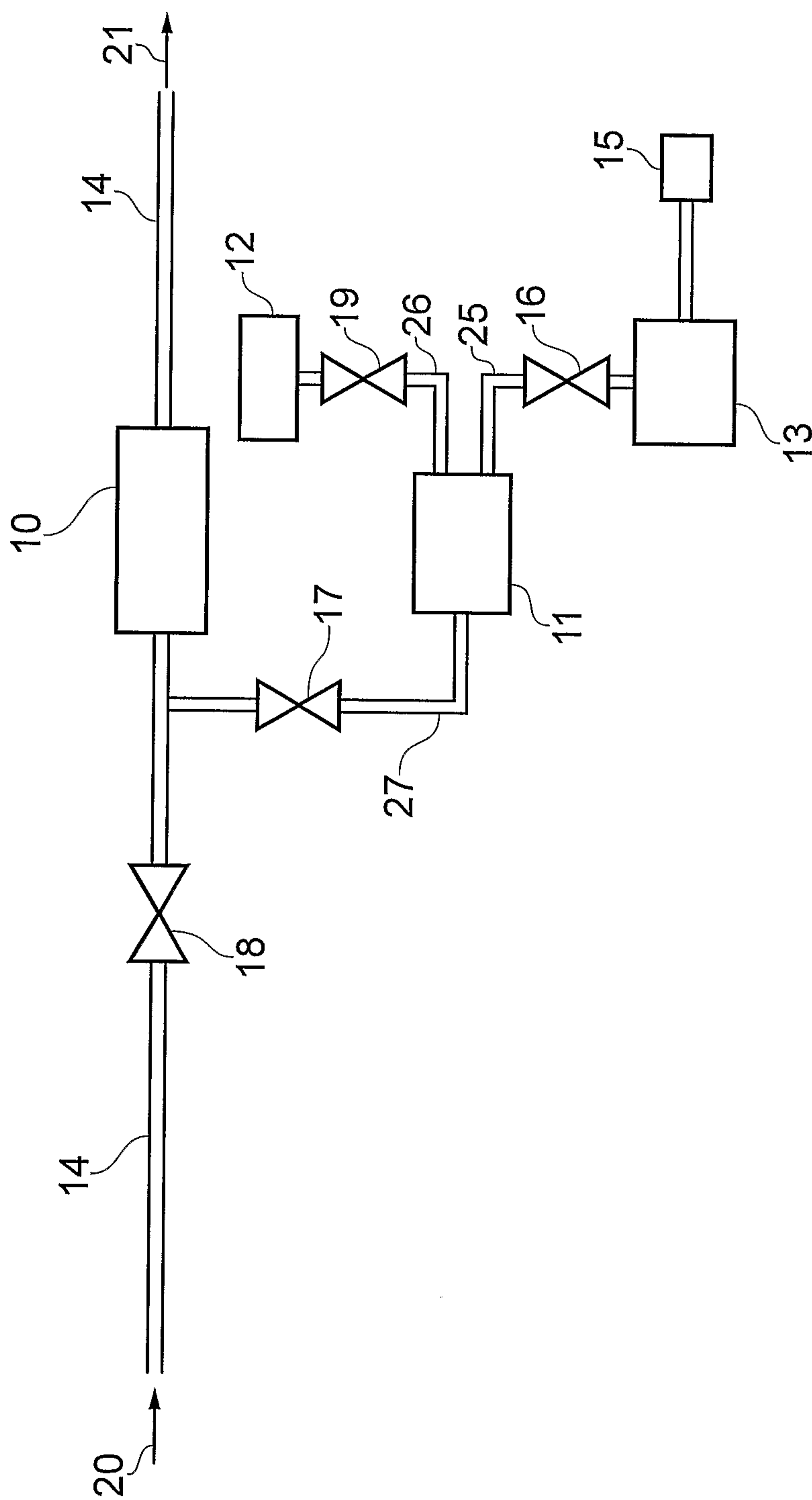

FIG. 1

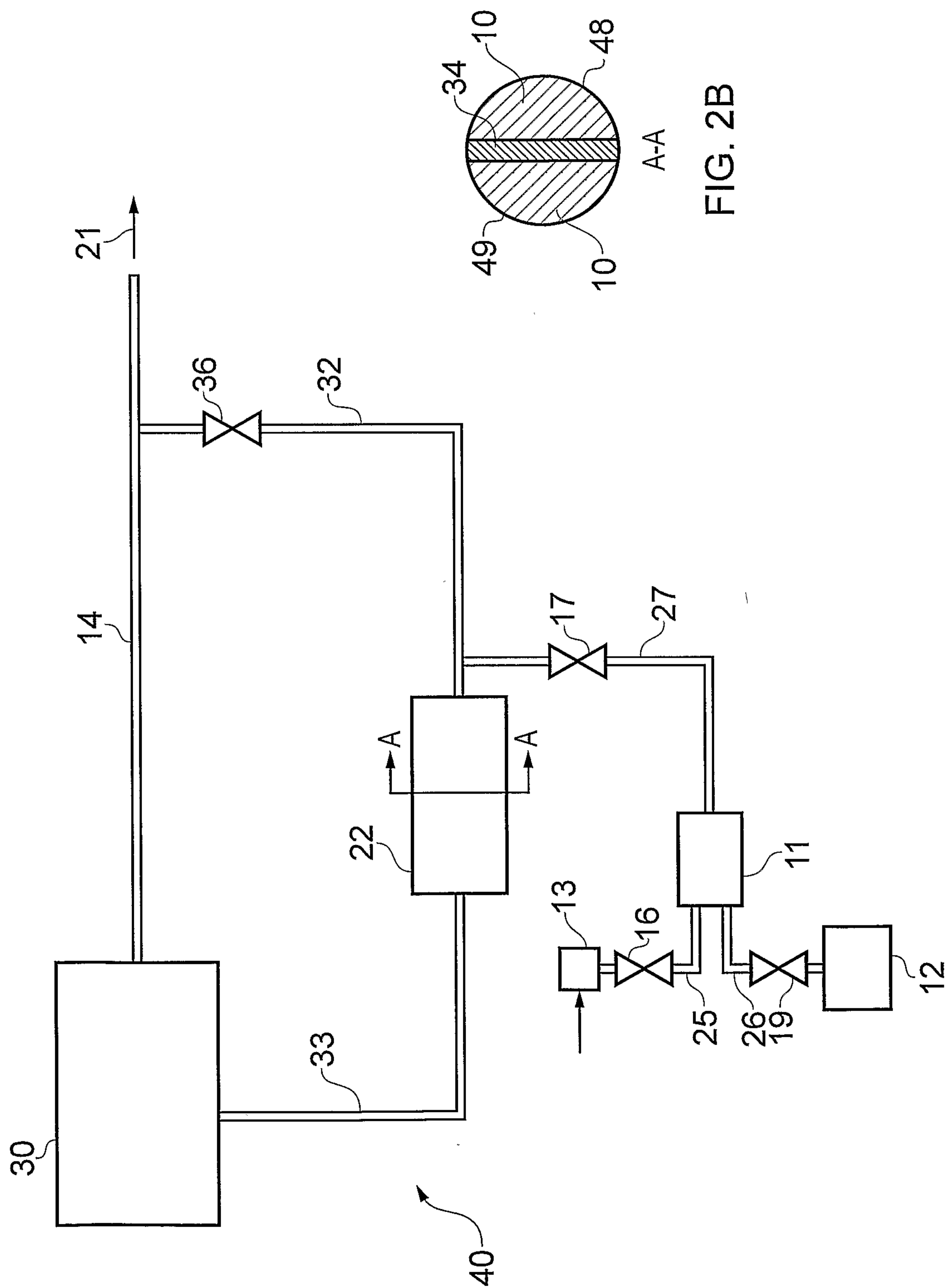

FIG. 2B

FIG. 2A

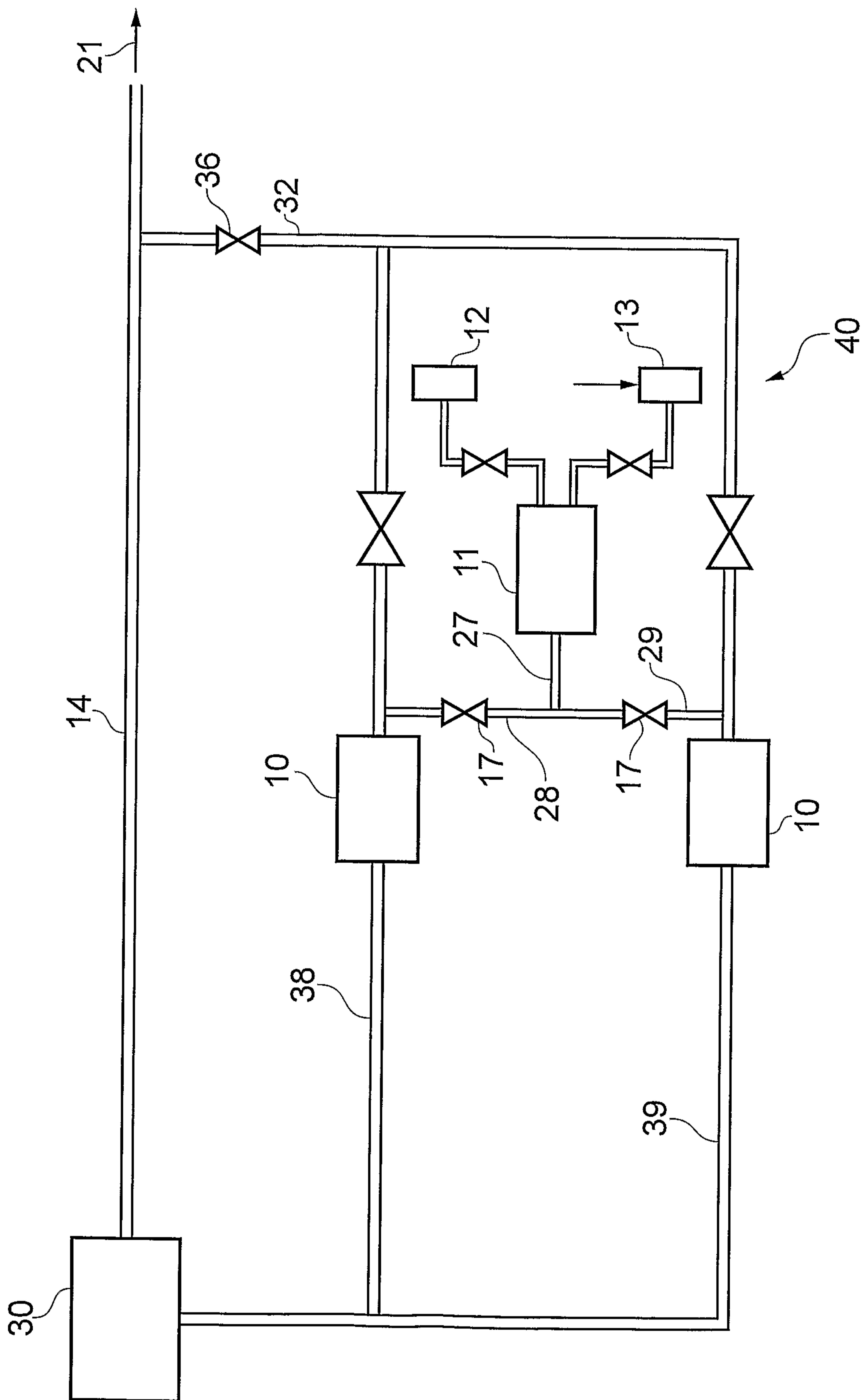

FIG. 3

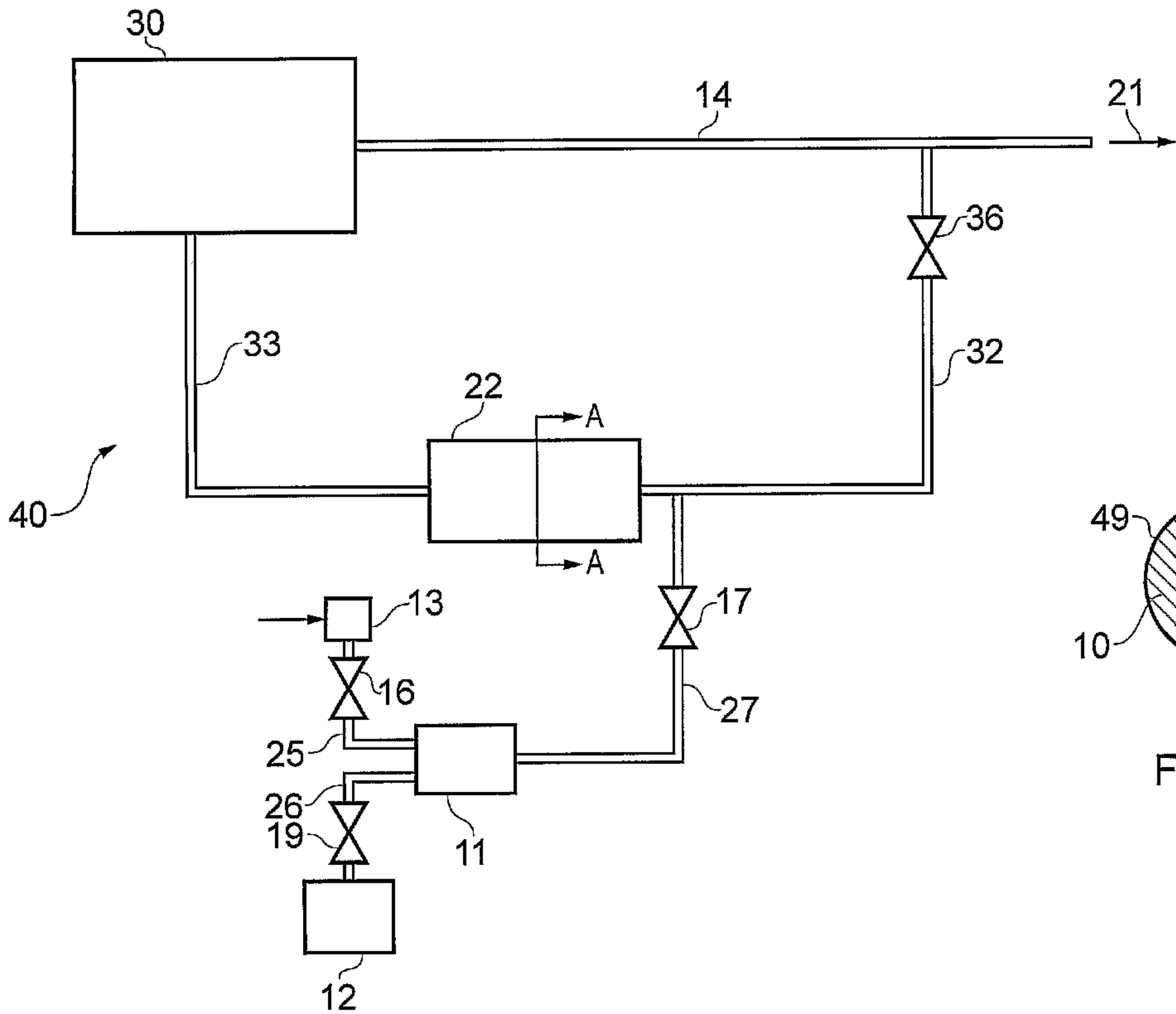

FIG. 2A

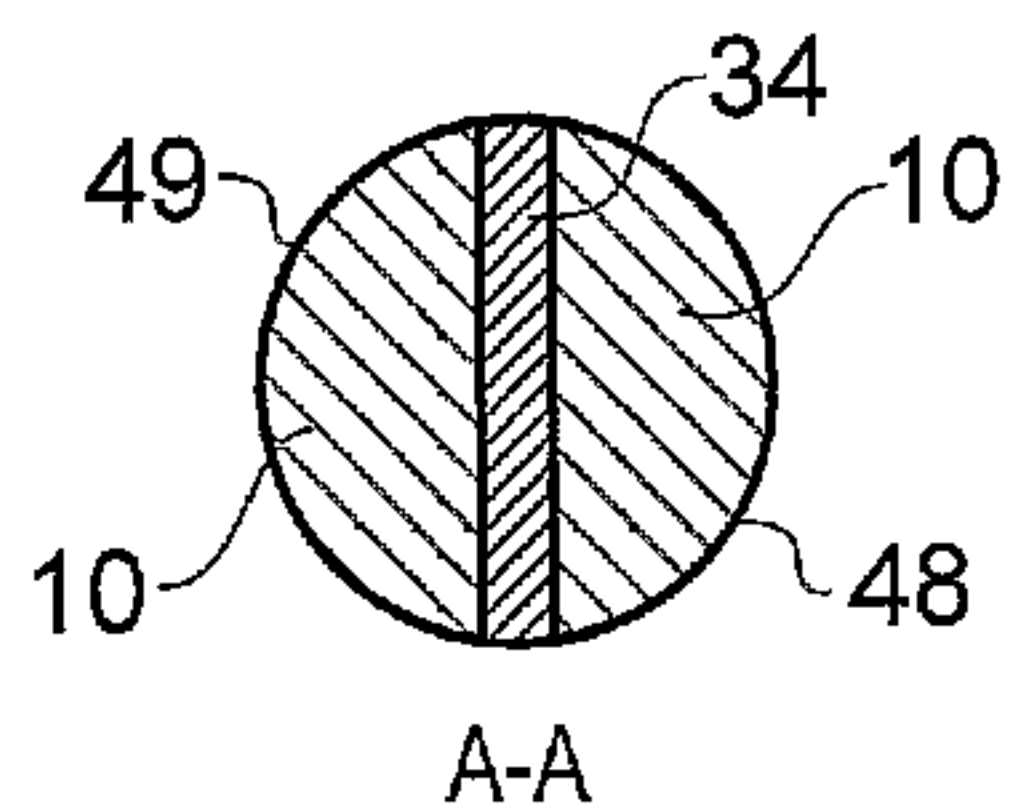

FIG. 2B