

(19) World Intellectual Property Organization  
International Bureau



(43) International Publication Date  
17 April 2008 (17.04.2008)

PCT

(10) International Publication Number  
**WO 2008/043573 A1**

(51) International Patent Classification:

*F24H 1/12* (2006.01)      *F28D 7/12* (2006.01)  
*F24H 1/20* (2006.01)      *F28D 20/00* (2006.01)  
*F28D 7/10* (2006.01)

Down BT23 4FZ (GB). **COLLINS, Scott** [GB/GB]; 63 Glebe Manor, Newtownabbey, County Antrim BT36 6HF (GB). **STEELE, Ian** [GB/GB]; 201 Sandown Road, Belfast BT5 6GX (GB).

(21) International Application Number:

PCT/EP2007/008915

(74) Agents: **WALLACE, Alan** et al.; F.R. Kelly & Co., 4 Mount Charles, Belfast BT7 1NZ, Northern Ireland (GB).

(22) International Filing Date: 12 October 2007 (12.10.2007)

(81) Designated States (unless otherwise indicated, for every kind of national protection available): AE, AG, AL, AM, AT, AU, AZ, BA, BB, BG, BH, BR, BW, BY, BZ, CA, CH, CN, CO, CR, CU, CZ, DE, DK, DM, DO, DZ, EC, EE, EG, ES, FI, GB, GD, GE, GH, GM, GT, HN, HR, HU, ID, IL, IN, IS, JP, KE, KG, KM, KN, KP, KR, KZ, LA, LC, LK, LR, LS, LT, LU, LY, MA, MD, ME, MG, MK, MN, MW, MX, MY, MZ, NA, NG, NI, NO, NZ, OM, PG, PH, PL, PT, RO, RS, RU, SC, SD, SE, SG, SK, SL, SM, SV, SY, TJ, TM, TN, TR, TT, TZ, UA, UG, US, UZ, VC, VN, ZA, ZM, ZW.

(25) Filing Language: English

(26) Publication Language: English

(30) Priority Data:  
0620262.6      13 October 2006 (13.10.2006)      GB

(71) Applicant (for all designated States except US): **WILLIS HEATING AND PLUMBING CO LTD** [GB/GB]; Unit 28 Somerton Industrial Park, Dargan Crescent, Belfast BT3 9JB (GB).

(72) Inventors; and

(75) Inventors/Applicants (for US only): **WILLIS, John** [GB/GB]; 25 Aldergrange Park, Newtownards, County

(84) Designated States (unless otherwise indicated, for every kind of regional protection available): ARIPO (BW, GH, GM, KE, LS, MW, MZ, NA, SD, SL, SZ, TZ, UG, ZM, ZW).

[Continued on next page]

(54) Title: WATER HEATING APPARATUS AND SYSTEM

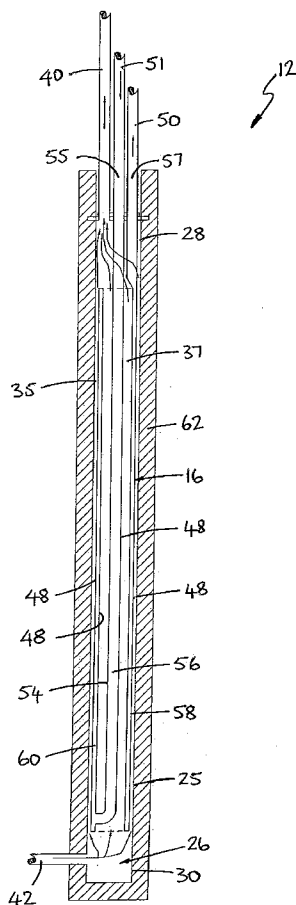

(57) Abstract: A fluid heating apparatus comprising a chamber for containing a quantity of fluid to be heated and a heating device in the chamber. The heating device comprises a hollow body having a flow inlet and a return outlet to allow a heating medium to flow through the hollow body. The hollow body has a first heat exchanging surface extending along the chamber between a fluid inlet and fluid outlet and defining a smooth, straight fluid passage between the inlet and outlet. The preferred apparatus takes the form of a thermosyphon and is particularly suited for use with a water storage tank, where it is arranged to cause thermosyphonic circulation of water between the thermosyphon and the tank.

WO 2008/043573 A1



ZW), Eurasian (AM, AZ, BY, KG, KZ, MD, RU, TJ, TM),  
European (AT, BE, BG, CH, CY, CZ, DE, DK, EE, ES, FI,  
FR, GB, GR, HU, IE, IS, IT, LT, LU, LV, MC, MT, NL, PL,  
PT, RO, SE, SI, SK, TR), OAPI (BF, BJ, CF, CG, CI, CM,  
GA, GN, GQ, GW, ML, MR, NE, SN, TD, TG).

**Published:**

— *with international search report*

## Water Heating Apparatus and System

### **Field of the Invention**

5 The present invention relates to heating systems. The invention relates particularly to water heating systems for installation in domestic or commercial buildings, and to heating apparatus suitable for use in same.

### **Background to the Invention**

10

A conventional water heating system includes a heating element located inside a water storage tank. The heating element is typically located at or near the bottom of the tank. Cold water in the bottom of the tank is heated by the heating element and disperses throughout the tank.

15

It is known to use an external energy source to heat the heating element. In such cases the heating element may comprise one or more coils located in the bottom of the tank and carrying a heating medium, typically water. The heating medium is heated externally of the tank and the heat energy is then imparted to the water in  
20 the tank via the coil(s).

It is increasingly common to use a renewal energy source, e.g. solar energy, to heat the heating medium. However, solar heated systems tend to have unsatisfactory water draw-off temperature, particularly in environments with  
25 unpredictable weather or marginal or intermittent sunlight. Moreover, in instances where an existing conventional heating system is converted to a solar powered heating system, the existing storage tank is typically removed and replaced with a new storage tank and associated equipment. This is relatively expensive and is considered to be wasteful since many of the removed tanks are relatively intact.  
30 Furthermore, fitting a new storage tank can unbalance, and/or expose faults in, the remainder of the heating system leading to customer dissatisfaction.

It would be desirable to provide an improved system which mitigates at least some of the problems identified above.

### Summary of the Invention

5

A first aspect of the invention provides a fluid heating apparatus comprising an body defining a chamber for containing a quantity of fluid to be heated, the chamber having a fluid inlet and a fluid outlet spaced apart in a first axial direction; and means for heating the fluid in said chamber, the heating means  
10 being located in said chamber between said fluid inlet and fluid outlet, the heating means comprises a hollow body having a flow inlet and a return outlet to allow a heating medium to flow through said hollow body, wherein said hollow body comprises a first heat exchanging surface extending along the chamber in, or substantially in, said first axial direction between said fluid inlet and said fluid  
15 outlet, said first heat exchanging surface facing an internal surface of said chamber to define a passage for said fluid therebetween, said passage extending between said first heat exchanging surface and the body in, or substantially in, said first axial direction. Said internal surface of the chamber may be provided by, for example, the body and/or by the surface of another object inside the chamber, for  
20 example another part of the hollow body.

In preferred embodiments, said hollow body is a heating exchanging element, i.e. a part of a heat exchanger for carrying a heating medium.

25 A second aspect of the invention provides a heating system comprising a storage tank for a fluid; and an apparatus for heating said fluid, said heating apparatus including a chamber for containing a quantity of said fluid and means for heating the fluid in said chamber, wherein said apparatus has a fluid outlet provided at the in use top end of the chamber and which is in fluid communication with an in-use  
30 upper portion of said tank, and a fluid inlet provided at or adjacent a lower end of said chamber and which is in fluid communication with an in-use lower portion of said tank, said fluid communication being substantially unrestricted to allow

thermosyphonic flow of fluid between the storage tank and the apparatus during use.

5 In some embodiments, the heating apparatus is provided externally of the storage tank, preferably at a side of the storage tank. In other embodiments, the heating apparatus may be provided internally of the storage tank. Preferably, the heating apparatus provided in the heating system embodies the first aspect of the invention.

10 A further aspect of the invention provides a heating system comprising a storage tank for a fluid; and an apparatus for heating said fluid, said heating apparatus including a chamber for containing a quantity of said fluid and means for heating the fluid in said chamber, wherein an in-use upper portion of said chamber is in, or capable of, fluid communication with an in-use upper portion of said tank, and an  
15 in-use lower portion of said chamber is in, or capable of, fluid communication with an in-use lower portion of said tank.

During use, fluid heated in said chamber rises to the upper portion of the chamber and fluid is drawn into the lower portion from the storage tank. The heated fluid is  
20 drawn from the upper portion of the chamber and is deposited in the upper portion of the storage tank.

Preferably, said heating means comprises a heating device located wholly or partially within said chamber. More preferably, said heating device substantially  
25 fills said chamber. In preferred embodiments, said heating device comprises a heat exchanger, especially a double pass heat exchanger.

Advantageously, the system includes or is connectable to a device for generating renewable energy, e.g. a solar energy collecting device. In the preferred  
30 embodiment, the heating device is connectable to one or more solar energy collecting devices such that the heating medium carried by the heating device is heated by solar energy.

The apparatus and systems are particularly suited for use as a water heating system for buildings, including domestic or commercial buildings. In such cases, said fluid comprises water. The water heating system may form part of a water  
5 dispensing system (e.g. including taps, showers and/or other outlets) and/or may form part of a central heating system.

Accordingly, another aspect of the invention provides a water heating system for buildings, the water heating system comprising the system of the first aspect of the  
10 invention.

A still further aspect of the invention comprises a fluid heating apparatus for connection to a fluid storage tank, the apparatus comprising a chamber for containing a quantity of said fluid and means for heating the fluid in said chamber,  
15 wherein the apparatus is connectable to the storage tank such that an in-use upper portion of said chamber is capable of fluid communication with an in-use upper portion of said tank and an in-use lower portion of said chamber is capable of fluid communication with an in-use lower portion of said tank.

20 In preferred embodiments, the heating apparatus are advantageously arranged to cause a thermosiphonic action in the fluid and may be referred to as thermosyphons.

Advantages of the preferred embodiments include: the water within the heating  
25 system is heated quickly and efficiently; the availability of hot water in the heating system is improved; and when converting an existing heating system, the existing storage tank does not have to be removed and the likelihood of the existing heating system being upset is reduced.

30 Further advantageous aspects of the invention will become apparent to those ordinarily skilled in the art upon review of the following description of a specific embodiment and with reference to the accompanying drawings.

### **Brief Description of the Drawings**

Embodiments of the invention are now described by way of example and with  
5 reference to the accompanying drawings in which like numerals are used to  
indicate like parts and in which:

FIGURE 1 is a schematic diagram of a heating system embodying one aspect of  
the invention;

10

FIGURE 2 is a cross sectional side view of a heating apparatus included in the  
system of Figure 1 and embodying a further aspect of the invention;

FIGURE 3 is a perspective view of the heating apparatus of Figure 2;

15

FIGURE 4 is a perspective view of a tank and heating apparatus assembly  
embodying another aspect of the invention; and

FIGURE 5 is a sectioned side view of the assembly of Figure 4.

20

### **Detailed Description of the Drawings**

Referring now to Figure 1 of the drawings, there is shown, generally indicated as  
10, a preferred heating system embodying one aspect of the invention. The  
25 heating system 10 comprises a first liquid storage tank 14 and a heating apparatus  
12, interconnected by pipework 18. In the preferred embodiment Figure 1, the  
heating system 10 comprises a water heating system for a building, such as a  
domestic or commercial building. Hence, the system 10 stores, heats and delivers  
water. In the following description, the preferred embodiment of a water heating  
30 system is described, although it will be understood that the invention is not limited  
to use with water.

In preferred embodiments, the heating apparatus 12 embodies a further aspect of the invention, and preferably comprises a thermosyphon apparatus, or heat exchanger. The apparatus 12 comprises a body or housing 25 defining an internal chamber 26. In use, the chamber 26 holds a quantity of a heating medium, typically water. In a preferred embodiment, the housing 25 is elongate in shape having first and second ends 28, 30, the first end 28, being positioned above the second end 30 in use. The housing 25 has a longitudinal axis which is, typically, substantially vertically orientated in use. The housing 25 may be manufactured from any suitable material, e.g. copper, and its exterior surface is preferably substantially covered by insulating material 62 (shown in Figures 2 and 3), e.g. a conventional insulating jacket or other insulating covering. In the illustrated embodiment, the housing 25 is substantially cylindrical in shape, but may take alternative cross-sectional shapes.

The storage tank 14 has an internal chamber 20 which, in use, is substantially filled with a heating medium, typically water. The tank 14 has first and second ends 22, 24, the first end 22 being, in use, positioned above the second end 24. In use, the longitudinal axis of the tank 14 is, typically, substantially vertically orientated. The tank 14 may be substantially similar to a typical water storage tank or cylinder used in a conventional water heating system, and is preferably insulated (not illustrated) by a conventional insulating jacket or other insulating cover. The liquid capacity of the chamber 26 is less than the liquid capacity of the chamber 20.

The pipework 18 includes an outlet pipe 40 and inlet pipe 42 connected between the heating apparatus 12 and tank 14. In use, water flows from the housing 25 to the tank 14 via the outlet pipe 40, while the inlet pipe 42 allows water to flow from the tank 14 to the housing 25. More specifically, in the preferred embodiment, the outlet pipe 40 is connected (directly or indirectly) between the first end 28 of the housing 25 and the first end 22 of the tank 14 such that, in use, water located at or near the first end 28 of the chamber 26 can flow to into the chamber 20 at or near the first end 22. As shown in Figure 1, additional pipe sections, e.g. pipe 36, may

be present in the pipework 18, as is necessary or convenient, to create the desired liquid communication in the system 10. The inlet pipe 42 is connected to the tank 14 at or near the second end 24, and to the housing 25 at or near the second end 30 such that, in use, water located at or near the second end 24 of the tank 14 can  
5 flow into the chamber 20 at or near the second end 30. To this end, the housing 25 has an inlet at end 30 which may be referred to as the secondary flow inlet, or the cold feed inlet.

The heating system 10 comprises at least one delivery pipe 44 for delivering the  
10 contents of the tank 14 to one or more outlets, for example taps (not shown). The delivery pipe 44 is connected, directly or indirectly, to the in use upper end 22 of the tank 14 so that water located at or near the end 22 may be drawn out of the tank 14 and dispensed from the system 10. In the illustrated embodiment the delivery pipe 44 is connected to the secondary outlet pipe 36, described  
15 hereinafter.

The illustrated system 10 also includes a second liquid storage tank 32 defining chamber 34. The tank 32 may be substantially similar to a conventional cistern as used in a conventional water heating system and is typically connected to a mains  
20 water supply (not shown). The tank 32 (usually referred to as the cold water tank) may supply (cold) water to the tank 14 (usually referred to as the hot water tank) as required.

In the illustrated embodiment, the pipework 18 includes pipe 36 by which liquid  
25 may enter or leave the tank 14, and inlet pipe 38, by which water may be fed into the tank 14 from the cistern 32. Inlet pipe 38 is connected to the tank 14 at or near the second end 24 such that, in use, water from tank 32 may be fed to the tank 14 at or near the second end 24. A vent pipe 19 is also provided to vent any excess steam or vapour pressure that may build up in the tank 14. The vent 19 may be  
30 directed into the cistern 32.

The heating apparatus 12 comprises means for heating water that is contained within the chamber 26. In the preferred embodiment, the heating means takes the form of a heat exchanger, as is described in more detail hereinafter with reference to Figures 2 and 3, although it may take any other suitable form, for example an electrical immersion heating element. A suitable heat exchanger typically comprises one or more pipes or coils wholly or partially immersed in the water, or other medium, to be heated. The pipes or coils carry a heating medium (typically water, although other liquids/fluids may be used) which is heated during use by a convenient energy source. The heated medium imparts thermal energy to the surrounding water via the walls of the pipes or coils and so heats the surrounding water. When a heat exchanger is used, the system 10 requires an external energy source which, in preferred embodiments, comprises a renewable energy source, especially a solar energy source. Alternatively, any other heat or energy source may be used, e.g. an oil or gas fired boiler, or wood pellet boiler, wind turbine powered heater, and so on.

Hence, in preferred embodiments, the system 10 includes one or more solar energy device 46 for collecting solar energy and converting same into thermal energy. The solar energy device(s) 46 may be of any suitable conventional design. Typically, the, or each, solar energy device 46 (commonly referred to as a solar panel) comprises one or more solar thermal collectors (not shown) and one or more pipes or coils (not shown) carrying a heating medium (typically water, although other fluids may be used). The device 46 typically operates as a heat exchanger whereby the collected solar thermal energy heats the heating medium through the associated pipes or coils. The or each solar panel 46 includes a flow port 47 and a return port 49 by which the heating medium may flow between the solar panel 46 and the heating apparatus 12. To this end, Figure 1 shows flow and return pipes 51, 50 connected between the solar panel 46 and the heating device 46.

The preferred configuration of the heating apparatus 12 is now described in more detail with reference to Figures 2 and 3. The heating means includes a heating

device or element, which is generally indicated as 16 in Figures 2 and 3, and which serves as part of the heat exchanger. The heating element 16 comprises a hollow body containing, in use, a heating medium (assumed to be water in the present example but may comprise other fluid(s)). The heating element 16 has in  
5 inlet 55 connected in use to the flow pipe 51 of the solar panel 46 and an outlet 57 connected in use to the return pipe 50 of the solar panel 46. The inlet 55 may be referred to as a primary flow inlet and receives, in use, a primary flow of a heated medium from the solar panel 46, or other source. The outlet 57 may be referred to as a primary return outlet and returns, in use, a primary return of the heated  
10 medium to the solar panel 46, or other heating source.

In the preferred embodiment, the hollow body of the heating element 16 comprises an inner section in the form of a pipe or tube 54 and an annular or sleeve-like outer section 58 located around substantially all or part of the inner section 54. Each  
15 section 54, 58 is hollow to define a respective internal channel 56, 60 and the sections 54, 58 are connected so that the channels 56, 60 are in fluid communication with one another. Preferably, the inner section 54 is connected to the outer section at or adjacent the end of the outer section 58 so that the inner section 54 extends along substantially the entire length of the outer section 58.  
20 Conveniently, the inlet and outlet 55, 57 of the heating element 16 are each connected to or provided on one or other of the sections 54, 58. In the illustrated embodiment, the inlet 55 is provided by an end 61 of pipe section 54, and the outlet 57 is provided by a pipe or other conduit provided at an outlet of the annular section 58. The preferred heat exchanger is a "double pass" heat exchanger, the  
25 inner section 54 providing a first or inner pass, while the outer section 58 provides a second or outer pass. An end portion of the apparatus 12 may be removable, e.g. by screw fit, to allow maintenance of the apparatus 12. Typically, the removable portion is provided at end 28.

30 The heating element 16 is located in chamber 26 and is preferably dimensioned to substantially fill the chamber 26, at least transversely but preferably also longitudinally. The external surfaces of the heating element 16 serve as heat

exchanging surfaces. The outer external surface of the heating element 16 (provided in the present example by the annular section 58) faces the internal surface of the housing 25 to define an annular passage 35 therebetween along which fluid may pass when travelling from the inlet to the outlet of the chamber 26. The width of the passage 35 is relatively small, for example about 5mm. A second fluid passage 37 is defined between the inner external surface of the annular section 58 and the external surface of the inner pipe 54. The arrangement is such that when the chamber 26 is filled with water, the water surrounds the heating element 16 and is in contact with its heat exchanging surfaces 48 as provided by the inner and outer surfaces of the annular section 58 and the outer surface of the inner pipe 54. To this end, the sections 54, 58 are formed from a suitable heat conducting material, for example copper. The preferred configuration of heat exchanger described above offers a relatively large surface area by which heat exchange can take place. Moreover, because the heating element substantially fills the chamber 26, or at least a portion of the chamber 26, there is a relatively small volume of water in the chamber 26, a large proportion of which is in contact with, or is close to, the surfaces of the sections 54, 58 and this allows that heating element 16 to heat the water in chamber 26 relatively quickly.

In alternative embodiments (not illustrated) one or more fluid passages maybe defined between any two or more surfaces within the chamber 26, at least one of which is a heat exchanging surface.

In use, the heating medium circulates between the solar panel(s) 46 and the heating element 16 via the primary flow and return pipes 51, 50. A pump control unit 68 may be provided to cause or assist the circulation. The heating medium is heated by solar energy when at the solar panel(s) 46 and heats the water in chamber 26 when in the heat exchanger. Since water has different densities at different temperatures, a temperature gradient forms within the chamber 26. The water in the chamber 26 thus moves upwards towards the first end 28 of the housing 25, being heated by the heating element 16 as it travels, colder water gathering at the second end 30 of the chamber 25. The rise of the heated water in

the chamber 26 causes water to be drawn into the bottom 30 of the chamber 26 from the bottom 24 of tank 14 via pipe 42. Normally, this water is cold or cooler water that has gathered at the bottom of the tank 14. Because the top 28 of the chamber 26 is in fluid or liquid communication with the top 22 of the tank 14, the drawing of water from the tank 14 into the chamber 26 via pipe 42 causes the heated water at the top 22 of the chamber 26 to be drawn into the top 22 of the tank 14 (via pipes 40 and 36 in the present example). This action, which is effected by gravity and convection, may be referred to as thermosyphonic action and the heat exchanger 12 may be described as a thermosyphon apparatus.

10

To promote the thermosyphonic effect, it is advantageous to maximise the gravity based pressure differential in the thermosyphon circuit. It is preferred, therefore, that the connection between the in use lower end 30 of the apparatus 12 and the tank 14 is located at or adjacent the in use lower end of the tank 14. It is also preferred that the inlet 37 of the tank 14 through which heated water is delivered from the heating apparatus 12 is located in the in use top, and in particular through the top end surface, of the tank 14. The preferred arrangement is such that the water from the apparatus 12 is delivered into the top of the tank 14 from above the tank 14. Typically, the water is delivered into the top of the tank 14 by a pipe or other conduit (pipe 36 in the illustrated example) that extends from the top of the tank 14 in a direction that is, in use, upwards. In the illustrated example, a section of pipe 40 also extends in use upwardly from the top of apparatus 12, the pipes 36, 40 connecting at point P which is the highest point in the thermosyphon circuit. In the illustrated example, the pressure differential in the thermosyphon circuit is determined by the vertical distance between point P and the inlet 42. Typically, this distance is approximately 2000mm. For typical sizes of tank 14, point P may be approximately 500mm above the top of the tank 14. It will be understood that the connection between the top of the apparatus 12 and the top of the tank 14 may be made using one or more pipes or conduits as desired, preferably including a section extending in use substantially upwards from the tank 14, and/or preferably a section extending in use substantially upwards from the apparatus 12. It will be understood that, depending on the respective heights of the tank 14 and apparatus

12, one or both of the upwardly extending sections of the pipework 36, 40 may not be required, and the feed into the top of the tank 40 may be made at a side wall of the tank.

5 It is noted that in the thermosyphon circuit, which in the illustrated example includes the chamber 26, the pipes 36, 40, the chamber 20 and the inlet pipe 42, no valves or pumps are present – the water travels around the circuit under the thermosyphon effect. Therefore, the apparatus 12, does not have any valves or other fluid control devices at, or in the path of, its secondary inlet and outlet.

10

Hence, the heated water which leaves the heating apparatus 12 via the outlet pipe 40 is deposited within the tank 14 at or near the first end 22. This deposition of relatively hot water into the in use top of the tank 14 results in a layering of water in the tank 14 whereby hotter water sits at or near the top 22 of the tank 14 and cooler water is located at or near the bottom 24.

15

When one or more of the system's outlets (e.g. taps or showers) is operated, water is drawn from the top 22 of the tank 14 via pipe 44 and delivered to the tap, shower or other outlet. When water is dispensed from the system 10, the water in the tank 14 may be replenished from the cistern 32 via pipe 38. The configuration of the system 10 as described above increases the probability that hot water is available for delivery from the tank 14. This is because a relatively small quantity of water can be heated quickly and efficiently in the heating apparatus 12 and then deposited into the top 22 of the tank 14 so that it is available to users of the system 10 without having to migrate upwardly through, or be diluted by, the colder water in the tank 14.

20

25

By way of example, the housing 25 is approximately 800 mm in length and approximately 65 mm in width. The pipes 50, 51 40, 42 may be approximately 15 mm diameter. Preferably, the outlet pipe 40 is connected to the secondary outlet pipe 36 at a height of approximately 600mm above the housing 25. The inner section 54 may be approximately 15mm diameter and the annular section 58 may

30

have an outer diameter of approximately 54 mm and an inner diameter of approximately 42mm giving an internal chamber width of approximately 12mm.

In preferred embodiments, at least some and preferably all of the internal surfaces of the heating apparatus 12 are substantially smooth. In particular, it is preferred that the internal walls of chamber 26, the external surfaces of the annular section 58 and/or the outer surfaces of the inner section 54 are smooth. It is preferred the some or all of the aforesaid internal surfaces are substantially solid or continuous, and preferably also substantially straight, at least in a direction longitudinal of the apparatus 12. This end, the outer section of the heating element 16 is preferably comprises a sleeve formed by a hollow wall with substantially straight and continuous external surfaces extending in the longitudinal direction. In the illustrated embodiment, the sleeve 58 is substantially circular in transverse cross-section (i.e. in a plane perpendicular with the longitudinal axis of the apparatus 12) and so is substantially cylindrical in shape, although in alternative embodiments it may take any one of a variety of alternative transverse cross-sectional shapes, e.g. rectangular or polygonal. The size or width of the section 58 may be substantially constant in transverse cross-section (taken in a plane perpendicular with the longitudinal axis of the apparatus 12). Similarly, the inner section 54 preferably comprises a substantially linear tube with substantially straight and continuous external surfaces extending in the longitudinal direction, and maybe said to be of substantially constant transverse cross-section.

In the illustrated embodiment, the heat exchanger 12 has a double pass arrangement implemented by the provision and interconnection of the inner and outer sections 54, 58. The inner section 54 is located within, and spaced-apart from, the outer section 58 with their respective longitudinal axis running substantially parallel or coincident with one another. The inner section 54 enters the outer section 58 at one end and is connected to it preferably at the other end. In alternative embodiments, one or other of the sections 54, 58 may be omitted, and/or alternative shapes and configurations for the heating element 16 may be used. For example, with the inner section 54 omitted, the primary flow and return

conduits 51, 50 may each be connected to the outer section 58. The channel 60 within the outer section 58 may be configured to provide one or more passes along its length between the primary flow inlet and primary return outlet. Depending on how many passes are provided, the return conduit 50 may be located at the same  
5 or opposite end of the section 58, and therefore of the apparatus 12, as the inlet 51.

The smooth and continuous nature of the surfaces within the heat exchanger 16 creates relatively low frictional losses for the secondary water flowing through the chamber 26. This promotes a relatively smooth and efficient flow of the  
10 secondary water and this facilitates the thermosyphonic action.

To further facilitate the thermosyphonic action, it is preferred that the secondary flow outlet from the apparatus 12 (which in the present example is implemented by pipe 40) is arranged to provide a channel for the secondary flow out of the  
15 chamber 26 that extends substantially linearly from the end 28 of the apparatus 12 in the longitudinal direction. To this end, the preferred apparatus 12 has a secondary outlet 41 from the chamber 26, the outlet 41 being located at the end 28 and more particularly in the end face 29 of the chamber 29 so that water flowing through the outlet 41 flows in the longitudinal direction. The outlet pipe 40, when  
20 connected to the outlet 41 extends from the end of apparatus 12 in the longitudinal direction. The arrangement is such that, in use, water flowing upwardly through the chamber 26 exits the chamber 26 from the top of the apparatus 12 and so flows substantially linearly in the upwards direction and is not impeded by, for example, a bend in the pipework.

25 Advantageously, the diameter of the outlet 41, and preferably also the outlet pipe 40, is selected to create a venturi effect in chamber 26 in the region of the outlet 41 and this helps to promote the flow of water out of the chamber 26.

30 In preferred embodiments, the apparatus 12 is arranged such that each of the pipes 40, 50, 51 is connectable to the same end, in particular the in use top end, of the

apparatus 12. However, in alternative embodiments, one or more of the pipes may be connectable to the other end, or elsewhere on the apparatus 12.

Optionally, one or more additional, or alternative, heating elements, e.g. an electrical immersion heater (not shown) or other electrically powered heating device, may be provided in the chamber 26, 126, typically at the in use lower end 30. Advantageously, the heating element may be powered by a renewable energy source, for example a wind turbine. For example, a wind turbine (not shown) may be electrically coupled to an electrical immersion heater, or other electrically powered heating device, located in the chamber 26, 126. It is envisaged that such heating devices are provided in addition to the heat exchanging units 16, 116 described above, although they could alternatively be provided in the chamber 26, 126 instead of the units 16, 116.

The system 10 shown in Figure 1 is suitable for use as a typical domestic open vented water supply system. It will be understood that the invention is not limited to use with such systems. For example, the invention may be used with a direct mains fed pressurised plumbing system (not illustrated). Such systems do not require the cistern 32 or the open vent 19.

Moreover, the system 10 may be used not only with a dispensing hot water system, but also with a central heating system in which the heated water is delivered to heating units such as radiators.

It is noted that the system 10, in particular the interaction between the heating apparatus 12 and the tank 14, does not require any valves, pumps or electrical connections. It is preferred, for reasons of safety that no valves are fitted to the circulating pipework 18 between the heating apparatus 12 and the tank 14. This allows the water in the chamber 26 of the apparatus 12 to expand freely as it is heated. The flow and return pipes 51, 50 may include one or more isolating valves at the pump control unit 68, and typically also a regulator, with which to adjust the flow rate of the circuit between the solar panel 46 and the heating apparatus 12.

Referring now to Figures 4 and 5, there is shown a combined tank and heating apparatus, generally indicated as 70, embodying a further aspect of the invention. The tank 114 is typically a liquid (usually water) storage tank of the type suitable for use in a water heating system. The heating apparatus 112 may be substantially similar to the heating apparatus 12 and variations thereof described hereinbefore and so like numerals are used to indicate like parts and similar descriptions apply as will be apparent to the skilled person.

10 The heating apparatus 112 is located within the chamber 120 of the tank 114. The respective longitudinal axes of the tank 114 and apparatus 112 are preferably substantially coaxial or parallel. The primary flow inlet 155 and primary return outlet 157 are connected to conduits 151, 150 extending through the wall of the tank 114, preferably through the in use top of the tank 114. The secondary flow  
15 outlet 141 from the chamber 126 opens into the chamber 120. The apparatus 112 is preferably positioned and orientated within the tank such that the outlet 141 opens into the in use top 122 of the chamber 120.

A delivery conduit or pipe 144 is provided for delivering the contents of the tank  
20 114 to remote outlets, e.g. taps (not shown). The inlet 145 to the delivery pipe 144 is preferably located in the top of the tank 114 and more preferably is substantially aligned or in register with the outlet 141 of the apparatus 112 so that, in use, heated water emanating from the outlet 141 may readily flow through the inlet 145. It is preferred, however, that the outlet 141 and inlet 145 are not directly  
25 connected to one another in order to allow heated water to gather in the top of the tank 114.

The secondary inlet, or cold feed, to the apparatus 112 may be provided in any convenient manner at the in use lower end 130 of the housing 125. For example, in  
30 the illustrated embodiment, the housing 125 is open ended to allow water to flow directly from the chamber 120 into the lower end 130 of the chamber 126 under thermosyphonic action.

The combined tank and heating apparatus 70 may be incorporated in to a heating system such as, for example the system shown in Figure 1 in place of tank 14 and thermosyphon 12. The tank 114 has an inlet 139 through which cold water may be provided, e.g. from cistern 34. Delivery pipe 144 may be connected to vent pipe 19 if required.

In use, a heated primary medium, typically water, is passed through the heating device 116 from the solar panel(s), or other heat source, and heats the water in the chamber 26. A thermosyphonic action is created whereby water is drawn into the lower end 130 of chamber 26 from chamber 120, whereupon it is heated as it travels upwardly through the chamber 126 and is then delivered into the top 122 of the tank 144.

The present invention is not limited to the embodiment(s) described herein, which may be amended or modified without departing from the scope of the present invention.

## CLAIMS:

1. A fluid heating apparatus comprising a body defining a chamber for containing a quantity of fluid to be heated, the chamber having a fluid inlet and a fluid outlet spaced apart in a first axial direction; and means for heating the fluid in said chamber, the heating means being located in said chamber between said fluid inlet and fluid outlet, the heating means comprises a hollow body having a flow inlet and a return outlet to allow a heating medium to flow through said hollow body, wherein said hollow body comprises a first heat exchanging surface extending along the chamber in said first axial direction between said fluid inlet and said fluid outlet, said first heat exchanging surface facing an internal surface of said chamber to define a passage for said fluid therebetween, said passage extending in said first axial direction.
2. An apparatus as claimed in claim 1, wherein said first heat exchanging surface and said internal surface of said body are substantially solid, and preferably substantially smooth, along said passage.
3. An apparatus as claimed in claim 1 or 2, wherein said passage is substantially straight in said first axial direction.
4. An apparatus as claimed in any one of claims 1 to 3, wherein said hollow body substantially fills said chamber.
5. An apparatus as claimed in any preceding claim, wherein said passage is substantially annular in a plane perpendicular with said first axial direction.
6. An apparatus as claimed in any preceding claim, wherein the hollow body comprises an annular outer section, said first heat exchanging surface being provided by an outer external surface of said annular outer section.

7. An apparatus as claimed in claim 6, wherein said annular outer section is sleeve shaped, and preferably substantially cylindrical in shape.
8. An apparatus as claimed in claim 6 or 7, wherein the annular outer section has  
5 an inner external surface, the inner external surface providing a second heat exchanging surface extending between said fluid inlet and said fluid outlet.
9. An apparatus as claimed in any one of claims 6 to 8, wherein the hollow body includes a hollow inner section located within, and in fluid communication with,  
10 said annular outer section and having an outer surface, said outer surface providing a third heat exchanging surface extending between said fluid inlet and said fluid outlet.
10. An apparatus as claimed in any preceding claim, wherein the or each heat  
15 exchanging surface is substantially solid and preferably substantially smooth.
11. An apparatus as claimed in claim 9 or 10, wherein said inner section comprises a pipe.
12. An apparatus as claimed in any one of claims 9 to 11, wherein said inner  
20 section has a longitudinal axis that is substantially parallel with, and preferably substantially coaxial with, the longitudinal axis of the outer section.
13. An apparatus as claimed in any one of claims 9 to 12, wherein a second fluid  
25 passage is defined between the outer surface of the inner section and the inner surface of the annular outer section, said second passage being substantially straight in said axial direction.
14. An apparatus as claimed in any one of claims 9 to 13, wherein said flow inlet  
30 is provided on one or other of said inner or outer hollow body sections, the return outlet being provided on the other of said inner or outer hollow body sections.

15. An apparatus as claimed in claim 14, wherein inner section is connected to said outer section at one end of the outer section, said flow inlet or return outlet being provided on the opposite end of the outer section, the other of said flow inlet or return outlet preferably being provided on the inner section adjacent said  
5 opposite end of the outer section.

16. An apparatus as claimed in any preceding claim, wherein said flow inlet and return outlet are provided at the same end of the apparatus, preferably the in use top end of the apparatus.  
10

17. An apparatus as claimed in any preceding claim, wherein said fluid outlet is provided at the in use top end of the apparatus and is substantially aligned with said first axial direction, and is preferably substantially aligned with at least part of said fluid passage.  
15

18. An apparatus as claimed in claim 17, wherein said fluid outlet includes a fluid conduit extending from said apparatus in a direction substantially parallel with, or substantially coincident with, said first axial direction.

19. An apparatus as claimed in any preceding claim, wherein said fluid inlet is provided at or adjacent the in use lower end of the apparatus.  
20

20. An apparatus as claimed in any preceding claim, wherein said body is substantially cylindrical in shape.  
25

21. An apparatus as claimed in any preceding claim, wherein said apparatus is in fluid communication with a storage tank having an in use upper portion and an in use lower portion, wherein said fluid outlet is provided at the in use top end of the apparatus and is in fluid communication with said in-use upper portion of said  
30 tank, and said fluid inlet is provided at or adjacent a lower end of said apparatus and is in fluid communication with said in-use lower portion of said tank, said

fluid communication being substantially unrestricted to allow thermosyphonic flow of fluid between the storage tank and the apparatus during use.

5 22. An apparatus as claimed in claim 21, wherein said apparatus is located externally of the tank, preferably adjacent a side of the tank.

23. An apparatus as claimed in claim 22, connected to said storage tank by a fluid conduit including a delivery section for delivering fluid into said upper portion of the tank, wherein said delivery section is arranged to deliver said fluid from above  
10 the tank in use, preferably through the top of the tank.

24. An apparatus as claimed in claim 23, wherein said delivery section extends from the top of the storage tank in a substantially vertical direction in use.

15 25. An apparatus as claimed in any one of claims 22 to 23, connected to said storage tank by a fluid conduit including a section through which fluid is drawn in use from the top of the apparatus, said drawing section extending from said apparatus in a substantially vertical direction in use.

20 26. An apparatus as claimed in claim 21, wherein the apparatus is provided internally of the tank.

27. An apparatus as claimed in claim 26, wherein said fluid outlet opens onto said upper portion of the tank and said fluid inlet opens onto said lower portion of the  
25 tank.

28. An apparatus as claimed in claim 26 or 27, a fluid conduit being connected to the upper portion of the tank, preferably at the top of the tank, for drawing fluid from the upper portion of the tank, and wherein said fluid outlet is substantially  
30 aligned with said fluid conduit.

29. An apparatus as claimed in any preceding claim, wherein said flow inlet and said return outlet are connected to an apparatus for heating said heating medium, preferably a solar energy heating apparatus, or other renewable energy heating apparatus.

5

30. A heating system comprising a storage tank for a fluid; and an apparatus for heating said fluid, said heating apparatus including a chamber for containing a quantity of said fluid and means for heating the fluid in said chamber, wherein said apparatus has a fluid outlet provided at the in use top end of the chamber and  
10 which is in fluid communication with an in use upper portion of said tank, and a fluid inlet provided at or adjacent a lower end of said chamber and which is in fluid communication with an in-use lower portion of said tank, said fluid communication being substantially unrestricted to allow thermosyphonic flow of fluid between the storage tank and the apparatus during use.

15

31. A system as claimed in claim 30, wherein said apparatus is located externally of the tank, preferably adjacent a side of the tank.

32. A system as claimed in claim 31, wherein the apparatus is connected to said  
20 storage tank by a fluid conduit including a delivery section for delivering fluid into said upper portion of the tank, wherein said delivery section is arranged to deliver said fluid from above the tank in use, preferably through the top of the tank.

33. A system as claimed in claim 32, wherein said delivery section extends from  
25 the top of the storage tank in a substantially vertical direction in use.

34. A system as claimed in any one of claims 31 to 33, wherein the apparatus is connected to said storage tank by a fluid conduit including a section through which fluid is drawn in use from the top of the apparatus, said drawing section extending  
30 from said apparatus in a substantially vertical direction in use.

35. A system as claimed in claim 30, wherein the apparatus is provided internally of the tank.

5 36. A system as claimed in claim 35, wherein said fluid outlet opens onto said upper portion of the tank and said fluid inlet opens onto said lower portion of the tank.

10 37. A system as claimed in claim 35 or 36, comprising a fluid conduit connected to the upper portion of the tank, preferably at the top of the tank, for drawing fluid from the upper portion of the tank, and wherein said fluid outlet is substantially aligned with said fluid conduit.

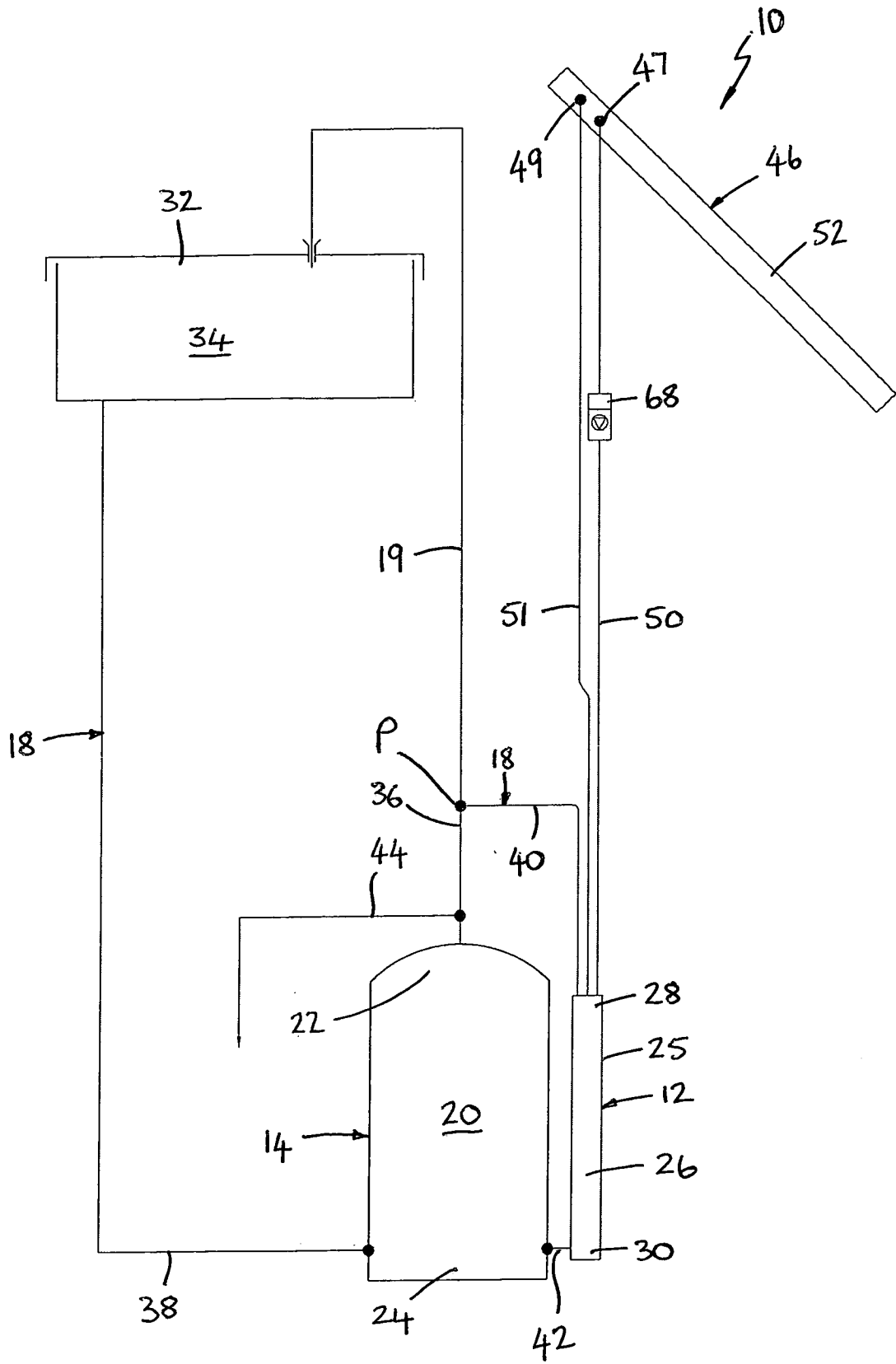

FIG. 1

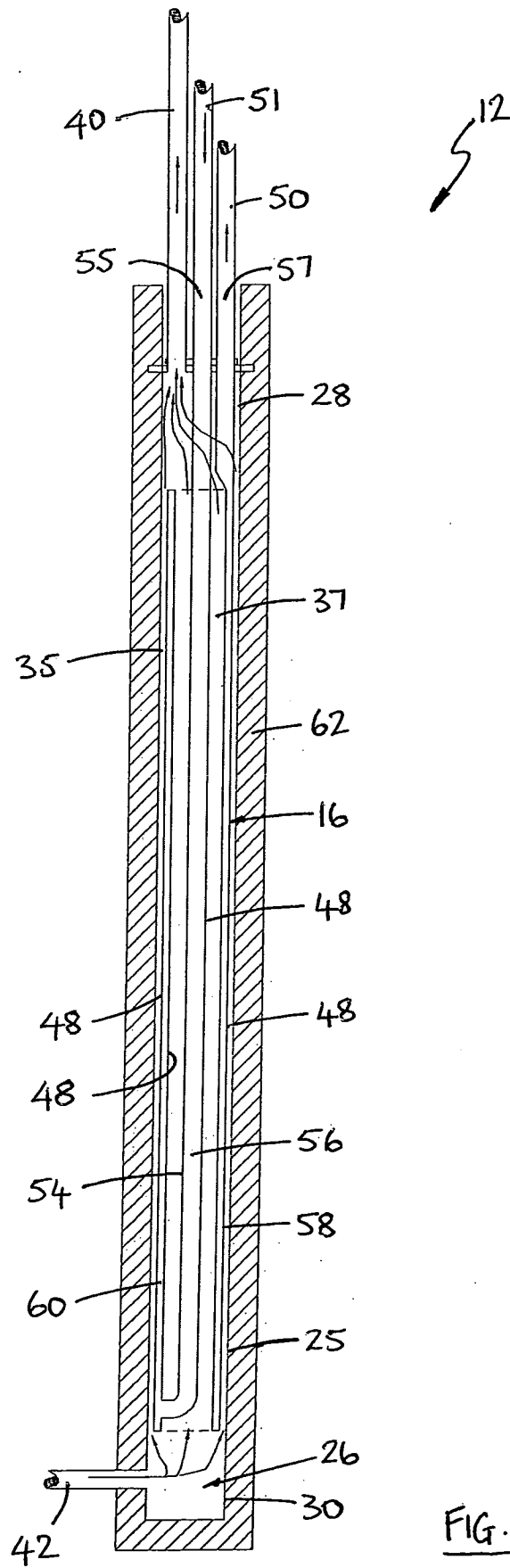

FIG. 2

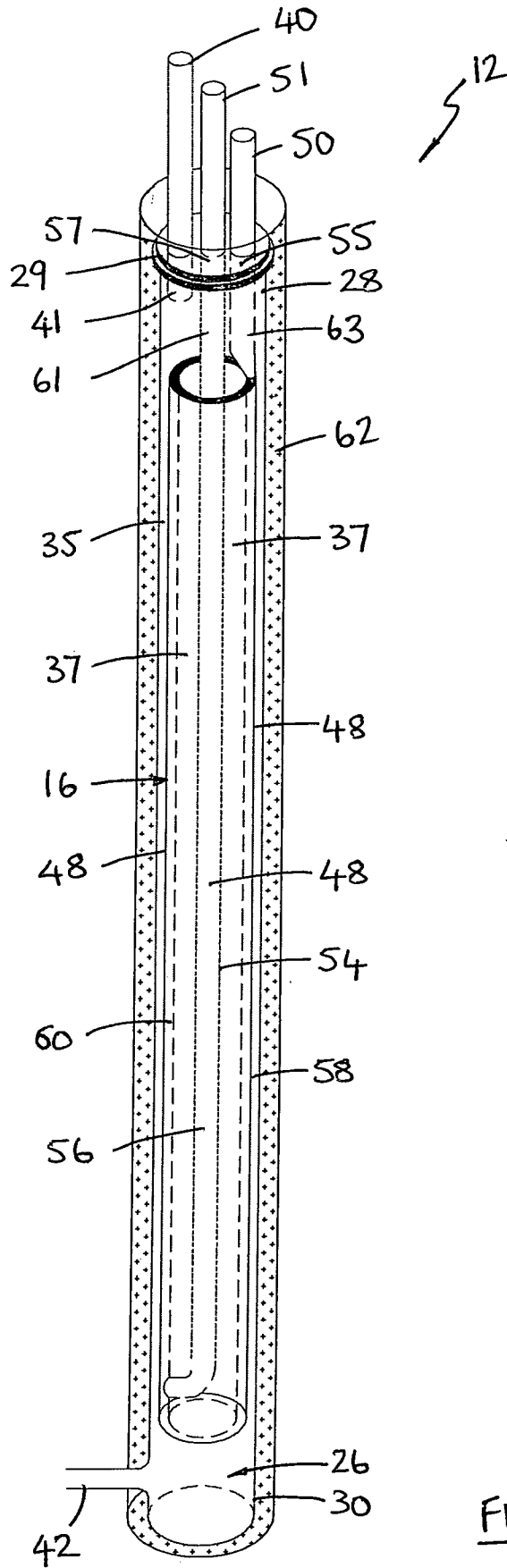

FIG.3

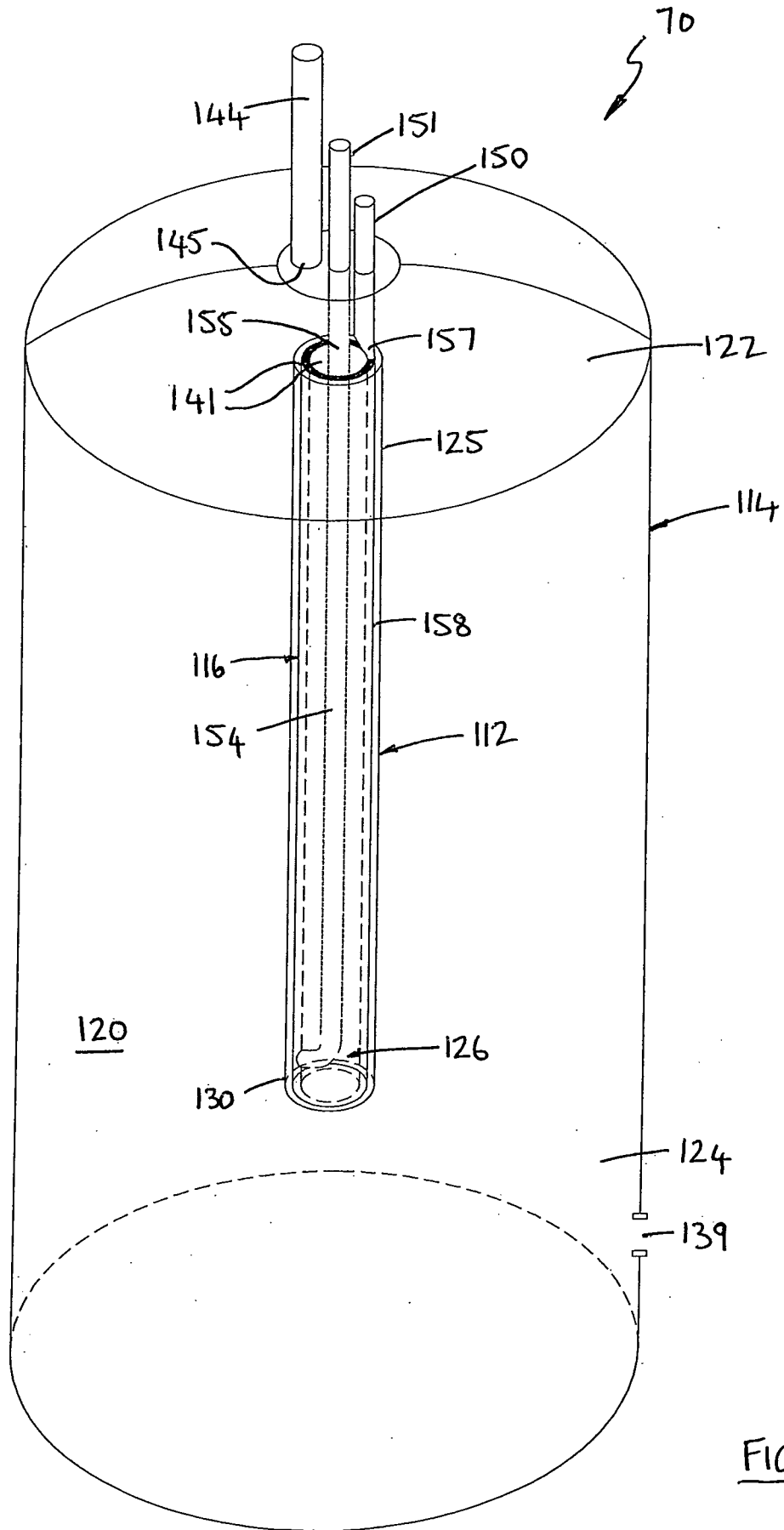

FIG. 4

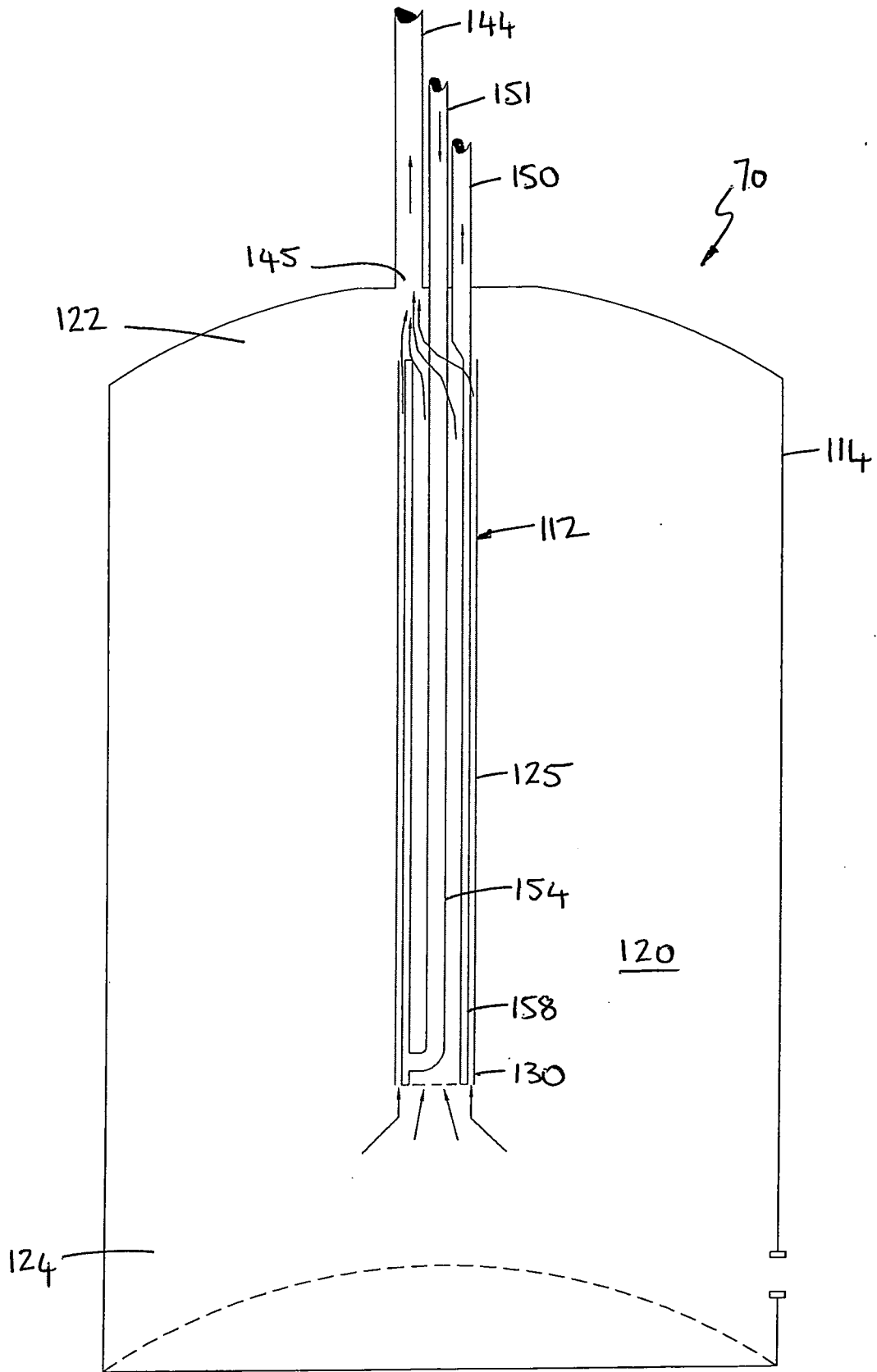

FIG. 5

## INTERNATIONAL SEARCH REPORT

International application No

PCT/EP2007/008915

## A. CLASSIFICATION OF SUBJECT MATTER

INV. F24H1/12 F24H1/20 F28D7/10 F28D7/12 F28D20/00

According to International Patent Classification (IPC) or to both national classification and IPC

## B. FIELDS SEARCHED

Minimum documentation searched (classification system followed by classification symbols)

F24H F28D

Documentation searched other than minimum documentation to the extent that such documents are included in the fields searched

Electronic data base consulted during the international search (name of data base and, where practical, search terms used)

EPO-Internal

## C. DOCUMENTS CONSIDERED TO BE RELEVANT

Category*	Citation of document, with indication, where appropriate, of the relevant passages	Relevant to claim No.
X	US 4 256 059 A (ROGGOW MERVIN A ET AL) 17 March 1981 (1981-03-17)	1-29
Y	column 2; figures 1-3	30-37
X	US 5 357 906 A (BRAZIER DENNIS [US]) 25 October 1994 (1994-10-25) the whole document	1-37
Y	DE 32 26 460 A1 (STIEBEL ELTRON GMBH & CO KG [DE]) 19 January 1984 (1984-01-19) page 4 - page 6; figure 1	30-37
X	FR 2 609 537 A (BARATA CHAUDIERES [FR]) 15 July 1988 (1988-07-15) abstract; figure 1	1-20
	-/--	

 Further documents are listed in the continuation of Box C. See patent family annex.

\* Special categories of cited documents :

- \*A\* document defining the general state of the art which is not considered to be of particular relevance
- \*E\* earlier document but published on or after the international filing date
- \*L\* document which may throw doubts on priority claim(s) or which is cited to establish the publication date of another citation or other special reason (as specified)
- \*O\* document referring to an oral disclosure, use, exhibition or other means
- \*P\* document published prior to the international filing date but later than the priority date claimed

- \*T\* later document published after the international filing date or priority date and not in conflict with the application but cited to understand the principle or theory underlying the invention
- \*X\* document of particular relevance; the claimed invention cannot be considered novel or cannot be considered to involve an inventive step when the document is taken alone
- \*Y\* document of particular relevance; the claimed invention cannot be considered to involve an inventive step when the document is combined with one or more other such documents, such combination being obvious to a person skilled in the art.
- \*&\* document member of the same patent family

Date of the actual completion of the international search

17 January 2008

Date of mailing of the international search report

31/01/2008

Name and mailing address of the ISA/

European Patent Office, P.B. 5818 Patentlaan 2  
NL - 2280 HV Rijswijk  
Tel. (+31-70) 340-2040, Tx. 31 651 epo nl,  
Fax: (+31-70) 340-3016

Authorized officer

GARCIA MONCAYO, O

## INTERNATIONAL SEARCH REPORT

International application No

PCT/EP2007/008915

C(Continuation). DOCUMENTS CONSIDERED TO BE RELEVANT		
Category*	Citation of document, with indication, where appropriate, of the relevant passages	Relevant to claim No.
X	US 2003/159804 A1 (BUTLER BARRY LYNN [US]) 28 August 2003 (2003-08-28) abstract; figure 1 -----	1-3
A	EP 0 194 975 A (GYGER GILBERT [CH]; GROSJEAN MAURICE [CH]) 17 September 1986 (1986-09-17) the whole document -----	1

**INTERNATIONAL SEARCH REPORT**

Information on patent family members

International application No

PCT/EP2007/008915

Patent document cited in search report	Publication date	Patent family member(s)	Publication date
US 4256059	A	17-03-1981	NONE
US 5357906	A	25-10-1994	NONE
DE 3226460	A1	19-01-1984	NONE
FR 2609537	A	15-07-1988	NONE
US 2003159804	A1	28-08-2003	US 2005139344 A1 30-06-2005
EP 0194975	A	17-09-1986	NONE