

(No Model.)

5 Sheets—Sheet 1.

A. D. TYRREL.  
ENVELOPE MACHINE.

No. 452,325.

Patented May 12, 1891.

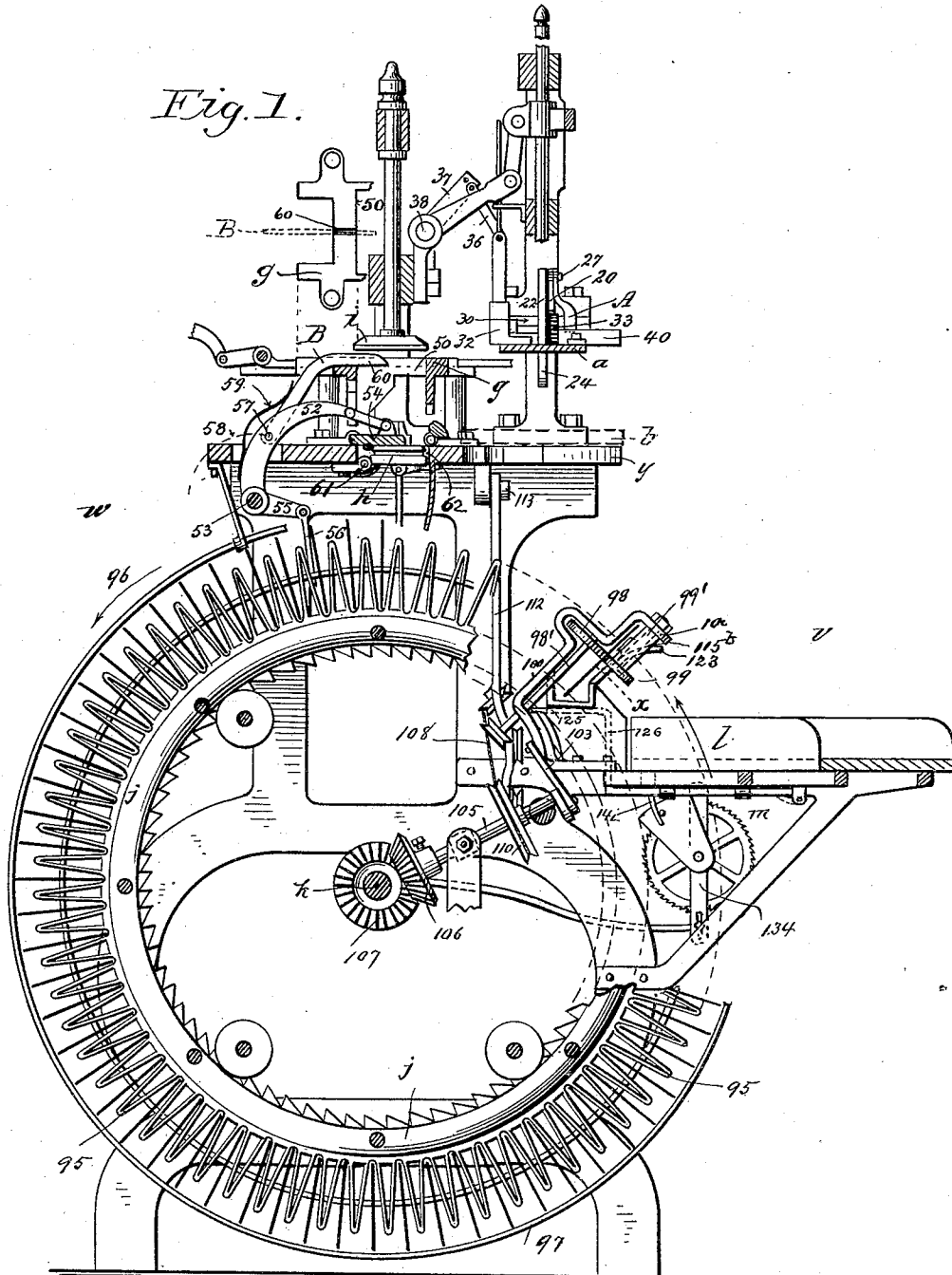

Witnesses:

*J. E. Gougeon*  
*Wm. S. Bellm*

*Inventor*  
*Alvin D. Tyrrel,*  
*by* *Chapin & Co.*  
*Attys.*

(No Model.)

5 Sheets—Sheet 2.

A. D. TYRREL.  
ENVELOPE MACHINE.

No. 452,325.

Patented May 12, 1891.

Fig. 2.

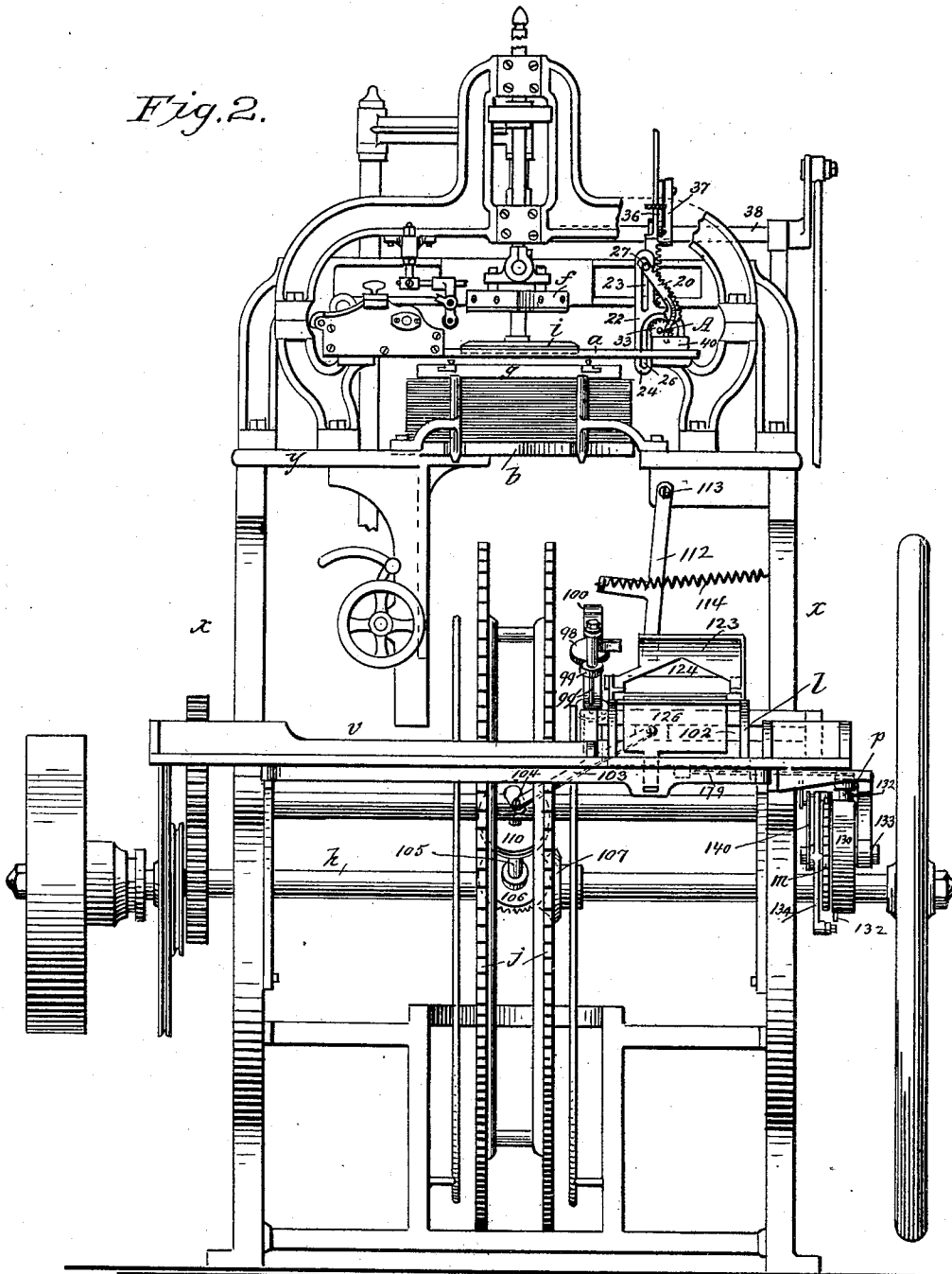

Witnesses:  
*J. H. Garfield*  
*Wm. S. Bellows*

Inventor,  
*Alvin D. Tyrrel*  
 by *Chapin & Co*  
*Attys*

A. D. TYRREL.  
ENVELOPE MACHINE.

No. 452,325.

Patented May 12, 1891.

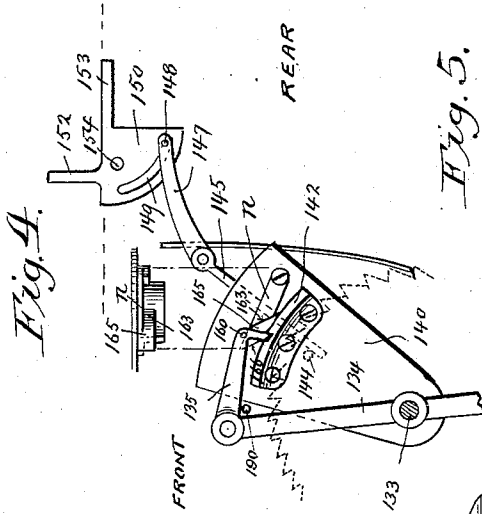

Fig. 4.

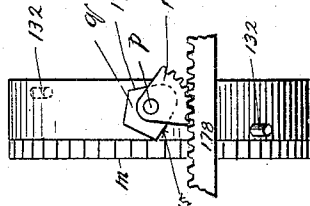

Fig. 5.

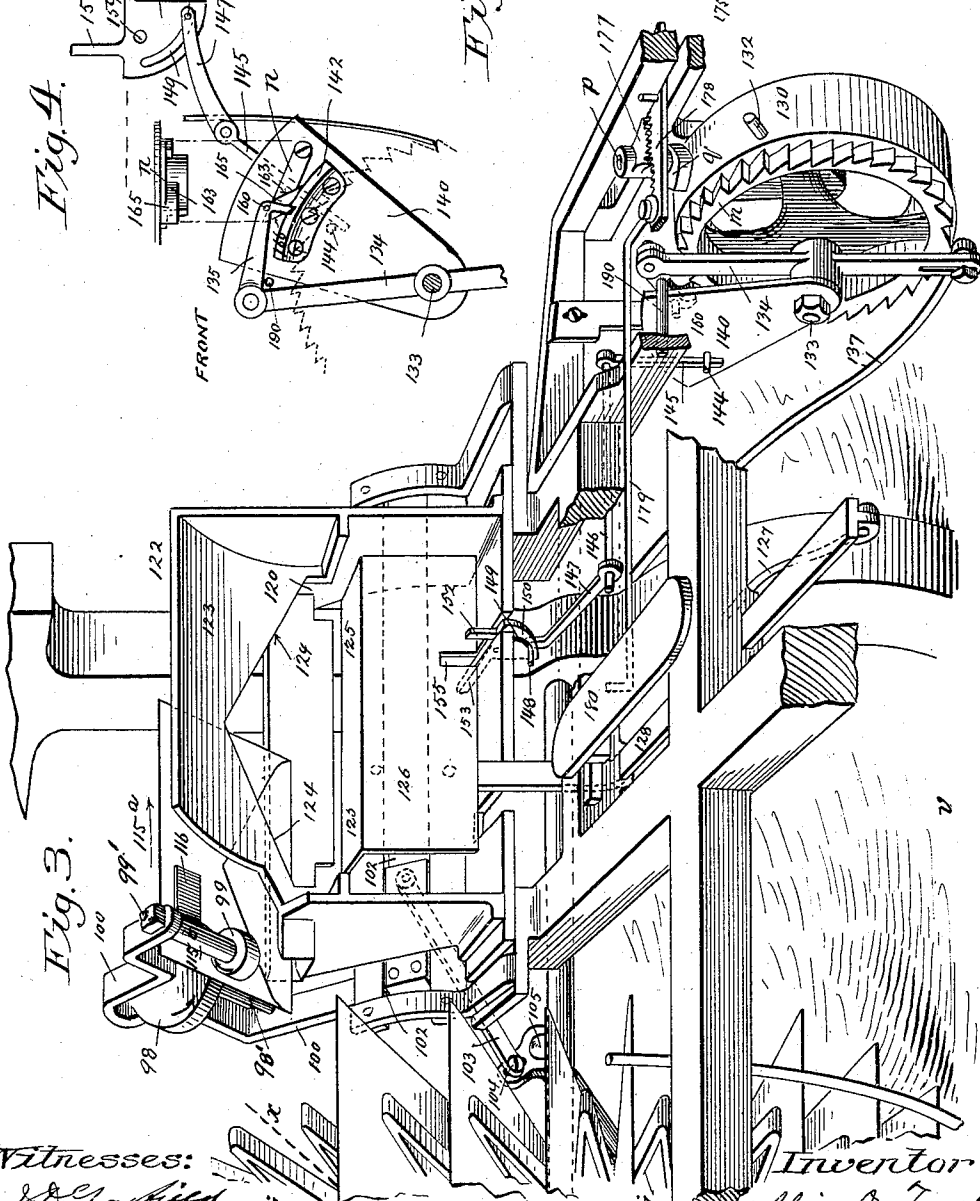

Fig. 3.

Witnesses:  
*J. S. Coffey*  
*W. S. Bell*

Inventor  
 A. D. Tyrrel  
 by *Chapman & Co.*  
 Attys.

(No Model.)

5 Sheets—Sheet 4.

A. D. TYRREL.  
ENVELOPE MACHINE.

No. 452,325.

Patented May 12, 1891.

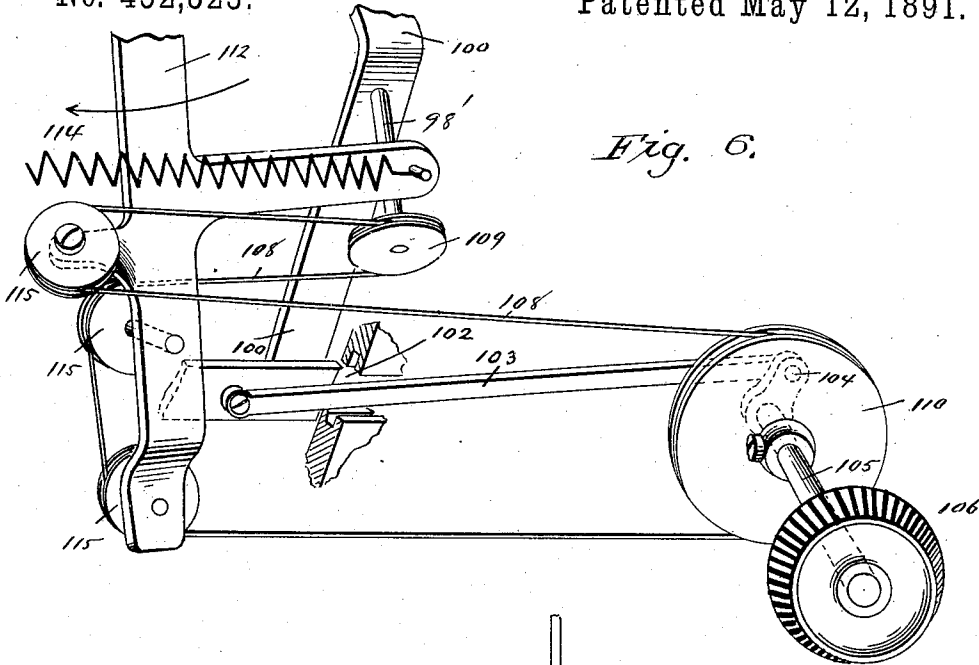

Fig. 6.

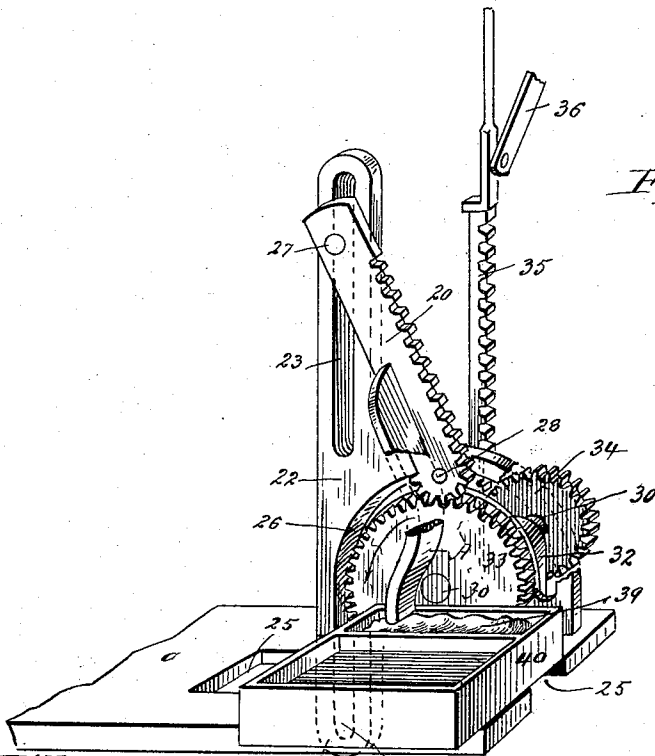

Fig. 7.

Witnesses: 24 26  
*J. S. [Signature]*  
*W. S. [Signature]*

Inventor,  
 A. D. Tyrrel,  
 by *Chapman & Co.*  
*Attys.*

A. D. TYRREL.  
ENVELOPE MACHINE.

No. 452,325.

Patented May 12, 1891.

Fig. 8.

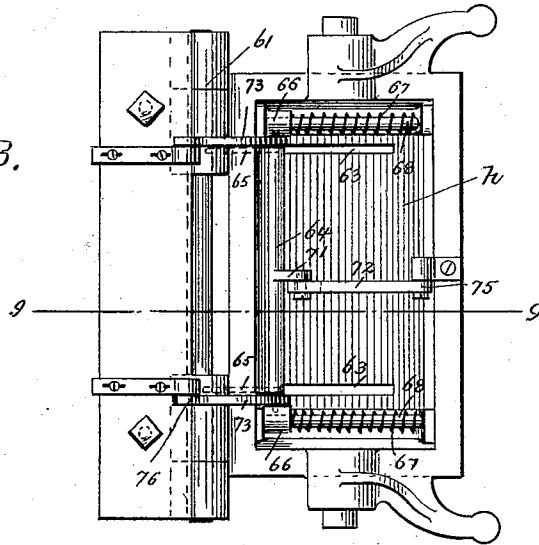

Fig. 9.

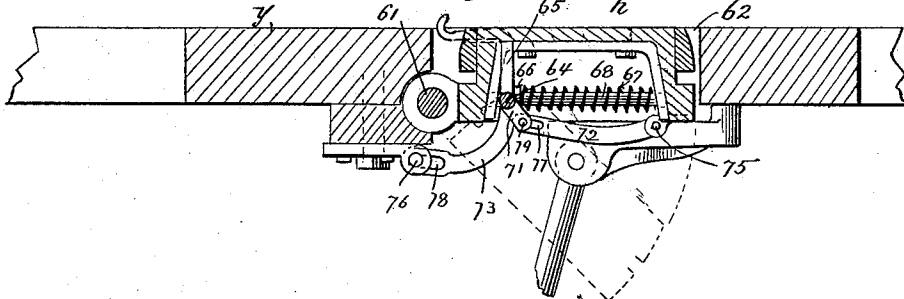

Fig. 10.

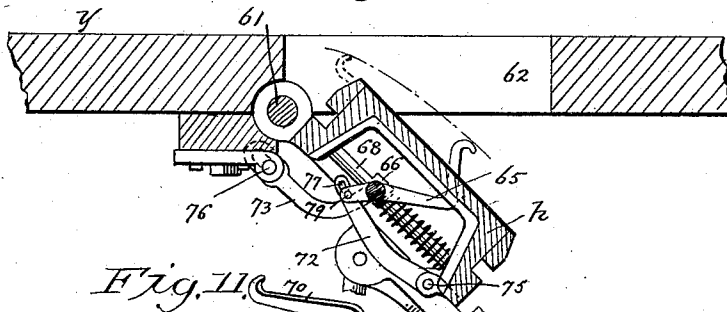
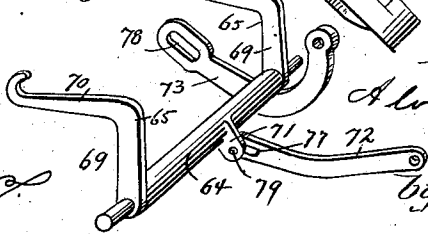

Fig. 11.



Witnesses:

*J. A. Garfield*  
*Wm. S. Bellows*

Inventor  
*Alvin D. Tyrrel*

by *Chapin Co.*  
*Attys*

# UNITED STATES PATENT OFFICE.

ALVIN D. TYRREL, OF SOUTH HADLEY FALLS, ASSIGNOR TO THE HAMPDEN ENVELOPE COMPANY, OF HOLYOKE, MASSACHUSETTS.

## ENVELOPE-MACHINE.

**SPECIFICATION** forming part of Letters Patent No. 452,325, dated May 12, 1891.

Application filed April 18, 1890. Serial No. 348,558. (No model.)

*To all whom it may concern:*

Be it known that I, ALVIN D. TYRREL, a citizen of the United States, residing at South Hadley Falls, in the county of Hampshire and State of Massachusetts, have invented new and useful Improvements in Envelope-Machines, of which the following is a specification.

This invention relates to improvements in envelope-machines. The improvements particularly relate to an end-flap-gummer mechanism; mechanism for suitably supporting and guiding the rear flap of the envelope-blank as it is conveyed to and upon the creasing-frame; devices combined with the downwardly-swinging folding-bed which are operative after the envelope has been folded thereon and as said bed swings downwardly to positively expel the folded envelope from said bed into the drier and carrier; mechanism for withdrawing envelopes from the drier drum or chain and presenting them in their positions for being moved into the envelope-receiving box, and to an automatic counting mechanism—that is, one which will effect the setting off of the discharged envelopes in series of twenty-five each, so that the ends of the envelopes in one series are placed out of line with the ends of the envelopes of another series; and the invention consists in the construction and combination of parts, all substantially as will hereinafter more fully appear, and be set forth in the claims.

In the accompanying drawings the said improvements are shown as embodied in or forming a part of an envelope-machine substantially such as shown and described in Letters Patent of the United States granted to me July 30, 1889, No. 408,200. Certain of the mechanisms here shown substitute certain of the mechanisms shown as applied on the machine described in said patent, while other of the mechanisms are supplemental to those shown in the machine of said patent.

In the present drawings, Figure 1 is a sectional elevation of the envelope-machine, certain parts being broken away to more clearly illustrate certain other parts. Fig. 2 is a front elevation of the machine. Fig. 3 is a perspective view of certain of the mechanisms at the front and toward one end of the machine, said

mechanisms being those for withdrawing the envelopes from the drier and those for periodically shifting the receiving-box to indicate the bunches. Fig. 4 is a side elevation or face view of certain of the mechanisms comprised in the preceding figure, but as seen looking from the end of the machine shown at the right of said Fig. 3 and inside of the ratchet-wheel therein shown. As the parts in said Fig. 4 are seen as looking in an opposite direction from that necessary to obtain the view Fig. 3, and to avoid confusion as far as possible, the words "front" and "rear" are placed near said view to indicate the positions of the parts relative to the front and rear of the machine. Certain parts comprised in the mechanism illustrated in said elevation are shown in said Fig. 4 as in a projected plan. Fig. 5 is a plan view of certain other of the parts forming part of the counting mechanism. Fig. 6 is a perspective view taken from the rear of the machine, illustrating means for securing the driving of the withdrawal-rollers which are employed for taking the envelopes one by one out from the drier. Fig. 7 is a perspective view of the end-flap gummer and means for operating the same. Fig. 8 is a plan view of the under side of the folding-bed, showing a present improved envelope-expulsion mechanism applied thereon. Figs. 9 and 10 are sections transversely of said folding-bed and through the apertured table of the machine, the said folding-bed in Fig. 9 being shown as swung up into the position occupied thereby at the time an envelope is being folded thereon, while Fig. 10 shows the bed as swinging downwardly. Fig. 11 is a perspective view of parts embodied in said folding-bed mechanism, and shown as detached from each other.

Similar characters of reference indicate corresponding parts in all the views.

*v* represents the front of the machine, and *w* the rear thereof, while *xx* represent the ends of the machine, as herein termed.

The end-flap gummer is illustrated in perspective in Fig. 7, and its position on the machine is indicated in the sectional elevation, Fig. 1, and the front elevation, Fig. 2, the said mechanism being shown as supported on the shelf or gum-box plate *a*, over and to the

right of the blank-elevating table *b*. (See Fig. 2.) The end-flap gummer has a slight movement upwardly off from the gum-supply therefor, then more or less horizontally to carry it over the portion of the blank to be gummied, and is then projected vertically to contact with the proper portion of the blank to be gummied, and in reversal the gummer is then lifted quickly from the blank, then carried more or less horizontally, and is then slightly downwardly moved to place its foot upon the gum-supply.

A represents the end-flap gummer, which is formed as a lateral and downward extension or leg of the racked gummer-carrying bar 20. The rack-bar is pinion-ended—that is, it is provided with gear-teeth in semicircular arrangement, the line of contour of which merges into that of the teeth on the edge of the bar. 22 represents a standard supported rigidly on the gum-box plate, having a vertical slot 23 in its upper portion, and said standard has a pending portion 24, which extends through the aperture 25 in said supporting-plate. In said pending portion 24 of the standard a vertical slot or way 26 is formed, which extends at its upper portion laterally in an arc of a circle. The said gummer-bar 20 has a laterally-projecting stud 27 in its upper end, which projects for a guiding engagement into said upper slot 23, said bar also being provided concentrically within its lower pinion-ended portion with a laterally-extended stud 28, which has a guiding engagement with the lower and partly curved slot 26 in the standard. Said standard forms in part bearings for a horizontal arbor 30, the other bearing therefor being comprised in the standard 32, fixed on said gum-box plate, and the axis of said arbor is concentric with the arc portion of the slot 26. Said arbor at its one end and by the side of the standard 22 carries a spur gear-wheel 33, with which mesh the teeth of the said bar. A pinion 34 is supported on the other extremity of said arbor, and 35 represents a reciprocating rack-bar which meshes with said pinion. This rack-bar is suitably guided vertically, receiving its reciprocatory movement through the connection of the link 36, which by one end thereof is connected to the rack-bar, its other end being connected to the outer end of a radial arm 37 on the rocker-shaft 38, provided as usual for operating the front and rear flap gummiers *f*, which are also the pickers.

The gum-supply for the end-flap gummer is contained by saturation in the sponge or textile pad 39, which is contained in the box 40, supported on the gum-box plate *a*, adjacent the face of the gear-wheel.

The operation of the end-flap gummer is as follows: Assuming that the racked gummer-carrying bar 20 is in the position shown in the drawings, particularly Fig. 7, and the foot of the end-flap-gummer leg is held above the pad in the gum-box, then as the gear 33 is rotated in the direction of the arrow the lower

toothed end of the gummer-bar will be moved to the left and constrained concentrically with said gear until said bar moves tangentially with said gear, as it does when the gummer-bar has been carried to the side of the gear and the teeth along its straight edge are brought into mesh with those of the gear which are horizontally across from its axis. The lower end of the gummer-bar is guided and held in its intermeshing engagement by the pin 28 in the slot 26, while the pin 27 in the upper end of the gummer-bar, working in the straight slot 23, supports the gummer-bar by its upper portion and permitting the proper movements of the gummer-bar prevents the same from having such undue and uncontrollable swinging movements as would render the movements of the bar uncertain and inoperative. As the racked edge of the bar is in engagement with the gear still turning in the direction of the arrow, the foot of the gummer-leg is thrust quickly downward upon the one end of the top blank on the pile to gum same at about the same time that the picker-gummer *f* deposits its gum on the front and rear flaps. On the reverse movement of the gear the end-flap gummer is quickly raised and at the time the toothed end of the gummer-bar is vertically above the axis of the gear the foot of the gummer-leg is above the top of the gum-box; but the said gear before it reverses has a still further rotation in the direction the reverse of that indicated by the arrow, which insures a downwardly-curving movement and thrust of the said foot upon the gumming-pad to receive its coating of gum.

One feature preferably embodied in the end-flap-gumming device consists in the capability of the gummer when in its vertical movements for traveling more rapidly than the large gummer *f*. This is due to the gear 33 being sufficiently larger than the pinion 34, and the advantage arises from the fact that immediately the large picker-gummer *f* begins to rise the end-flap gummer also rises with a much greater speed and is carried out of the way and from any interference with the usual movements of the blank.

In Fig. 1 is illustrated a novel specific device for bridging or projecting over the rear portion of the rectangular opening 50 in the creasing-frame *g*, so that after the plunger has been moved downwardly through said opening 50, to crease the blank and force it upon the folding-bed *h*, and has been raised out of and above said opening, and as the rear-flap folder is swung downwardly upon the bed to fold down the rear flap of the blank as the next blank is brought over upon the creasing-frame by the usual conveyer, the rear portion of the blank will be properly supported, whereby it will be smoothly guided over the rear part of the creasing-frame *g*, and will not be liable to sag and become injured and misplaced by contacting in its rearward movement with the rear vertical wall

of said creasing-opening. 52 represents a curved arm fixed on and more or less radially and forwardly projected from the rocker-shaft 53, and linked to the rear-flap folder 54 for its operation as usual, the said shaft 53 receiving its rocking movements by the connection with its radial arm 55 of the usual thrust-rod 56 for the rear-flap folder, which is generally actuated by a cam on the main shaft. A curved or angular arm B by its rear and lower end is pivoted to said arm 52 intermediately thereof, as at 57, its forward extremity lying on the base of a groove 60, formed in the said creasing-frame at the rear border of said opening. At the upper rear portion, and as a part of Fig. 1, a partial plan projection of the creasing-frame is given to more clearly show said groove 60. After the blank has been brought to its proper position over the creasing-frame and before the plunger descends the flap-folder 54 is swung up, the arm 52, which is connected thereto, swinging rearwardly, and it will be plain that the point 57 of pivotal connection for the arm moving in the curve indicated by the arc line 58 will draw the said arm B rearwardly, so that its free extremity lies outside of the rear wall of the opening *g* and is out of the way of the plunger. The spring 59 is deemed a useful, though not absolutely a necessary, appliance between the arms 52 and B, for while it is usually expected that the forward extremity of the arm B will from its gravity always remain in the bottom of the groove 60 the spring positively insures such disposition of said part. The folding bed or bottom *h* is pivoted at its rear edge, as indicated at 61, to the border of the aperture 62 in the table *y*, and has its periodical swinging motion, so that before the folding flaps are swung down the said bed will be in its uppermost position, the reciprocatory motion of said folding-bed being imparted in the usual manner. The folding-bed is cored out or chambered at its under side, as shown, and parallel slots 63 63 are formed transversely through the top of the bed. Within the said under opening in the folding-bed is an arbor 64, having the arms 65 65 thereon, which project through said slots 63, and said arbor is mounted by its extremities to rock in the bearing-blocks 66 66, which embrace and are adapted to slide on the fixed rods 68, transversely disposed in the under opening of the bed. The sliding bearing-blocks for the said arbor are normally maintained in the rearward positions shown in Figs. 8 and 9 by the spiral springs 67. Each of said arms 65 is formed to extend, when in its position of rest by the portion 69, Fig. 11, upwardly through its slot 63 therefor, and by its angularly and horizontally extended portion 70 in the rear extension of the slot and just below the surface of the bed *h*, the extremity of each arm being upwardly and forwardly turned in the hook, which lies above and to the rear of the surface of the folding-bed top. The arbor is provided with

a radial arm 71, downwardly and forwardly extending when the parts are at rest, and to said arm, by the pin-and-slot connection, as shown, is secured one end of a link 72, which extends across under and is pivotally connected to the bed, as at 75, near its forward edge. A curved link 73 is connected near each end of the arbor 64, and extending downwardly and rearwardly it has by its rear extremity a connection with a suitable part of the envelope-machine table, as at 76. But one of these links 73 is shown in Fig. 11, and that is shown as detached from its position of operative engagement with the end of the arbor 64. When the bed is swung downwardly on the point 61, the distance between the normal position of the axis of the arbor 64 and the point 75 of engagement becomes shortened, and therefore through the forcing action of the links 73 the arbor is forced forward, its end bearing-blocks 66 sliding over the transverse rods 68 against the springs. The distance between the normal position of the extremity of the radial arm and the forward connected point of the link 72 then also shortening, the said radial arm is forced rearwardly by the said interposed link 72, and the arbor is rocked, the radial and hooked envelope-expelling arms swinging forwardly across the upper face of the downwardly-swinging bed. It will be noticed that, as preferably constructed, the arms 65 are adapted only to begin to move transversely with relation to the bed after the bed has been downwardly swung some distance, so that the envelope-expelling action will not be effected while the top surface of the bed is yet out of line with the proper receiving-pocket of the drier-drum, and this peculiarly-timed action is insured by the slot 77 in the rear end of link 72, and the slot 78 in the rear end of each link 73. As to the link 73, the bed swings downwardly without effecting the forward sliding of the arm-carrying arbor until the forward end wall of the slot 78 abuts against the pivotal pin therein engaged, when of course the arbor is forced forwardly, and as to the link 72 the bed swings downwardly a considerable distance before the swinging action of the arms is effected by the pin 79 in the extremity of the radial arm 71 abutting against the forward end wall of the slot in the said link 72. The suitably timed and compound sliding and swinging motion of the envelope-expelling arms, in conjunction with the downward swing of the bed, insures a traverse by the hook ends of said arms more or less, nearly parallel with the top surface of the bed and somewhat as indicated by the dotted line in Fig. 10. The arms, through the connection of the link 72 with the carrying-arbor therefor and the springs 67, are restored to their normal positions as the bed is next again upwardly forced to receive thereon another creased envelope-blank and to sustain thereon the folding of the flaps.

While in the folding-bed as designed for use

I provide two hooked arms working through slots in the bed respectively provided therefor, and I provide two spring-encircled guide-rods, and provide two links for insuring the slide of the arm-carrying arbor, this duplicated arrangement is not necessary, for in view of the illustrations given it would be merely a simple mechanical expedient to equip the bed with a single and centrally-disposed envelope-ejecting arm and operating devices therefor, involving the essential principles above described.

The mechanism for withdrawing the envelopes one by one from the drying chain or drum *j*, which has a step-by-step rotational movement, embodies a pair of rotatable rolls mounted adjacent the side of said drying-chain on a support adapted to be reciprocated laterally to the plane of rotation of said drier-drum, means for insuring the constant rotation of said rollers in the same direction, and means for securing the reciprocation of their carrying-support. The drier-drum here illustrated is substantially the same as that shown and described in the before-mentioned patent granted to me July 30, 1889, the said drum being peripherally provided with envelope-receiving pockets formed by the spaces between the substantially radial arms or spurs 95. The said drier-drum has its intermittent partial rotary motion in the direction of the arrow 96, Fig. 1, and the envelopes discharged from the folding-bed into the drier-drum pockets, which are successively brought under the folding-bed, are, as they are carried around under the machine, prevented from falling out of the pockets by the confining-wires 97, provided in the same arrangement, as set forth in the said patent. Each envelope is withdrawn from the drier when the pocket thereof arrives at one given plane transversely of the drum in its rotation. That given plane for the withdrawal in the illustrations of the machine here supplied is indicated by the oblique line *x*, Figs. 1 and 3. The withdrawal-rolls 98 and 99 are mounted on suitable arbors in oblique planes, so that their contacting peripheries are in the said plane *x*, one of the rolls lying to the rear and the other forward of said plane.

100 represents the carrying-support suitably formed to constitute bearings for the arbors 98' and 99' of said withdrawal-rollers, said support 100 at its lower portion being mounted for movement in the slideway 102 to carry the rolls 98 and 99 parallel with said plane *x*—that is, of course, toward and away from the face of the drier-drum. The reciprocatory motion of the said roller-carrier 100 is imparted through the connection therewith of one end of the pitman-rod 103, which by its other end is connected to the crank-pin 104, revoluble about the axis of the shaft 105, which carries it, said shaft being mounted in suitable bearings therefor and receiving its rotation through the bevel-gear 106 thereon, which meshes with the bevel-gear 107 on the

main shaft *k* of the machine. The said withdrawal-rollers are, in preference, provided on their rims with rubber bands, and the direction of rotation of said rollers is indicated by the arrows thereon in Fig. 3. In practice the amount of throw imparted by the crank-pin 104 to the carrier 100 for the rollers is comparatively slight, about an inch being sufficient. A continuously-driven belt or band 108, (see particularly Fig. 6,) passing around the pulley 109 on the lower end of the arbor 98', insures the continuous rotary motion of the roller 98, the other roller 99 being in frictional contact therewith, receiving its rotation therefrom. Said endless driving-band 108 is driven by a grooved pulley 110 on shaft 105. Of course, as the rollers 98 and 99 have bodily a reciprocatory movement and are driven from the pulley 110 on its fixed shaft the driving-band 108 must have take-up capabilities, whereby it may always be sufficiently taut to rotate the roller 98, and 112 represents a pending arm pivotally mounted, as at 113, on the frame of the machine to have a swinging movement toward and away from the plane of rotation of the drier-drum. The tendency of the spring 114 is to swing the said arm 112 away from the drier-drum. There are on said arm several grooved sheaves or tension-rollers 115, 115', around which portions of the endless band 108 pass. Any slackening which might otherwise occur in the band as the sheave 109 is moved bodily in one direction is taken up by the spring-drawn arm, while any undue tension which would otherwise be upon the band as the sheave is moved in the other direction is provided for by the capability of said arm for swinging against its spring. When the envelopes in the pockets of the drier-drum are brought one by one into the plane indicated by *x*, the carrier 100, having the forwardly-rotating withdrawal-rolls, backs in upon the end edge of the envelope, and the same is impinged upon by the contacting peripheries of said forwardly-rotating rolls, and is immediately fed outwardly toward the end of the machine or in the direction indicated by the arrow 115<sup>a</sup>, Fig. 3. The rapid rotation of said rollers insures the outward feed of the envelopes immediately said rollers are carried sufficiently rearward to secure their peripheral impingement with the envelope and even before the backing-in movement of the carrier has been reversed. Said carrier backs in to permit the rolls to take out the one envelope and then the carrier is moved slightly outwardly, so as not, by itself or its rollers, to present any obstruction to the envelope in the pocket next behind the plane of *x* as it is brought forward into said plane. The bearing on carrier 100 for the arbor of roller 99 is shown as constituted by the sleeve 115<sup>b</sup>, rigidly secured on said carrier, and said sleeve is provided with a lug 116, which is forward of and next to the plane coincident with said plane *x*, in which the envelope moves under the impelling action of

the rollers 98 and 99, and the said lug supports and guides the envelope as its forward edge passes through and forward of the said rollers. Each envelope being fed out by the rapidly-rotating rolls 98 and 99 as its rear end passes forward of the point of peripheral contact between such rollers is given a still further forward impetus from momentum as the parting effect thereon by said rollers, the envelope being by its forward end projected to the inner face of the forward end wall 120 of a frame 122, said envelope traveling just to the rear of a downwardly and rearwardly inclining plate 123, which is cut out at its bottom portion, as at 124, whereby the envelope then under its gravity is permitted to fall through said opening edgewise and to rest by its lower edge upon the rearwardly-extended supporting plate or bar 125 of the pusher 126, which has a regular reciprocating motion from front to rear of the machine at each envelope-forming operation thereof, and which pusher at this time is not in its innermost or rearward position. This pusher 126 is a well-known element in envelope-machines, the object thereof being, after the envelope has been withdrawn from the drier and deposited on top thereof, and then as the part 125 recedes sufficiently far to permit the envelope to drop in front thereof to force such envelopes forwardly into the receiving-box *l*. This pusher 126 receives its reciprocatory motion in any usual way, that employed in the present machine consisting in the connecting-rod 127 being secured to the extension 128 of said pusher and receiving its reciprocating motion from a cam or eccentric (not shown) on the main shaft. The envelope-receiving box *l* is adapted to be reciprocated periodically and laterally to the direction of travel of said pusher 126, as is also common in envelope-machines; but I have devised specific and improved devices by which the periodical shifting of said receiving-box is effected on the passage of each twenty-five envelopes, which will now be described.

*m* represents a ratchet-wheel having thereon fifty teeth, and also having thereon an extended rim 130, provided with diametrically-opposed radial studs 132. Said ratchet-wheel *m* is carried on a shaft 133, horizontally mounted at the end of the machine, and on said shaft 133 is loosely mounted immediately thereof a lever 134, carrying at its one extremity a pallet 135, and said lever also receiving at its other end a connection therewith of the thrust-rod 137, which receives its movements from the cam or eccentric on the main shaft, as a similar ratchet-operating lever is operated in the machine of my before-mentioned patent. Said pallet is adapted, when permitted so to do, to have an engagement with said ratchet-teeth, whereby on each envelope-forming operation of the machine the pallet will force the ratchet-wheel around to the extent of one tooth, and then swing back ready to repeat such operation upon the

next rotation of the main shaft, but then only in the event of the passage of an envelope in advance of the pusher into the receiving-box. There is also loosely mounted on the shaft 133 for the said ratchet-wheel and next to the said swinging lever 134 a radially-extended plate 140, the face of which plate that is toward the ratchet-wheel being shown in Fig. 4. The said plate 140 is provided on the side thereof next to the ratchet-wheel with an arc-shaped and laterally-extended flange 142, which is adapted to extend near to the plane of, but not to overlie the teeth of, the ratchet-wheel. The pallet is provided near its downwardly-turned working extremity with a laterally-extended stud 160, which overlies said flange 142, and when the end of the pallet is in engagement with a tooth of the ratchet-wheel and the pallet is moved the said stud will move along on the top of said arc-shaped flange.

*n* represents a guard-finger by its one end pivoted on the face of the plate 140 and by its free extremity to rest upon the said arc-shaped flange 142. On the free extremity of said guard-finger is the laterally-projected guard projection 165, having its rear portion tapered, as shown at 163 in Fig. 4, the apex of which portion rests upon said flange, and the forward portion of said projection has an edge 166, which inclines rearwardly and downwardly at an acute angle and to contact with said flange. Said plate 140 has projecting from its face which is opposite the one nearest the ratchet-wheel the stud 144, with which the downwardly-extended arm 145 of the rock-shaft 146 engages, and said rock-shaft has a rearwardly-extending fixed radial arm 147, on the extremity of which is a lateral pin 148, which engages in a cam-slot 149 in a segmental plate 150, pivotally mounted for a partial rotation in a vertical plane adjacent to and coincident with the direction of forward travel of the said pusher 126. Said segmental plate has the upwardly-extended projection 152, and also the horizontally and rearwardly extended projection 153. The said upward projection 152 extends substantially radially from the pivotal point 154 of said segmental plate for a less distance than does the projection 153, and the said pusher 126 is provided with an aperture 155, extending from its lower edge, and having such a height that the said pusher in its forward movement and with no envelope in advance thereof will freely pass by and without effect upon the said projection 152; but when an envelope overlies said aperture 155 such envelope forms, as it were, a solid bridge for said aperture, and as the pusher is forwardly moved the segmental plate 150 will be rotated about a quarter of a turn, and the arm 147 will be upwardly swung, and the arm 145 will be carried rearwardly, permitting the plate 140 to be rearwardly swung to carry the guard projection 165 rearwardly out of contact with the stud 160 on the end of the pallet

which at that time is resting on the said projection 165, so that the pallet may drop into a ratchet-tooth, and as the lever 134 then swings to carry the pallet forward around the ratchet-wheel the said wheel will be rotated to the extent of one tooth; but when no envelope is carried out in advance of the pusher and said segmental plate is not swung and the plate 140 is not permitted to swing rearwardly then as the pallet is rearwardly moved to take into the next tooth of the ratchet-wheel the pivoted finger, and essentially its lateral projection 165, is retained in such position that the stud 160 of the pallet, which has in its next forward movement ridden up on the inclined and laterally-extended part 165 of said guard, is by said then unmoved part held out of engagement with the ratchet-tooth. Of course, as is plain, the provision of these devices described insures the non-rotation of the ratchet-wheel whenever an envelope fails to be carried forwardly in advance of the pusher into the envelope-receiving box. It is to be understood that after the parts have assumed the relations occupied thereby at the time the ratchet is being forced forward by the pallet the stud 160 of the pallet is permitted to pass to the rear of the guard projection as the pallet is given its forcing movement by the impingement of the stud 160 upon the inclined edge 166, and as the plate 140 resumes its forwardly-swung position the plate 150 is caused to resume its position for holding the pallet-guard in the relation to the pallet, which is shown in Fig. 4, by the shaft 146 being rocked back as the pusher 126, receding, strikes by the portion thereof just above the aperture 155 upon the then upturned arm 153 of the said segmental and cam-slotted plate and secures in part by positive contact and pressure and in part by the impetus given by said pusher to said arm 153 the return of the said segmental and arm-provided plate to the said indicated position. 190 represents a stop-pin on the frame suitably located to prevent the plate 140 from being swung (from any impetus that may be imparted thereto by the devices described as it is returned to its normal position shown) beyond said desired or normal position.

*p* represents a vertical shaft rotatable in suitable bearings of the frame of the machine, and having on its lower end, which is approached near to the extended rim 130 of the ratchet-wheel, a fixed cam *q*, having two inclined and working edges 175 175, the said cam being adapted to receive as the ratchet-wheel rotates the impingement on one or the other of its edges of the one or the other of the radial studs 132, projected from said ratchet-rim 130, it being noted that said studs, in addition to being diametrically opposite each other, are arranged in planes transversely of the axis of the ratchet-wheel, which planes of arrangement are separated from

each other, and when one of the studs 132 impinges on the one cam edge to swing the cam so that such pin may pass by, the other working edge of the cam is placed in a position to receive a similar impingement of the other stud 132, when twenty-five more envelopes have been discharged from the machine and the ratchet-wheel has made half a rotation. On the upper end of the said shaft is a sector-gear 177, which has an engagement with a rack-bar 178, which by its extension 179 is connected to the laterally-movable platform 180, on which is mounted the receiving-box. Said platform of course, if desired, may be made to form the bottom of the receiving-box. As each twenty-five envelopes pass out of the machine and the cam-footed shaft *p* is partially turned, the said platform will, through the connection with said shaft, be moved laterally of the machine in one direction, it again being by said instrumentalities moved in the other direction on the discharge of the next twenty-five envelopes, and thereby, as well known, the ends of every series of envelopes to constitute one bunch will be automatically set-off from the ends of the series constituting the next bunch.

In lieu of the sector-gear and rack connection between the shaft *p* and the receiving-box bottom, a simple radial arm may be substituted for the sector, and to said radial arm one end of a connecting-rod may be secured, which by its other end is connected to the bottom of the receiving-box.

What I claim as my invention is—

1. An end-flap gummer for envelope-machines and means for operating the same, consisting of parts in combination, viz: a rock-shaft having a gear mounted thereon, a standard adjacent said gear, having a slot which is in part concentric with said gear and in part tangential thereto, and another slot, as the one 23, and a pinion-ended bar 20, having the slot-engaging studs 28 and 27, and provided with gear-teeth continuing from its pinion-formed end along its one edge, and having a gumming-leg, substantially as described.
2. In an envelope-machine, the combination, with a suitable support having thereon a gum-receptacle, and a standard having therein slots 26 23, of a rock-shaft having thereon a gear, a pinion-ended bar 20, having the slot-engaging studs 28 27, and provided with gear-teeth continuing from its pinion-formed end along its one edge, and having a gumming-leg, and means for imparting a rocking motion to said rock-shaft, substantially as described.
3. In an envelope-machine, as an improvement in the creasing and folding mechanism thereof, the combination, with the apertured creasing-frame and with the rear-flap folder therebelow, and an oscillatory arm connected to said folder for operating same, of the arm B by its one portion pivoted to an intermediate part of said folder-operating arm and by

its free extremity lying and movable upon the rear of said creasing-frame, substantially as and for the purpose set forth.

4. The combination, with the downwardly-  
5 swinging folding-bed transversely slotted, provided on its underside with an arbor adapted to move laterally of said folding-bed and adapted to have a rocking movement, and provided with an envelope-expelling arm projected through said slot, of means for insuring on the swinging of the folding-bed a sliding of said arbor and also the rocking thereof, for the purpose set forth.

5. The combination, with the downwardly-  
15 swinging folding-bed transversely slotted, provided on its under side with an arbor adapted to move laterally of said bed, and provided with an envelope-expelling arm extended therefrom through said slot, and also provided with the radial arm 71, of a link-bar, as 73, by its one end connected to said sliding arbor and by its other end connected to a fixed part of the machine, and a link, as the one 72, connected to said radial arm 71 and to a fixed part of the machine, all whereby as said folding-bed is swung the said link-bar 73 will insure a sliding of the arbor and the link 72 will insure a rocking thereof, substantially as described.

6. The combination, with the downwardly-  
30 swinging and transversely-slotted folding-bed provided on its under side with a pair of laterally-extended guide-rods 68 68, of bearings 66, movable along said rods, the arbor 64, by its ends mounted to rock in said sliding bearings and provided with an envelope-expelling arm, as 65, extended therefrom through said slot, and means for insuring on the downward swinging of the folding-bed the forward  
40 sliding of said arbor and a rocking movement thereof, substantially as described.

7. The combination, with the downwardly-  
45 swinging folding-bed transversely slotted and provided on its under side with an arbor adapted to move laterally of said bed, having an envelope-expelling arm extended therefrom through said slot, and provided with the radial arm 71, of a link-bar 73, by its one end connected to said sliding arbor and by its  
50 other end having a pin-and-slot engagement, substantially as described, with a fixed part of the machine, and a link 72, having a pin-and-slot engagement with said radial arm 71 and by its other end to a fixed part of the machine, substantially as described, and a retracting-spring for said arbor, and all as and for the purpose set forth.

8. In an envelope-machine, the combination, with a fixed shaft having thereon a pulley, and with a reciprocatory carrier having thereon a pair of peripherally-contacting rollers, one thereof being provided on its arbor with a pulley, of a driving-band passing around said pulleys, and a movable and

spring-constrained tension-regulating arm or bar having by one or more sheaves thereon an engagement with said driving-band, substantially as and for the purpose set forth.

9. In an envelope-machine, the combination, with a support for an envelope-receiving box adapted to have a reciprocatory movement, a ratchet-wheel having an extended rim provided with radial pins at different points around the periphery of said rim and located in different planes transversely of the axis of said ratchet-wheel, of the shaft *p*, having on its end a double-edged cam for impingement on its opposite edges successively by said pins in the rotation of said ratchet-wheel, and connections between said shaft  
70 and said receiving-box support; whereby as the shaft is partially turned in either direction the said receiving-box support will be correspondingly moved, substantially as described.

10. In a counting mechanism for an envelope-machine, the combination, with the ratchet-wheel and the reciprocatory arm 134, carrying the pallet to engage the teeth of the ratchet-wheel, which pallet is provided with a laterally-extended stud 160, the plate 140, loosely mounted on the shaft of the ratchet-wheel and provided with the pivoted guard-arm having the lateral extension 165 and the arc-shaped flange 142, a rock-shaft having a radial arm engaging and controlling the movements of said plate 140, and mechanism interposed between the envelope-discharging place in the machine, and said rock-shaft for rocking the latter on the passage of an envelope out of the machine, all substantially as described.

11. In an envelope-machine, the combination, with suitable fixed guideways of the machine, as 102, and the rotatable shaft 105, having a crank thereon, of the carrier 100, movable in said guideways and having the rollers 98 and 99 rotatably mounted thereon, and the pitman-rod 103, connecting said crank and said carrier, substantially as described.

12. The combination, with the envelope drier and carrier and a pair of rotatable envelope-withdrawal rollers mounted to reciprocate toward and from said drier, of the frame 123, having the inclined top apertured, as at 124, in advance of the outward limit of movement of said withdrawal-rollers, the pusher 126, adapted to reciprocate across the direction of withdrawal of envelopes by said rollers, and provided at its upper edge with the rearwardly-extended supporting-extension 125, all substantially as and for the purpose set forth.

ALVIN D. TYRREL.

Witnesses:

WM. S. BELLOWS,  
G. M. CHAMBERLAIN.