



(11) **EP 4 104 697 A1**

(12) **EUROPEAN PATENT APPLICATION**

(43) Date of publication:
21.12.2022 Bulletin 2022/51

(51) International Patent Classification (IPC):
A41D 13/015^(2006.01)

(21) Application number: **22189606.1**

(52) Cooperative Patent Classification (CPC):
A41B 1/00; A41D 1/06; A41D 27/28; A41D 29/00

(22) Date of filing: **05.08.2019**

(84) Designated Contracting States:
AL AT BE BG CH CY CZ DE DK EE ES FI FR GB GR HR HU IE IS IT LI LT LU LV MC MK MT NL NO PL PT RO RS SE SI SK SM TR

(72) Inventor: **GILL, Yoram**
3434407 71A Horev Street, Haifa (IL)

(30) Priority: **29.08.2018 IL 26147418**

(74) Representative: **Pearl Cohen Zedek Latzer Baratz UK LLP**
The Gridiron Building
One Pancras Square
London N1C 4AG (GB)

(62) Document number(s) of the earlier application(s) in accordance with Art. 76 EPC:
19854752.3 / 3 843 571

(71) Applicant: **Source Vagabond Systems Ltd.**
39100 Tirat Ha'Carmel (IL)

Remarks:

This application was filed on 09-08-2022 as a divisional application to the application mentioned under INID code 62.

(54) **PROTECTIVE COMBAT CLOTHING**

(57) Protective pad (400) for a knee or an elbow comprising an impact distribution layer (404), a puncture resistant layer (403) and a cushioning layer (402), the protective pad is configured to dynamically change from a generally flat orientation, along the elongated axis of the leg or arm, when placed over a straightened knee or elbow, to a bent orientation, when the knee or elbow bend, in compliance with the bending of that limb.

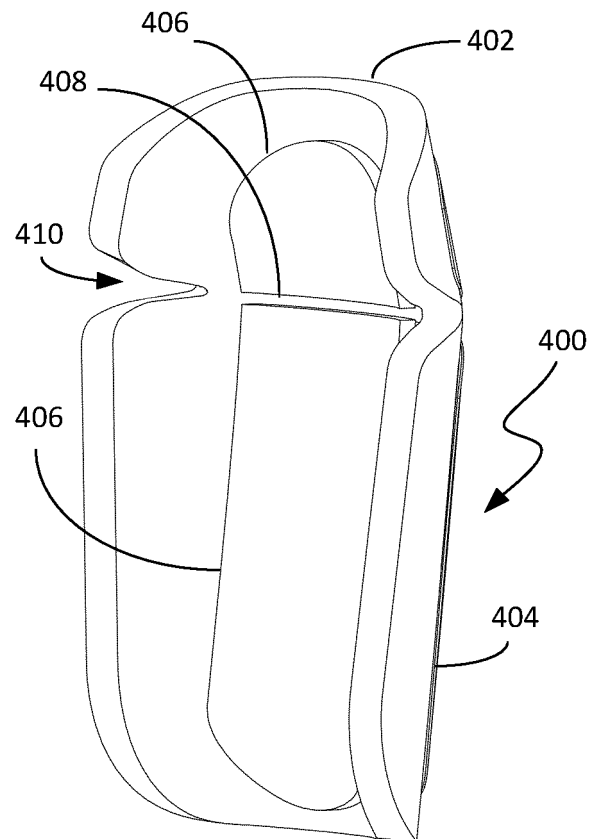

Fig. 4A

EP 4 104 697 A1

Description

FIELD OF THE INVENTION

[0001] The present invention relates to protective combat clothing.

BACKGROUND OF THE INVENTION

[0002] Military uniform is standardized clothing designed to be worn by soldiers and paramilitary forces.

[0003] Official dress uniform is designed to be worn at ceremonies and on formal occasions.

[0004] Battledress is typically, field dress uniform designed for field and routine work, typically outdoor, but is also used for office work, in camps and barracks.

[0005] In many armies, battledress is worn by soldiers in combat, however, it may be desired to introduce protective combat clothing with enhanced protection and other safety and comfort features.

SUMMARY OF THE INVENTION

[0006] There is thus provided, in accordance with an embodiment of the present invention, Protective combat clothing (PCC) comprising a shirt and trousers, wherein the shirt and the trousers are at least partially made of woven fabric made of a composition of the materials comprising flame-resistant fiber, flame-resistant meta-aramid fiber, heat-resistant fiber, polyamide and anti-static fiber.

[0007] According to some embodiments of the invention, the composition of the materials comprises Lenzing FR[®], Nomex[®], Kevlar[®], polyamide and anti-static fiber.

[0008] According to some embodiments of the invention, the composition of the materials comprises 30-60% Lenzing FR[®], 20-50% flame-resistant meta-aramid fiber, e.g., Nomex[®], 10-25% Kevlar[®], 5-20% polyamide and 1-5% anti-static fiber.

[0009] According to some embodiments of the invention the shirt and the trousers comprise each at least a pair of venting openings.

[0010] According to some embodiments of the invention, the shirt comprise two pairs of spaced apart venting openings.

[0011] According to some embodiments of the invention, each pair of venting openings of the at least two pairs of venting opening of the shirt comprises a venting opening on a forearm section of a sleeve, and a venting opening at an armpit section of the shirt adjacent to that sleeve.

[0012] According to some embodiments of the invention, the trousers comprise a pair of venting openings, each of the openings located across thighs of the trousers, one at each of the thighs.

[0013] According to some embodiments of the invention, the venting openings are designed to be closed or opened.

[0014] According to some embodiments of the invention, the venting openings include, each a zipper for closing or opening that venting opening.

[0015] According to some embodiments of the invention, a net is placed over each of the venting openings.

[0016] According to some embodiments of the invention, each of the sleeves of the shirt and each of the pant legs of the trousers includes a pocket for a pad.

[0017] According to some embodiments of the invention, the pocket includes a closable opening.

[0018] According to some embodiments of the invention, the pocket includes a strap of hook-and-loop fastener.

[0019] According to some embodiments of the invention, the PCC includes a pair of elbow pads and a pair of knee pads.

[0020] According to some embodiments of the invention, each of the elbow pads and each of the knee pads comprises a three-layered article.

[0021] According to some embodiments of the invention, the three-layered article includes an impact distribution layer, a puncture-resistant layer and a cushioning layer.

[0022] According to some embodiments of the invention, each of the pads presents a curvature that is substantially orthogonal to and extending along an elongated axis of the pad, and is configured to bend along a bending axis that is substantially orthogonal to the elongated axis.

[0023] According to some embodiments of the invention, a layer of the three-layered article comprises two partially overlapping parts.

[0024] According to some embodiments of the invention, the two partially overlapping parts are connected such that an edge of one of the parts over the other part is not secured to that other part, allowing bending of the first layer about the bending layer.

[0025] According to some embodiments of the invention, the PCC may further include underwear.

[0026] According to some embodiments of the invention, the underwear is made as a complete piece of clothing from UHMWPE knit fabric.

BRIEF DESCRIPTION OF THE DRAWINGS

[0027] In order for the present invention, to be better understood and for its practical applications to be appreciated, the following Figures are provided and referenced hereafter. It should be noted that the Figures are given as examples only and in no way limit the scope of the invention. Like components are denoted by like reference numerals.

Fig. 1 is a front view of an infantry soldier wearing protective combat clothing, according to some embodiments of the present invention.

Fig. 2 is a rear view of an infantry soldier wearing protective combat clothing (PCC), according to

some embodiments of the present invention.

Fig. 3 is a front view of an infantry soldier wearing protective combat clothing, according to some embodiments of the present invention, with open venting openings.

Fig. 4A is a rear view of a knee (or elbow) pad, according to some embodiments of the present invention.

Fig. 4B is a front view of a knee (or elbow) pad, according to some embodiments of the present invention.

Fig. 4C is an exploded view of a knee (or elbow) pad, according to some embodiments of the present invention.

Fig. 4D illustrates bending compliance of a knee or elbow pad, according to some embodiments of the present invention.

Fig. 5A is a front view of a PCC underwear, according to some embodiments of the invention.

Fig. 5B is a back view of a PCC underwear, according to some embodiments of the invention.

DETAILED DESCRIPTION OF THE INVENTION

[0028] In the following detailed description, numerous specific details are set forth in order to provide a thorough understanding of the invention. However, it will be understood by those of ordinary skill in the art that the invention may be practiced without these specific details. In other instances, well-known methods, procedures, components, modules, units and/or circuits have not been described in detail so as not to obscure the invention.

[0029] Although embodiments of the invention are not limited in this regard, the terms "plurality" and "a plurality" as used herein may include, for example, "multiple" or "two or more". The terms "plurality" or "a plurality" may be used throughout the specification to describe two or more components, devices, elements, units, parameters, or the like. Unless explicitly stated, the method embodiments described herein are not constrained to a particular order or sequence. Additionally, some of the described method embodiments or elements thereof can occur or be performed simultaneously, at the same point in time, or concurrently. Unless otherwise indicated, the conjunction "or" as used herein is to be understood as inclusive (any or all of the stated options).

[0030] PCC, according to some embodiments of the present invention, may be also referred to as combat uniform, field uniform, battledress, fatigues, etc. is aimed at providing a combat soldier (e.g., an infantry soldier)

with enhanced protection from various hazards, which the soldier may face in combat situations, and offer added comfort.

[0031] PCC according to some embodiments of the present invention is aimed at providing a complete set of protective combat clothing for an infantry soldier, so as to meet various requirements. For example, such requirements may include making all or some parts of the clothing from fire-retardant material or materials, possessing some ballistic protection, having paddings at particular places (e.g., knees, elbows).

[0032] PCC according to some embodiments of the present invention may be made of a various textile materials. For example, PCC may include and/or incorporate knit, weave, non-woven fabric, etc.

[0033] Fig. 1 is a front view of an infantry soldier wearing PCC 100, helmet 102 and boots 152, according to some embodiments of the present invention.

[0034] Fig. 2 is a rear view of an infantry soldier wearing protective combat clothing, according to some embodiments of the present invention.

[0035] PCC 100 may include trousers 106, shirt 104 and underwear (the latter not shown in this figure, see Figs. 5A and 5B).

[0036] The shirt 104 and/or trousers 106 may be made or at least include textiles which are designed to withstand stubbing and/or slashing, or stop high and/or low velocity projectiles and/or shrapnel and or ricochets. In some embodiments of the present invention, at least part or parts of the shirt are made of textile comprising polyethylene felt. In some embodiments of the present invention small polymeric discs (e.g., discs with a diameter ranging between 1-4 mm) are printed over the fabric of the trousers and/or shirt for increased durability. In some embodiments of the invention, zones of the textile of the trousers and/or shirt, at the knees and elbows are reinforced for enhanced durability and added protection from wear.

[0037] The shirt may include one or a plurality of enhanced protection zones, such as, for example, collar, shoulders and lower abdomen and back portions, all marked by 103, which may be made of ultrahigh molecular weight polyethylene (UHMWPE), or other ballistic protective material, so as to prevent penetration of low velocity projectiles and/or shrapnel and or ricochets. Shirt 104 may include a zipper 105 for opening or closing the neck zone, to allow the soldier to put the shirt on or remove it. Shirt 104 may comprise a torso portion 108 and sleeves 110. Shirt 104 may comprise sections made of different textile types. Types of textiles used in making of shirt 104 and/or trousers 106 may include, knit, weave, not-woven fabric, etc. and possess various textile characteristics. For example, the torso portion (front and/or back) 108 may be made of breathable, quick-dry material, so as to allow cooling of the body of the soldier, when heated as a result of physical strain in action.

[0038] Pocket 112 may be provided on each of the sleeves 110 designed to allow the soldier to carry small

items, such as documents, a pocket knife, a small flashlight, etc. Pockets 112 may be, each, provided with an opening 114. Opening 114 may be controlled - opened or closed - by a zipper 116. The zipper may be opened to allow insertion of items into the pocket, or for removing them from the pocket. Zipper 116 may be provided for closing and opening opening 114.

[0039] Shirt 104 may be provided with at least two pairs of venting openings 120 and 122. Venting openings may be provided with a zipper 124, so as to allow the soldier to open or close the venting opening. The venting openings may be located at spaced apart locations so as to allow, when open, air to pass inside the shirt, and cool the soldier's body. In some embodiments of the present invention, one venting opening 112 may be located on the part of the sleeve 110 adjacent to the position of the forearm of the soldier, when wearing the shirt. In some embodiments of the present invention the other venting opening may be located adjacent to the armpit, at the meeting of the sleeve with the torso portion of the shirt.

[0040] Shirt 104, according to some embodiments, includes elbow pads. In order to facilitate appropriate fit of the elbow pad to the elbow of the soldier, each sleeve 110 may include a pad pocket 202, which is designed to hold an elbow pad (for example, see Figs. 4a-4c). Each elbow pad pocket 202 may comprise an enclosure with an opening 204, through which an elbow pad is inserted and placed in position. After insertion of the elbow pad, the opening 204 may be closed. The opening may be sealed using a fastener, e.g., hook-and-loop fastener 208. The soldier wearing the shirt may reposition the elbow pad within the elbow pad pocket, so as to properly align the elbow pad with the elbow, when wearing the shirt. In order to facilitate repositioning of the elbow pad, an elongated hook (or loop) strap of hook-and-loop fastener 206 extends inwardly along the inner surface of the pocket. A matching patch of loops (or hooks) of a hook-and-loop fastener is provided on the lower end of the elbow pad (see 412, Fig. 4B). The dimensions of the elbow pad pocket 202 are big enough, so as to allow positioning higher or lower within the pocket, and attaching the hook-and-loop parts 206 and 412 (see Fig. 4B) in the desired position, in order to properly align the elbow pad with the elbow of the soldier wearing the shirt 104.

[0041] Fastening strap 118, e.g., with hook-and-loop fastener may be provided to firmly secure the elbow pads to the elbows of the soldier wearing the PCC.

[0042] In some embodiments of the present invention, the front and/or back torso portions of the shirt 104 may be made of a knitted fabric.

[0043] In some embodiments of the present invention the knitted fabric of the torso portions of the shirt 104 may include, for example, the following composition of materials: flame-resistant fiber, e.g., Lenzing FR[®], flame-resistant meta-aramid fiber, e.g., Nomex[®], elastic fiber, e.g., Lycra[®], heat-resistant, strong fiber, e.g., Kevlar[®], and carbon fibers.

[0044] In some embodiments of the present invention,

the knitted fabric of the torso portions of shirt 104 may include the following composition of materials: 45-65% Lenzing FR[®], 15-30% Nomex[®], 5-20% Lycra[®], 2-10% Kevlar[®], and 1-5% Pes/PA/ carbon.

[0045] Typically in combat situations a soldier may also be wearing a tactical vest over the shirt that protects large parts of the front and back torso.

[0046] In some embodiments of the invention, the sleeves 110 of shirt 104 and the trousers 106 may be made of a woven fabric.

[0047] In some embodiments of the present invention, the woven fabric of the shirt and/or trousers, may include, for example, the following composition of materials: flame-resistant fiber, e.g., Lenzing FR[®], flame-resistant meta-aramid fiber, e.g., Nomex[®], heat-resistant, strong fiber, e.g., Kevlar[®], polyamide and anti-static fiber.

[0048] In some embodiments of the present invention, the woven fabric of the shirt and/or trousers, may include, for example, the following composition of materials: 30-60% Lenzing FR[®], 20-50% flame-resistant meta-aramid fiber, e.g., Nomex[®], 10-25% Kevlar[®], 5-20% polyamide and 1-5% anti-static fiber.

[0049] A PCC according to some embodiments of the invention, may also include a pair of gloves 124. Each glove may include a fastening strap 126 for firmly holding the glove about the wrist of the soldier wearing the gloves 124.

[0050] Trousers 106 may comprise of a pelvis portion 109 and two pant legs 132. Trousers 106 may include a belt 107. Trousers 106 may include pockets, e.g., pockets 134, 150, at various positions. For example, hip pocket 134 may include a top opening covered by top cover 138. Hip pocket 134 may also include a side opening 136, which may be opened or closed using a zipper 137 that is provided across the side opening 136.

[0051] The trousers 106 may be made of textile/s that are stab or slash resistant.

[0052] Trousers 106 may include venting openings 128. The soldier may keep the venting openings 128 closed or opened, by employing a zipper (shown is the zipper puller 130). By opening the venting openings, the soldier may facilitate air flow through the trousers so as to cool the soldier's body. In some embodiments the venting openings 128 may be positioned across the thighs, one at each of the thighs, as illustrated in Fig. 1. Other design arrangements of the venting openings may also be employed.

[0053] On each leg pant 132 a knee pad pocket 140 may be provided. Similarly to the elbow pad pockets, the knee pad pockets 140 may be located at the anticipated position of the knee of the soldier who is to wear the trousers 106. Each knee pad pocket 140 is designed to receive a knee pad.

[0054] Each knee pocket 140 has an opening (e.g. a bottom opening 144, through which the knee pad may be inserted into the pocket. A fastener, e.g. hook-and-loop fastener 148 is placed across opening 144, so that the knee pad may be inserted and the pocket opening

144 is then sealed by the fastener 148.

[0055] In order to facilitate appropriate positioning of the knee pad against the knee of the soldier wearing the trousers, the knee pad pocket is designed so as to allow repositioning of the knee pad within the pocket.

[0056] An elongated strap 146 of a hook-and-loop fastener extends inwardly on the inside surface of pocket 140, so that the knee pad may be properly positioned adjacent to the knee of the soldier, and secured in position, by attaching the matching patch 412 of the hook-and-loop fastener (see Fig. 4B) to corresponding strap 146. This ensures that the soldier may rearrange the knee pad inside knee pad pocket 140 to lay at a proper and convenient position. Strap 142 (e.g., comprising two co-operating fastener straps 142a and 142b) may be used to fasten the pant leg and secure the knee pad in its proper position against the soldier's knee.

[0057] Fig. 3 is a front view of an infantry soldier wearing protective combat clothing, according to some embodiments of the present invention, with open venting openings.

[0058] Venting opening 128 (this may apply to any venting opening provided on the PCC) may include a zipper across the opening (shown is the zipper puller 130) for opening or closing the venting opening. Net (e.g., mesh) 302, with holes of predetermined size, may be placed over the opening to allow ventilation and prevent entry of dirt, bugs, etc. through the net 302.

[0059] Fig. 4A is a rear view of a knee (or elbow) pad 400, according to some embodiments of the present invention.

[0060] Fig. 4B is a front view of a knee (or elbow) pad 400, according to some embodiments of the present invention.

[0061] Fig. 4C is an exploded view of a knee (or elbow) pad 400, according to some embodiments of the present invention.

[0062] Pad 400 may be designed as a three-layered article.

[0063] Top protection layer 404 may be impact-distribution layer 404, which is aimed at distributing an impact on the knee, when kneeling or otherwise. This layer may be made, for example, from a laminate of polypropylene and aramide, and is aimed at distributing an incoming impact over the layer so as to reduce the pressure imparted by the impact on the knee and minimize any risk of damage.

[0064] Second protection layer 403 (see Fig. 4C) may be a puncture-resistant layer, which may be made, for example from aramide. This layer is designed to prevent, or greatly reduce the possibility of a sharp object, such as, for example, a blade, a nail, broken glass, etc. from penetrating the pad and injuring the soldier's knee, when kneeling down.

[0065] A third cushioning layer 402 - which is designed to face the knee or elbow, serves as a cushioning layer, to cushion the knee, when placed on the ground, when the soldier kneels, or when coming in contact with or hit

by a rigid object (e.g., wall, stone, metal object, etc.). The third layer may be made, for example, from ethylene-vinyl acetate (EVA), polyethylene foam, etc.

[0066] Fig. 4D illustrates bending compliance of a knee or elbow pad, according to some embodiments of the present invention.

[0067] The elbow or knee pad, according to some embodiments of the present invention are designed to dynamically change from a generally flat orientation, along the elongated axis of the leg or arm, when placed over a straightened knee or elbow, to a bent orientation, when the knee or elbow bend, in compliance with the bending of that limb. At the same time, the pad is designed to present a curvature that is orthogonal to and extending along the longitudinal axis of the limb, so as to conform to the curvature of the limb.

[0068] Thus, according to some embodiments, the pad has a substantially fixed curvature 414 orthogonally to the elongated axis 415. The cushioning layer may be provided with two substantially opposite indentations 410, which define an axis extending between these indentations, about which the pad may bend. A groove 408 in the cushion padding 406 may enhance this bending axis, as the padding is likely to more readily yield along the groove 408 in response to bending force applied on the pad.

[0069] The second puncture resistant layer is typically rather thin and possess some flexibility, that allows it to bend easily with the bending of the third cushioning layer.

[0070] The first, impact distribution layer, is typically hard and not as flexible as the other two layers. Furthermore, because of its curvature extending along the elongated axis, it may be hard to bend it about the bending axis 413, which is substantially orthogonal (right angle 418) to the elongated axis 415. To address this problem the first puncture-resistant layer 404 may be comprised of two parts 404a and 404b, which partially overlap. The two parts may be stitched together along stitch line 407, so that the edge 409 of part 404b, which is over part 404a, is free - not secured to part 404a. Thus, when the pad is bent in conjunction with bending of the knee or elbow, a bend curvature 416 of the pad may be obtained.

[0071] Fig. 5A is a front view of a PCC underwear 500, according to some embodiments of the invention.

[0072] Fig. 5B is a back view of a PCC underwear 500, according to some embodiments of the invention.

[0073] Underwear 500 may be made as a complete piece of clothing 502, from for example, UHMWPE knit fabric, for enhanced protection against shrapnel and/or ricochets. A rubber band 504 may be provided for holding the underwear about the waist and/or thighs of the wearer. Preferably, Lycra threads may be incorporated into the UHMWPE knit fabric for added flexibility and comfort.

[0074] Different embodiments are disclosed herein. Features of certain embodiments may be combined with features of other embodiments; thus certain embodiments may be combinations of features of multiple embodiments. The foregoing description of the embodi-

ments of the invention has been presented for the purposes of illustration and description. It is not intended to be exhaustive or to limit the invention to the precise form disclosed. It should be appreciated by persons skilled in the art that many modifications, variations, substitutions, changes, and equivalents are possible in light of the above teaching. It is, therefore, to be understood that the appended claims are intended to cover all such modifications and changes as fall within the true spirit of the invention.

[0075] While certain features of the invention have been illustrated and described herein, many modifications, substitutions, changes, and equivalents will now occur to those of ordinary skill in the art. It is, therefore, to be understood that the appended claims are intended to cover all such modifications and changes as fall within the true spirit of the invention.

[0076] The disclosure of the present invention also includes the subject matter of the following clauses:

1. Protective combat clothing (PCC) comprising a shirt and trousers, wherein the shirt and the trousers are at least partially made of woven fabric made of a composition of the materials comprising flame-resistant fiber, flame-resistant meta-aramid fiber, heat-resistant fiber, polyamide and anti-static fiber.

2. The PCC of clause 1, wherein the composition of the materials comprises Lenzing FR[®], Nomex[®], Kevlar[®], polyamide and anti-static fiber.

3. The PCC of clause 2, wherein the composition of the materials comprises 30-60% Lenzing FR[®], 20-50% flame-resistant meta-aramid fiber, e.g., Nomex[®], 10-25% Kevlar[®], 5-20% polyamide and 1-5% anti-static fiber.

4. The PCC of any of clauses 1 to 3, wherein the shirt and the trousers comprise each at least a pair of venting openings.

5. The PCC of clause 4, wherein the shirt comprise two pairs of spaced apart venting openings.

6. The PCC of clause 5, wherein each pair of venting openings of the at least two pairs of venting opening of the shirt comprises a venting opening on a forearm section of a sleeve, and a venting opening at an armpit section of the shirt adjacent to that sleeve.

7. The PCC of clause 4, wherein the trousers comprise a pair of venting openings, each of the openings located across thighs of the trousers, one at each of the thighs.

8. The PCC of clause 4, wherein the venting openings are designed to be closed or opened.

9. The PCC of clause 8, wherein the venting openings include, each a zipper for closing or opening that venting opening.

10. The PCC of clause 8, wherein a net is placed over each of the venting openings.

11. The PCC of any of clauses 1 to 10, wherein each of the sleeves of the shirt and each of the pant legs of the trousers includes a pocket for a pad.

12. The PCC of clause 11, wherein the pocket includes a closable opening.

13. The PCC of clause 11, wherein the pocket includes a strap of hook-and-loop fastener.

14. The PCC of clause 11, wherein the PCC includes a pair of elbow pads and a pair of knee pads.

15. The PCC of clause 14, wherein each of the elbow pads and each of the knee pads comprises a three-layered article.

16. The PCC of clause 15 wherein the three-layered article includes an impact resistant later, an puncture-resistant layer and a cushioning layer.

17. The PCC of clause 16, wherein each of the pads presents a curvature that is substantially orthogonal to and extending along an elongated axis of the pad, and is configured to bend along a bending axis that is substantially orthogonal to the elongated axis.

18. The PCC of clause 17, wherein a layer of said three-layered article comprises two partially overlapping parts.

19. The PCC of clause 18, wherein the two partially overlapping parts are connected such that an edge of one of the parts over the other part is not secured to that other part, allowing bending of the first layer about the bending layer.

20. The PCC of any of clauses 1 to 19, further comprising underwear.

21. The PCC of clause 20, wherein the underwear is made as a complete piece of clothing from UH-MWPE knit fabric.

Claims

1. A protective pad for a knee or an elbow comprising:
- an impact distribution layer;
 - a puncture resistant layer; and

- a cushioning layer,
 wherein the protective pad is configured to dynamically change from a generally flat orientation, along the elongated axis of the leg or arm, when placed over a straightened knee or elbow, to a bent orientation, when the knee or elbow bend, in compliance with the bending of that limb. 5
2. The protective pad of claim 1, wherein the impact distribution layer comprises two partially overlapping parts. 10
3. The protective pad of claim 2, wherein the two partially overlapping parts are linked such that an edge of one of the overlapping parts that is located over the other part of the partially overlapping parts is not secured to that other part, allowing bending of the protective pad. 15
20
4. The protective pad of claim 1, wherein the cushioning layer comprises two opposite indentations which define an axis extending between the two indentations about which the pad may bend. 25
5. The protective pad of claim 4, wherein the cushioning layer comprises a groove along the axis extending between the two indentations for enhancing the axis.
6. The protective pad of claim 1, wherein the impact distribution layer comprises two opposite indentations which define an axis extending between the two indentations about which the pad may bend. 30
7. The protective pad of claim 1, wherein the puncture resistant layer comprises two opposite indentations which define an axis extending between the two indentations about which the pad may bend. 35
8. The protective pad of claim 1, wherein the cushioning layer comprises ethylene-vinyl acetate (EVA) or polyethylene foam. 40
9. The protective pad of claim 1, wherein the impact distribution layer comprises a laminate of polypropylene and aramide. 45
10. The protective pad of claim 1, wherein the puncture resistant layer comprises aramide. 50
11. The protective pad of claim 1, wherein the impact distribution layer is less flexible than the puncture resistant layer and the cushioning layer. 55

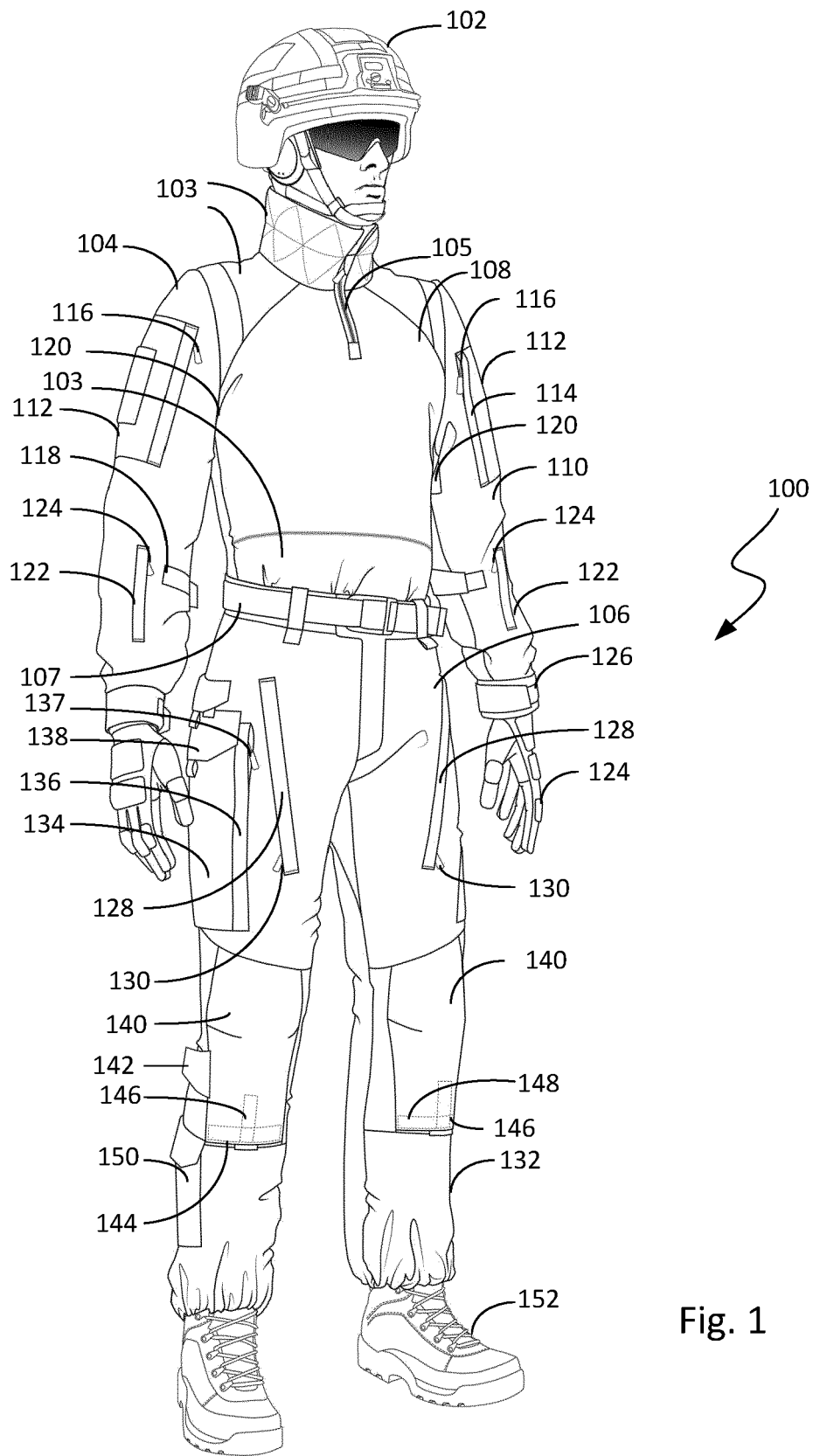

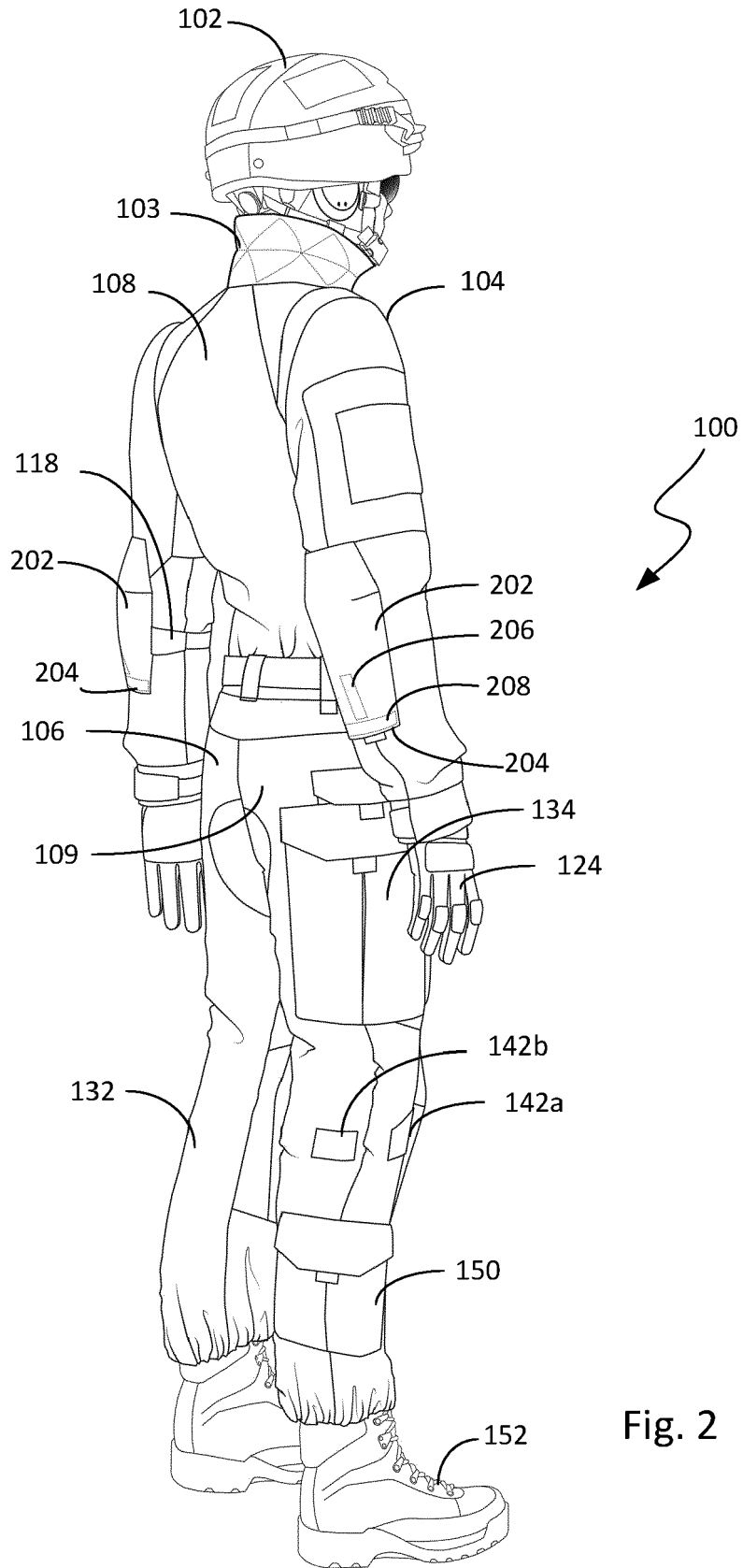

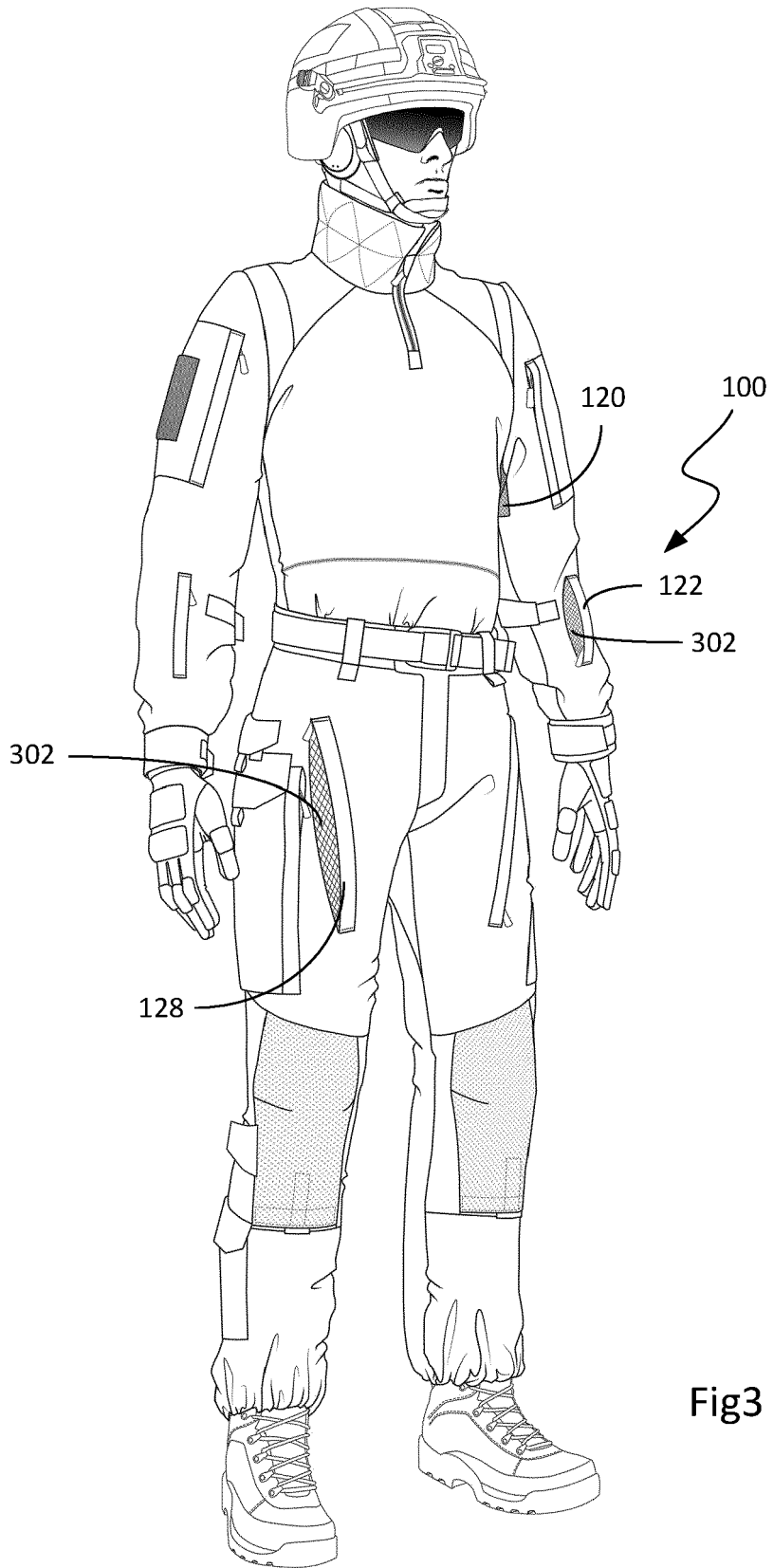

Fig3 .

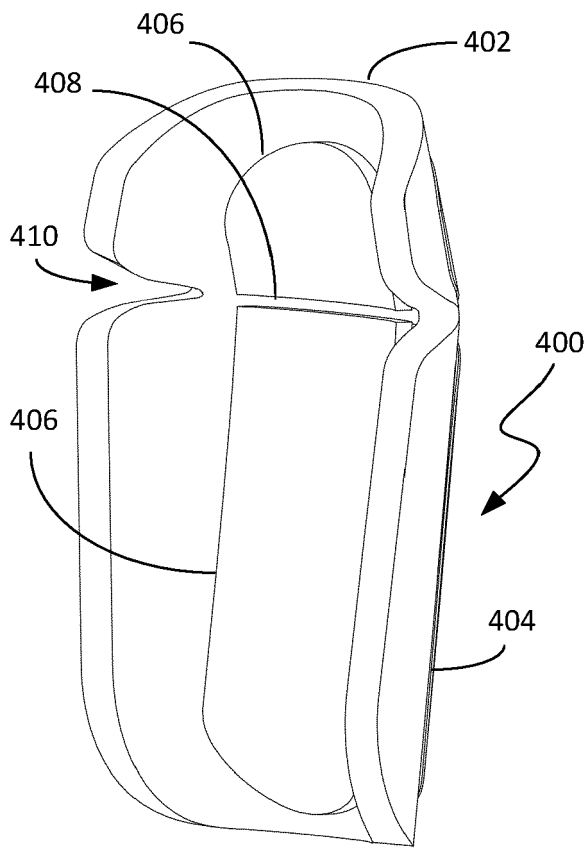

Fig. 4A

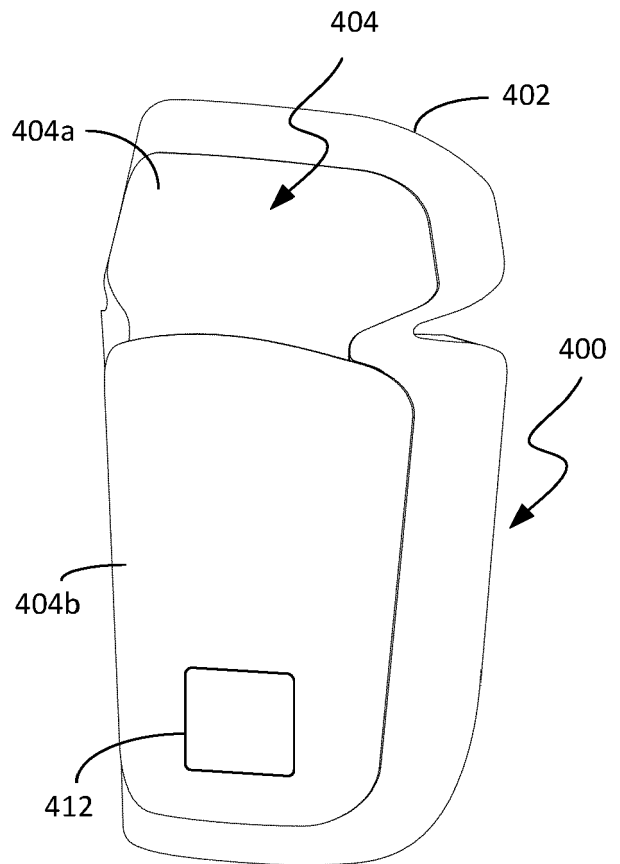

Fig. 4B

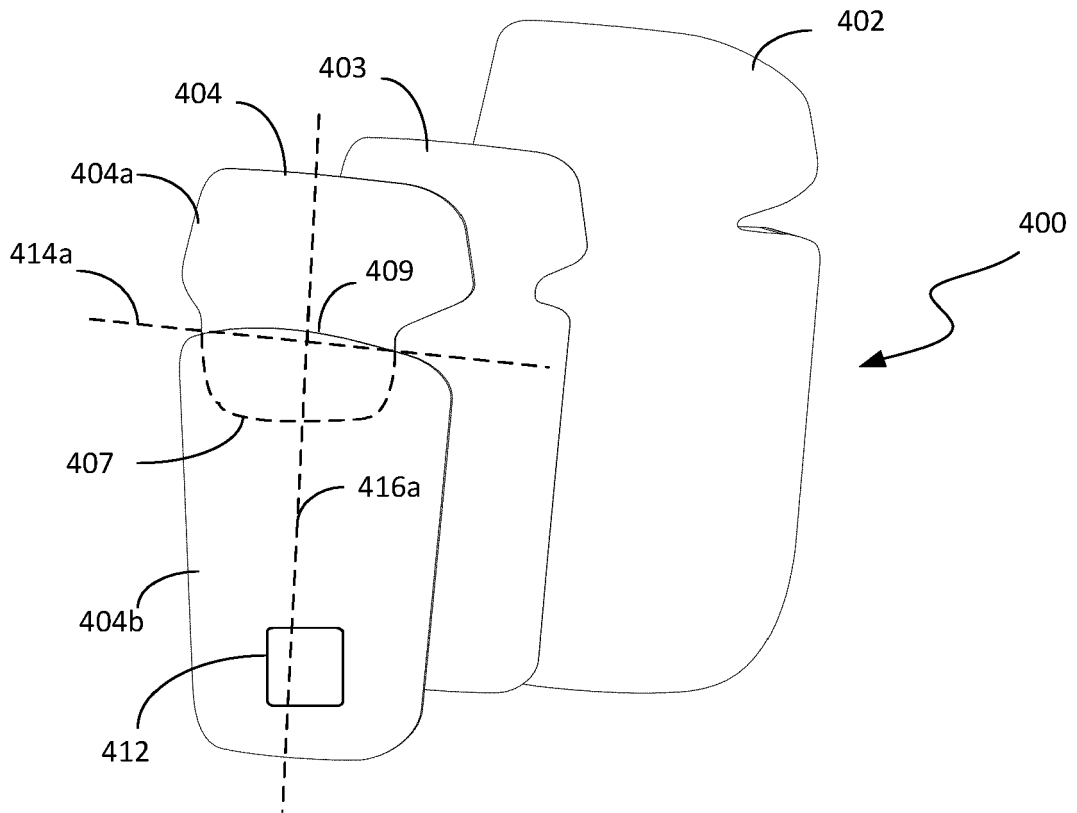

Fig. 4C

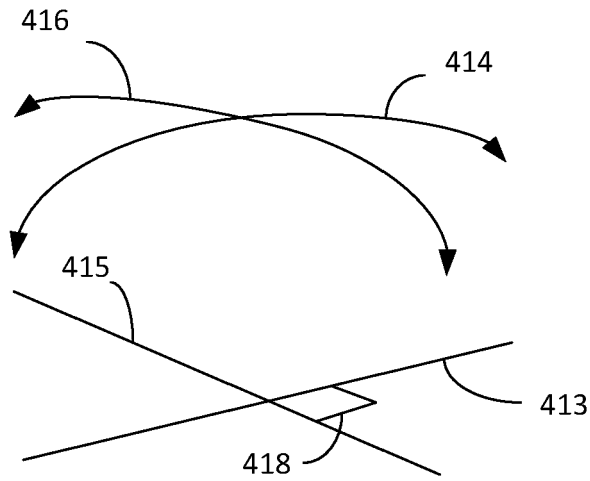

Fig. 4D

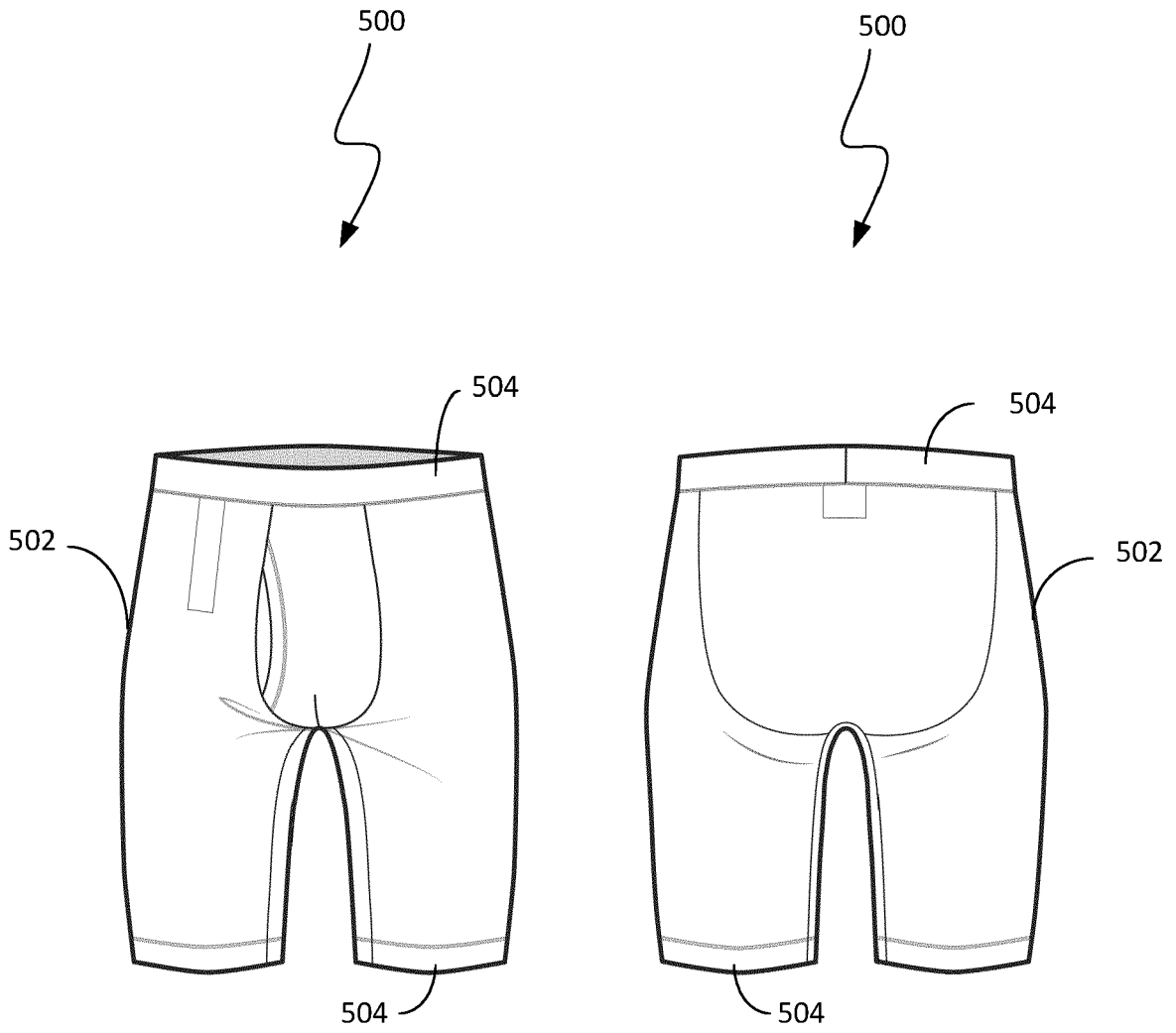

Fig. 5A

Fig. 5B



EUROPEAN SEARCH REPORT

Application Number

EP 22 18 9606

5

DOCUMENTS CONSIDERED TO BE RELEVANT

10

15

20

25

30

35

40

45

Category	Citation of document with indication, where appropriate, of relevant passages	Relevant to claim	CLASSIFICATION OF THE APPLICATION (IPC)
X	US 2014/259324 A1 (BEHREND CARL [US] ET AL) 18 September 2014 (2014-09-18)	1-3, 5, 8-11	INV. A41D13/015
Y	* paragraph [0015] - paragraph [0067]; figures 1-10 *	4, 6, 7	
Y	----- US 2013/269075 A1 (BOYE PHILIPPE [FR]) 17 October 2013 (2013-10-17) * paragraph [0032] - paragraph [0068]; figures 1-3 *	4, 6, 7	
X	----- WO 2014/068212 A1 (ACTIMAGE [FR]) 8 May 2014 (2014-05-08) * page 6, line 10 - page 8, line 29; figures 1-6 *	1	
			TECHNICAL FIELDS SEARCHED (IPC)
			A41D

1

The present search report has been drawn up for all claims

50

Place of search Munich	Date of completion of the search 9 November 2022	Examiner Arboreanu, Antoniu
----------------------------------	--	---------------------------------------

55

EPO FORM 1503 03.82 (P04C01)

CATEGORY OF CITED DOCUMENTS
 X : particularly relevant if taken alone
 Y : particularly relevant if combined with another document of the same category
 A : technological background
 O : non-written disclosure
 P : intermediate document

T : theory or principle underlying the invention
 E : earlier patent document, but published on, or after the filing date
 D : document cited in the application
 L : document cited for other reasons

 & : member of the same patent family, corresponding document

**ANNEX TO THE EUROPEAN SEARCH REPORT
ON EUROPEAN PATENT APPLICATION NO.**

EP 22 18 9606

5 This annex lists the patent family members relating to the patent documents cited in the above-mentioned European search report.
The members are as contained in the European Patent Office EDP file on
The European Patent Office is in no way liable for these particulars which are merely given for the purpose of information.

09-11-2022

Patent document cited in search report	Publication date	Patent family member(s)	Publication date
US 2014259324 A1	18-09-2014	CN 105025740 A	04-11-2015
		EP 2967166 A1	20-01-2016
		JP 6170612 B2	26-07-2017
		JP 2016516915 A	09-06-2016
		US 2014259324 A1	18-09-2014
		WO 2014159086 A1	02-10-2014

US 2013269075 A1	17-10-2013	EP 2635143 A1	11-09-2013
		FR 2966702 A1	04-05-2012
		US 2013269075 A1	17-10-2013
		WO 2012059462 A1	10-05-2012

WO 2014068212 A1	08-05-2014	FR 2997269 A1	02-05-2014
		WO 2014068212 A1	08-05-2014

EPO FORM P0459

For more details about this annex : see Official Journal of the European Patent Office, No. 12/82