



US 20040143926A1

(19) **United States**

(12) **Patent Application Publication**
Ramirez

(10) **Pub. No.: US 2004/0143926 A1**

(43) **Pub. Date: Jul. 29, 2004**

(54) **AUTOMATIC ROLLER WRINGER FOR
MOPS AND THE LIKE**

Publication Classification

(76) **Inventor: Jose Damian Ramirez**, Chiclana de la
Frontera (Cadiz) (ES)

(51) **Int. Cl.⁷ A47L 13/60**

(52) **U.S. Cl. 15/262**

Correspondence Address:

BAKER BOTTS LLP
C/O INTELLECTUAL PROPERTY
DEPARTMENT
THE WARNER, SUITE 1300
1299 PENNSYLVANIA AVE, NW
WASHINGTON, DC 20004-2400 (US)

(57)

ABSTRACT

An automatic roller wringer for mops and the like, consisting of the incorporation of the main gears (12) inside the casing (2), one of the gears being provided with a projection (13) for the stop, the main gears being asymmetrically assembled on either side, engaging with the fixed roller (5), each one of the main gears (12) being provided with an eccentric guide on the inner part through which the pivots of the movable roller (7) pass until the latter is in a position adjacent to the fixed roller (5), which upwardly rotates, the arms supporting the pivots of the arm of the movable roller (7) being provided with a spring on each one.

(21) **Appl. No.: 10/758,526**

(22) **Filed: Jan. 16, 2004**

(30) **Foreign Application Priority Data**

Jan. 16, 2003 (ES) 200300104

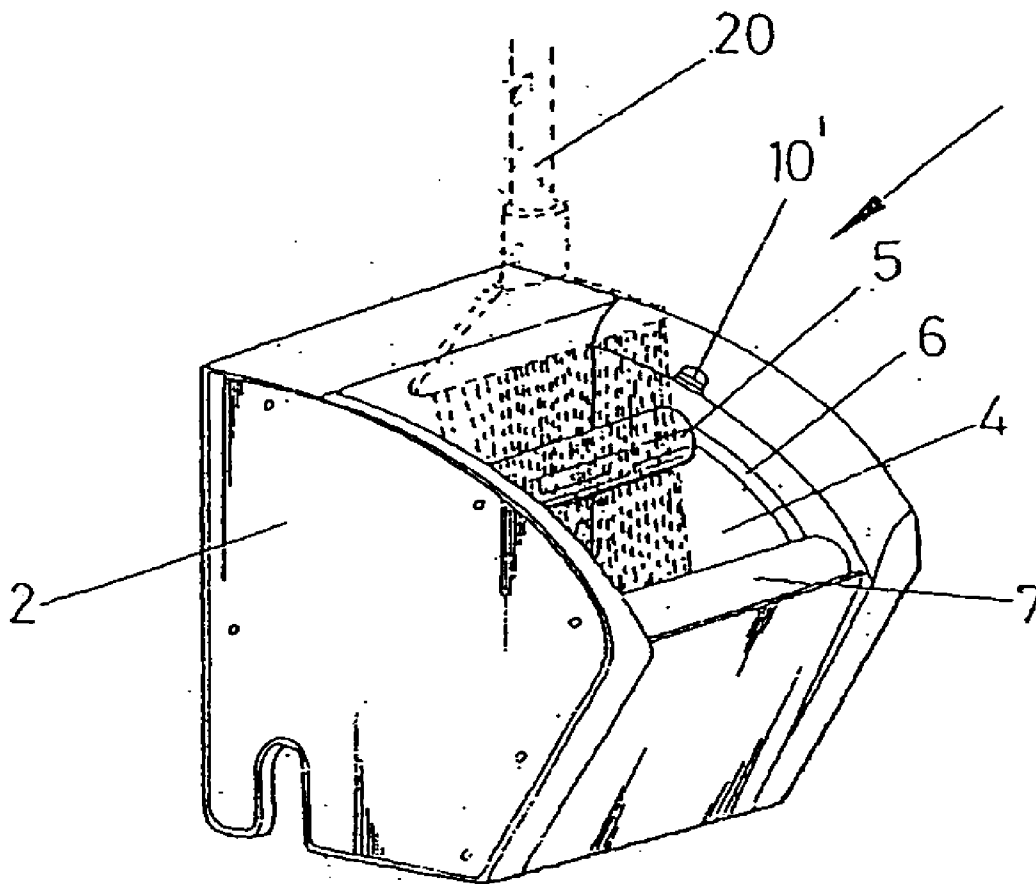

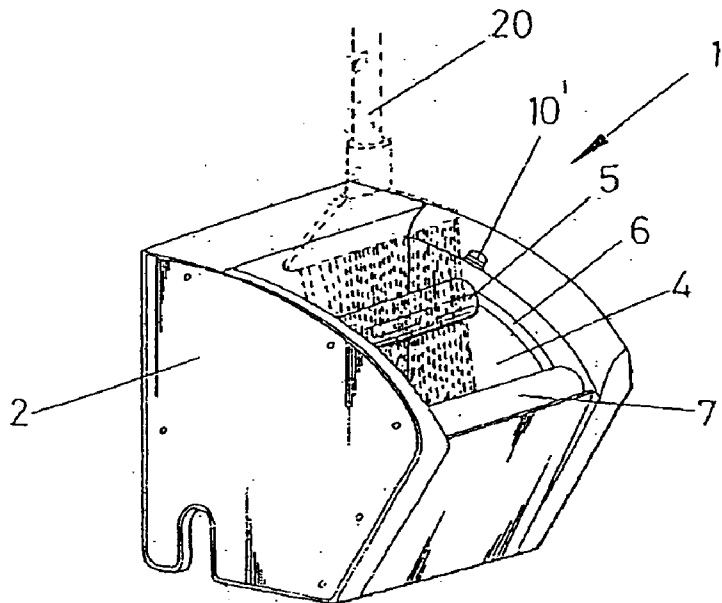

FIG. 1

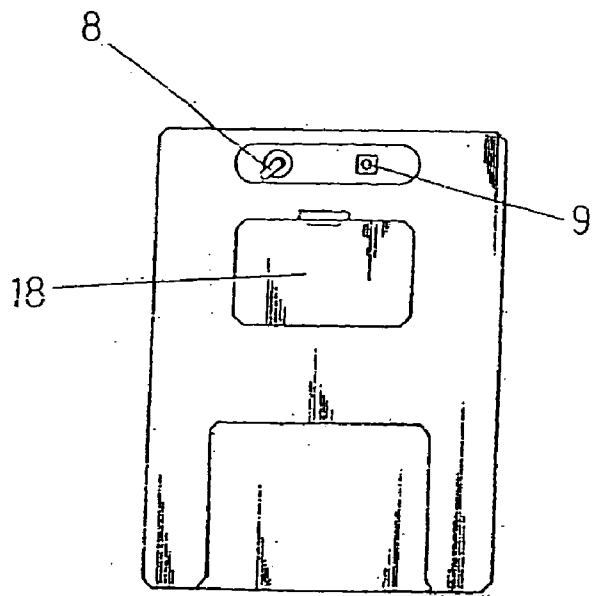

FIG. 2

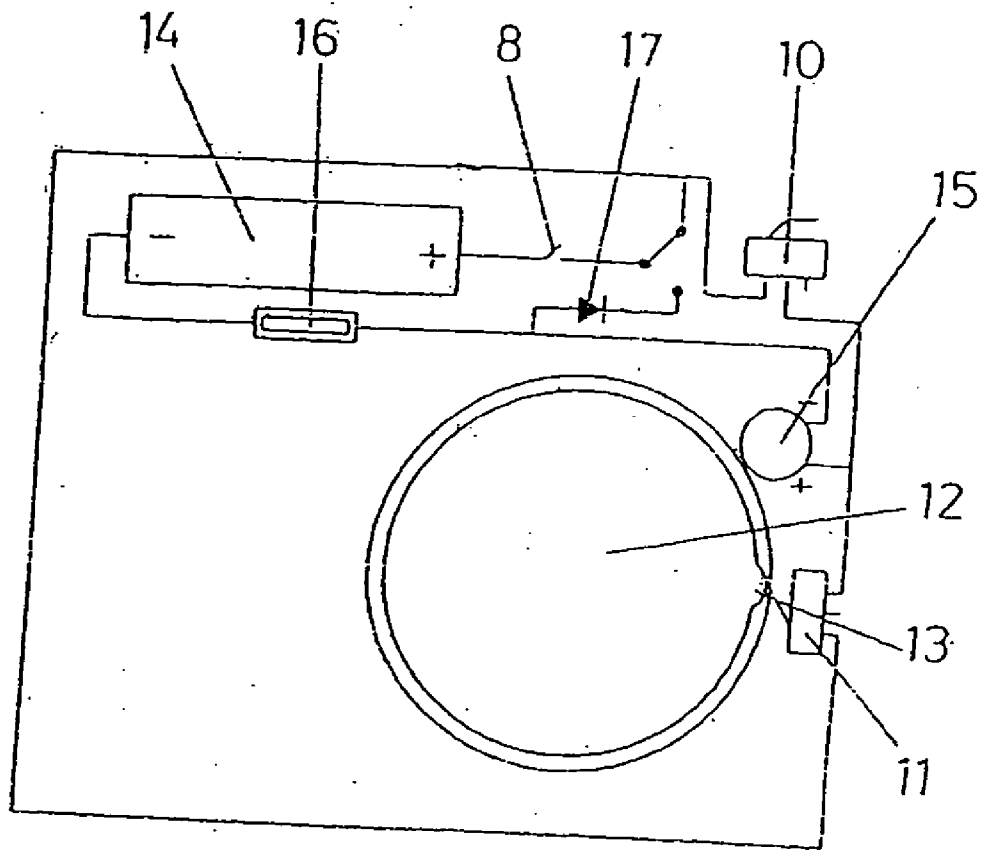

FIG. 3

AUTOMATIC ROLLER WRINGER FOR MOPS AND THE LIKE

OBJECT OF THE INVENTION

[0001] The present specification refers to a Patent application regarding an automatic roller wringer for mops and the like which mops can be replaced by floor scrubbing devices, butts of the handle, etc., the purpose of which is to facilitate the significant reduction of the effort made by those persons who perform the job of wringing the mop for cleaning floors, or of any similar element, automatically performing the wringing of the mop or the like located on the lower part of the mop handle.

FIELD OF THE INVENTION

[0002] This invention is applicable within the industry dedicated to the manufacture of domestic and industrial cleaning apparatuses, especially within the industry dedicated to the manufacture of automatic wringers or similar apparatuses.

BACKGROUND OF THE INVENTION

[0003] The applicant knows of the existence of several apparatuses, devices or elements applicable as wringers which are provided with mechanical actuation elements, operated by the user or users of these elements, configured from clamps, rollers or coupling elements which, directly operated by the user by means of a crank or the like, achieve removing the water contained by the mops or the like.

[0004] The applicant likewise knows of the current existence of a plurality of supports having a similar application, provided with mops or the like whose wringing operation is manually performed by introducing the end of the handle of the floor scrubbing device or the like into frustoconical shaped inverted baskets which, by means of twisting movements, removes the liquid contained in the mop.

[0005] The applicant knows of the current existence of some carts incorporating the body of a recipient on their structure, on which recipient an electric-power supplied wringer is assembled, the feed of which originates from a battery or an accumulator, the body of the wringer being placed on the surface of the recipient bucket, which in turn is provided with a second compartment with clean water, falling to the inside of the compartment adjacent to the clean water container, which may or may not contain a cleaning product, a second compartment on the inside of which the water from the wringing operation slowly falls into.

[0006] It must be indicated that these wringing elements are provided with two blades located in opposing points which, when the drive motor thereof is actuated, generate a transportation movement in a coinciding direction, generating the wringing of the mop or the like previously placed between the two movable parts, a movement which automatically stops when the parts generating the mobilization of both wringing areas has carried out its cycle, returning to the standstill position, i.e. separating from one another and allowing the removal of the mop or butt of the handle through the upper part.

[0007] It has been shown that these parts which move like blades or the like, generating an approaching movement, do not definitively wring the mop or the like, as a result of

which the user must actuate them on several occasions, on one hand leading to a loss of time, as well as a large use of electric power accumulated in the battery.

[0008] In view of this drawback, it would be necessary to provide an automatic wringer with incorporated internal transversally arranged rollers in replacement of the blades, rollers which, provided with rotating capacity as well as movement, suitably achieve removing the water existing in the mop or the like.

[0009] However, the applicant does not know of the current existence of an invention provided with the features indicated above as suitable.

DESCRIPTION OF THE INVENTION

[0010] The automatic roller wringer for mops and the like proposed by the invention is a novelty element itself, providing within its context all those features defined as solutions to the evident drawbacks in this matter.

[0011] More specifically, the automatic roller wringer for mops and the like object of the invention is constituted of a heavy-duty bucket provided with wheels which facilitate transporting it, on which bucket the automatic roller wringer for mops and the like is supported, internally incorporating different mechanisms which achieve that it acts automatically, without needing to have an external power source.

[0012] On the inside of the casing forming the wringer, one or two motors has been provided which are fed by an electric battery arranged inside the casing, which battery is fed until it is saturated by means of the use of a conventional battery charger which is connected to the electric system by one of its ends, and the other one of the ends existing in the charger is incorporated to a base located in the rear part of the casing constituting the wringer, thereby feeding the battery and performing the relevant charging with this operation.

[0013] A main switch which starts up the operation or stops the actuation of the wringer has been provided on the outer area of the structure of the wringer, which switch is provided with an automatic thermal protection element.

[0014] A projection is provided on the side area of the front face of the wringer, on which projection a switch is incorporated which is operated by the mop handle when it is placed along it in a downward direction, the actuation of this switch generating the start-up of the entire mechanism, achieving that one of the rollers begins rotating and the opposite roller moves while it is rotating until it is adjacent to the fixed rotating roller, which, with the pressure generated between both rollers, leads to the complete wringing of the mop.

DESCRIPTION OF THE DRAWINGS

[0015] To complement the description that is being made and for the purpose to aid a better understanding of the features of the invention, two sheets of drawings are attached to the present specification as an integral part thereof which, with an illustrative and non-limiting character, show the following:

[0016] **FIG. 1** shows a perspective view from the front, upper area of the invention regarding an automatic roller wringer for mops and the like.

[0017] FIG. 2 shows a rear elevational view of the object shown in FIG. 1.

[0018] FIG. 3 shows a block diagram of the elements incorporated on the inside of the object of the invention, shown in FIGS. 1 and 2.

PREFERRED EMBODIMENT OF THE INVENTION

[0019] In view of these figures, it can be seen how the automatic roller wringer for mops and the like object of the invention is constituted of a casing (2), there being arranged on the lower part thereof coupling elements for arranging on a support bucket, and the front central area thereof being completely hollow, except for the existence of two transversal rollers (5) and (7), roller (5) being fixed but provided with rotational movement, whereas roller (7) is movable, shifting on two side guides (6) arranged on the inner area (4) of the casing (2), the movable roller (7) being operated and started up by means of the user's direct actuation with the end of the handle (20) of the mop or the like on an external switch (10') existing in a groove or suitable area on the right side of the upper part of the casing (2).

[0020] The movement of the rollers (5) and (7) is performed due to the existence of one or two main gears (12) provided with an eccentric guide on the inner part, through which guide the pivots of the movable arm pass which make the roller (7) advance and press against the mop at the same time that the roller (5) is rotating in an upward direction, a rotation carried out for a predetermined time applicable for carrying out the entire run of the length of the mop or the like, pushing the totally wrung mop (20) out through the upper part, the roller (7) returning to its original position once the wringing has concluded.

[0021] The arms supporting the roller (7) are provided with the relevant springs, which results in a certain resilience of the roller (7), since it permits the latter to adapt to the different types and thicknesses of mops, butts of handles, floor scrubbing devices, etc.

[0022] The start-up is carried out by means of the main external switch (8), but the movement is carried out by letting the mop (20) fall into the gap existing in the upper right-hand area, generating the mobilization of the push button or switch (10'), making the motor (15) rotate the time which is necessary until the micro (11) is actuated, and accordingly feeding the circuit during the entire run, the stop being carried out by means of a projection (13) existing on the main gears (12) which actuate the micro (11), it being necessary to indicate that the entire wringing process is carried out in a single rotation of said main gears (12), the circuit being open and prepared for a subsequent wringing or actuation.

[0023] The automatic wringer (1) is provided on its rear part with a main switch (8), as well as a charging connection (9) for charging the battery, the circuit being open during the charge time, a circuit which is provided with a polarizing diode (17) as a security means, as well as a thermal element (16) serving as protection for the entire electric circuit.

[0024] The battery has been referenced with (14), and the internal push button with (10), which push button acts in collaboration with external push button (10'), making the motor rotate.

[0025] An access door (18) constituting the cover of the battery has been provided on the rear part.

1. An automatic roller wringer for mops and the like, of those constituted of an external casing (2) which is provided with a front, central hollow area (4), provided with means for being adapted on a bucket or the like provided with wheels, there being in the rear area a switch (8) and a charging connection (9) for connecting a battery charger, a door (18) or cover for the battery box being arranged, characterized in that one or two motors (15), as well as a series of gears, are incorporated inside the casing (2), the motors being fed from one or several batteries or accumulators (15), having two asymmetrical arms on either side, and two transversal rollers (5) and (7) arranged in the hollow area (4), roller (7) shifting until coinciding with roller (5) by means of two projecting lugs connected to the arms, the lugs resting on two parallel guides (6) arranged on the inner faces of the hollow area (4), roller (5) rotating but remaining fixed in the point in which it is located.

2. An automatic roller wringer for mops and the like according to claim 1, characterized by being provided with two main gears (12) asymmetrically assembled on either side, engaging with roller (5), the main gears (12) being provided with an eccentric guide on the lower part of each one of them through which the pivots of the movable arms pass, which arms generate the advance and pressure of the roller (7) on the mop and on the fixed roller (5) which upwardly rotates along the entire length of the mop, the roller (7) returning to its standstill position.

3. An automatic roller wringer for mops and the like according to the previous claims, characterized in that the part of the arms which support the roller (7) are provided with a spring on each one of the arms, starting up by means of the main switch (8), with the collaboration of the external actuator (10') generating the start up of the internal actuator or push button (10), the motor maintaining rotation until the microcontroller (11) determines the stop of the motors and carries out the feeding of the circuit in the entire run.

4. An automatic roller wringer for mops and the like according to the previous claims, characterized in that one of the main gears (12) is provided with a projection (13) which generates the operation of the microswitch (11).

5. An automatic roller wringer for mops and the like according to the previous claims, characterized in that the wringing process is generated with a single rotation of the main gears (12), the circuit thereby being open.

6. An automatic roller wringer for mops and the like according to the previous claims, characterized by being provided with a polarizing diode (17) and a thermal element (16).

* * * * *