

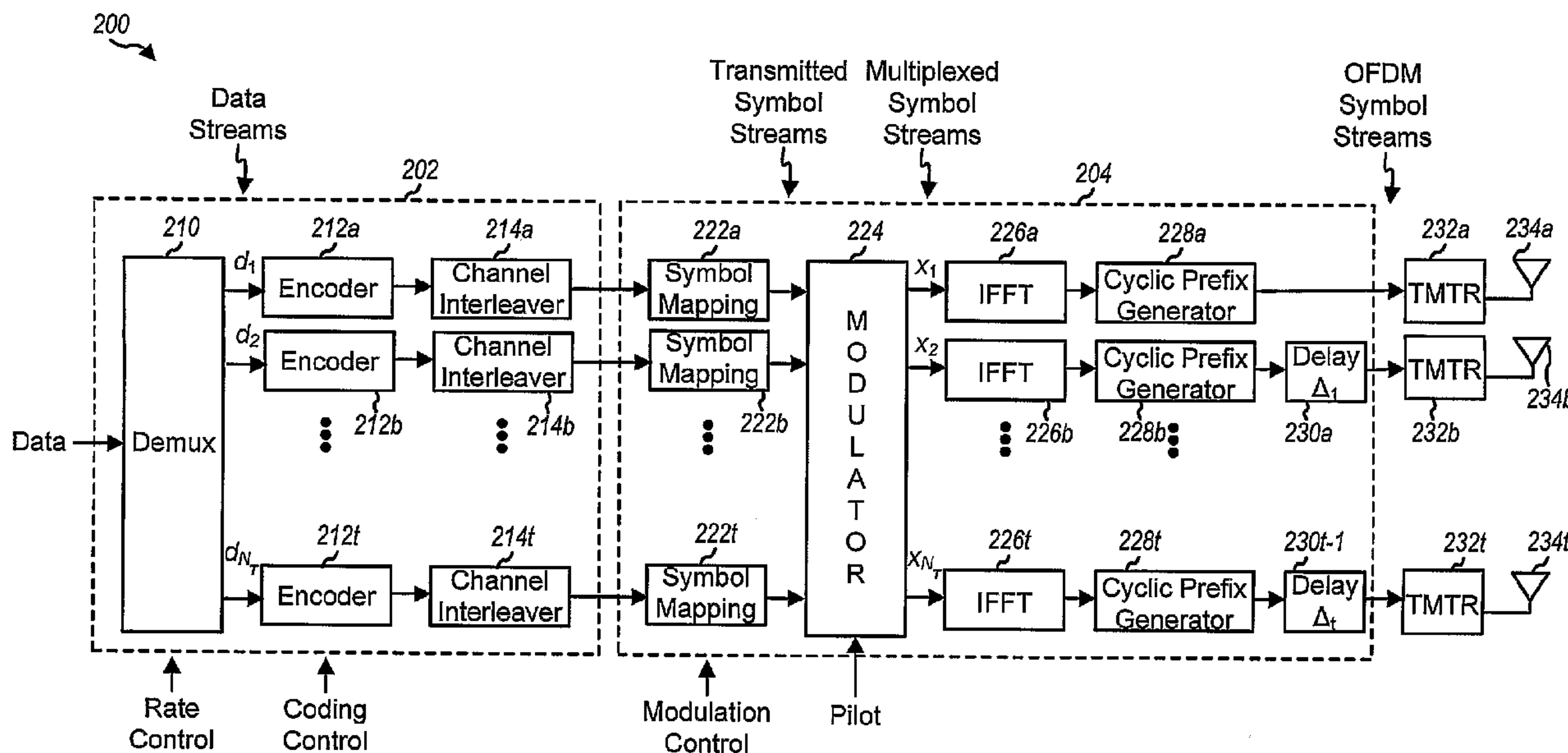

(86) Date de dépôt PCT/PCT Filing Date: 2005/04/29
 (87) Date publication PCT/PCT Publication Date: 2005/12/08
 (45) Date de délivrance/Issue Date: 2011/10/04
 (85) Entrée phase nationale/National Entry: 2006/11/09
 (86) N° demande PCT/PCT Application No.: US 2005/015041
 (87) N° publication PCT/PCT Publication No.: 2005/117321
 (30) Priorités/Priorities: 2004/05/17 (US60/572,137);
 2005/03/10 (US11/078,176)

(51) Cl.Int./Int.Cl. *H04L 1/06* (2006.01),
H04B 7/06 (2006.01)
 (72) Inventeurs/Inventors:
 NAGUIB, AYMAN FAWZY, US;
 AGRAWAL, AVNEESH, US
 (73) Propriétaire/Owner:
 QUALCOMM INCORPORATED, US
 (74) Agent: SMART & BIGGAR

(54) Titre : DIVERSITE DE RETARD CYCLIQUE VARIABLE DANS LE TEMPS D'OFDM
 (54) Title: TIME VARYING CYCLIC DELAY DIVERSITY OF OFDM



(57) Abrégé/Abstract:

Methods and apparatuses that apply a time-varying delay to symbols to be transmitted from one or more antennas are provided.

(12) INTERNATIONAL APPLICATION PUBLISHED UNDER THE PATENT COOPERATION TREATY (PCT)

(19) World Intellectual Property Organization
International Bureau



(43) International Publication Date
8 December 2005 (08.12.2005)

PCT

(10) International Publication Number
WO 2005/117321 A1

(51) International Patent Classification⁷: H04L 1/06, H04B 7/06

(21) International Application Number: PCT/US2005/015041

(22) International Filing Date: 29 April 2005 (29.04.2005)

(25) Filing Language: English

(26) Publication Language: English

(30) Priority Data:
60/572,137 17 May 2004 (17.05.2004) US
11/078,176 10 March 2005 (10.03.2005) US

(71) Applicant (for all designated States except US): QUALCOMM INCORPORATED [US/US]; 5775 Morehouse Drive, San Diego, CA 92121 (US).

(72) Inventors; and

(75) Inventors/Applicants (for US only): NAGUIB, Ayman, Fawzy [EG/US]; 991 Cranberry Drive, Cupertino, CA 95014 (US). AGRAWAL, Avneesh [IN/US]; 7891 Doug Hill, San Diego, CA 92127 (US).

(74) Agents: OGROD, Gregory, D. et al.; 5775 Morehouse Drive, San Diego, CA 92121 (US).

(81) Designated States (unless otherwise indicated, for every kind of national protection available): AE, AG, AL, AM, AT, AU, AZ, BA, BB, BG, BR, BW, BY, BZ, CA, CH, CN, CO, CR, CU, CZ, DE, DK, DM, DZ, EC, EE, EG, ES, FI, GB, GD, GE, GH, GM, HR, HU, ID, IL, IN, IS, JP, KE,

KG, KM, KP, KR, KZ, LC, LK, LR, LS, LT, LU, LV, MA, MD, MG, MK, MN, MW, MX, MZ, NA, NI, NO, NZ, OM, PG, PH, PL, PT, RO, RU, SC, SD, SE, SG, SK, SL, SM, SY, TJ, TM, TN, TR, TT, TZ, UA, UG, US, UZ, VC, VN, YU, ZA, ZM, ZW.

(84) Designated States (unless otherwise indicated, for every kind of regional protection available): ARIPO (BW, GH, GM, KE, LS, MW, MZ, NA, SD, SL, SZ, TZ, UG, ZM, ZW), Eurasian (AM, AZ, BY, KG, KZ, MD, RU, TJ, TM), European (AT, BE, BG, CH, CY, CZ, DE, DK, EE, ES, FI, FR, GB, GR, HU, IE, IS, IT, LT, LU, MC, NL, PL, PT, RO, SE, SI, SK, TR), OAPI (BF, BJ, CF, CG, CI, CM, GA, GN, GQ, GW, ML, MR, NE, SN, TD, TG).

Declarations under Rule 4.17:

— as to applicant's entitlement to apply for and be granted a patent (Rule 4.17(ii)) for the following designations AE, AG, AL, AM, AT, AU, AZ, BA, BB, BG, BR, BW, BY, BZ, CA, CH, CN, CO, CR, CU, CZ, DE, DK, DM, DZ, EC, EE, EG, ES, FI, GB, GD, GE, GH, GM, HR, HU, ID, IL, IN, IS, JP, KE, KG, KM, KP, KR, KZ, LC, LK, LR, LS, LT, LU, LV, MA, MD, MG, MK, MN, MW, MX, MZ, NA, NI, NO, NZ, OM, PG, PH, PL, PT, RO, RU, SC, SD, SE, SG, SK, SL, SM, SY, TJ, TM, TN, TR, TT, TZ, UA, UG, UZ, VC, VN, YU, ZA, ZM, ZW, ARIPO patent (BW, GH, GM, KE, LS, MW, MZ, NA, SD, SL, SZ, TZ, UG, ZM, ZW), Eurasian patent (AM, AZ, BY, KG, KZ, MD, RU, TJ, TM), European patent (AT, BE, BG, CH, CY, CZ, DE, DK, EE, ES, FI, FR, GB, GR, HU, IE, IS, IT, LT, LU, MC, NL, PL, PT, RO, SE, SI, SK, TR), OAPI patent (BF, BJ, CF, CG, CI, CM, GA, GN, GQ, GW, ML, MR, NE, SN, TD, TG)

[Continued on next page]

(54) Title: TIME VARYING CYCLIC DELAY DIVERSITY OF OFDM

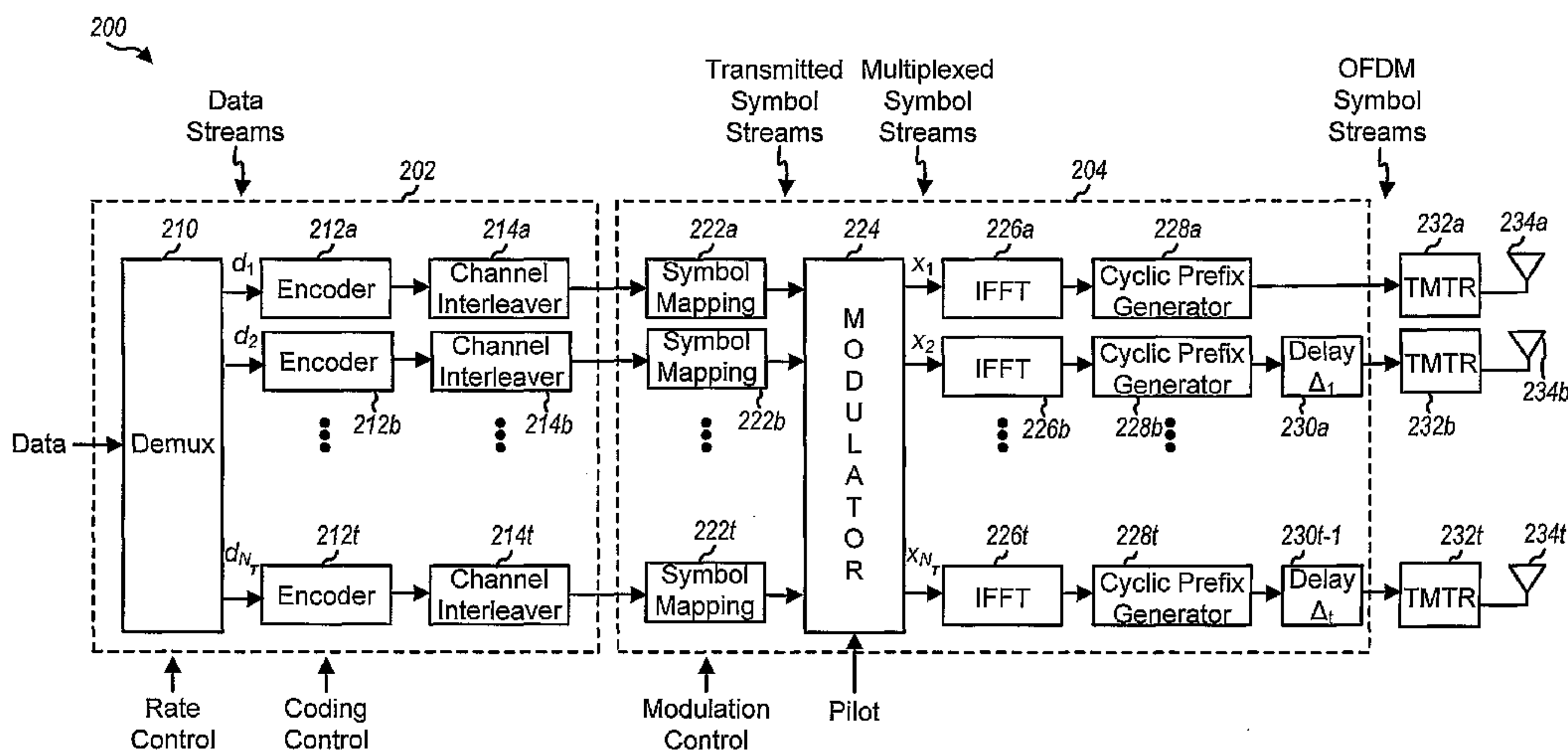

(57) Abstract: Methods and apparatuses that apply a time-varying delay to symbols to be transmitted from one or more antennas are provided.

WO 2005/117321 A1

WO 2005/117321 A1



-
- *as to the applicant's entitlement to claim the priority of the earlier application (Rule 4.17(iii)) for all designations*
 - *as to the applicant's entitlement to claim the priority of the earlier application (Rule 4.17(iii)) for all designations*

For two-letter codes and other abbreviations, refer to the "Guidance Notes on Codes and Abbreviations" appearing at the beginning of each regular issue of the PCT Gazette.

Published:

- *with international search report*

TIME VARYING CYCLIC DELAY DIVERSITY OF OFDM

BACKGROUND

Field

[0002] The present document relates generally to wireless communication, and amongst other things to, signal transmission in multi-antenna system.

Background

[0003] In a wireless communication system, an RF modulated signal from a transmitter may reach a receiver via a number of propagation paths. The characteristics of the propagation paths typically vary over time due to a number of factors such as fading and multipath. To provide diversity against deleterious path effects and improve performance, multiple transmit and receive antennas may be used. A multiple-input multiple-output (MIMO) communication system employs multiple (N_T) transmit antennas and multiple (N_R) receive antennas for data transmission. A MIMO channel formed by the N_T transmit and N_R receive antennas may be decomposed into N_S independent channels, with $N_S \leq \min \{N_T, N_R\}$. Each of the N_S independent channels may also be referred to as a spatial subchannel (or a transmission channel) of the MIMO channel and corresponds to a dimension.

[0004] If the propagation paths between the transmit and receive antennas are linearly independent (i.e., a transmission on one path is not formed as a linear combination of the transmissions on the other paths), which is generally true to at least an extent, then the likelihood of correctly receiving a data transmission increases as the number of antennas increases. Generally, diversity increases and performance improves as the number of transmit and receive antennas increases

[0005] To further improve the diversity of the channels a transmit diversity technique may be utilized. Many transmit diversity techniques have been explored. One such technique is transmit delay diversity. In transmit delay diversity a transmitter utilizes two antennas that transmit the same signal, with the second antenna transmitting a delayed replica of that transmitted by the first antenna. By so doing, the second antenna creates diversity by establishing a second set of independent multipath elements that may be collected at the receiver. If the multipath generated by the first transmitter fades, the multipath generated by the second transmitter may not, in which case an acceptable Signal-To-Noise Ratio (SNR) will be maintained at the receiver. This technique is easy to implement, because only the composite TX0+TX1 channel is estimated at the receiver. The biggest drawback to transmit delay diversity is that it increases the effective delay spread of the channel, and can perform poorly when the multipath introduced by the second antenna falls upon, and interacts destructively with, the multipath of the first antenna, thereby reducing the overall level of diversity.

[0006] To deal with standard delay diversity problems, additional delay diversity techniques have been developed. One such technique is referred to as cyclic delay diversity. A cyclic delay is one where the samples of each symbol of the n_i symbols are shifted in the order in which they are transmitted as part of the symbol. Those samples that are beyond the effective part of the symbol are transmitted in the beginning of that symbol. In such a technique, a prefix is pre-pended to each sample that fixes a delay, or order, for transmitting the sample from the specific antenna as part of the symbol. The cyclic delays allow for longer delays, however, which would otherwise be limited to fractions of the guard interval period to avoid inter-symbol interference.

[0007] A cyclic delay diversity scheme may introduce frequency selectivity in the channel and hence may provide diversity benefit for flat channels. It does not provide, however, any time diversity when the channel is not in and of itself time selective. For example, if two transmit antennas are in slow fading or static channels, the cyclic shift Δ_m may be such that the two channels, e.g. $H_1(n)$ and $H_2(n)$, add up destructively (or constructively) all the time.

[0008] Therefore, it is desired to provide a delay diversity scheme which minimizes the possibility of destructive or constructive addition of the channels utilized to provide diversity.

SUMMARY

[0009] In one aspect, a method for providing transmission diversity comprises providing, to a first antenna, a first symbol after a first delay period, providing, to the first antenna, a second symbol after a second delay period that is different than the first delay period, and providing, to the first antenna, a third symbol after a third delay period that is different than the first delay period and the second delay period.

[0010] In another aspect, a transmitter comprises at least two antennas, a modulator, and a delay circuit that delays symbols output from the modulator to the antenna by a delay period that varies over time.

[0011] In an additional aspect, a wireless transmitter comprises at least two antennas and a that stores a plurality of symbols each comprising a plurality of samples, wherein the memory outputs the plurality of samples of a first symbol after a first delay to one antenna of the at least two antennas and a second symbol of the plurality of symbols after a second delay to the one antenna. The first delay and the second delay are different.

[0012] In a further aspect, a transmitter comprises at least three antennas, a modulator, a first delay circuit coupled between the modulator and one of the at least two antennas, the first delay circuit delaying symbols output from the modulator to the antenna by a delay period that varies over time, and a second delay circuit coupled between the modulator and another of the at least two antennas, the first delay circuit delaying symbols output from the modulator to the another antenna by a another delay period that varies over time. The another delay period and the delay period are different.

[0013] In yet another aspect, a method for providing transmission diversity in a multi-channel communication system comprises applying a first phase shift to a first symbol to be transmitted on a first antenna and applying a second phase shift, different than the first phase shift, to the first symbol to be transmitted on a second antenna.

74769-1518

4

[0014] In yet a further aspect, a transmitter comprises at least two antennas, a modulator, and a phase shift that applies a phase shift to symbols output by the modulator to the antenna by a phase shift that varies over time.

[0014a] According to another aspect, there is provided a method for providing transmission diversity in a multi-channel communication system comprising: providing to a first antenna a first symbol comprising a first plurality of samples; providing to a second antenna the first symbol after a first delay period; providing to the first antenna a second symbol comprising a second plurality of samples; providing to the second antenna the second symbol after a second delay period that is different than the first delay period; providing to the first antenna a third symbol comprising a third plurality of samples; providing to the second antenna the third symbol after a third delay period that is different than the first delay period and the second delay period, wherein the first delay period comprises a delay of X sample periods, the second delay period comprises a delay of Y sample periods which is any number of sample periods other than X , and the third delay period comprises a delay of Z sample periods which is any number of sample periods other than X or Y , and wherein the first delay period, the second delay period, and the third delay period are independent of feedback information on channel conditions.

[0014b] According to still another aspect, there is provided an apparatus for providing transmission diversity in a multi-channel communication system comprising: at least two antennas a modulator coupled with the at least two antennas; and means for providing delay coupled between the modulator and one of the at least two antennas, the means for providing delay configured to delay symbols output from the modulator to the antenna by a delay period, wherein the means for providing delay provides the delay period so that it is different between consecutive symbols by a number of sample periods that is equal to a constant multiplied by a varying number corresponding to the location of the symbol, and wherein the first delay period, the second delay period, and the third delay period are independent of feedback information on channel conditions.

[0014c] According to yet another aspect, there is provided a computer-readable medium having computer-executable instructions stored thereon that,

74769-1518

4a

when executed by a computer, cause the computer to perform the method as described above or below.

BRIEF DESCRIPTION OF THE DRAWINGS

- [0015]** The features, nature, and advantages of the present invention will
5 become more apparent from the detailed description set forth below when taken in
conjunction with the drawings in which like reference characters identify
correspondingly throughout and wherein:
- [0016]** FIG. 1 illustrates a block diagram of an embodiment of a transmitter
system and a receiver system in a MIMO system;
- 10 **[0017]** FIG. 2 illustrates a block diagram of an embodiment of a transmitter
unit that provides time-varying delay diversity;
- [0018]** FIG. 3 illustrates an embodiment of a time varying delay applied to
symbols transmitted from a same antenna;
- [0019]** FIG. 4 illustrates an embodiment of a time varying delay applied to a
15 symbol transmitted on multiple antenna;
- [0020]** FIG. 5 illustrates a block diagram of another embodiment of a
transmitter unit that provides time-varying delay diversity;
- [0021]** FIG. 6 illustrates a block diagram of an embodiment of a receiver
unit capable of utilizing time-varying delay diversity;
- 20 **[0022]** FIG. 7 illustrates a block diagram of an embodiment of a delay
element;
- [0023]** FIG. 8 illustrates a flow chart of an embodiment of a method for
providing time-varying diversity;
- [0024]** FIG. 9 illustrates a block diagram of a further embodiment of a
25 transmitter unit that provides time-varying delay diversity; and
- [0025]** FIG. 10 illustrates a flow chart of a further embodiment of a method
for providing time-varying diversity.

74769-1518

4b

DETAILED DESCRIPTION

[0026] The detailed description set forth below in connection with the appended drawings is intended as a description of exemplary embodiments and is not intended to represent the only embodiments in which the present

invention can be practiced. The term “exemplary” used throughout this description means “serving as an example, instance, or illustration,” and should not necessarily be construed as preferred or advantageous over other embodiments. The detailed description includes specific details for the purpose of providing a thorough understanding of the present invention. However, it will be apparent to those skilled in the art that the present invention may be practiced without these specific details. In some instances, well known structures and devices are shown in block diagram form in order to avoid obscuring the concepts of the present invention.

[0027] Multi-channel communication systems include multiple-input multiple-output (MIMO) communication systems, orthogonal frequency division multiplexing (OFDM) communication systems, MIMO systems that employ OFDM (i.e., MIMO-OFDM systems), and other types of transmissions. For clarity, various aspects and embodiments are described specifically for a MIMO system.

[0028] A MIMO system employs multiple (N_T) transmit antennas and multiple (N_R) receive antennas for data transmission. A MIMO channel formed by the N_T transmit and N_R receive antennas may be decomposed into N_S independent channels, with $N_S \leq \min \{N_T, N_R\}$. Each of the N_S independent channels may also be referred to as a spatial subchannel (or transmission channel) of the MIMO channel. The number of spatial subchannels is determined by the number of eigenmodes for the MIMO channel, which in turn is dependent on a channel response matrix, $\underline{\mathbf{H}}$, that describes the response between the N_T transmit and N_R receive antennas. The elements of the channel response matrix, $\underline{\mathbf{H}}$, are composed of independent Gaussian random variables $\{h_{i,j}\}$, for $i=1, 2, \dots, N_R$ and $j=1, 2, \dots, N_T$, where $h_{i,j}$ is the coupling (i.e., the complex gain) between the j -th transmit antenna and the i -th receive antenna. For simplicity, the channel response matrix, $\underline{\mathbf{H}}$, is assumed to be full-rank (i.e., $N_S = N_T \leq N_R$), and one independent data stream may be transmitted from each of the N_T transmit antennas.

[0029] FIG. 1 is a block diagram of an embodiment of a transmitter system 110 and a receiver system 150 in a MIMO system 100. At transmitter system

110, traffic data for a number of data streams is provided from a data source 112 to a transmit (TX) data processor 114. In an embodiment, each data stream is transmitted over a respective transmit antenna. TX data processor 114 formats, codes, and interleaves the traffic data for each data stream based on a particular coding scheme selected for that data stream to provide coded data.

[0030] The coded data for each data stream may be multiplexed with pilot data using, for example, time division multiplexing (TDM) or code division multiplexing (CDM). The pilot data is typically a known data pattern that is processed in a known manner (if at all), and may be used at the receiver system to estimate the channel response. The multiplexed pilot and coded data for each data stream is then modulated (i.e., symbol mapped) based on a particular modulation scheme (e.g., BPSK, QSPK, M-PSK, or M-QAM) selected for that data stream to provide modulation symbols. The data rate, coding, and modulation for each data stream may be determined by controls provided by a processor 130.

[0031] The modulation symbols for all data streams are then provided to a TX MIMO processor 120, which may further process the modulation symbols (e.g., for OFDM). TX MIMO processor 120 then provides N_T modulation symbol streams to N_T transmitters (TMTR) 122a through 122t. Each transmitter 122 receives and processes a respective symbol stream to provide one or more analog signals, and further conditions (e.g., amplifies, filters, and upconverts) the analog signals to provide a modulated signal suitable for transmission over the MIMO channel. N_T modulated signals from transmitters 122a through 122t are then transmitted from N_T antennas 124a through 124t, respectively.

[0032] At receiver system 150, the transmitted modulated signals are received by N_R antennas 152a through 152r, and the received signal from each antenna 152 is provided to a respective receiver (RCVR) 154. Each receiver 154 conditions (e.g., filters, amplifies, and downconverts) a respective received signal, digitizes the conditioned signal to provide samples, and further processes the samples to provide a corresponding "received" symbol stream.

[0033] An RX MIMO/data processor 160 then receives and processes the N_R received symbol streams from N_R receivers 154 based on a particular receiver processing technique to provide N_T "detected" symbol streams. The

processing by RX MIMO/data processor 160 is described in further detail below. Each detected symbol stream includes symbols that are estimates of the modulation symbols transmitted for the corresponding data stream. RX MIMO/data processor 160 then demodulates, deinterleaves, and decodes each detected symbol stream to recover the traffic data for the data stream. The processing by RX MIMO/data processor 160 is complementary to that performed by TX MIMO processor 120 and TX data processor 114 at transmitter system 110.

[0034] RX MIMO processor 160 may derive an estimate of the channel response between the N_T transmit and N_R receive antennas, e.g., based on the pilot multiplexed with the traffic data. The channel response estimate may be used to perform space or space/time processing at the receiver. RX MIMO processor 160 may further estimate the signal-to-noise-and-interference ratios (SNRs) of the detected symbol streams, and possibly other channel characteristics, and provides these quantities to a processor 170. RX MIMO/data processor 160 or processor 170 may further derive an estimate of the “operating” SNR for the system, which is indicative of the conditions of the communication link. Processor 170 then provides channel state information (CSI), which may comprise various types of information regarding the communication link and/or the received data stream. For example, the CSI may comprise only the operating SNR. The CSI is then processed by a TX data processor 178, modulated by a modulator 180, conditioned by transmitters 154a through 154r, and transmitted back to transmitter system 110.

[0035] At transmitter system 110, the modulated signals from receiver system 150 are received by antennas 124, conditioned by receivers 122, demodulated by a demodulator 140, and processed by a RX data processor 142 to recover the CSI reported by the receiver system. The reported CSI is then provided to processor 130 and used to (1) determine the data rates and coding and modulation schemes to be used for the data streams and (2) generate various controls for TX data processor 114 and TX MIMO processor 120.

[0036] Processors 130 and 170 direct the operation at the transmitter and receiver systems that they are coupled with including the appropriate transmit and receive data processors. Memories 132 and 172 provide storage for program codes and data used by processors 130 and 170, respectively.

[0037] The model for an OFDM MIMO system may be expressed as:

$$\underline{\mathbf{y}} = \underline{\mathbf{H}}\underline{\mathbf{x}} + \underline{\mathbf{n}} \quad , \quad \text{Eq (1)}$$

where $\underline{\mathbf{y}}$ is the received vector, i.e., $\underline{\mathbf{y}} = [y_1 \ y_2 \ \dots \ y_{N_R}]^T$, where $\{y_i\}$ is the entry received on the i -th received antenna and $i \in \{1, \dots, N_R\}$;

$\underline{\mathbf{x}}$ is the transmitted vector, i.e., $\underline{\mathbf{x}} = [x_1 \ x_2 \ \dots \ x_{N_T}]^T$, where $\{x_j\}$ is the entry transmitted from the j -th transmit antenna and $j \in \{1, \dots, N_T\}$;

$\underline{\mathbf{H}}$ is the channel response matrix for the MIMO channel;

$\underline{\mathbf{n}}$ is the additive white Gaussian noise (AWGN) with a mean vector of $\underline{\mathbf{0}}$ and a covariance matrix of $\underline{\mathbf{\Lambda}}_n = \sigma^2 \underline{\mathbf{I}}$, where $\underline{\mathbf{0}}$ is a vector of zeros, $\underline{\mathbf{I}}$ is the identity matrix with ones along the diagonal and zeros everywhere else, and σ^2 is the variance of the noise; and

$[\cdot]^T$ denotes the transpose of $[\cdot]$.

Due to scattering in the propagation environment, the N_T symbol streams transmitted from the N_T transmit antennas interfere with each other at the receiver. In particular, a given symbol stream transmitted from one transmit antenna may be received by all N_R receive antennas at different amplitudes and phases. Each received signal may then include a component of each of the N_T transmitted symbol streams. The N_R received signals would collectively include all N_T transmitted symbols streams. However, these N_T symbol streams are dispersed among the N_R received signals.

[0038] At the receiver, various processing techniques may be used to process the N_R received signals to detect the N_T transmitted symbol streams. These receiver processing techniques may be grouped into two primary categories:

- spatial and space-time receiver processing techniques (which are also referred to as equalization techniques), and

- “successive nulling/equalization and interference cancellation” receiver processing technique (which is also referred to as “successive interference cancellation” or “successive cancellation” receiver processing technique).

[0039] FIG. 2 is a block diagram of a portion of a transmitter unit 200, which may be an embodiment of the transmitter portion of a transmitter system, e.g. such as transmitter system 110 in FIG. 1. In one embodiment, a separate data rate and coding and modulation scheme may be used for each of the N_T data streams to be transmitted on the N_T transmit antennas (i.e., separate coding and modulation on a per-antenna basis). The specific data rate and coding and modulation schemes to be used for each transmit antenna may be determined based on controls provided by processor 130, and the data rates may be determined as described above.

[0040] Transmitter unit 200 includes, in one embodiment, a transmit data processor 202 that receives, codes, and modulates each data stream in accordance with a separate coding and modulation scheme to provide modulation symbols and transmit MIMO. Transmit data processor 202 and transmit data processor 204 are one embodiment of transmit data processor 114 and transmit MIMO processor 120, respectively, of FIG. 1.

[0041] In one embodiment, as shown in FIG. 2, transmit data processor 202 includes demultiplexer 210, N_T encoders 212a through 212t, and N_T channel interleavers 214a through 214t (i.e., one set of demultiplexers, encoders, and channel interleavers for each transmit antenna). Demultiplexer 210 demultiplexes data (i.e., the information bits) into N_T data streams for the N_T transmit antennas to be used for data transmission. The N_T data streams may be associated with different data rates, as determined by rate control functionality, which in one embodiment may be provided by processor 130 or 170 (FIG. 1). Each data stream is provided to a respective encoder 212a through 212t.

[0042] Each encoder 212a through 212t receives and codes a respective data stream based on the specific coding scheme selected for that data stream to provide coded bits. In one embodiment, the coding may be used to increase the reliability of data transmission. The coding scheme may include in one

embodiment any combination of cyclic redundancy check (CRC) coding, convolutional coding, Turbo coding, block coding, or the like. The coded bits from each encoder 212a through 212t are then provided to a respective channel interleaver 214a through 214t, which interleaves the coded bits based on a particular interleaving scheme. The interleaving provides time diversity for the coded bits, permits the data to be transmitted based on an average SNR for the transmission channels used for the data stream, combats fading, and further removes correlation between coded bits used to form each modulation symbol.

[0043] The coded and interleaved bits from each channel interleaver 214a through 214t are provided to a respective symbol mapping block 222a through 222t, of transmit MIMO processor 204, which maps these bits to form modulation symbols.

[0044] The particular modulation scheme to be implemented by each symbol mapping block 222a through 222t is determined by the modulation control provided by processor 130. Each symbol mapping block 222a through 222t groups sets of q_j coded and interleaved bits to form non-binary symbols, and further maps each non-binary symbol to a specific point in a signal constellation corresponding to the selected modulation scheme (e.g., QPSK, M-PSK, M-QAM, or some other modulation scheme). Each mapped signal point corresponds to an M_j -ary modulation symbol, where M_j corresponds to the specific modulation scheme selected for the j -th transmit antenna and $M_j = 2^{q_j}$. Symbol mapping blocks 222a through 222t then provide N_T streams of modulation symbols.

[0045] In the specific embodiment illustrated in FIG. 2, transmit MIMO processor 204 also includes a modulator 224 and inverse Fast Fourier transform (IFFT) block 226a through 226t, along with symbol mapping blocks 222a through 222t. Modulator 224 modulates the samples to form the modulation symbols for the N_T streams on the proper subbands and transmit antennas. In addition modulator 224 provides each of the N_T symbol streams at a proscribed power level. In one embodiment, modulator 224 may modulate symbols according to a hopping sequence controlled by a processor, e.g. processor 130 or 170. In such an embodiment, the frequencies with which the N_T symbol

streams are modulated may vary for each group or block of symbols, frame, or portion of a frame of a transmission cycle.

[0046] Each IFFT block 226a through 226t receives a respective modulation symbol stream from modulator 224. Each IFFT block 226a through 226t groups sets of N_F modulation symbols to form corresponding modulation symbol vectors, and converts each modulation symbol vector into its time-domain representation (which is referred to as an OFDM symbol) using the inverse fast Fourier transform. IFFT blocks 226a through 226t may be designed to perform the inverse transform on any number of frequency subchannels (e.g., 8, 16, 32, ..., N_F).

[0047] Each time-domain representation of the modulation symbol vector generated by IFFT blocks 226a through 226t is provided to an associated cyclic prefix generator 228a through 228t. The cyclic prefix generators 228a through 228t pre-pending a prefix of a fixed number of samples, which are generally a number of samples from the end of the OFDM symbol, to the N_S samples that constitute an OFDM symbol to form a corresponding transmission symbol. The prefix is designed to improve performance against deleterious path effects such as channel dispersion caused by frequency selective fading. Cyclic prefix generators 228a through 228t then provide a stream of transmission symbols to an associated delay element 230a through 230t-1.

[0048] Each delay element 230a through 230t-1 provides a delay to each symbol that is output from cyclic prefix generators 228a through 228t. In one embodiment, the delay provided by each delay element 230a through 230t-1 varies in time. In one embodiment, this delay is such that the delay varies between consecutive symbols output by the cyclic prefix generator or consecutive symbols that are to be consecutively transmitted from the transmitter unit 200. In other embodiments, the delay may vary between groups of two, three, four, or more symbols with each symbol within the group having a same delay. In additional embodiments, all of the symbols in a frame or burst period would have a same delay with each frame or burst period having a different delay for each symbol than a preceding or following frame or burst period.

[0049] Also, in the embodiment depicted in Fig. 2, the delay provided by each delay element 230a through 230t-1 is different than the delay provided by

each other delay element. Further, while Fig. 2 depicts that cyclic prefix generator 228a is not coupled to a delay element, other embodiments may provide a delay element to the output of each of the cyclic prefix generators 228a through 228t.

[0050] The symbols output by delay elements 230a through 230t-1 are provided to an associated transmitter 232a through 232t which causes the symbols to be transmitted by antennas 232a through 232t according to the delay provided by delay elements 230a through 230t-1.

[0051] As stated above, in one embodiment, the time varying delay Δ_m provided by each delay element 230a through 230t- varies with time. In one embodiment, the i -th OFDM symbol is transmitted as a transmitted symbol from antenna m according a delay of Eq. 2:

$$s((k - \Delta_m) \bmod N) = \frac{1}{\sqrt{N}} \sum_{n=0}^{N-1} X_n e^{-j(2\pi/N)n\Delta_m(i)} \cdot e^{-j(2\pi/N)nk} \quad (\text{Eq. 2})$$

The resulting overall channel in this case may be described as

$$H(i, n) = \sum_{m=1}^M H_m(i, n) \cdot e^{-j(2\pi/N)n\Delta_m(i)} \quad (\text{Eq. 3})$$

where $H_m(i, n)$ is the channel n -th discrete Fourier Transform (DFT) coefficient for the channel impulse response from the m -th transmitting antenna to the receiving antenna.

[0052] The use of this time varying delay can introduce both frequency selectivity and time selectivity into the channel that may be utilized to improve performance. For example, by using time varying delays for transmission symbols across different sub-carriers and different OFDM symbols, both the time selectivity and frequency selectivity can simultaneously be provided. Moreover, in the case of transmission to multiple users, the time variation of the channel that is provided by varying the delay for symbols can be exploited to provide diversity gains to each of the multiple users, since each user's receiver will have different channel conditions than each other user's receiver.

[0053] In one embodiment, the delay $\Delta_m(i)$ may be changed in a linear fashion with time with each consecutive, or group of consecutive symbols, being delayed by $n \cdot \beta$ samples, where β is a constant and n varying from $0, 1, \dots, N-1$, where N is the number of symbols in a frame, burst period, or symbol stream.

In another embodiment, the delay $\Delta_m(i)$ may be a random delay, based upon a pseudo random sequence, with respect to an adjacent channel, i.e. antenna, of the N_T antennas, a preceding and/or following symbol. In an additional embodiment, the delay may be varied by $f(x)$ where f is a function such as a sine, cosine, or other time varying function, and x varies from $0, 1, \dots, N-1$ or some multiples thereof, where N is the number of symbols in a frame, burst period, or symbol stream. In each of the previous embodiments, the delay may also be changed based on feedback information, in which case the receiver sends back a channel quality indicator that describes the overall channel conditions and $\Delta_m(i)$ is changed to improve the overall quality.

[0054] Referring to Fig. 3, an embodiment of a time varying delay applied to symbols transmitted from a same antenna is illustrated. Symbols S_1 , S_2 , S_3 , and S_4 are generated to be transmitted during consecutive time slots T_1 , T_2 , T_3 , and T_4 respectively. Each symbol S_1 , S_2 , S_3 , and S_4 comprises nine samples N_{S1} , N_{S2} , N_{S3} , N_{S4} , N_{S5} , N_{S6} , N_{S7} , N_{S8} , N_{S9} , and a two-sample cyclic prefix N_{C1} and N_{C2} , which are samples N_{S8} , and N_{S9} respectively. It should be noted that the content of each sample may be different for each of the symbols. It should be noted that the samples N_{S1} , N_{S2} , N_{S3} , N_{S4} , N_{S5} , N_{S6} , N_{S7} , N_{S8} , N_{S9} are to be combined to form symbol S_1 in the order of N_{S1} , N_{S2} , N_{S3} , N_{S4} , N_{S5} , N_{S6} , N_{S7} , N_{S8} , N_{S9} .

[0055] The delay element, e.g. delay element 230a, then provides a delay to the symbol S_1 , S_2 , S_3 , and S_4 that are transmitted from the same antenna. In the embodiment depicted in Fig. 3, the delay for symbol S_1 is one sample period t_1 . The next symbol S_2 , which is to be transmitted on the same antenna immediately after symbol S_1 , is delayed by two sample periods t_1 and t_2 . The next symbol S_3 , which is to be transmitted on the same antenna immediately after symbol S_2 , is delayed by three sample periods t_1 , t_2 , and t_3 . The next symbol S_4 , which is to be transmitted on the same antenna immediately after symbol S_3 , is delayed by four sample periods t_1 , t_2 , t_3 , and t_4 . If additional symbols are to be transmitted on the same antenna, the next consecutive symbol would be transmitted with a delay of five sample periods t_1 , t_2 , t_3 , t_4 , and t_5 . In this way, a linear time varying delay may be applied to transmission from an antenna, which may or may not be part of a MIMO system.

[0056] It should be noted the linear variation of the delay period need not be sequential by one sample period, but may be sequential by 2 or more sample periods as well, e.g. the first symbol S_1 may be delayed by three sample periods, the second symbol S_2 is delayed by six sample periods, the third symbol S_3 is delayed by nine sample periods, and the fourth symbol S_4 is delayed by twelve sample periods. Also, the linear variation need not vary between each consecutive symbol but for groups of symbols, e.g. symbols S_1 and S_2 are each delayed by one sample period and symbols S_3 , and S_4 are each delayed by two or more sample periods.

[0057] Referring to Fig. 4, an embodiment of a time varying delay applied to a symbol transmitted on multiple antennas is illustrated. A same symbol S_1 is to be transmitted from antennas A_1 , A_2 , A_3 , and A_4 . Symbol S_1 comprises nine samples N_{S1} , N_{S2} , N_{S3} , N_{S4} , N_{S5} , N_{S6} , N_{S7} , N_{S8} , N_{S9} , and a two-sample cyclic prefix N_{C1} and N_{C2} , which are samples N_S , and N_{S9} respectively. From first antenna A_1 symbol S_1 is not delayed by any sample periods. From second antenna A_2 , symbol S_1 is delayed by one sample period t_1 . From third antenna A_3 , symbol S_1 is delayed by two sample periods t_1 and t_2 . From fourth antenna A_4 , symbol S_1 is delayed by three sample periods t_1 , t_2 , and t_3 . As such, time and frequency diversity may be provided in a MIMO system in addition to the spatial diversity provided by antennas A_1 , A_2 , A_3 , and A_4 .

[0058] The time diversity provided for the scheme depicted in Fig. 4, and variations thereof, provides a reduction in the likelihood of collisions by the same samples of a same symbol thereby minimizing the possibility of destructive or constructive addition of the channels.

[0059] It should be noted that the delay variation between a same symbol transmitted on a same antenna need not be linear or even related to the delay on the other antennas, so long as if the symbol is to be transmitted substantially simultaneously, it should be delayed by a different amount on each antenna.

[0060] It should be noted that, the order utilized need not correspond to the number of antennas and may vary for smaller groups or in a larger number than the number of antennas.

[0061] In addition, as discussed with respect to Fig. 2, the delay may be random and may be based on a function such as a sine, cosine, or other function. In some embodiments, the delay period is limited to a number of

74769-1518

15

samples in a symbol, where the delay period may be repeated after a fixed or random number of symbols. Also, it should be noted that the delay between symbols can be fractions of sample periods and is not limited to being multiples of entire sample periods. The fractional delay may be implemented, in one embodiment, by using fractions of clock periods of the one or more clocks of transmitter unit 200.

[0062] Referring to Fig. 5, a block diagram of another embodiment of a transmitter unit that provides time-varying delay diversity is illustrated. Transmitter unit 500 is substantially identical to transmitter unit 200. In addition, scaling circuits 554a through 554t-1 are each coupled to an output of one of the delay elements 530a through 530t-1. Scaling circuits 534a through 534t-1 provide a fixed scalar shift to the delay provided by each of the delay elements 530a through 530t-1. For example, a fixed shift is applied to each delay so that, for example if a constant shift of 0.5 is applied then a one sample period delay would be 0.5 samples periods, a two-sample period delay would be one sample period, and a five sample period delay would be two and a half sample periods. In one embodiment, each of scaling circuits 554a through 554t-1 provides a shift that is different than each other scaling circuit. In one embodiment, a linear progression is provided across scaling circuits 554a through 534t-1 that is scaling circuit 554a provides a shift less than, 554b, which is less than 554c, etc.

[0063] It should be noted that while Fig. 5, depicts that cyclic prefix generator 528a is not coupled to a delay element, other embodiments may provide a delay element to the output of each of the cyclic prefix generators 528a through 528t. Also, while Fig. 5, depicts that cyclic prefix generator 528a is not coupled to a scaling circuit, other embodiments may provide a scaling circuit to the output of each of the cyclic prefix generators 528a through 528t, regardless of whether a delay circuit is coupled to the cyclic prefix generator.

[0064] Referring to Fig. 6, a block diagram of an embodiment of a receiver unit capable of utilizing time-varying delay diversity is illustrated. The transmitted signals are received by antennas 602a through 602r and processed by receivers 604a through 604r, respectively, to provide N_R sample streams, which are then provided to an RX processor 606.

[0065] Within demodulator 608, cyclic prefix removal element 612a through 612r and FFT blocks 614a through 614r provide N_R symbol streams. Cyclic prefix removal elements 612a through 612r remove the cyclic prefix included in each transmission symbol to provide a corresponding recovered OFDM symbol.

[0066] FFT blocks 614a through 614r then transform each recovered symbol of the symbol stream using the fast Fourier transform to provide a vector of N_F recovered modulation symbols for the N_F frequency subchannels for each transmission symbol period. FFT blocks 614a through 614r provide N_R received symbol streams to a spatial processor 620.

[0067] Spatial processor 620 performs spatial or space-time processing on the N_R received symbol streams to provide N_T detected symbol streams, which are estimates of the N_T transmitted symbol streams. Spatial processor 620 may implement a linear ZF equalizer, a channel correlation matrix inversion (CCMI) equalizer, a minimum mean square error (MMSE) equalizer, an MMSE linear equalizer (MMSE-LE), a decision feedback equalizer (DFE), or some other equalizer, which are described and depicted in U.S. Patent Application Publication Nos. 2003/0125040, 2003/0035491, 2002/0191703 and 2003/0003880.

[0068] Spatial processor 620 may be capable of compensating for the time varying delay provided by the delay elements and/or scaling circuit of the transmitters, which are discussed with respect to Figs. 2 and 5. This compensation may be provided, in one embodiment, by having the delay scheme, e.g. linear, random according to a pseudo random sequence, or function, known *a priori* by the receiver unit 600. This knowledge may be provide, for example, by having a same scheme utilized by all transmitters or providing information as to the scheme utilized as part of the initialization of communication between the transmitter and receiver unit 600.

[0069] A multiplexer/demultiplexer 622 then multiplexes/demultiplexes the detected symbols, and provides N_D aggregated detected symbol streams for the N_D data streams to N_D symbol demapping elements 624a through 624r. Each symbol demapping element 624a through 624r then demodulates the detected symbols in accordance with a demodulation scheme that is complementary to the modulation scheme used for the data stream. The N_D demodulated data

streams from N_D symbol demapping elements 624a through 624r are then provided to a RX data processor 610.

[0070] Within RX data processor 610, each demodulated data stream is de-interleaved by a channel de-interleaver 632a through 632r in a manner complementary to that performed at the transmitter system for the data stream, and the de-interleaved data is further decoded by a decoder 634a through 634r in a manner complementary to that performed at the transmitter system. For example, a Turbo decoder or a Viterbi decoder may be used for decoder 634a through 634r if Turbo or convolutional coding, respectively, is performed at the transmitter unit. The decoded data stream from each decoder 634a through 634r represents an estimate of the transmitted data stream. Decoders 634a through 634r may also provide the status of each received packet (e.g., indicating whether it was received correctly or in error). Decoder 634a through 634r may further store demodulated data for packets not decoded correctly, so that this data may be combined with data from a subsequent incremental transmission and decoded.

[0071] In the embodiment shown in FIG. 6, a channel estimator 640 estimates the channel response and the noise variance and provides these estimates to processor 650. The channel response and noise variance may be estimated based on the detected symbols for the pilot.

[0072] Processor 650 may be designed to perform various functions related to rate selection. For example, processor 650 may determine the maximum data rate that may be used for each data stream based on the channel estimates and other parameters such as the modulation scheme.

[0073] Referring to Fig. 7, a block diagram of an embodiment of a delay element is illustrated. A processor 700 is coupled via a bus 702 with a memory 704. Memory 704 is utilized to store samples of time-domain representations of the modulation symbols that are provided for transmission. The samples of each symbol are stored in memory locations that are known to processor 700. Processor 700 can then instruct memory 704 to output the samples of each symbol utilizing any desired time varying delay for consecutive, groups, or frames or burst periods of symbols.

[0074] As described with respect to Figs. 3 and 4, the delay for each symbol may vary between each symbol, for groups of symbols that are to be

transmitted contiguously, and between symbols in different frames or bursts periods. The use of a memory allows for any predetermined or adaptive scheme to be utilized for delaying provision of the symbols and therefore providing time diversity that may be varied based upon channel conditions as well as pre-determined schemes, e.g. a linear variation.

[0075] Referring to Fig. 8, a flow chart of an embodiment of a method for providing time-varying delay diversity is illustrated. Samples of that represent one or more modulated symbols after being subject to an inverse Fast Fourier transform are provided, block 800. A cyclic prefix is then pre-pended to each of the modulated symbols, block 802. The size of the prefix may vary as desired, and in one embodiment may be thirty-two or more samples.

[0076] The samples including the cyclic prefix are then stored in a memory, block 804, which in one embodiment may be a buffer. In one embodiment, the samples for each modulated symbol are stored in memory according to the order in which they are provided after pre-pending of the cyclic prefix. In other embodiments, the samples of each modulated symbol may be stored in any order that is desired. A first symbol to be transmitted for a symbol is removed according to a first delay N , block 806. The next symbol to be transmitted is then removed according a second delay, which is different than the first delay, block 808. The second delay, and additional delays for later symbols, may be delays of $N+\beta$, where β may be a linear increase or decrease from N , a random change from N , or be the result of some function.

[0077] A determination is then made as to whether of the symbols that need to be delayed have been transmitted or otherwise utilized, block 810. If not, additional delays are provided to the output of further symbols from the memory or buffer according to the same time variance, block 808. If yes, then the process ceases, and additional symbols are provided as discussed with respect blocks 800-804, block 812.

[0078] Referring to Fig. 9, a block diagram of a further embodiment of a transmitter unit that provides time-varying delay diversity is illustrated. Transmitter unit 900 is substantially identical to transmitter unit 200. However, instead of utilizing delay element 230a through 230t-1 coupled to an output of IFFT blocks 226a through 226t, phase shift circuits 930a through 930t-1 are coupled before an input of IFFT blocks 926a through 926t, in they receive the

output of modulator 924. Phase shift circuits 930a through 930t provide a time-varying phase shift to the samples of each symbol. For example, phase shift circuit 930a may provide a phase shift Φ_1 to the samples of a first symbol and a phase shift Φ_1 to the samples of a next or later symbol output by the modulator. The samples of a later symbol may have a phase shift of a different or same amount. This phase shift, may operate as a delay in the time domain, after application of the IFFT by IFFT blocks 926a through 926t.

[0079] Each phase shift circuit 930a through 930t may provide a different phase shift than each other phase shift circuit 930a through 930t, so that a delay of a same symbol transmitted from multiple antennas is different from each antenna. The variance may or may not be a function of the phase shift applied with respect to any other antenna.

[0080] In one embodiment, the phase shift provided by each phase shift circuit 930a through 930t is such that the phase shift varies between consecutive symbols output by the modulator. In other embodiments, the phase shift may vary between groups of two, three, four, or more symbols with each symbol within the group having a same phase shift. In additional embodiments, all of the symbols in a frame or burst period would have a same phase shift with each frame or burst period having a different phase shift for each symbol than a preceding or following frame or burst period.

[0081] It should be noted that while Fig. 9, depicts that a phase shift circuit is not coupled to cyclic prefix generator 928a, other embodiments may provide a phase shift circuit to the output of each of the cyclic prefix generators 928a through 928t.

[0082] In some embodiment, the modulator and the phase shift circuit may comprise a processor.

[0083] Referring to Fig. 10, a flow chart of an embodiment of a method for providing time-varying delay diversity is illustrated. Samples of a first symbol output by a modulator is subject to a first phase shift Φ_1 , block 1000. The samples of a second symbol are then subject to a phase shift Φ_2 , which is different than Φ_1 , block 1002. A determination is then made whether additional symbols have yet to be phase shifted, block 1004. If not, then a phase shift which may be the same or different as Φ_1 or Φ_2 is then applied to the samples

of a next symbol output by the modulator, block 106. This process is then repeated, until there are no additional symbols to phase shift.

[0084] If there are no additional symbols to phase shift, the symbols are subject to IFFT, block 1008, the pre-pending of a cyclic prefix, block 1010, and stores the symbol in memory, block 1012, which in one embodiment may be a buffer. In one embodiment, the samples for each modulated symbol are stored in memory according to the order in which they are provided after pre-pending of the cyclic prefix. In other embodiments, the samples of each modulated symbol may be stored in any order that is desired.

[0085] In some embodiments, the phase shift may be different between consecutive symbols, groups of symbols, or frames by a phase that is equal to a constant angle multiplied by a varying number corresponding to the location of the symbol in a symbol stream or other ordinal number. The constant angle may be fixed or may vary according to other time constants. Also, the constant angle applied to symbols intended for different antennas may be different.

[0086] In other embodiments, the phase shift may vary according to a random phase with respect to any other symbols. This may be provided by utilizing a pseudo random code to generate the phase shift.

[0087] It should be noted that while FIG. 10 illustrates waiting to perform IFFT and cyclic prefix pre-pending until a phase shift is applied to all of the symbols of a frame or burst period, each symbol may be subject to IFFT and cyclic prefix pre-pending either individually or in groups before completion of phase shifts to each of the symbols of a frame or burst period.

[0088] It should be noted that transmitter 200 and 500 may receive and process a respective modulation symbol stream (for MIMO without OFDM) or transmission symbol stream (for MIMO with OFDM) to generate a modulated signal, which is then transmitted from the associated antenna. Other designs for the transmitter unit may also be implemented and are within the scope of the invention.

[0089] The coding and modulation for MIMO systems with and without OFDM are described in further detail in the following U.S. patent applications:

74769-1518

21

- U.S. Patent Application Publication No. 2003/0125040, entitled "Multiple-Access Multiple-Input Multiple-Output (MIMO) Communication System," filed November 6, 2001;
- U.S. Patent Application Publication No. 2003/0035491, entitled "Method and Apparatus for Processing Data in a Multiple-Input Multiple-Output (MIMO) Communication System Utilizing Channel State Information," filed May 11, 2001;
- U.S. Patent Application Publication Nos. 2002/0191703 and 2003/0003880, both entitled "Method and Apparatus for Utilizing Channel State Information in a Wireless Communication System," respectively filed March 23, 2001 and September 18, 2001;
- U.S. Patent Application Publication No. 2003/0043928, entitled "Coding Scheme for a Wireless Communication System," filed February 1, 2001; and
- U.S. Patent Application Publication No. 2002/0154705, entitled "High Efficiency, High Performance Communications System Employing Multi-Carrier Modulation," filed March 30, 2000.

These applications are all assigned to the assignee of the present application and incorporated herein by reference. Application Publication No. 2003/043928 describes a coding scheme whereby different rates may be achieved by coding the data with the same base code (e.g., a convolutional or Turbo code) and adjusting the puncturing to achieve the desired rate. Other coding and modulation schemes may also be used, and this is within the scope of the invention.

[0090] Those skilled in the art will appreciate that the various illustrative logical blocks, modules, circuits, and algorithms described in connection with the embodiments disclosed herein may be implemented as electronic hardware, computer software, or combinations of both. To clearly illustrate this interchangeability of hardware and software, various illustrative components, blocks, modules, circuits, and algorithms have been described above generally in terms of their functionality. Whether such functionality is implemented as hardware or software depends upon the particular application and design constraints imposed on the overall system. Skilled artisans may implement the

described functionality in varying ways for each particular application, but such implementation decisions should not be interpreted as causing a departure from the scope of the present invention.

[0091] The various illustrative logical blocks, processors, modules, and circuits described in connection with the embodiments disclosed herein may be implemented or performed with a general purpose processor, a digital signal processor (DSP), circuits, an application specific integrated circuit (ASIC), a field programmable gate array (FPGA) or other programmable logic device, discrete gate or transistor logic, discrete hardware components, or any combination thereof designed to perform the functions described herein. A general purpose processor may be a microprocessor, but in the alternative, the processor may be any conventional processor, processor, microprocessor, or state machine. A processor may also be implemented as a combination of devices, e.g., a combination of a DSP and a microprocessor, a plurality of microprocessors, one or more microprocessors in conjunction with a DSP core, multiple logic elements, multiple circuits, or any other such configuration.

[0092] The methods or algorithms described in connection with the embodiments disclosed herein may be embodied directly in hardware, in a software module executed by a processor, or in a combination of the two. A software module may reside in RAM memory, flash memory, ROM memory, EPROM memory, EEPROM memory, registers, hard disk, a removable disk, a CD-ROM, or any other form of storage medium known in the art. An exemplary storage medium is coupled to the processor such the processor can read information from, and write information to, the storage medium. In the alternative, the storage medium may be integral to the processor. The processor and the storage medium may reside in an ASIC. The ASIC may reside in a user terminal. In the alternative, the processor and the storage medium may reside as discrete components in a user terminal.

[0093] The previous description of the disclosed embodiments is provided to enable any person skilled in the art to make or use the present invention. Various modifications to these embodiments will be readily apparent to those skilled in the art, and the generic principles defined herein may be applied to other embodiments without departing from the spirit or scope of the invention. Thus, the present invention is not intended to be limited to the embodiments

shown herein but is to be accorded the widest scope consistent with the principles and novel features disclosed herein.

WHAT IS CLAIMED IS:

74769-1518

24

CLAIMS:

1. A method for providing transmission diversity in a multi-channel communication system comprising:
 - providing to a first antenna a first symbol comprising a first plurality
5 of samples;
 - providing to a second antenna the first symbol after a first delay period;
 - providing to the first antenna a second symbol comprising a second plurality of samples;
 - 10 providing to the second antenna the second symbol after a second delay period that is different than the first delay period;
 - providing to the first antenna a third symbol comprising a third plurality of samples;
 - providing to the second antenna the third symbol after a third delay
15 period that is different than the first delay period and the second delay period, wherein
 - the first delay period comprises a delay of X sample periods, the second delay period comprises a delay of Y sample periods which is any number of sample periods other than X , and the third delay period comprises a delay of Z
20 sample periods which is any number of sample periods other than X or Y , and
 - wherein the first delay period, the second delay period, and the third delay period are independent of feedback information on channel conditions.
2. The method of claim 1, wherein the first symbol, second symbol, and third symbol are consecutive symbols of a same symbol stream.
- 25 3. The method of claim 1, wherein the third symbol is transmitted immediately after the second symbol that is transmitted immediately after the first symbol.

74769-1518

25

4. The method of claim 1, wherein the first symbol, second symbol, and third symbol are non-consecutive symbols of a same symbol stream.

5. The method of claim 4, wherein the first symbol and second symbol are separated by a number of symbols and the second symbol and the third symbol are separated by the number of symbols.

6. The method of claim 1, wherein the first symbol, second symbol, and third symbol are each transmitted in different frames.

7. The method of claim 1, wherein

providing the first symbol after the first delay period comprises

10 applying a first phase shift to each of the first plurality of samples;

providing the second symbol after the second delay period that is different than the first delay period comprises applying a second phase shift to the second plurality of samples, that is different than the first phase shift; and

providing the third symbol after a third delay period that is different

15 than the first delay period and the second delay period comprises applying a third phase shift to the third plurality of samples that is different than the first phase shift and the second phase shift.

8. The method of claim 1, wherein the first delay period comprises a delay of X sample periods, the second delay period comprises a delay of $X+\beta$ sample periods, and the third delay period comprises a delay of $X+2\beta$ sample periods, wherein β is a constant.

9. The method of claim 1, further comprising

appending prior to providing, a cyclic prefix to the first symbol;

appending prior to providing, a cyclic prefix to the second symbol;

25 and

appending prior to providing, a cyclic prefix to the third symbol.

74769-1518

26

10. An apparatus for providing transmission diversity in a multi-channel communication system comprising:

at least two antennas;

a modulator coupled with the at least two antennas; and

5 means for providing delay coupled between the modulator and one of the at least two antennas, the means for providing delay configured to delay symbols output from the modulator to the antenna by a delay period,

wherein the means for providing delay provides the delay period so that it is different between consecutive symbols by a number of sample periods
10 that is equal to a constant multiplied by a varying number corresponding to the location of the symbol, and

wherein the first delay period, the second delay period, and the third delay period are independent of feedback information on channel conditions.

11. The apparatus of claim 10, wherein the modulator utilizes different
15 carrier frequencies of a frequency band to modulate symbols.

12. The apparatus of claim 10, wherein the modulator and the means for providing delay comprises a processor.

13. The apparatus of claim 10, wherein the at least two antennas
comprise at least three antennas, the means for providing delay being coupled
20 between the modulator and another of the at least three antennas and further configured to provide another delay period that varies with time.

14. The apparatus of claim 13, wherein the delay period is different
between consecutive symbols output by the modulator to the antenna and the
another delay period is different between consecutive symbols output by the
25 modulator to the another antenna.

15. The apparatus of claim 10, further comprising means for generating a cyclic prefix for each modulated symbol.

74769-1518

27

16. The apparatus of claim 10,

wherein the means for providing delay is further configured to vary the delay between consecutive symbols output by the modulator.

17. The apparatus of claim 16, wherein the means for providing delay
5 further comprises means for providing a delay between consecutive symbols that varies by $n \cdot \beta$ samples, where n is an ordinal location of the symbol in a symbol stream and β is a constant.

18. The apparatus of claim 16, wherein the means for providing delay
10 further comprises means for providing a delay between consecutive symbols that varies by a random number of sample periods.

19. A computer-readable medium having computer-executable instructions stored thereon that, when executed by a computer, cause the computer to perform the method of any one of claims 1-9.

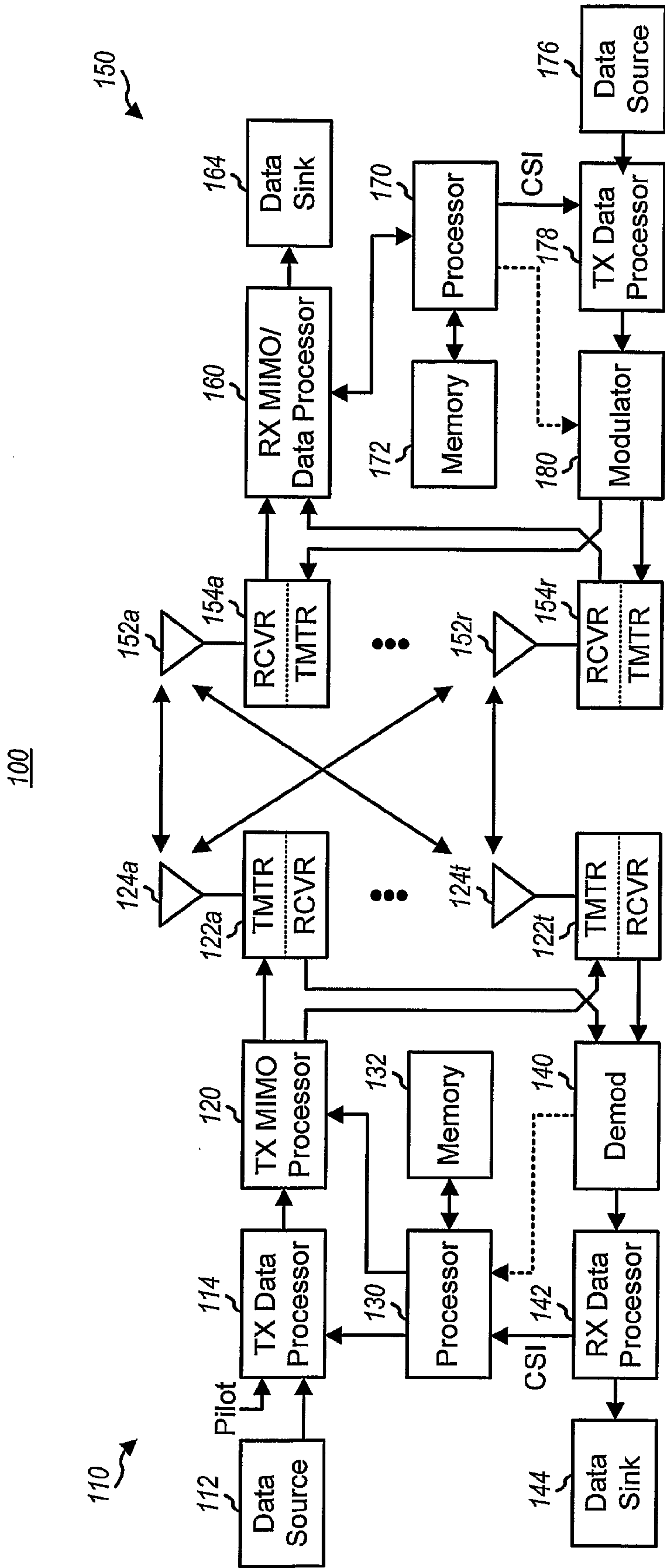

FIG. 1

2/10

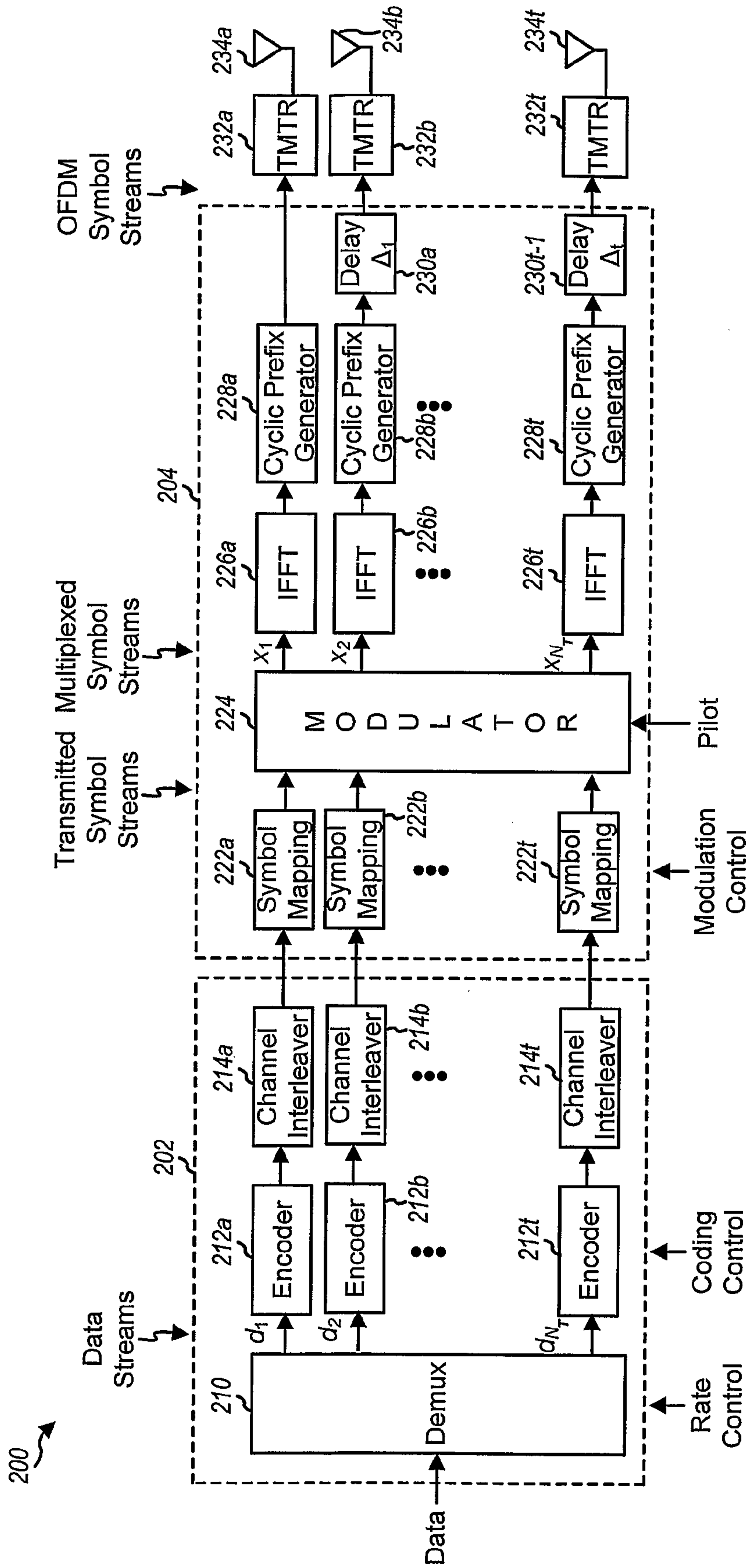

FIG. 2

3/10

FIG. 3

	t_1	t_2	t_3	t_4	t_5	t_6	t_7	t_8	t_9	t_{10}	t_{11}	t_{12}	t_{13}	t_{14}	t_{15}
S_1		N_{c1}	N_{c2}	N_{s1}	N_{s2}	N_{s3}	N_{s4}	N_{s5}	N_{s6}	N_{s7}	N_{s8}	N_{s9}			
S_2			N_{c1}	N_{c2}	N_{s1}	N_{s2}	N_{s3}	N_{s4}	N_{s5}	N_{s6}	N_{s7}	N_{s8}	N_{s9}		
S_3				N_{c1}	N_{c2}	N_{s1}	N_{s2}	N_{s3}	N_{s4}	N_{s5}	N_{s6}	N_{s7}	N_{s8}	N_{s9}	
S_4					N_{c1}	N_{c2}	N_{s1}	N_{s2}	N_{s3}	N_{s4}	N_{s5}	N_{s6}	N_{s7}	N_{s8}	N_{s9}

T_1

T_2

T_3

T_4

FIG. 4

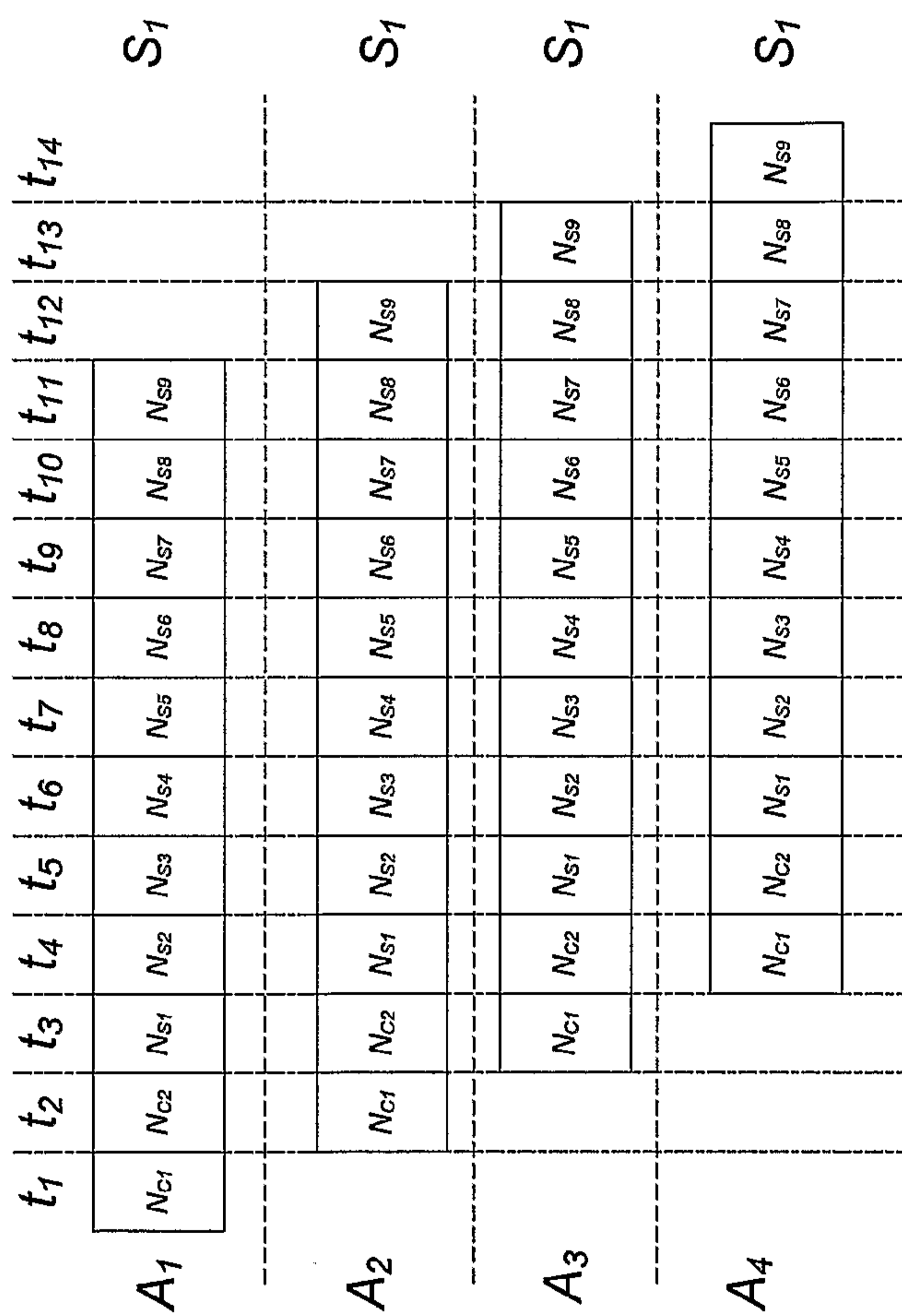

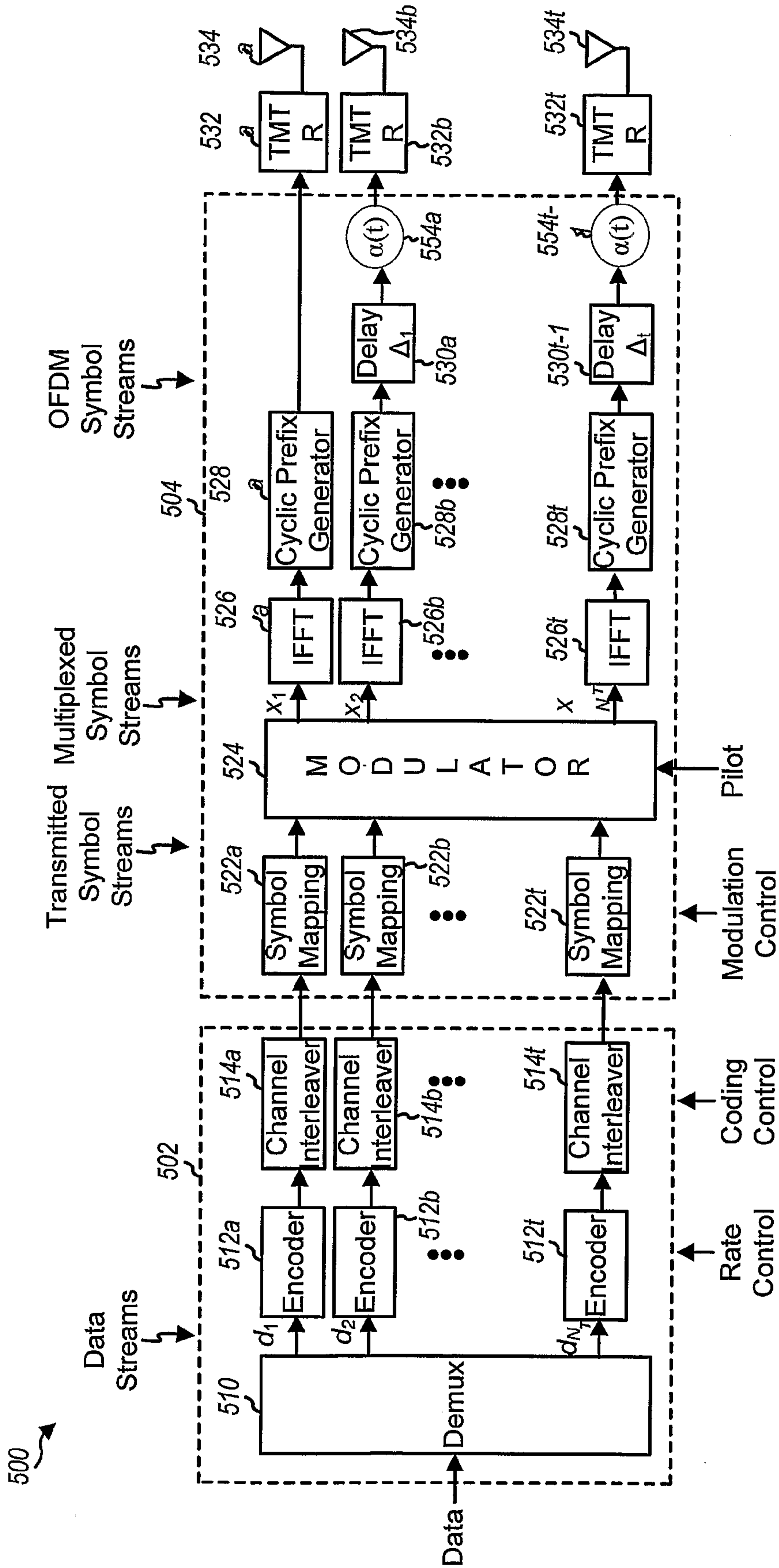

FIG. 5

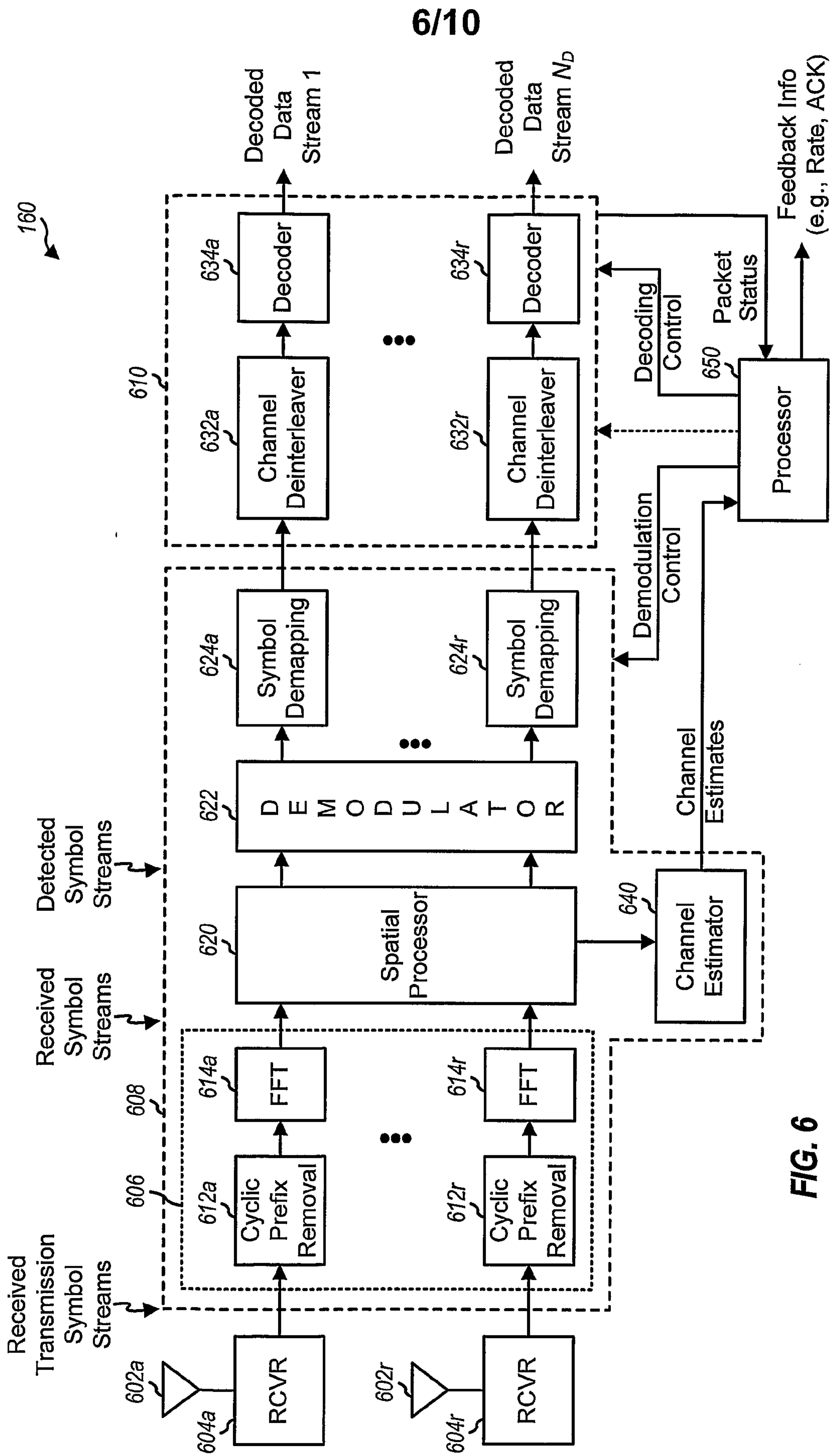

FIG. 6

7/10

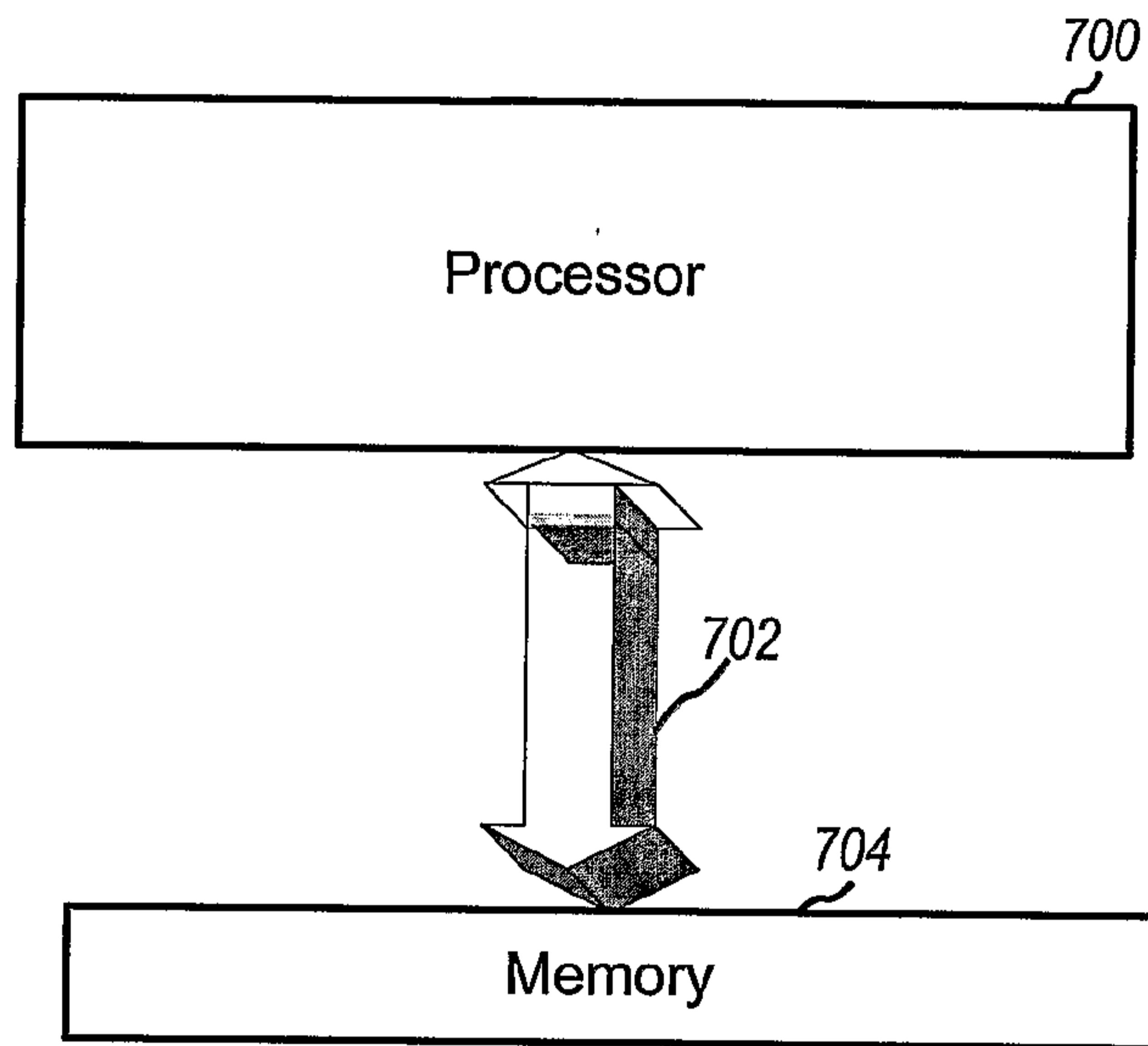
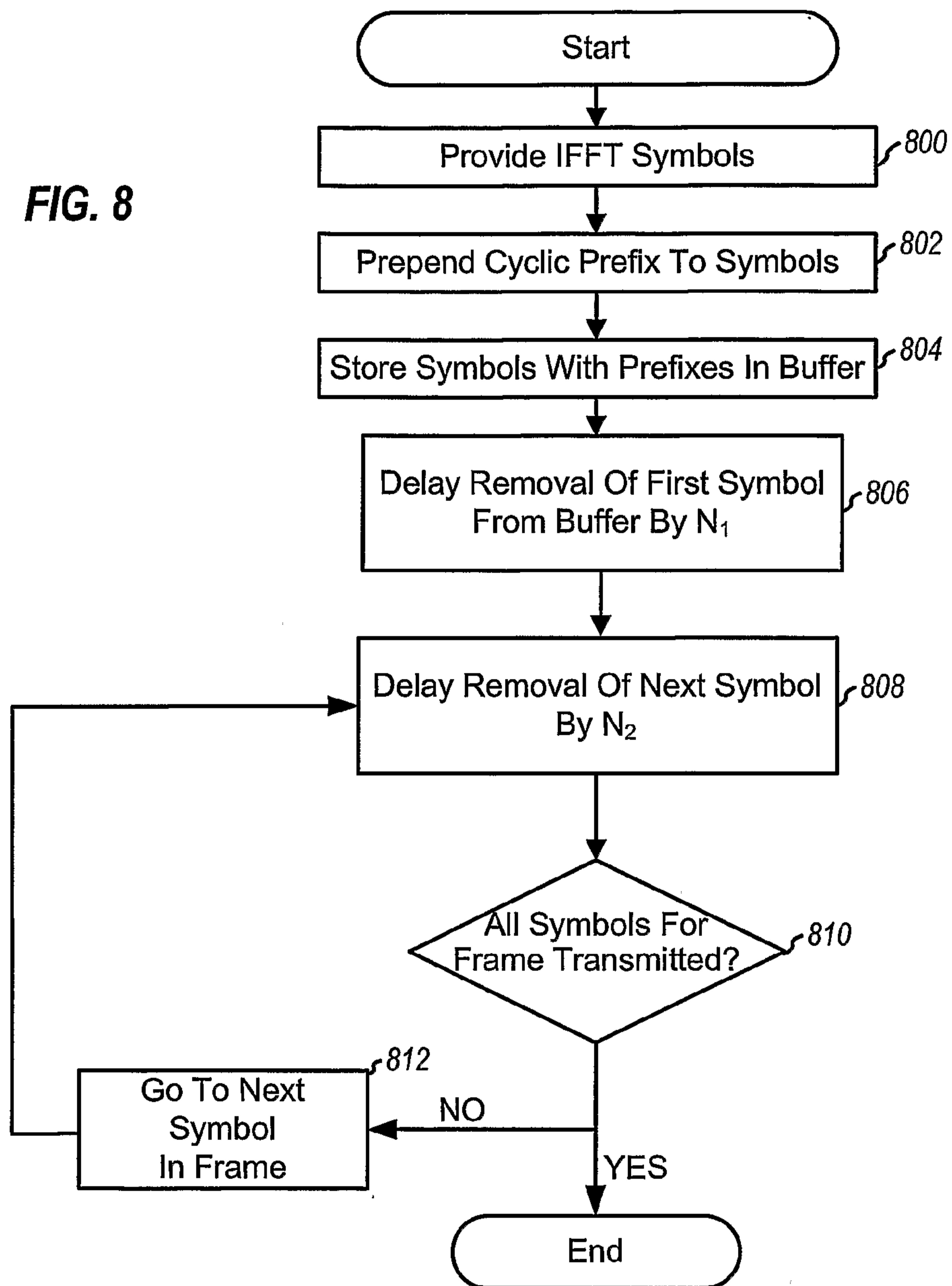

FIG. 7

8/10

FIG. 8



9/10

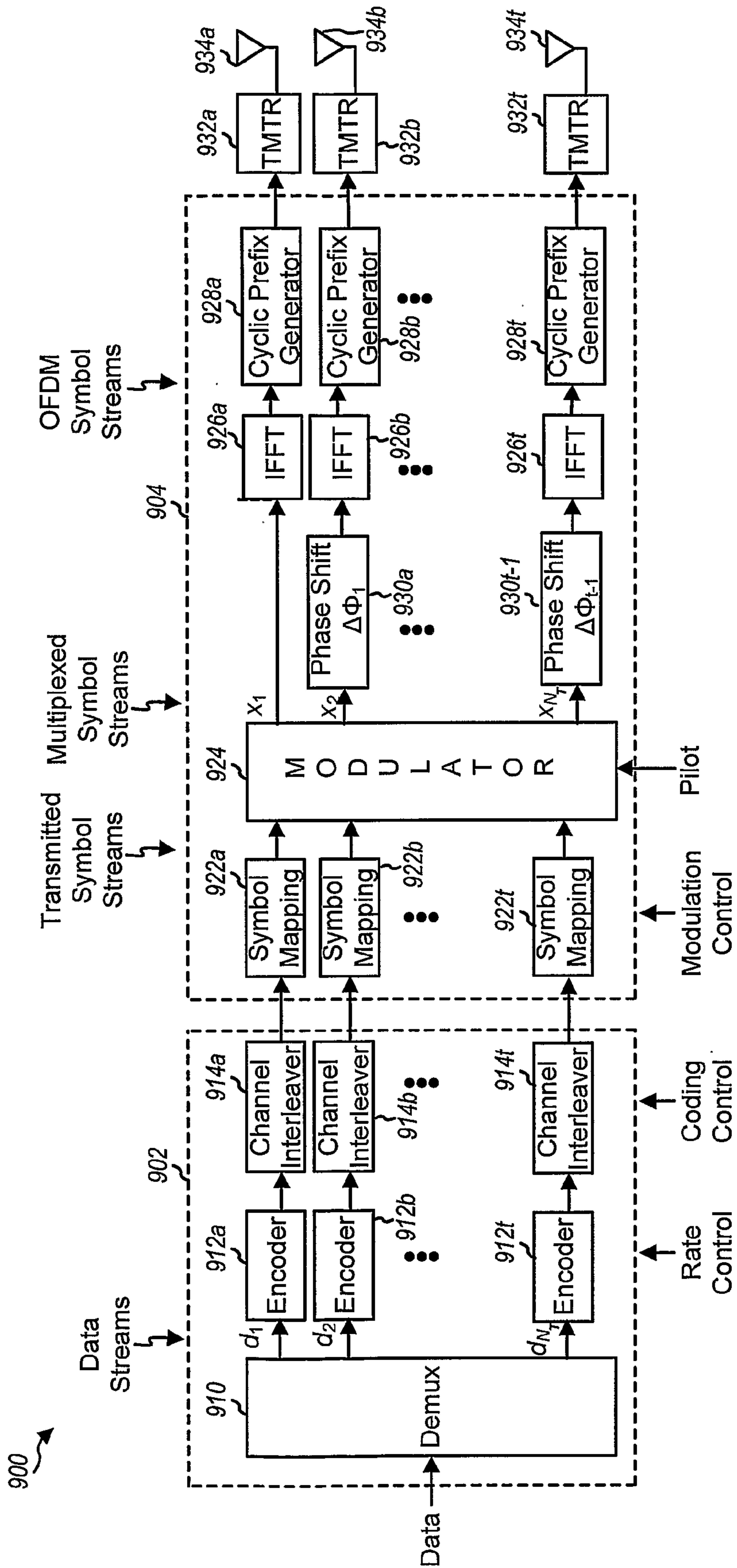

FIG. 9

10/10

