

H. Haupt,
Rotary Steam Valve.

N^o 13,910.

Patented Aug. 23, 1864.

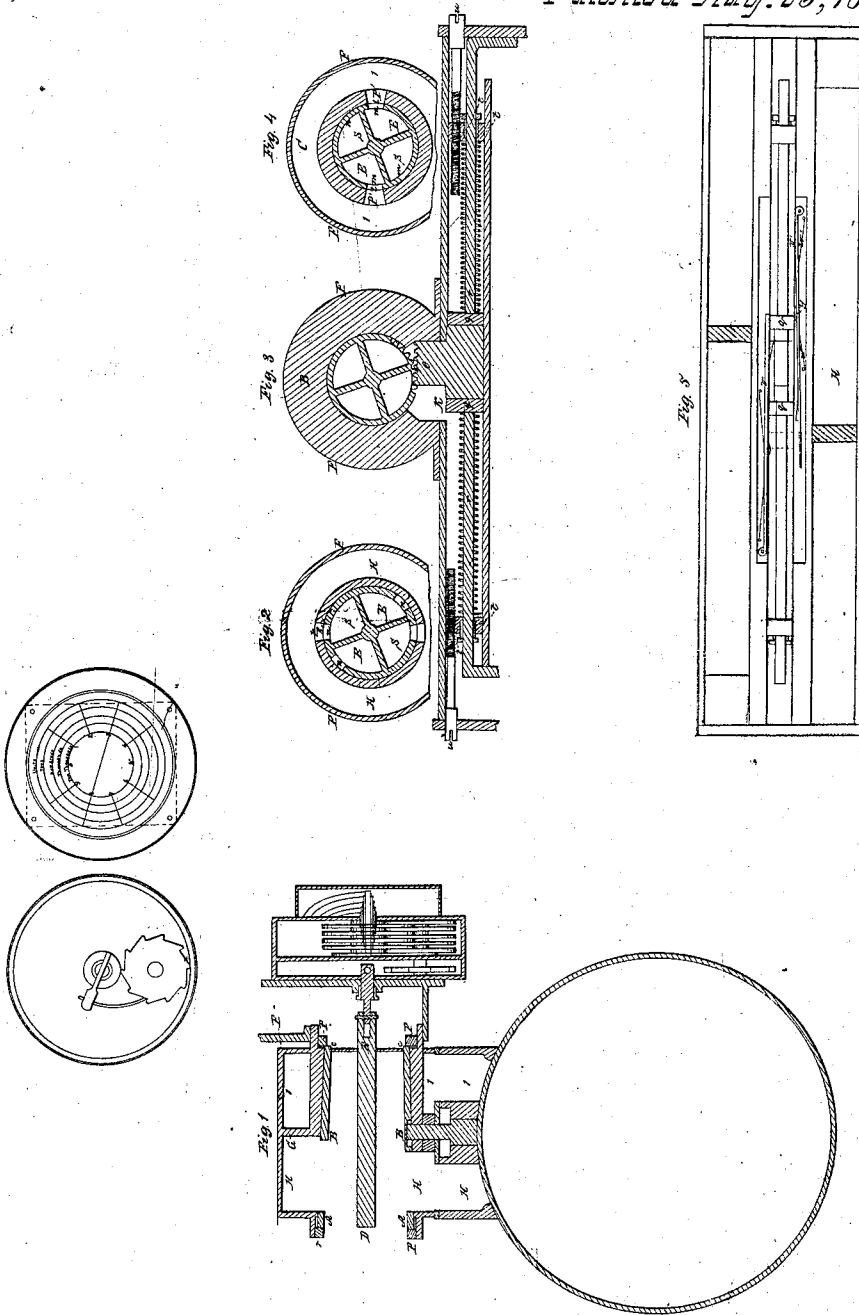

Witnesses,
Silvery
J. L. Combs

Inventor,
Herman Haupt
by
A. Pollock
his atty.

UNITED STATES PATENT OFFICE.

HERMAN HAUPT, OF CAMBRIDGE, MASSACHUSETTS.

ROTARY STEAM-VALVE.

Specification of Letters Patent No. 43,910, dated August 23, 1864.

To all whom it may concern:

Be it known that I, HERMAN HAUPT, of Cambridge, Massachusetts, have invented certain new and useful Improvements in Balance-Valves, applicable to all kinds of engines operated by air, gases, or steam, and also to gas or water meters, steam-hammers, drills, pile-drivers, mining machinery in general, riveting-machines, and other purposes; and I hereby declare that the following is a full, clear, and exact description of the same, reference being had to the accompanying drawings.

The valve subject of this patent can be so constructed as to cut off at any portion of the stroke, it can be worked from an eccentric, a rock-shaft, or an arm, or by a stud inside the cylinder moved by the piston itself. It can be by a peculiar arrangement be made to shift instantaneously when the piston has reached the end of its stroke, and not by a sliding or drawing movement as in most other valves. It is this peculiarity which renders possible the construction of a perfect water meter that will not permit the escape of any portion of water without registering it; the valve cannot shift until the stroke is fully completed and is then shifted by instantaneous action, the port being entirely open either for one end of the cylinder or the other. The following is a description of the means by which these results are accomplished: Figure 1, is a longitudinal section of the valve through the axis. Fig. 2, is a transverse section at the end A. Fig. 3, is a transverse section in the middle B. Fig. 4, is a transverse section at the small end C. Fig. 5, is a plan showing the springs for moving the valve and the arrangement of the ports to supply the cylinder.

The valve about to be described is particularly applicable to a rock drill, but is also applicable to meters and other purposes.

The valve consists of a frustum of a cone ground into and moving freely, and steam or air tight within another frustum which surrounds it. The valve is held in place by means of two rings p, p, p, p , which screw into the outer frustum or are adjusted by a screw from the outside which can be turned without removing the cap. They keep the valve perfectly tight as it wears, but prevent it from binding in its seat thus affording a simple and perfect adjustment.

The ends of the valve at D and E, are

closed by caps which screw on the projections on the outer cone and to these caps are attached the pipes which carry the live steam and the exhaust.

If the live steam be admitted at one end as D, the exhaust must pass out at the other end E.

The inner frustum is divided by longitudinal partitions into four quadrants; through two of these marked S, S, the steam is admitted, and through the other two E, E, the exhaust escapes.

The steam quadrants S, S, are open at the end of the frustum D, and closed at the end E.

The exhaust quadrants E, E, are closed at the end D, and open at the end E.

The outer frustum is surrounded by a cylindrical steam chest F, F, divided in the middle transversely by an annular partition G, forming two passages, one of which H, H, communicates with the right end of the cylinder, the other I, I, communicates with the left end.

In the outer frustum there are four openings or ports, two of which, p, p , communicate with the steam passages H, H, leading to the right end of the cylinder, and the other two, p', p' communicate with the steam passages I, I, leading to the left end of the cylinder. The width of the ports is equal to half the throw of the valve, and the length equal or nearly equal to the width of the steam passages H and I.

In the inner frustum which is movable, there must be double the number of ports or openings that required in the outer or fixed frustum; these ports at the end of the cylinder D, are marked n, n, n, n , and at the end E are marked m, m, m, m . As the valve rocks in its rear through an arc of 45° these ports n, n, n, n , two of which communicate with the steam quadrants S, S, and two with the exhaust quadrants E, E, are presented alternately to the ports p , which lead to and form the right end of the cylinder, while the ports m, m, m, m , are at the same time presented alternately to the openings p', p' , which lead to and from the left end of the cylinder.

The movement of the valve is effected by an arm or rack working in the slot K but it can also be vibrated in various other ways.

For steam drills, meters, and various other purposes, it is desirable that the valve

should be made without any external rods, arms or eccentrics, and that the movement should be instantaneous when the piston has finished its stroke. One of the devices for the accomplishment of these objects will now be described.

On the under side of the movable frustum, Fig. 3, there are teeth which work in a movable rack *o*, the extent of movement of the rack being sufficient to vibrate the valve 45°. In contact with the rack piece *o*, are two rectangular pieces *q*, *q*, which are attached to rods. These rods pass through movable pieces *t* *t*, furnished with stuffing boxes to exclude the steam, and turning downward into the cylinder are alternately moved a distance equal to the throw of the valve, by coming in contact with the piston within the cylinder. Between the pieces *q*, and *t*, the valve rods are surrounded by spiral springs, the stiffness of which is regulated by means of the screws *u*, *u*, which slide the pieces *t*, *t*, either way as may be required.

In Fig. 5 in addition to the pieces *q*, *q*, *t*, *t*, are shown triggers *v*, *v*, with light springs *w*, *w*, to keep them pressed gently against the pieces *q*, *q*.

The operation of the valve will now be described.

The piston being supposed to be at the end of its stroke at the right end of the cylinder, the valve is thrown to the right, the ports *n* and *p* are opposite, and allow the steam from the quadrants *s* to pass to the right end of the cylinder to commence the movement to the left, at the same time the ports *m* and *p'*, open communication with the left end of the cylinder for the escape of the exhaust. When the valve is thrown to the left, the ports *p*, *p*, communicate with the exhaust, and *p'*, *p'*, with the steam quadrants. When the piston in its movement toward the right end of the cylinder touches the valve rod at this end it does not move the valve, but simply compresses the spiral spring which surrounds the rod. As the movement is continued the piece *q* on the right side passes the projection *x*,

on the trigger *v*, which prevents the spring from relaxing until the trigger *x*, is released. The movement of the piston still continuing for say an eighth of an inch further, the piece *q* comes in contact with the projection *y*, on the trigger *v'*, and pressing it outward, releases the catch *x'*, on the left side of the rack piece *o*, when the spiral spring instantly acting moves the rack piece, and throws the valve to the right side opening the proper ports, and reversing the movement of the piston.

It will be perceived from this description that the valve is not moved directly by the piston, but by the sudden release of a bent spring, making its action instantaneous. The blow upon the valve rod is very slight, for it is detached from the valve when struck by the piston, and its office is simply to compress the spring and set the trigger for the next throw of the valve, while the valve itself is in equilibrium by the equal pressure of steam on opposite sides.

When a valve of this description is applied to engines which require a cut off, the valve is shifted by two movements, the first closing the steam port, and the second which must be twice as far as the first, opening the steam and exhaust ports for the other end, and this cut off can be made adjustable by placing the arm which throws the valve, at different distances from the ends of the cylinder.

What I claim as my invention and desire to secure by Letters Patent is—

An equilibrium valve constructed as described with reference to the steam, gas, air or water induction and eduction openings or passages and partitions for operation substantially as set forth.

In testimony whereof I have signed my name to this specification before two subscribing witnesses.

H. HAUPT.

Witnesses:

JABEZ A. SAWYER,
MICHAEL R. MULLEN.