



INTERNATIONAL APPLICATION PUBLISHED UNDER THE PATENT COOPERATION TREATY (PCT)

<p>(51) International Patent Classification ⁶ : B32B 5/08</p>	<p>A1</p>	<p>(11) International Publication Number: WO 99/06207</p> <p>(43) International Publication Date: 11 February 1999 (11.02.99)</p>
<p>(21) International Application Number: PCT/US98/15601</p> <p>(22) International Filing Date: 28 July 1998 (28.07.98)</p> <p>(30) Priority Data: 60/054,081 29 July 1997 (29.07.97) US</p> <p>(71) Applicant (for all designated States except US): INTERNATIONAL PAPER COMPANY [US/US]; Two Manhattanville Road, Purchase, NY 10577 (US).</p> <p>(72) Inventors; and (75) Inventors/Applicants (for US only): DHARMADHIKARY, Rahul [IN/US]; 840 County Street #211, Taunton, MA 02780 (US). CHU, Karen [US/US]; 1725 Orrington Avenue #231, Evanston, IL 60201 (US).</p> <p>(74) Agent: BROITMAN, Joshua, S.; Ostrager Chong Flaherty & Onofrio, 300 Park Avenue, New York, NY 10022-7402 (US).</p>		<p>(81) Designated States: CA, JP, MX, US, European patent (AT, BE, CH, CY, DE, DK, ES, FI, FR, GB, GR, IE, IT, LU, MC, NL, PT, SE).</p> <p>Published <i>With international search report.</i></p>
<p>(54) Title: SOFT NONWOVEN FABRIC MADE BY MELT EXTRUSION</p>		
<p>(57) Abstract</p>		
<p>A nonwoven fabric (2) having one or more layers of melt-extruded fibers (4, 6, 8) and having improved softness. The softness of the fabric (2) is improved by the addition of a softness-enhancing agent to a polyolefin melt prior to extrusion. The softness-enhancing agent is titanium dioxide (TiO₂) or an additive having an active ingredient which is an oligomeric ester or both. If TiO₂ is the only softness-enhancing agent in the polyolefin melt, then the percentage loading of the TiO₂ is preferably 1-10 % to achieve a desired enhanced softness. The TiO₂ is preferably rutile or anatase grade. The percentage loading of the oligomeric ester additive in the polyolefin melt is preferably 0.2-10 % to achieve a desired enhanced softness. The softness-enhancing agent can be added during the manufacture of a spunbond fabric, a spunbond/meltblown laminate, a spunbond/spunbond laminate, and SMS laminate or any other composite formed from spunbond and/or meltblown layers.</p>		

FOR THE PURPOSES OF INFORMATION ONLY

Codes used to identify States party to the PCT on the front pages of pamphlets publishing international applications under the PCT.

AL	Albania	ES	Spain	LS	Lesotho	SI	Slovenia
AM	Armenia	FI	Finland	LT	Lithuania	SK	Slovakia
AT	Austria	FR	France	LU	Luxembourg	SN	Senegal
AU	Australia	GA	Gabon	LV	Latvia	SZ	Swaziland
AZ	Azerbaijan	GB	United Kingdom	MC	Monaco	TD	Chad
BA	Bosnia and Herzegovina	GE	Georgia	MD	Republic of Moldova	TG	Togo
BB	Barbados	GH	Ghana	MG	Madagascar	TJ	Tajikistan
BE	Belgium	GN	Guinea	MK	The former Yugoslav Republic of Macedonia	TM	Turkmenistan
BF	Burkina Faso	GR	Greece	ML	Mali	TR	Turkey
BG	Bulgaria	HU	Hungary	MN	Mongolia	TT	Trinidad and Tobago
BJ	Benin	IE	Ireland	MR	Mauritania	UA	Ukraine
BR	Brazil	IL	Israel	MW	Malawi	UG	Uganda
BY	Belarus	IS	Iceland	MX	Mexico	US	United States of America
CA	Canada	IT	Italy	NE	Niger	UZ	Uzbekistan
CF	Central African Republic	JP	Japan	NL	Netherlands	VN	Viet Nam
CG	Congo	KE	Kenya	NO	Norway	YU	Yugoslavia
CH	Switzerland	KG	Kyrgyzstan	NZ	New Zealand	ZW	Zimbabwe
CI	Côte d'Ivoire	KP	Democratic People's Republic of Korea	PL	Poland		
CM	Cameroon	KR	Republic of Korea	PT	Portugal		
CN	China	KZ	Kazakstan	RO	Romania		
CU	Cuba	LC	Saint Lucia	RU	Russian Federation		
CZ	Czech Republic	LI	Liechtenstein	SD	Sudan		
DE	Germany	LK	Sri Lanka	SE	Sweden		
DK	Denmark	LR	Liberia	SG	Singapore		
EE	Estonia						

SOFT NONWOVEN FABRIC MADE BY MELT EXTRUSIONRelated Application

This application claims the benefit of U.S. Provisional Application No. 60/054,081, filed on July 29,
5 1997.

Field of the Invention

The invention relates to nonwoven fabric suitable for use as a component in a disposable diaper. In particular, the invention relates to nonwoven fabric
10 comprising one or more layers of melt-extruded fibers.

Background of the Invention

Nonwoven webs and laminates thereof have application in a variety of disposable products, including wipers, garments, medical drapes and absorbent articles
15 such as diapers. One class of such nonwoven web laminates is commonly referred to as spunbonded/meltblown/spunbonded (SMS) laminates. These SMS laminates generally consist of nonwoven outer layers of spunbonded polyolefins and an interior layer of meltblown polyolefins.
20

As used herein, the term "nonwoven web" refers to a web that has a structure of individual fibers or filaments which are interlaid, but not in an identifiable repeating pattern.

25 As used herein, the term "spunbonded fibers" refers to fibers which are formed by extruding molten thermoplastic material as filaments from a plurality of fine, usually circular capillaries of a spinnerette. Cooling

-2-

air is fed to a quenching chamber wherein the filaments are cooled. The cooling air is then sucked through a nozzle, which accelerates the flow of air. The friction between the flowing air and the filaments creates a force which draws the filaments, i.e., attenuates the filaments to a smaller diameter. The drawn filaments are then passed through a diffusor and deposited on a conveyor belt to form a nonwoven web. A conventional spinbonding technique is disclosed in U.S. Patent No. 4,340,563 to Appel.

As used herein, the term "meltblown fibers" refers to fibers which are formed by extruding molten thermoplastic material as threads or filaments through a plurality of fine, usually circular capillaries of a die. A high-velocity, usually heated gas (e.g., air) stream attenuates the filaments of molten thermoplastic material to reduce their diameter. Thereafter the meltblown fibers are carried by the high-velocity heated gas stream and are deposited on a collecting surface to form a web of randomly dispersed meltblown fibers. A conventional meltblowing technique is disclosed in U.S. Patent No. 4,707,398 to Boggs.

Meltblown fibers differ from spunbonded fibers in that the extruded polymer strands have much finer diameters. These fine diameter filaments are easily dispersed by the forced hot air stream before being deposited on the collecting surface. In addition, the meltblown fibers are substantially cooled by the air so that they do not significantly bond together. Bonding of the web to retain integrity and strength occurs as a separate downstream operation.

SMS fabrics lack the softness and feel of carded fabrics. The key problem is the presence of the central meltblown layer, which causes the SMS structure to become stiff/harsh upon calendaring. Although the softness of the SMS composite can be improved by

-3-

reducing the meltblown content, i.e., by reducing the basis weight of the meltblown layer, a need exists to further increase the softness of the SMS composite. Further, there is a need to improve the softness of spunbond nonwoven fabric.

Summary of the Invention

The present invention is a nonwoven fabric comprising one or more layers of melt-extruded fibers and having improved softness. The softness of the fabric is improved by the addition of a softness-enhancing agent to a polyolefin melt prior to extrusion.

The softness-enhancing agent in accordance with one preferred embodiment is titanium dioxide (TiO_2). If TiO_2 is the only softness-enhancing agent in the polyolefin melt, then the percentage loading of TiO_2 is preferably 1-10% to achieve a desired enhanced softness. The TiO_2 is preferably rutile or anatase grade.

The softness-enhancing agent in accordance with another preferred embodiment is an additive having an active ingredient which is an oligomeric ester. The percentage loading of this additive in the polyolefin melt is preferably 0.2-10% to achieve a desired enhanced softness. The oligomeric ester preferably belongs to the class which increases the hydrophilicity of the polyolefin fibers. Alternatively, the oligomeric ester may belong to the class which increases the hydrophobicity of the polyolefin fibers.

In accordance with a further preferred embodiment of the invention, both TiO_2 and the oligomeric ester agent are added to the polyolefin melt prior to extrusion. In this case the TiO_2 loading can be reduced to 0.2-4%.

The invention can be applied in the manufacture of a spunbond fabric, a spunbond/meltblown laminate, a spunbond/spunbond laminate, an SMS laminate or any other

-4-

composite formed from spunbond and/or meltblown layers. In accordance with the preferred embodiment of an SMS fabric, the softness-enhancing agents are added only to the spunbond melts. Alternatively, the softness-enhancing agents can also be added to the meltblown melt.

The addition of TiO_2 alone in accordance with the invention results in a fabric having increased softness and increased opacity. The addition of both TiO_2 and hydrophilic oligomeric ester agent in accordance with the invention produces a fabric having increased softness, increased opacity, decreased coefficient of friction, and increased hydrophilicity. The addition of both TiO_2 and hydrophobic oligomeric ester agent in accordance with the invention produces a fabric having increased softness, increased opacity, decreased coefficient of friction, and increased hydrophobicity.

Brief Description of the Drawings

FIG. 1 is a schematic diagram showing the construction of a conventional spunbonded/meltblown/spunbonded fiber laminate.

FIG. 2 is a schematic diagram showing the essential components of a system for continuously producing nonwoven web material having enhanced softness in accordance with the present invention.

Detailed Description of the Preferred Embodiments

The present invention can be incorporated in a nonwoven composite material 2 of the type shown in FIG. 1. This nonwoven composite 2 comprises a meltblown fabric layer 4 of thermoplastic polymeric microfibers sandwiched between two spunbonded fabric layers 6 and 8 each made of thermoplastic polymer filaments. In accordance with one preferred embodiment, only the spunbonded layers contain the softness-enhancing agents of the present invention. In the alternative, the

-5-

softness-enhancing agents can also be added to the meltblown polymer.

The meltblown fabric layer 4 can be prepared by extruding a fiber-forming thermoplastic polymer resin in molten form through a plurality of fine, usually circular capillaries of a die. A high-velocity, usually heated gas (e.g., air) stream attenuates the filaments of molten thermoplastic material to reduce their diameter. Thereafter the meltblown fibers are carried by the high-velocity heated gas stream and are deposited on a collecting surface to form a nonwoven web of randomly dispersed meltblown fibers. In accordance with the preferred embodiment, the thermoplastic polymeric microfibers of meltblown fabric layer 4 are polypropylene. Polymers other than polypropylene, such as nylon, polyethylene, polyester, and copolymers and blends thereof, may also be used.

Each of the spunbonded fabric layers 6 and 8 may be produced by continuously extruding a thermoplastic polymer through a plurality of fine, usually circular capillaries of a spinnerette. Pressurized cooling air is fed to a quenching chamber wherein the filaments are cooled. The cooling air is then accelerated through a nozzle by a positive air pressure. The friction between the flowing air and the filaments creates a force which draws the filaments, i.e., attenuates the filaments to a smaller diameter. The filaments are drawn to achieve molecular orientation and tenacity. The continuous filaments are then deposited in a substantially random manner to form a web of substantially continuous and randomly arranged, molecularly oriented filaments. The preferred thermoplastic polymer used to make spunbonded fabric layers 6 and 8 is polypropylene, although nylon, polyethylene, polyester, and copolymers and blends thereof can be used.

-6-

In accordance with the conventional structure of an SMS fabric as seen in FIG. 1, the meltblown (MB) fabric layer 4 is sandwiched between two spunbonded (SB) fabric layers 6 and 8. All three of these fabric layers are then bonded together by the application of heat and pressure to form the SMS fabric laminate 2.

FIG. 2 shows a production line 10 for producing an SMS fabric laminate 2 in accordance with the present invention. This production line can be operated at a speed in the range of 250 to 600 m/min, preferably about 375 m/min. The equipment of production line 10 consists of an endless foraminous forming belt 12 wrapped around rollers 14 and 16. The belt 12 is driven in the direction shown by the arrows. The production line 10 includes a forming machine which has three stations: spunbond station 18, meltblown station 20 and spunbond station 22. First, the spunbond station 18 lays down a web 8 of spunbonded fibers 28 onto the carrier belt 12. Then the meltblown station 20 lays down a web 4 of meltblown fibers 26 onto the spunbonded web 8. Lastly, the spunbond station 22 lays down a web 6 of spunbonded fibers 30 onto the meltblown web 4. Alternatively, each of the component fabric layers may be formed separately, rolled, and later converted to the SMS fabric laminate offline.

The spunbond stations 18 and 22 are conventional extruders with spinnerettes which form continuous filaments of a polymer and deposit those filaments onto the forming belt 12 in a random interlaced fashion. Each spunbond station may include one or more spinnerette heads depending on the speed of the process and the particular polymer being used. Forming spunbonded material is a conventional process well known in the art.

The meltblown station 20 consists of a die 24 which is used to form microfibers 26. As the thermoplastic

-7-

polymer exits the die 24, the polymer threads are attenuated and spread by high-pressure fluid, usually air, to form microfibers 26. The microfibers 26 are randomly deposited on top of the spunbond layer 8 and form a meltblown layer 4. The construction and operation of the meltblown station 20 for forming microfibers 26 are well known in the art.

In accordance with the broad concept of the present invention, the basis weight of the meltblown fabric layer can be in the range of 0.5 to 15.0 gsm, while the total basis weight of the spunbonded fabric layers can be in the range of 5.0 to 50.0 gsm. Further, in accordance with the invention, the meltblown fibers have an average diameter of 1-10 μm , preferably 3-5 μm , while the spunbonded fibers have an average diameter of 10-30 μm , preferably 12-20 μm . The SMS fabric laminate in accordance with the preferred embodiment has a mean pore size in the range of 15-50 μm , preferably about 30-40 μm . The molten polypropylene used to make the meltblown fibers has a molecular weight distribution in the range of about 1.8-5.0, preferably 3.6, and a melt flow rate in the range of about 400-3000 grams/10 minutes, preferably about 1000 grams/10 minutes, whereas the molten polypropylene used to make the spunbonded fibers has a molecular weight distribution in the range of about 1.8-5.0, preferably 2.5-2.7, and a melt flow rate in the range of about 10-100 grams/10 minutes, preferably about 35 grams/10 minutes.

Out of the forming machine, the SMS fabric laminate web 2 (see FIG. 2) is then fed through bonding rolls 32 and 34. The surfaces of the bonding rolls 32 and 34 are provided with a pattern of raised lands which apply heat and pressure to thermally spot bond the three layers together. The bonding rolls are heated to a temperature which causes the meltblown polymer to soften. As the meltblown web 4 passes between the heated bonding rolls

-8-

32 and 34, the composite material is compressed and heated by the bonding rolls in accordance with the pattern on the rolls to create a pattern of discrete bonding areas. Such discrete area or spot bonding is well known in the art and can be carried out by means of heated rolls or by ultrasonic bonding. The bond pattern is selected to provide desired fabric strength characteristics. The pattern bonding area is not limited in accordance with the present invention, although pattern bonding areas in the range of 5-25%, preferably 14-19%, of the total fabric area are feasible. In the alternative, the laminate can be ultrasonically spot bonded or bonded by hot melt/glue adhesive lamination.

In accordance with a further preferred embodiment of the invention, a spunbonded/spunbonded (SS) fabric laminate is formed by operating only spunbond stations 18 and 22, i.e., meltblown station 20 is turned off. The softness-enhancing agents of the present invention can be added to either or both spun beams. In this case, the bonding rolls 32 and 34 must be heated to a temperature which causes the spunbonded polymer to soften. The SS fabric laminate will have the same tensile strength and elongation as an SMS fabric laminate having the same spunbonded layers since the meltblown layer does not contribute to these physical properties.

In accordance with a further preferred embodiment of the present invention, a monolayer of spunbond fabric having enhanced softness can be fabricated. In this case, both the meltblown station 20 and the second spunbond station 22 are turned off, and the softness-enhancing agent is added to the polymer being fed to the operating spunbond station.

In accordance with one method of manufacture of the invention, TiO_2 is compounded with a base resin to form a masterbatch. This masterbatch is then mixed at a low percentage with the primary resin being fed to one or

-9-

more stations. The primary and base resins may be different or the same. In accordance with a second method of manufacture of the invention, a hydrophilic additive is compounded with a base resin to form a masterbatch, which is then mixed at a low percentage with the primary resin being fed to one or more stations. Alternatively, the masterbatch can be formed by compounding both TiO₂ and hydrophilic additive with a base resin and then mixing the masterbatch with the main resin before feeding the polymer melt to the extruder. The preferred base and primary resins are polyolefins. In particular, the primary resin is preferably polypropylene, while the base resin is preferably either polyethylene or polypropylene.

In a first trial run, a masterbatch consisting of 70% TiO₂ and 30% polyethylene (PE) was compounded with molten polypropylene (PP) to produce spunbond fabric samples having a basis weight of 25 gsm. The letdown was 4%, giving a melt composition of 2.8% TiO₂, 1.2% polyethylene and 96% polypropylene. The fabric softness and opacity, as evaluated subjectively, were considerably higher than those for a 100% polypropylene spunbond control sample (i.e., 0% TiO₂). The processing conditions during this trial were similar for the control samples and the TiO₂/PE masterbatch samples. The fabric uniformity was also comparable.

A second trial run was made to evaluate the influence of TiO₂ in an SMS configuration. A masterbatch consisting of 70% TiO₂ and 30% polyethylene (PE) was compounded with molten polypropylene (PP) only in the spunbond melts. The meltblown layer was formed from polypropylene without TiO₂ or polyethylene. SMS composites having a meltblown layer of varying basis weight were produced, as set forth in the following table:

-10-

TABLE 1

	Total Weight (gsm)	MB Weight (gsm)	SB Weight (gsm)
5	18.0	1.0	17.0
	15.5	2.5	13.0
	15.5	1.0	14.5
10	12.0	0.6	11.4

Also an SMS composite having a total basis weight of 15.5 gsm with a 2.5-gsm meltblown layer was produced using a masterbatch consisting of 70% TiO₂ and 30% polypropylene at letdowns of 2% and 4%, i.e., the spunbond melt compositions were, respectively, 1.4% TiO₂/98.6% polypropylene (2% letdown) and 2.8% TiO₂/97.2% polypropylene (4% letdown). There was a significant improvement in softness for all SMS samples in which the spunbond layers incorporated TiO₂. However, fabric uniformity was poorer compared to SMS control samples made with 0.27% TiO₂.

In order to study the influence of polyethylene alone on the softness of polypropylene melt-extruded fabric, a masterbatch consisting of 50% polypropylene and 50% polyethylene was compounded with molten polypropylene at 6% letdown for the spunbond melts, i.e., the spunbond melt composition was 3.0% polyethylene/97% polypropylene. Again the meltblown melt consisted of polypropylene without TiO₂ or polyethylene. These melts were used to produce SMS composites having a total basis weight of 15.5 gsm with meltblown basis weights of 2.5 and 1.0 gsm, respectively. No significant improvement in softness was observed compared to the polypropylene control samples.

In another trial run, a masterbatch consisting of 50% TiO₂ and 50% polyethylene was compounded with polypropylene to produce spunbond fabric samples having a basis weight of 20 gsm. Letdowns of 6%, 4% and 2% were used, giving melt compositions of 3.0% TiO₂/3.0% polyethylene/94% polypropylene, 2.0% TiO₂/2.0% polyethy-

-11-

lene/96% polypropylene, and 1.0% TiO₂/1.0% polyethylene/
98% polypropylene, respectively. Similarly, spunbond
fabric was fabricated from a masterbatch consisting of
50% TiO₂ and 50% polypropylene compounded with polypro-
5 polyene at letdowns of 6%, 4% and 2%. In these cases,
the melt compositions were 3.0% TiO₂/97% polypropylene,
2.0% TiO₂/98% polypropylene, and 1.0% TiO₂/99% polypro-
pylene, respectively. Again significant improvements
in softness and opacity were observed.

10 In accordance with the present invention, the TiO₂
loading can be in the range of 1-10%, with about 2%
being preferred. Either rutile or anatase types of TiO₂
can be used. The trials demonstrated that masterbatches
consisting of TiO₂ compounded with either polyethylene
15 or polypropylene provide enhanced softness when added
to a polypropylene spunbond melt. Initial observations
indicated that the polyethylene-based masterbatch pro-
vided better softness than that provided by the polypro-
pylene-based masterbatch. In addition, the softness of
20 an SMS composite can be enhanced by adding TiO₂ to one
of the spunbond layers, but not to the other spunbond
layer and not to the meltblown layer. Similarly, the
softness of an SS composite can be enhanced by adding
TiO₂ to one but not the other spunbond layer.

25 In accordance with a further preferred embodiment
of the invention, the softness of spunbond, SMS or other
melt-extruded fabrics can be enhanced using a melt
additive which migrates to the surface during fiber
formation. In particular, an oligomeric ester additive
30 was used to enhance the softness of a polypropylene
spunbond fabric. This additive increased the softness
at the level of 0.5% or more. The melt additive was
durable since it did not wash away after the first
insult.

35 A trial run was made in which a masterbatch con-
sisting of 25% hydrophilic oligomeric ester additive

-12-

and 75% polypropylene, with a final melt flow rate of approximately 60 grams/10 minutes (PPM 11186 from Techmar PM, Rancho Dominguez, California), was compounded with polypropylene to produce spunbond fabric samples having a basis weight of about 24 gsm. Two levels of letdown were utilized: 2% and 10%, giving a final concentration of hydrophilic oligomeric ester additive in the spunbond melt of 0.5% and 2.5%, respectively. The throughput of the spunbond station was 0.35 gm/hr/min; the spunbond fabric was spot bonded with the top and bottom bonding rolls having temperatures of 272°F and 269°F, respectively.

The resulting spunbond fabrics had improved softness compared to the control samples made from polypropylene without hydrophilic oligomeric ester additive and the softness improved with increasing levels of additive. The physical properties of the samples incorporating hydrophilic oligomeric ester additive are listed in Table 2:

TABLE 2

Property	Hydrophilic Additive Concn.		
	0%	0.5%	2.5%
Basis Weight (gsm)	25.4	23.4	23.8
Thickness (mils)	11.13	9.4	8.4
MD Tensile (gm/in.)	3010	2946	2750
MD Elongation @ Break (%)	44.7	82	97
CD Tensile (gm/in.)	1336	1543	1512
CD Elongation @ Break (%)	58.4	81.6	93.1

In accordance with a further aspect of the present invention, both TiO₂ and hydrophilic additive can be added to the masterbatch to further enhance the softness of a melt-extruded, e.g., spunbond, fabric. To demonstrate this point, a trial run was made in which a masterbatch consisting of 30% hydrophilic additive, 20% TiO₂ and 50% polypropylene was compounded with polypropylene to produce spunbond fabric samples having a basis weight of about 23 gsm. Two levels of letdown were

-13-

utilized: 4% and 7.5%, giving a final concentration of hydrophilic additive in the spunbond melt of 1.2% and 2.2%, respectively, and a final concentration of TiO₂ in the spunbond melt of 0.8% and 1.5%, respectively. The throughput of the spunbond station was 0.30 gm/hr/min; the spunbond fabric was spot bonded with the top and bottom bonding rolls both having a temperature of 272°F.

The throughput for the second trial was 0.30 gm/hr/min as compared to 0.35 gm/hr/min for the first trial. Furthermore, the softness and opacity were considerably better compared to the previous trial run due to the addition of TiO₂. The physical properties of the spunbond fabric incorporating both hydrophilic oligomeric ester additive and TiO₂ are listed in Table 3:

15

TABLE 3

Property	Hydrophilic Additive Concn.		
	0%	1.2%	2.2%
Basis Weight (gsm)	23.0	22.6	23.2
Thickness (mils)	6.7	8.3	8.4
MD Tensile (gm/in.)	3006	3329	3351
MD Elongation @ Break (%)	50.4	79.5	93.9
CD Tensile (gm/in.)	1141	1412	1505
CD Elongation @ Break (%)	57.1	87.6	109.6
Coeff. of Friction	0.63	0.33	0.3

The coefficient of friction was measured in accordance with ASTM Standard D 1894-75, "Static and Kinetic Coefficients of Friction of Plastic Film and Sheeting," American Society for Testing and Materials, Part 35 (1977), pp. 575-580. Compared to coefficient of friction values of 0.63 for the control sample, the samples with 1.2% hydrophilic oligomeric ester additive had a coefficient of friction of 0.33 and the samples with 2.2% hydrophilic oligomeric ester additive had a coefficient of friction of 0.3, indicating a significant improvement in softness.

-14-

For spunbond fabric, the preferred levels for the hydrophilic oligomeric ester additive and the TiO_2 are 0.2-10% and 0.2-4%, respectively. When fabricating SMS fabrics, different levels of hydrophilic oligomeric ester additive can be incorporated in the melt and spun beams to improve the strikethrough and rewet properties. In addition, hydrophilic agents can be applied topically to further enhance hydrophilicity.

To further test the concept of adding hydrophilic oligomeric ester agents to enhance softening, trial runs were conducted in which SS and spunbond fabric were fabricated. In trial runs, SS composites having basis weights of 12.5, 14.2 and 17.0 gsy were fabricated using a masterbatch consisting of 30% hydrophilic additive, 20% TiO_2 and 50% polypropylene (PPM 11253 from Techmar PM). The masterbatch was compounded with polypropylene of both spun beams at a letdown of 4%, giving final concentrations of hydrophilic oligomeric ester additive and TiO_2 in the spunbond melts of 1.2% and 0.8%, respectively. The same hydrophilic agent/ TiO_2 masterbatch was used to fabricate an SS composite having a basis weight of 14.2 gsy, except that the masterbatch was compounded with polypropylene of both spun beams at a letdown of 2.5%, giving final concentrations of hydrophilic oligomeric ester additive and TiO_2 in the spunbond melts of 0.75% and 0.5%, respectively. In addition, control SS samples without softness-enhancing agents and having basis weights of 12.5, 14.2 and 17.0 gsy were fabricated. The SS composites with oligomeric ester and TiO_2 additives had significantly improved softness compared to the control samples. The physical properties of the control SS samples and of the foregoing SS and spunbond fabrics are listed in Tables 4 and 5 respectively:

-15-

TABLE 4 - CONTROLS

5	Property	Final TiO ₂ Concn.		
		0.5%	0.5%	0.5%
	Basis Weight (gsy)	12.5	14.2	17
	Thickness (mils)	8.1	8.5	9.3
	MD Tensile (gm/in.)	1412	1848	1764
10	MD Elongation @ Break (%)	69	90	80
	CD Tensile (gm/in.)	535	741	1156
	CD Elongation @ Break (%)	77	82	95
	Coeff. of Friction	0.57	0.54	0.62

15

TABLE 5 - WITH ADDITIVE IN BOTH BEAMS

20	Property	TiO ₂ : Add.:	Final Additive Concn.			
			0.8%	0.8%	0.8%	0.5%
		1.2%	1.2%	1.2%	0.75%	
	Basis Weight (gsy)	12.5	14.2	17	14.2	
	Thickness (mils)	7.3	7.2	9.4	7	
	MD Tensile (gm/in.)	1364	1463	1364	1559	
25	MD Elongation @ Break (%)	87	85	103	81	
	CD Tensile (gm/in.)	484	655	861	715	
	CD Elongation @ Break (%)	72	87	196	85	
	Coeff. of Friction	0.23	0.28	0.26	0.25	

30

TABLE 6 - ADDITIVE IN ONE BEAM ONLY

35	Property	Beam 1 - Add.: Beam 2 - TiO ₂ : - Add.:	Final Additive Concn.		
			0.15%	0.15%	0.15%
		0.75%	0.75%	0.75%	
		0.5%	0.5%	0.5%	
	Basis Weight (gsy)	12.5	14.2	17	
	Thickness (mils)	7.8	7.6	10	
40	MD Tensile (gm/in.)	1475	1496	2018	
	MD Elongation @ Break (%)	87	87	97	
	CD Tensile (gm/in.)	614	502	941	
	CD Elongation @ Break (%)	79	69	93	
45	Coeff. of Friction	0.32	0.33	0.34	

50

Further trial runs were made in which SS fabric was fabricated with one spun beam comprising polypropylene with 0.15% TiO₂ and no oligomeric ester and the other spun beam comprising polypropylene compounded with a masterbatch consisting of 30% hydrophilic oligomeric ester additive, 20% TiO₂ and 50% polypropylene. The masterbatch was compounded with polypropylene at a

-16-

letdown of 5.0%. The final concentration of hydrophilic oligomeric ester additive and TiO_2 in the spunbond was 0.75% and 0.5%, respectively. The softness at the 5% level in one beam was lower than that for 2.5% in two beams. The physical properties of the foregoing SS fabric are listed in Table 6.

Further trial runs were made to test the effect of adding hydrophilic oligomeric ester agents to enhance softness characteristics in SMS composites. In these runs, SMS composites having basis weights of 13 and 11.5 gsy were fabricated using a masterbatch consisting of 25% hydrophilic additive and 75% polypropylene (11186 from Techmar PM) at letdown rates of 3% and 5% in both spunbond beams, yielding final concentrations of 0.75% and 1.25%, respectively. The hydrophilic additive was not used in the meltblown beam. A white masterbatch of 50% TiO_2 and 50% polypropylene was used in conjunction with hydrophilic additive at a letdown rate of 0.33%, yielding a final concentration of 0.17%, respectively. TiO_2 was not used in the meltblown beam. Samples containing TiO_2 but not the hydrophilic additive were also produced at basis weights of 13 and 11.5 gsy. The physical properties of the 13-gsy SMS fabric containing TiO_2 with and without the hydrophilic additive are listed in Table 7.

TABLE 7

Property	Final Hydrophilic Additive Concn.		
	0%	0.75%	1.25%
Basis Weight (gsy)	13.0	13.24	12.92
Thickness (mils)	6.8	7.57	7.37
MD Tensile (gm/in.)	1600	1715	1644
MD Elongation @ Break (%)	65	59	56
CD Tensile (gm/in.)	838	814	791
CD Elongation @ Break (%)	68	58	58
Coeff. of Friction	0.56	0.35	0.34

-17-

The SMS composites with the oligomeric ester and TiO₂ had significantly improved softness characteristics as measured by coefficient of friction. The samples with 0.75% and 1.25% had coefficients of friction of 5 0.35 and 0.34 respectively, compared with 0.56 for the sample without additive. The letdown and final concentration of the oligomeric ester can be adjusted to effect hydrophobic or hydrophilic properties. In this case, the hydrophobicity of the SMS composites with the 10 oligomeric ester matched that of SMS composites having no oligomeric ester. The level of hydrophilic oligomeric ester additive can be increased in order to achieve hydrophilic properties. In addition, hydrophilic agents can be used to treat the fabrics topically 15 to further enhance hydrophilicity.

The preferred embodiments of the invention have been disclosed for the purpose of illustration. Variations and modifications of the disclosed preferred 20 embodiments which fall within the concept of this invention will be readily apparent to persons skilled in the art. All such variations and modifications are intended to be encompassed by the claims set forth hereinafter.

-18-

Claims

1. A nonwoven fabric comprising a first nonwoven ply of melt-extruded polyolefinic fibers incorporating a first softness-enhancing agent.

2. The nonwoven fabric as defined in claim 1, wherein said first softness-enhancing agent is TiO_2 in an amount in the range of 1% to 10% of the weight of said fibers.

3. The nonwoven fabric as defined in claim 1, wherein said first softness-enhancing agent is an oligomeric ester additive in an amount in the range of 0.2% to 10% of the weight of said fibers.

4. The nonwoven fabric as defined in claim 3, wherein said melt-extruded polyolefinic fibers further incorporates a second softness-enhancing agent, said second softness-enhancing agent being TiO_2 in an amount
5 in the range of 0.2% to 4% of the weight of said fibers.

5. The nonwoven fabric as defined in claim 1, wherein said melt-extruded polyolefinic fibers of said first ply are spunbonded.

6. The nonwoven fabric as defined in claim 1, wherein said melt-extruded polyolefinic fibers are meltblown.

7. The nonwoven fabric as defined in claim 1, further comprising a second nonwoven ply of spunbonded polyolefinic fibers laminated to said first nonwoven ply.

-19-

8. The nonwoven fabric as defined in claim 1, further comprising a second nonwoven ply of meltblown polyolefinic fibers laminated to said first nonwoven ply.

9. The nonwoven fabric as defined in claim 8, further comprising a third nonwoven ply of spunbonded polyolefinic fibers laminated to said second nonwoven ply.

10. The nonwoven fabric as defined in claim 3, wherein said oligomeric ester additive is hydrophilic.

11. The nonwoven fabric as defined in claim 3, wherein said oligomeric ester additive is hydrophobic.

12. The nonwoven fabric as defined in claim 1, wherein said fabric has a coefficient of friction less than 0.5.

13. A method of manufacturing a nonwoven web having enhanced softness, comprising the steps of:

mixing a first softness-enhancing agent with a base resin to form a masterbatch;

5 mixing said masterbatch at a predetermined percentage with a primary resin to form a melt;

extruding said melt through a multiplicity of capillaries of a melt extrusion device to form a multiplicity of filaments; and

10 depositing said filaments on a collecting surface to form a nonwoven web of randomly dispersed fibers, wherein said base resin and said primary resin are polyolefins.

14. The method as defined in claim 13, wherein said first softness-enhancing agent is TiO_2 in an amount

-20-

in the range of 1% to 10% of the weight of said melt.

15. The method as defined in claim 13, wherein said first softness-enhancing agent is an oligomeric ester additive in an amount in the range of 0.2% to 10% of the weight of said melt.

16. The method as defined in claim 15, wherein said oligomeric ester additive is hydrophilic.

17. The method as defined in claim 15, wherein said oligomeric ester additive is hydrophobic.

18. The method as defined in claim 15, further comprising the step of mixing a second softness-enhancing agent with said base resin to form said masterbatch, wherein said second softness-enhancing agent is TiO_2 in an amount in the range of 0.2% to 4% of the weight of said melt.

19. The method as defined in claim 13, wherein said base resin is polyethylene and said primary resin is polypropylene.

1/1

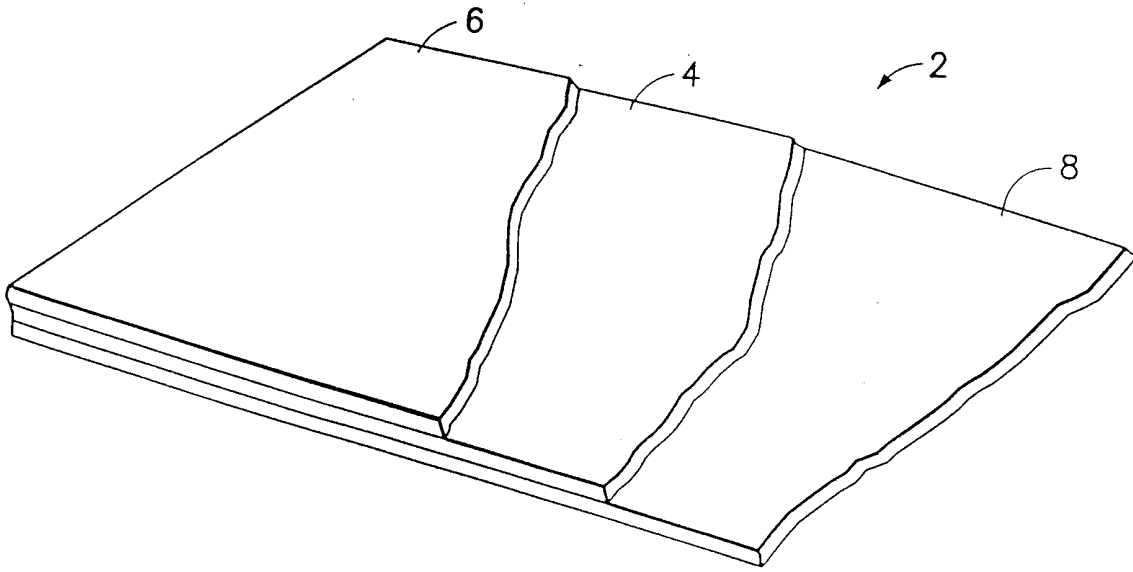

FIG. 1

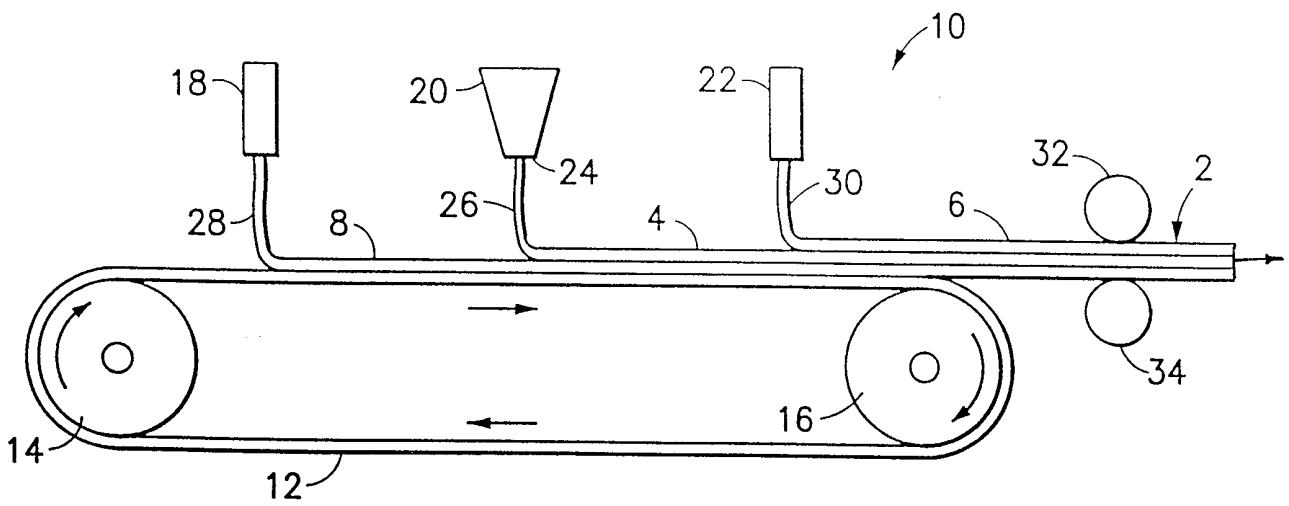

FIG. 2

INTERNATIONAL SEARCH REPORT

International application No.
PCT/US98/15601

A. CLASSIFICATION OF SUBJECT MATTER
IPC(6) : B32B 5/08
US CL : 442/401, 102
According to International Patent Classification (IPC) or to both national classification and IPC

B. FIELDS SEARCHED

Minimum documentation searched (classification system followed by classification symbols)
U.S. : 442/401, 102

Documentation searched other than minimum documentation to the extent that such documents are included in the fields searched

Electronic data base consulted during the international search (name of data base and, where practicable, search terms used)

C. DOCUMENTS CONSIDERED TO BE RELEVANT

Category*	Citation of document, with indication, where appropriate, of the relevant passages	Relevant to claim No.
X --- A	US 4,753,834 A (BRAUN et al.) 28 June 1988, see column 8.	1-2, 5-9, 12-14 ----- 3-4, 10-11, 15-19
X,P ---- A,P	US 5,705,249 A (TAKAI et al.) 06 January 1998, see column 3.	1-2, 5-9, 12-14 ----- 3-4, 10-11, 15-19
Y	US 3,770,562 A (NEWMAN) 06 Novemeber 1973, see entire document.	1-19

Further documents are listed in the continuation of Box C. See patent family annex.

* Special categories of cited documents:	*T* later document published after the international filing date or priority date and not in conflict with the application but cited to understand the principle or theory underlying the invention
A document defining the general state of the art which is not considered to be of particular relevance	*X* document of particular relevance; the claimed invention cannot be considered novel or cannot be considered to involve an inventive step when the document is taken alone
E earlier document published on or after the international filing date	*Y* document of particular relevance; the claimed invention cannot be considered to involve an inventive step when the document is combined with one or more other such documents, such combination being obvious to a person skilled in the art
L document which may throw doubts on priority claim(s) or which is cited to establish the publication date of another citation or other special reason (as specified)	* & * document member of the same patent family
O document referring to an oral disclosure, use, exhibition or other means	
P document published prior to the international filing date but later than the priority date claimed	

Date of the actual completion of the international search 21 SEPTEMBER 1998	Date of mailing of the international search report 22 OCT 1998
--	--

Name and mailing address of the ISA/US Commissioner of Patents and Trademarks Box PCT Washington, D.C. 20231 Facsimile No. (703) 305-3230	Authorized officer <i>Terrel Morris</i> TERREL MORRIS Telephone No. (703) 308-0661
---	--