



INTERNATIONAL APPLICATION PUBLISHED UNDER THE PATENT COOPERATION TREATY (PCT)

<p>(51) International Patent Classification <sup>6</sup> : H01L 21/302, 21/263</p>	<p>A1</p>	<p>(11) International Publication Number: <b>WO 98/24118</b> (43) International Publication Date: 4 June 1998 (04.06.98)</p>
<p>(21) International Application Number: PCT/IB97/01186 (22) International Filing Date: 29 September 1997 (29.09.97) (30) Priority Data: 9624715.0 28 November 1996 (28.11.96) GB (71) Applicant: PHILIPS ELECTRONICS N.V. [NL/NL]; Groenewoudseweg 1, NL-5621 BA Eindhoven (NL). (71) Applicant (for SE only): PHILIPS NORDEN AB [SE/SE]; Kottbygatan 7, Kista, S-164 85 Stockholm (SE). (72) Inventors: McCULLOCH, David, James; Prof. Holstlaan 6, NL-5656 AA Eindhoven (NL). BROTHERTON, Stanley, David; Prof. Holstlaan 6, NL-5656 AA Eindhoven (NL). (74) Agent: STEVENS, Brian, T.; Internationaal Octrooibureau B.V., P.O. Box 220, NL-5600 AE Eindhoven (NL).</p>	<p>(81) Designated States: JP, KR, European patent (AT, BE, CH, DE, DK, ES, FI, FR, GB, GR, IE, IT, LU, MC, NL, PT, SE).  <b>Published</b> <i>With international search report.</i> <i>Before the expiration of the time limit for amending the claims and to be republished in the event of the receipt of amendments.</i></p>	

(54) Title: ELECTRONIC DEVICE MANUFACTURE BY ENERGY BEAM CRYSTALLISATION

(57) Abstract

The invention provides a method of manufacturing a large-area electronic device, for example a flat panel display, comprising thin-film circuit elements, and also laser apparatus for crystallising a portion of a semiconductor thin-film (1) with a beam (11) of set energy. The energy of the beam (11) is set in accordance with the output from a light detector (22) to regulate the crystallisation of a device portion (3, 4 and/or 5) of a semiconductor thin film (1) at which the beam (11) is subsequently directed with its set energy. The light detector (22) monitors the surface quality of a previously crystallised portion (2). In accordance with the present invention, the light detector (22) is located at a position outside the specular reflection path (25) of the light returned by the surface area of the crystallised portion (2) and detects a threshold increase (D) in intensity ( $I_s$ ) of the light (26) being scattered by the surface area of the crystallised portion. This threshold increase (D) occurs when the energy ( $E_p$ ) of the beam (11) is increased sufficiently to cause the onset of surface roughening.

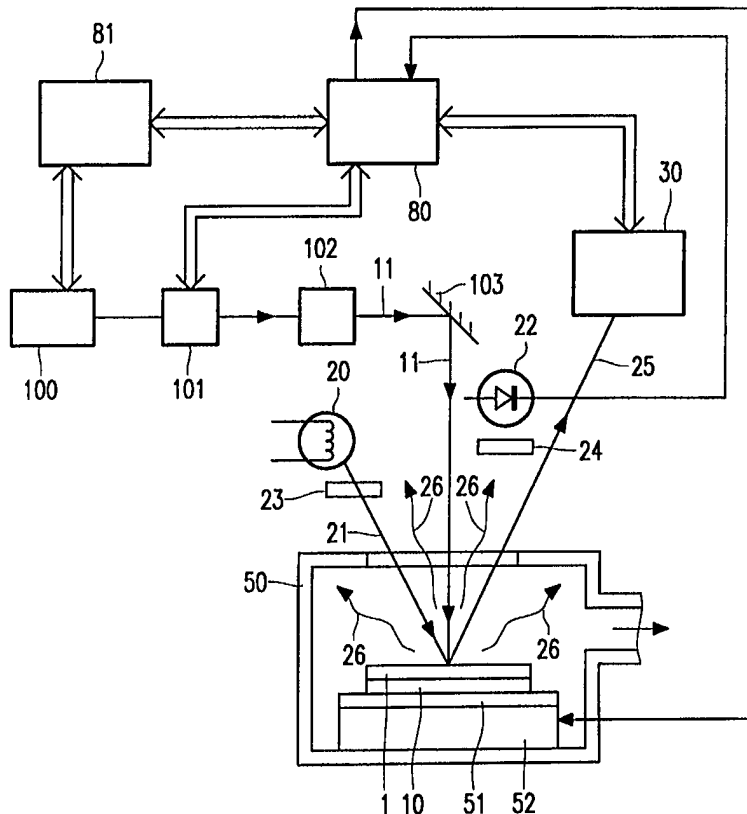

**FOR THE PURPOSES OF INFORMATION ONLY**

Codes used to identify States party to the PCT on the front pages of pamphlets publishing international applications under the PCT.

AL	Albania	ES	Spain	LS	Lesotho	SI	Slovenia
AM	Armenia	FI	Finland	LT	Lithuania	SK	Slovakia
AT	Austria	FR	France	LU	Luxembourg	SN	Senegal
AU	Australia	GA	Gabon	LV	Latvia	SZ	Swaziland
AZ	Azerbaijan	GB	United Kingdom	MC	Monaco	TD	Chad
BA	Bosnia and Herzegovina	GE	Georgia	MD	Republic of Moldova	TG	Togo
BB	Barbados	GH	Ghana	MG	Madagascar	TJ	Tajikistan
BE	Belgium	GN	Guinea	MK	The former Yugoslav Republic of Macedonia	TM	Turkmenistan
BF	Burkina Faso	GR	Greece	ML	Mali	TR	Turkey
BG	Bulgaria	HU	Hungary	MN	Mongolia	TT	Trinidad and Tobago
BJ	Benin	IE	Ireland	MR	Mauritania	UA	Ukraine
BR	Brazil	IL	Israel	MW	Malawi	UG	Uganda
BY	Belarus	IS	Iceland	MX	Mexico	US	United States of America
CA	Canada	IT	Italy	NE	Niger	UZ	Uzbekistan
CF	Central African Republic	JP	Japan	NL	Netherlands	VN	Viet Nam
CG	Congo	KE	Kenya	NO	Norway	YU	Yugoslavia
CH	Switzerland	KG	Kyrgyzstan	NZ	New Zealand	ZW	Zimbabwe
CI	Côte d'Ivoire	KP	Democratic People's Republic of Korea	PL	Poland		
CM	Cameroon	KR	Republic of Korea	PT	Portugal		
CN	China	KZ	Kazakstan	RO	Romania		
CU	Cuba	LC	Saint Lucia	RU	Russian Federation		
CZ	Czech Republic	LI	Liechtenstein	SD	Sudan		
DE	Germany	LK	Sri Lanka	SE	Sweden		
DK	Denmark	LR	Liberia	SG	Singapore		
EE	Estonia						

## DESCRIPTION

## ELECTRONIC DEVICE MANUFACTURE BY ENERGY BEAM CRYSTALLISATION

5           This invention relates to methods of manufacturing electronic devices comprising a thin-film circuit element, including the step of directing an energy beam at a surface of a semiconductor thin film to crystallise at least a portion of the thin film. The device may be a flat panel display (for example, a liquid crystal display), or a large area image sensor or several other types of large-  
10       area electronic device (for example, a thin-film data store or memory device). The invention also relates to apparatus for crystallising a portion of a semiconductor thin film.

          There is much interest in developing thin-film circuits with thin-film  
15       transistors (hereinafter termed TFTs) and/or other semiconductor circuit elements on insulating substrates for large-area electronics applications. These circuit elements fabricated with portions of an amorphous or polycrystalline semiconductor film may form the switching elements in a cell matrix, for example in a flat panel display as described in United States Patent  
20       Specification US-A-5,130,829 (our reference PHB 33646), the whole contents of which are hereby incorporated herein as reference material.

          Recent developments involve the fabrication and integration of thin-film circuits (usually with polycrystalline silicon) as, for example, integrated drive  
25       circuits for such a cell matrix. In order to increase the circuit speed, it is advantageous to use semiconductor material of good crystal quality and high mobility for thin-film islands of the TFTs of these circuits. It is known to deposit a semiconductor thin film of amorphous material or of low crystallinity material and then to form the material of high crystallinity in at least a device portion of this film by exposure to an energy beam from a laser.

30       United States Patent Specification US-A-5,372,836 discloses a method of manufacturing an electronic device comprising a thin-film circuit element,

which method includes the steps of:

(a) directing an energy beam at a surface area of a semiconductor thin film on a substrate to crystallise at least a portion of the thin film,

(b) monitoring the surface quality of the crystallised portion of the thin film by directing light at the surface area of the crystallised portion and by detecting with a light detector the light returned from the surface area, the light detector giving an output indicative of the monitored surface quality, and

(c) setting the energy of the beam in accordance with the output from the light detector to regulate the crystallisation of a device portion of a semiconductor thin film at which the beam is subsequently directed with its set energy.

The whole contents of US-A-5,372,836 are hereby incorporated herein as reference material.

In the method and apparatus described in US-A-5,372,836 the light detector is a spectroscope 16. The light source 17 for directing the light at the surface area of the crystallised thin-film portion has a wide wavelength band from 200nm to 500nm. The spectroscope 16 is located in the specular reflection path of the light returned by the surface area of the film. Sample outputs of the spectroscope 16 are depicted as graphs in Figures 18 to 21 of US-A-5,372,836, showing the bandgap spectral reflectance of a film in various crystallisation states. The spectral reflectance shown in these graphs are for a polycrystalline silicon film in an ideal state in Figure 18, for an amorphous silicon film in Figure 19, for an amorphous silicon film insufficiently transformed into polycrystalline silicon in Figure 20 due to an insufficient energy of the laser beam, and for a film damaged by an excessive energy of the laser beam in Figure 21.

In the method described in US-A-5,372,836, the semiconductor thin film is deposited on the substrate as hydrogenated amorphous silicon material by a plasma CVD (chemical vapour deposition) process. The device portion of the film is subjected to multiple exposures with the laser beam, the energy of the laser beam being progressively increased with each exposure. Initially, the

energy levels of the laser beam are set such that hydrogen is gradually discharged from the film without crystallising or damaging the film. The energy of the beam is finally set such that the film is transformed into a polycrystalline silicon material. The spectroscopy 16 provides a good source of information on the quality of the exposed film portion at the different stages.

As can be seen from Figures 18 to 20 of US-A-5,372,836, such an arrangement with specular reflection to a spectroscopy can provide a good indication of whether the film is still inadequately crystallised so enabling increased crystallisation of the film to be carried out by a further exposure with an increased beam energy. As shown in Figure 21, such an arrangement is also good for detecting when an excessive energy level has been used and has damaged the film. However, as described in column 13, lines 12 to 15, when the spectroscopic reflectance distribution shown in Figure 21 is detected, the sample is a defective one. It is then too late to remedy the situation, and the sample can only be discarded as being defective.

It is an aim of the present invention to provide a different light detection arrangement which provides an indication of a threshold change in monitored surface quality of the thin film prior to the occurrence of such damage, and so permits the use of a high beam energy in order to provide crystallised semiconductor material of good crystal quality and high mobility.

According to a first aspect of the present invention there is provided a method of manufacturing an electronic device comprising a thin-film circuit element, which method includes the steps of:

(a) directing an energy beam at a surface area of a semiconductor thin film on a substrate to crystallise at least a portion of the thin film,

(b) monitoring the surface quality of the crystallised portion of the thin film by directing light at the surface area of the crystallised portion and by detecting with a light detector the light returned by the surface area, the light detector giving an output indicative of the monitored surface quality, and

(c) setting the energy of the beam in accordance with the output from

the light detector to regulate the crystallisation of a device portion of a semiconductor thin film at which the beam is subsequently directed with its set energy,

5 characterised in that the light detector is located at a position outside the specular reflection path of the light returned by the surface area of the crystallised portion and detects a threshold increase in intensity of the light being scattered by the surface area of the crystallised portion, which threshold increase occurs when the energy of the beam is increased sufficiently to cause an onset of surface roughening, and in that, when crystallising the device  
10 portion for the thin-film circuit element during the step (c), the energy of the beam is set to a value as determined by the detection of said threshold increase.

The present invention utilises a discovery by the present inventors that, as the beam energy is increased, there is an onset of surface roughening which  
15 occurs before the thin film is damaged by an excessive energy level. The onset of surface roughening seems to relate to a sudden appearance of a spatially periodic perturbation (ripples) in the crystallised semiconductor material as described in the article "Surface roughness effects in laser crystallised polycrystalline silicon" by the present inventors, published in  
20 Applied Physics Letters, Vol 66, No 16, 17 April 1995, pages 2060 to 2062, the whole contents of which are incorporated herein as reference material. this onset of surface roughening precedes an increase in grain size which occurs as melt-through of the film is approached, i.e when the absorbed energy of the beam in the film is sufficient to form a molten zone which reaches through most  
25 of the thickness of the film to the substrate. The present inventors find that this particular onset of surface roughening cannot be detected with adequate sensitivity using specularly reflected light. However, an arrangement in accordance with the present invention which detects light scattered by the crystallised surface area is able to detect the particular onset of surface  
30 roughening and has sufficient sensitivity for reliable and accurate detection in a manufacturing situation. Thus, the present invention permits detection of this

onset of surface roughening to be used to set the beam energy for a large-grain high-mobility crystal state of the thin film.

Thus, the present invention permits the energy of the beam to be increased to a value (as reliably determined by the detection of this threshold increase in scattered light) for producing large-grain good-quality high-mobility crystal material, below an excessive energy level associated with damage to the film. Good quality crystallised film portions with electron mobilities in excess of  $100\text{cm}^2.\text{V}^{-1}.\text{s}^{-1}$  can be reliably obtained in accordance with the present invention. Generally speaking, the optimum beam energy for maximum film mobility does not coincide with the energy at which the onset of this surface roughening occurs as detected by said threshold increase in scattered light, but occurs at a slightly higher energy. Thus, for maximum film mobility, the energy of the beam is set to a value of  $(E + dE)$ , where  $E$  is the energy at which this particular onset of surface roughening is detected and  $dE$  is a small incremental increase (for example 10 to 60  $\text{mJ}.\text{cm}^{-2}$ ) for typical thicknesses of the thin film required for most circuit elements of large area electronic devices. The value of  $dE$  increases with increasing values of  $E$ , as described hereinafter.

In a batch manufacturing process where a batch of thin films on substrates are crystallised with the energy beam, the energy of the beam may be set to an operational value when processing a first substrate in the batch, and this operational value may then be used for subsequent substrates in the batch. However, it is advantageous to monitor the surface quality and so to regulate the energy value of the beam for each substrate in the batch. Thus, the present inventors find that the threshold increase in scattered light intensity occurs at an energy value  $E$  which is dependent on the thickness of the thin film.

The present invention permits the energy value of the beam to be set in accordance with the actual thickness of the film of any given sample, so that the energy value can be set for each sample. Thus, the portion crystallised in step (a) for monitoring in step (b) may be a part of the same semiconductor thin film as the device portion subsequently crystallised with the beam of set

energy in step (c). The device portion of the thin film may be a separate area from a test surface area of the film where the monitoring of step (b) is carried out. Thus, a method in accordance with the present invention may be further characterised by the steps of directing the energy beam at a test surface area of the semiconductor film in step (a), setting the energy of the beam to the set value by monitoring the quality of the crystallised test surface area by means of the scattered light in step (b), and directing the energy beam with the set value of energy at a different surface area of the same semiconductor thin film to crystallise the device portion for the thin-film circuit element. It is convenient to provide the test area as a peripheral area of the semiconductor thin film. Thus, the energy beam may first be scanned along the test area to regulate its energy, after which it may be scanned along the device area with the set value.

According to a second aspect of the present invention there is provided apparatus for crystallising a portion of a semiconductor thin film on a substrate comprising

a laser for generating an energy beam to crystallise the portion of the thin film,

a processing cell containing a support for mounting the substrate,  
an optical system between the laser and the processing cell to direct the beam from the laser at a surface area of the thin film when the substrate is mounted in the processing cell,

adaptor means for changing the energy of the beam incident on the film,  
a light source for directing light at the surface area of the crystallised portion of the thin film, and

a light detector for detecting the light returned by the surface area, the light detector giving an output indicative of the surface quality,

characterised in that the light detector is located at a position outside the specular reflection path of the light returned by the surface area of the crystallised portion and has sufficient sensitivity to detect a threshold increase in intensity of the light being scattered by the surface area of the crystallised portion, which threshold increase occurs when the energy of the beam is

increased sufficiently to cause the onset of surface roughening, and control means take an input from the output of the light detector and provide an output to the adaptor means for setting the energy of the beam to a value as determined by the detection of said threshold increase.

5 Preferably the energy of the beam is adjusted to the set value by means of an attenuator or other optical element which is located in the path of the beam, and which forms part of the optical system between the laser and the processing cell. Using an optical element as the adaptor means is more preferable than adjusting the electrical power supply to the laser, because  
10 adjustment of the laser itself via the power supply during operation tends to cause instability.

The scattered light which is detected may be directed at the surface area of the crystallised portion from a light source independent of the beam used for crystallising the thin-film portion. However, the beam used for crystallising the  
15 thin-film portion may be generated by a laser, and this laser and its generated beam may also provide the light which is scattered to the light detector for monitoring the surface quality in step (b) of the method.

These and other features in accordance with the present invention, and  
20 their advantages, are illustrated specifically in embodiments of the invention now to be described, by way of example, with reference to the accompanying diagrammatic drawings, in which:

Figure 1 is a schematic of laser apparatus in accordance with the present invention and suitable for use in a manufacturing method also in  
25 accordance with the present invention;

Figure 2 is a schematic cross-sectional view of a semiconductor thin film on a substrate during the manufacture of an electronic device in accordance with the present invention;

Figure 3 is a plan view of different areas of the semiconductor film of the  
30 Figure 2;

Figure 4 is a cross-section view of one example of a TFT fabricated with

a film portion crystallised in a method in accordance with the invention;

Figure 5 is a graph of electron mobility ( $\mu_n$ ) in  $\text{cm}^2 \cdot \text{V}^{-1} \cdot \text{s}^{-1}$  in a crystallised film portion, as a function of peak laser energy ( $E_p$ ) in  $\text{mJ} \cdot \text{cm}^{-2}$  per pulse for different film thicknesses ( $t_{\text{Si}}$ ) in nm; and

5 Figure 6 is a graph of scattered light intensity  $I_s$  in arbitrary units as a function of peak laser energy ( $E_p$ ) in  $\text{mJ} \cdot \text{cm}^{-2}$  per pulse for a film thickness  $t_{\text{Si}}$  of 40nm.

It should be noted that Figures 1 to 4 are diagrammatic and not drawn to scale. Relative dimensions and proportions of parts of these Figures have  
10 been shown exaggerated or reduced in size, for the sake of clarity and convenience in the drawings. The same reference signs are generally used to refer to corresponding or similar features in different embodiments.

As illustrated by examples in Figures 1 to 3, the present invention  
15 provides both a method of manufacturing a large-area electronic device (for example a flat panel display similar to that disclosed in US-A-5,130,829) and also apparatus for crystallising a portion of a semiconductor thin film 1 in such a method.

The method includes the steps of:

20 (a) directing an energy beam 11 at a surface area of a semiconductor thin film 1 on a substrate 10 to crystallise at least a portion 2 of the thin film 1 (Figure 2),

(b) monitoring the surface quality of the crystallised portion 2 of the thin film 1 by directing light 21 at the surface area of the crystallised portion 2 and  
25 by detecting with a light detector 22 the light returned by the surface area, the light detector 22 giving an output indicative of the monitored surface quality (Figures 1 and 2), and

(c) setting the energy of the beam 11 in accordance with the output from the light detector 22 to regulate the crystallisation of a device portion 3,4  
30 and/or 5 of a semiconductor thin film 1 at which the beam 11 is subsequently directed with its set energy (Figures 1 and 3).

In accordance with the present invention, the light detector 22 is located at a position outside the specular reflection path 25 of the light returned by the surface area of the crystallised portion and detects a threshold increase (D in Figure 6) in intensity  $I_s$  of the light 26 being scattered by the surface area of the crystallised portion, which threshold increase D occurs when the energy  $E_p$  of the beam 11 is increased sufficiently to cause the onset of surface roughening, and in that, when crystallising the device portion 3,4 and/or 5 for a thin-film circuit element (for example a polycrystalline silicon TFT) during the step (c), the energy of the beam 11 is set to a value as determined by the detection of said threshold increase D.

The apparatus, as illustrated in Figure 1 comprises a laser 100 for generating the energy beam 11 to crystallise the portion of the thin film 1; a processing cell 50 containing a support 51 for mounting the substrate 10; an optical system 101 to 103 between the laser 100 and the processing cell 50 to direct the beam 11 from the laser 100 at a surface area of the thin film 1 when the substrate 10 is mounted in the processing cell 50; and adaptor means 81,101 for changing the energy of the beam 11 incident on the film 1; a light source 20 for directing light 21 at the surface area of the crystallised portion 2 of the thin film 1, and a light detector 20 for detecting the light returned by the surface area, the light detector 20 giving an output indicative of the surface quality.

In accordance with the present invention, the light detector 22 is located at a position outside the specular reflection path 25 of the light returned by the surface area of the crystallised portion 2 and has sufficient sensitivity to detect a threshold increase D in intensity  $I_s$  of the light 26 being scattered by the surface area of the crystallised portion, which threshold increase D occurs when the energy of the beam 11 is increased sufficiently to cause the onset of surface roughening, and control means 80 couple the light detector 22 to the adaptor means 81,101 to take an input from the output of the light detector 22 and to provide an output control signal to the adaptor means 81,101 for setting the energy of the beam 11 to a value as determined by the detection of said

threshold increase D.

Preferably a pulsed laser beam 11 of an ultraviolet wavelength is used, generated by an excimer laser 100. A laser beam 11 of ultraviolet wavelength has the known advantage of permitting control of its absorption depth in the semiconductor material of the film 1. Useful laser wavelengths are 248nm from  
5 a KrF laser, or a wavelength of 308nm from an XeCl laser, or a wavelength of 351nm from an XeF laser.

Apart from the inclusion and use of the scattered light detector 22, the laser apparatus of Figure 1 may be similar to that described in US-A-5,372,836  
10 and/or in the Journal article "Beam Shape Effects with Excimer Laser Crystallisation of Plasma Enhanced and Low Pressure Chemical Vapour Deposited Amorphous Silicon" by S D Brotherton, D J McCulloch et al in Solid State Phenomena, Vols 37 to 38 (1984), pages 299 to 304. The whole of this Solid State Phenomena article are hereby incorporated herein as reference  
15 material.

Thus, the laser apparatus of Figure 1 comprises an electrical power supply 81 for the laser 100. The power supply 81 is regulated by a computer control system 80. The computer control system 80 also regulates the movement of an X-Y table 52 for scanning the laser beam 11 along the surface  
20 of the thin film 1. In the arrangement illustrated by way of example in Figure 1, the X-Y table 52 moves the substrate 10, although an arrangement as illustrated in US-A-5,372,836 may be used in which an X-Y table moves an optical element to move the laser beam 11. In the example illustrated in Figure 1, the substrate support 51 is a susceptor which is mounted on the X-Y table  
25 52. The position of the X-Y table 52 is controlled by an input signal from the computer control system 80. The processing cell 50 may be, for example, a vacuum chamber.

The optical system 101 to 103 between the laser 100 and the processing cell 50 may comprise an attenuator 101, an homogeniser 102 for controlling the  
30 beam shape, and one or more total-reflection mirrors 103 for deflecting the beam 11. Typically the optical system 101 to 103 also comprises other optical

elements, for example one or more apertures and lenses. The attenuator 101 controls the energy of the beam 11 transmitted from the laser 100 to the processing cell 50. This attenuator 101 may be of known form, for example one or more tilting transmission plates, the angle of which is varied to vary the transmitted energy level. The angle of the plates is set in known manner by  
5 an output signal from the computer control system 80.

The apparatus may comprise a spectroscope 30 for generating band-gap spectroscopic reflectance distributions as illustrated in Figures 18 to 21 of US-A-5,372,836. However, most importantly, the apparatus comprises the  
10 scattered light detector 22 which is provided and used in accordance with the present invention. Thus, the light detector 22 provides its output to the computer control system 80. The computer control system 80 then sets the energy of the beam 11 to a value  $(E + dE)$  as determined by the detection of a threshold increase in the scattered light 26. This change in the energy of the  
15 beam 11 may be effected via an output signal from the computer control system 80 to the electrical power supply 81 of the laser 100. However, it is preferable not to disturb the electrical supply to the laser 100 during its operation. Therefore, it is preferable to change the energy of the beam 11 by the computer control system 80 providing an output to the attenuator 101.

20 The light 21 which is directed at the surface of the crystallised thin-film portion 2 may be from a light source 20 independent of the beam 11 used for crystallising the thin-film portion 2. The wavelength of the scattered light 26 may therefore be made quite different from that of the laser beam 11, so that the light detector 22 can readily respond to the scattered light 26 from source  
25 20, in distinction from any returning light from the laser beam 11. The light 21,26 may be of an ultraviolet wavelength, for example at about 325nm when the laser beam 11 is at 248nm. A filter and shutter arrangement 23 and 24 may be present in front of each of the light source 20 and light detector 22 to determine the wavelength and timing of the light transmission from the source  
30 20 to the detector 22. The scattered light detector 22 may be of any convenient type, for example a photodiode.

However, instead of using a separate light source 20 with the detector 22, the laser beam 11 used for crystallising the thin-film portion 2 may provide the light 26 which is scattered to the light detector 22 for monitoring the surface quality. Beam 11 may have a spatial energy distribution (for example a Gaussian distribution in the scan direction) comprising a peak energy rising from a leading edge of increasing energy and falling off in a trailing edge of reducing energy. The energy regulation achieved in accordance with the present invention may be such that the peak energy value is just sufficient to achieve melt-through of the film thickness; in this case, the trailing edge of reducing energy allows the crystallisation of smaller grains as nuclei for large grain growth in the film 1, which may be even more optimum for providing high electron field-effect mobilities. Furthermore, the leading and trailing edges permit the laser beam 11 to be used in monitoring the crystallisation quality of the cooling film 1 after melt-through. Thus, with a pulsed laser beam 11, the leading edge of the next pulse provides the incident light which is scattered as light 26 to the detector 22 from the surface of the cooling film portion 2 which has crystallised after melt-through by the previous pulse. In this case, for example, the beam 11 and hence also the scattered light 26 may have a wavelength of 308nm. The increasing energy in the leading edge of such a pulse is also advantageous in achieving a gradual release of hydrogen in the laser crystallisation of a hydrogen-rich PECVD a-Si:H film 1 as described in the said Solid State Phenomena article. However, a shaped beam having such a spatial energy distribution may also be used to crystallise silicon films having substantially no damaging hydrogen content.

The present invention may be used to optimise crystal grain size and field-effect mobility in polycrystalline silicon films for thin-film circuit element fabrication in known types of large-area electronic device. By way of example, the experimental results illustrated in Figures 5 and 6 were obtained by fabricating so-called "top-gate co-planar polysilicon TFTs" similar to the TFT shown in Figure 6 of US-A-5,130,829. Such a top-gate co-planar polysilicon TFT is illustrated in Figure 4. The gate electrode 42 is present on a gate

dielectric film 41 on a crystallised portion of the thin-film 1 which provides the channel region of the TFT. Doped source and drain regions 43 and 44 are formed in the film 1 and contacted by metal film electrodes 45 and 46. Such TFTs may form the switching elements of an array of a display matrix as described in US-A-5,130,829. However, they may also form circuit elements in row and column driver circuits integrated on the same substrate 10 as the display array.

By way of example, Figure 3 shows in plan view a thin film 1 on a substrate 10 which is subsequently divided into four display components by scribing along the lines M-M, M'-M', and N-N. Each display component comprises an array area 5 bordered on two sides by a row driver circuit area 4 and a column driver circuit area 3. The whole of the thin film 1 (i.e areas 3, 4 and 5) may be crystallised with the laser beam 11. However, if desired, the array area 5 may be retained as amorphous silicon material and only the column and row driver circuit areas 3 and 4 may be crystallised with the beam 11. The arrangement illustrated in Figure 3 also comprises a test surface area 2 which is a peripheral area of the semiconductor thin film 1 on the substrate 10. This test area 2 is part of the same semiconductor thin film 1 as the device portions 3, 4 and 5. In this case, the method of manufacture includes the steps of directing the beam 11 at the test area 2 in step (a), regulating the energy of the beam 11 to the set value by monitoring the quality of the crystallised test surface area 2 by means of the scattered light 26 in step (b), and then directing the beam 11 with the set value of energy at the different surface areas 3, 4 and/or 5 to crystallise these different portions for the thin-film circuit elements of the display components.

The present invention may be used to crystallise semiconductor thin films 1 having a hydrogen content. However, as described in the Applied Physics Letters article and the Solid State Phenomena article, the release of hydrogen from the film when scanned with a laser beam can result in significant surface roughening. In order to illustrate the different surface roughening mechanism which is utilised in accordance with the present invention, it is

preferable to avoid any confusion with surface roughening caused by hydrogen release. For this reason, the experimental results given in Figures 5 and 6 are for a semiconductor thin film of a silicon material which has substantially no hydrogen content at least when crystallising the device portion 3,4,5 of the thin film 1 for the thin-film circuit elements. The film 1 may be deposited by PECVD (plasma enhanced chemical vapour deposition) with a hydrogen content which may be slowly released by gradual heating before carrying out any laser crystallisation treatment. However, the thin film 1 may be deposited by LPCVD (low pressure chemical vapour deposition) with only a very low hydrogen content. In the case of Figures 5 and 6, the pre-cursor films 1 crystallised by the beam 11 were deposited as amorphous silicon LPCVD layers at 540°C. The substrate 10 comprised a glass plate 10b capped with an insulating layer 10a of silicon dioxide. The silicon film 1 was deposited on this insulating layer 10a. For the results of Figures 5 and 6, a gate dielectric 41 of silicon dioxide was deposited to a thickness of 140nm in a PECVD reactor at 300°C. A TFT having an aluminium gate 42 and the co-planar configuration illustrated in Figure 4 was formed with the crystallised film 1. The silicon film 1 is patterned by etching into individual islands for the individual TFTs and any other thin-film circuit elements of the device.

The peak energy  $E_p$  given in Figures 5 and 6 is the peak energy occurring within a semi-Gaussian distribution for the beam 11, for example as described in the Solid State Phenomena article.  $E_p$  is the peak energy density in  $\text{mJ.cm}^{-2}$  for each pulse of the beam 11. Typically the pulse duration is about 30ns (nanoseconds). The device portions of the film 1 were subjected to approximately 140 pulses to obtain the mobility results shown in Figure 5.

Figure 5 shows the variation of electron field effect mobility ( $\mu_n$ ) with both the incident peak energy ( $E_p$ ) in each laser pulse and with the thickness ( $t_{Si}$ ) of the LPCVD pre-cursor film 1. There is a clear pattern to these mobility results. In region A there is an initial increase in mobility (and its saturation in region B at 40 to 60 $\text{cm}^2.\text{V}^{-1}.\text{S}^{-1}$ ) which arises from the primary conversion of the surface of the amorphous silicon film 1 to polycrystalline silicon. Under these

conditions, the crystallised film 1 appears to be stratified with an upper layer of grains about 100nm wide on a finer grain background. In region C there is a second increase in mobility which arises as the melt-through condition is approached. The energies required for melt-through are strongly dependent on the film thickness  $t_{Si}$ . Over the range of thicknesses shown, the melt-through threshold voltage varied approximately linearly with film thickness  $t_{Si}$ . TEM (transmission electron microscope) investigation of these films in the region C has shown both an increase of 2 to 3 times in grain size and an absence of stratification in samples having the peak mobility. The peak mobility was about  $175\text{cm}^2.\text{V}^{-1}.\text{s}^{-1}$  for the 40nm thick film 1, and in excess of  $200\text{cm}^2.\text{V}^{-1}.\text{s}^{-1}$  for the 80nm thick film 1. The mobility is observed to fall off after these peak values, apparently due to the onset of crystallographic damage in the film as a result of an excessive energy of the beam 11.

The transition from saturation region B to the second increasing region C is well defined for the films 1 with thicknesses  $t_{Si}$  of 80nm and 145nm. This transition from regions B to C is not so clear in Figure 5 for the film 1 having a thickness of 40nm. However, the occurrence of a related transition can be seen quite clearly by examining the scattered light 26 from the 40nm thick film 1, as illustrated in Figure 6. Thus, Figure 6 shows that there is an order of magnitude increase D in the scattered light 26 as a characteristic surface roughening of the film occurs before melt-through. This threshold increase D in scattered light 26 is easily detected with the light detector 22. The results shown in Figure 6 were for light 21,26 of 325nm wavelength. A pulsed laser beam of 248nm was used for the crystallisation of the film 1.

This onset of surface roughening seems to be related to the appearance of a periodic spatially varying roughness as described and shown in the said Applied Physics Letters article. It should be noted that there is a reduction of only a few percent in the reflected light 25 from the film surface as this roughening occurs. This small change in surface reflectance provides inadequate sensitivity for reliably monitoring the occurrence of this onset. By contrast therewith, there is an order of magnitude increase in the scattered light

26 as this onset occurs.

It should also be noted that the energy  $E$  at which the onset of surface roughening occurs (as detected by this threshold increase  $D$  in scattered light 26) is at a lower value than the optimum beam energy for maximum film mobility as shown in Figure 5. Generally speaking, for a semiconductor thin film of silicon having a thickness in the range of 20nm to 60nm, this optimum beam energy is within  $60\text{mJ}\cdot\text{cm}^{-2}$  of the value  $E$  causing the onset of surface roughening as detected by the threshold increase  $D$  in intensity of the scattered light 26. Thus, for example, for the 40nm thick film 1 the threshold increase  $D$  in scattered light intensity as shown in Figure 6 occurs between 225 and 240 $\text{mJ}\cdot\text{cm}^{-2}$ . The optimum beam energy for maximum field-effect electron mobility as illustrated in Figure 5 occurs at about  $270\text{mJ}\cdot\text{cm}^{-2}$ . Therefore, the energy of the beam 11 used for crystallisation of device portions 3,4, and/or 5 of the film 1 in step (c) is preferably set to a regulated value which is about 25 $\text{mJ}\cdot\text{cm}^{-2}$  higher than the energy threshold indicated in Figure 6. Thus, for maximum film mobility, the energy of the beam 11 is set to a value of  $(E + dE)$ , where  $E$  is the energy at which the particular onset of surface roughening is detected by the scattered light detector 22 as illustrated in Figure 6, and where  $dE$  is an incremental increase which is found by the present inventors to be dependent on the thickness  $t_{\text{Si}}$  of the thin film 1 and which is thus also related to the energy value  $E$ . For film thicknesses  $t_{\text{Si}}$  of less than 40nm the set value  $(E + dE)$  converges rapidly towards  $E$ , whereas for thicker films 1 the incremental increase  $dE$  increases strongly as the thickness  $t_{\text{Si}}$  increases. Thus, the incremental increase  $dE$  is nearly  $150\text{mJ}\cdot\text{cm}^{-2}$  for a film thickness of  $t_{\text{Si}}$  of 80nm. The films 1 required for most TFTs and other thin-film circuit elements of large-area electronic devices today have film thicknesses of less than 50nm, and the general trend is towards even thinner films, for example 40nm, 30nm and less. The value of the incremental increase  $dE$  (to be added to the scattered-light monitored value  $E$  so as to set the beam energy for optimum crystal growth) can be stored in a look-up table of the computer control system 80.

From reading the present disclosure, many modifications and variations will be apparent to persons skilled in the art. Such modifications and variations may involve equivalent features and other features which are already known in the art and which may be used instead of or in addition to features already disclosed herein. Although claims have been formulated in this Application to particular combinations of features, it should be understood that the scope of the disclosure of the present application includes any and every novel feature or any novel combination of features disclosed herein either explicitly or implicitly and any generalisation thereof, whether or not it relates to the same invention as presently claimed in any Claim and whether or not it mitigates any or all of the same technical problems as does the present invention. The Applicants hereby give notice that new claims may be formulated to such features and/or combinations of such features during prosecution of the present application or of any further application derived therefrom.

## CLAIMS

1. A method of manufacturing an electronic device comprising a thin-film circuit element, which method includes the steps of:

5 (a) directing an energy beam at a surface area of a semiconductor thin film on a substrate to crystallise at least a portion of the thin film,

(b) monitoring the surface quality of the crystallised portion of the thin film by directing light at the surface area of the crystallised portion and by detecting with a light detector the light returned by the surface area, the light  
10 detector giving an output indicative of the monitored surface quality, and

(c) setting the energy of the beam in accordance with the output from the light detector to regulate the crystallisation of a device portion of a semiconductor thin film at which the beam is subsequently directed with its set  
energy,

15 characterised in that the light detector is located at a position outside the specular reflection path of the light returned by the surface area of the crystallised portion and detects a threshold increase in intensity of the light being scattered by the surface area of the crystallised portion, which threshold  
increase occurs when the energy of the beam is increased sufficiently to cause  
20 an onset of surface roughening, and in that, when crystallising the device portion for the thin-film circuit element during the step (c), the energy of the beam is set to a value as determined by the detection of said threshold increase.

25 2. A method as claimed in Claim 1, further characterised in that the portion crystallised in step (a) is a part of the same semiconductor thin film as the device portion subsequently crystallised with the beam of set energy in step (c).

30 3. A method as claimed in Claim 2, further characterised by the steps of directing the energy beam at a test surface area of the semiconductor

thin film in step (a), changing the energy of the beam to the set value by monitoring the quality of the crystallised test surface area by means of the scattered light in step (b), and directing the energy beam with the set value of energy at a different surface area of the semiconductor thin film to crystallise the device portion for the thin-film circuit element.

4. A method as claimed in Claim 3, further characterised in that the test surface area is a peripheral area of the semiconductor thin film.

5. A method as claimed in any one of Claims 1 or 2 or 3 or 4, further characterised in that the light which is directed at the surface area of the crystallised portion is from a light source independent of the beam used for crystallising the thin-film portion.

6. A method as claimed in any one of Claims 1 or 2 or 3 or 4, further characterised in that the beam used for crystallising the portion of the thin film is from a laser and provides also the light which is scattered to the light detector for monitoring the surface quality in step (b).

7. A method as claimed in any one of Claims 1 to 6, further characterised in that the semiconductor thin film is of silicon having a thickness in the range of 20nm to 60nm, and in that the set value of the energy of the beam used for crystallisation in step (c) is within  $60\text{mJ}\cdot\text{cm}^{-2}$  of the value causing the onset of surface roughening as detected by the threshold increase in intensity of the light being scattered by the surface area of the crystallised portion.

8. A method as claimed in any one of Claims 1 to 7, further characterised in that the semiconductor thin film is of a silicon material which has substantially no damaging hydrogen content at least when crystallising the device portion of the thin film for the thin-film circuit element during the step (c).

9. Apparatus for crystallising a portion of a semiconductor thin film on a substrate comprising

a laser for generating an energy beam to crystallise the portion of the thin film,

5 a processing cell containing a support for mounting the substrate,  
an optical system between the laser and the processing cell to direct the beam from the laser at a surface area of the thin film when the substrate is mounted in the processing cell,

adaptor means for changing the energy of the beam incident on the film,

10 a light source for directing light at the surface area of the crystallised portion of the thin film, and

a light detector for detecting the light returned by the surface area, the light detector giving an output indicative of the surface quality,

15 characterised in that the light detector is located at a position outside the specular reflection path of the light returned by the surface area of the crystallised portion and has sufficient sensitivity to detect a threshold increase in intensity of the light being scattered by the surface area of the crystallised portion, which threshold increase occurs when the energy of the beam is increased sufficiently to cause the onset of surface roughening, and control  
20 means take an input from the output of the light detector and provide an output to the adaptor means for setting the energy of the beam to a value as determined by the detection of said threshold increase.

10. Apparatus as claimed in Claim 9, further characterised in that the  
25 adaptor means is an attenuator which is located in the path of the beam, and which forms part of the optical system between the laser and the processing cell.

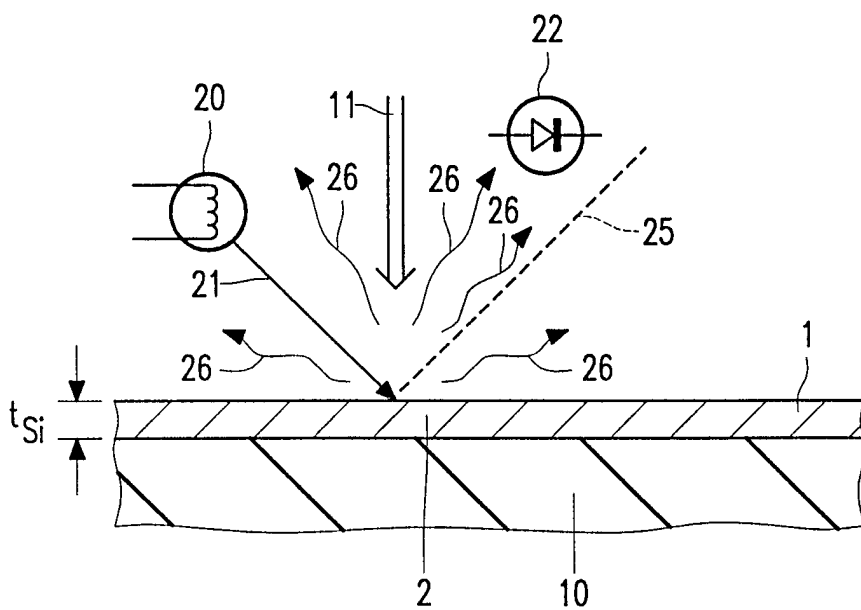
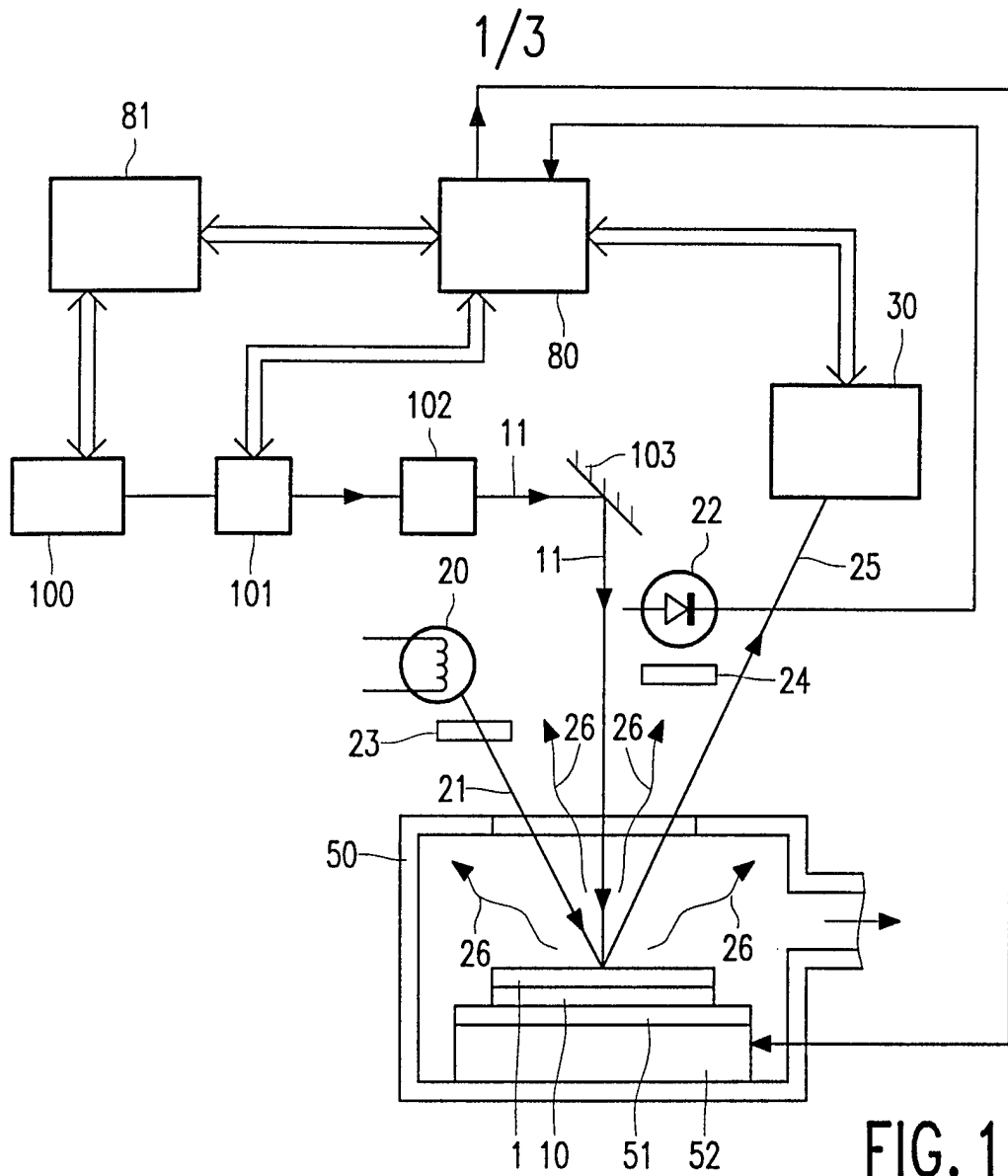

2/3

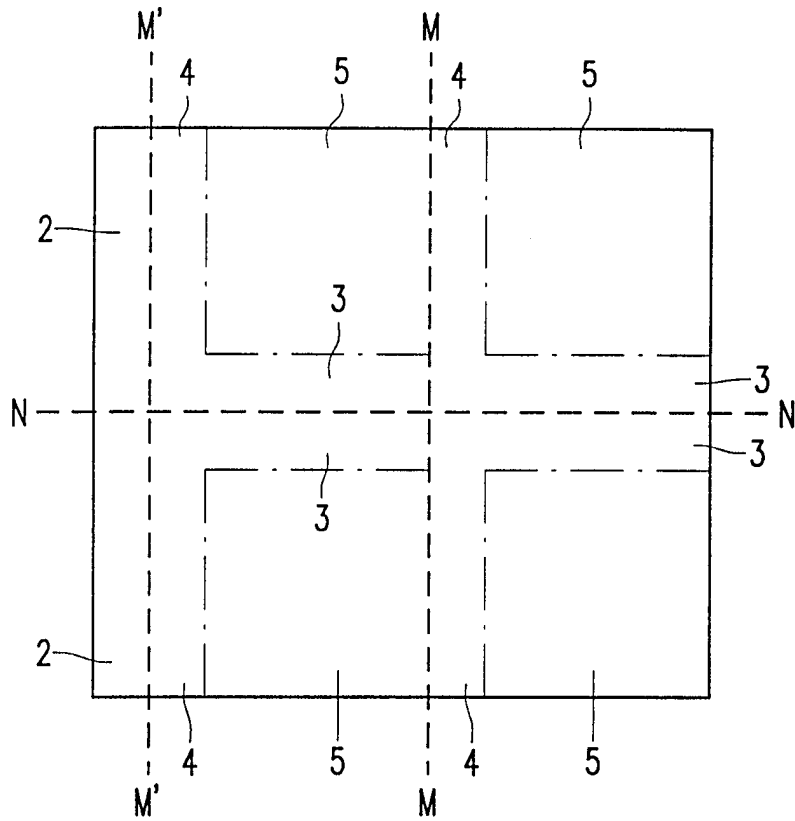

FIG. 3

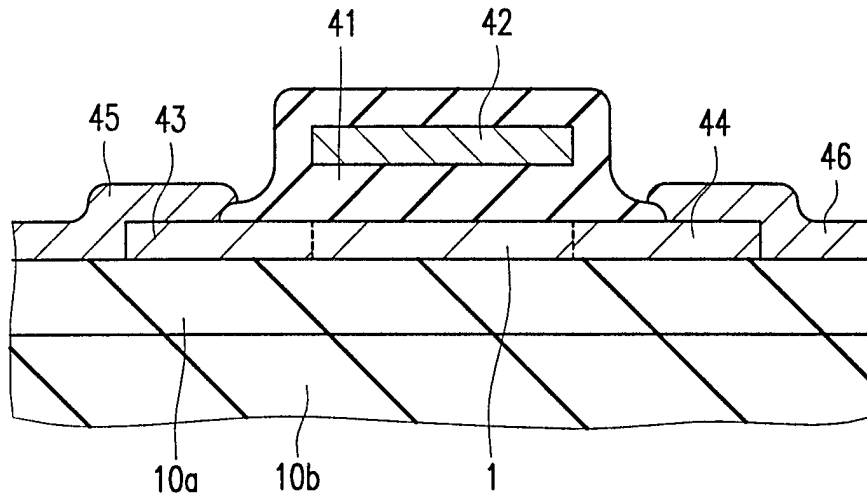

FIG. 4

3/3

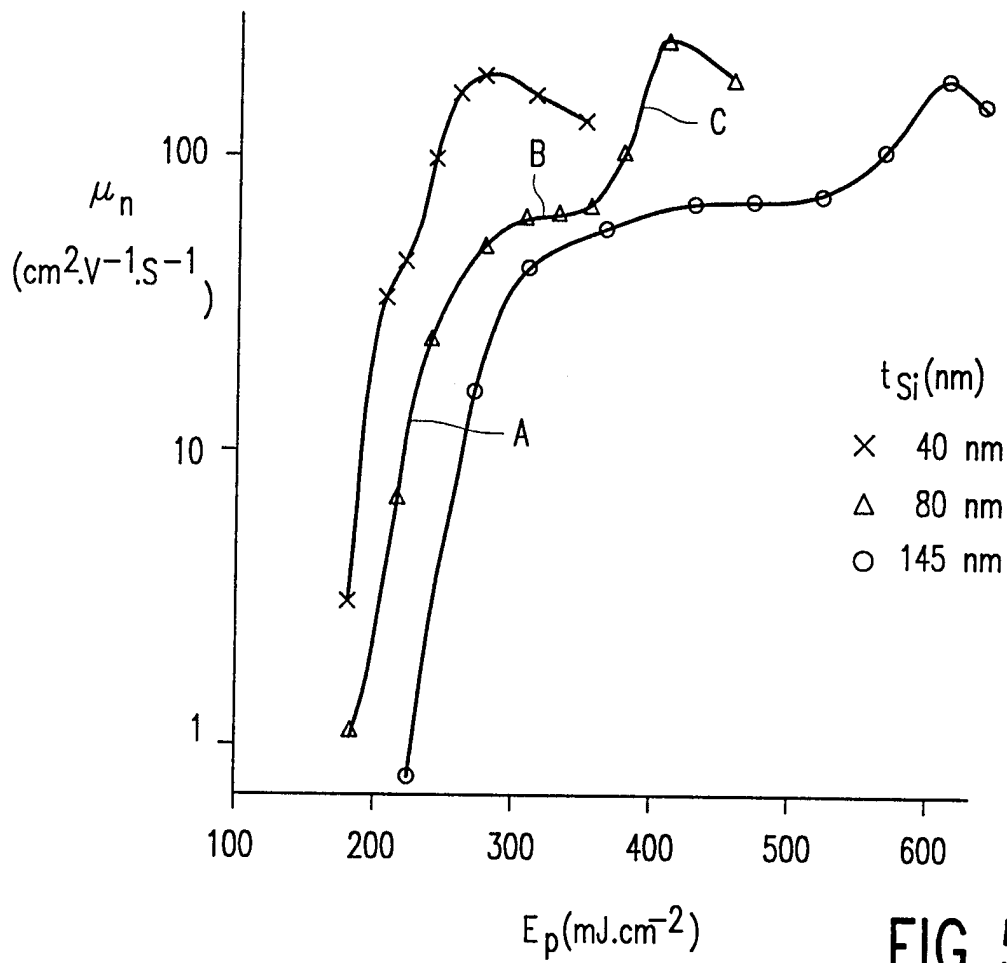

FIG. 5

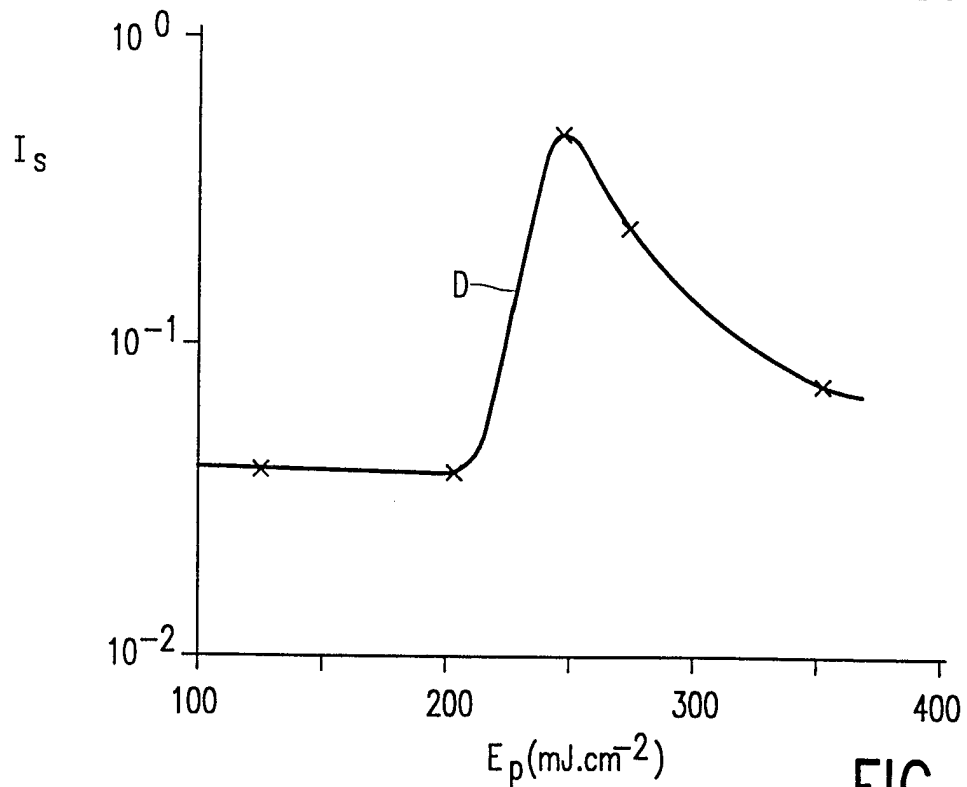

FIG. 6

## INTERNATIONAL SEARCH REPORT

International application No.

PCT/IB 97/01186

## A. CLASSIFICATION OF SUBJECT MATTER

IPC6: H01L 21/302, H01L 21/263

According to International Patent Classification (IPC) or to both national classification and IPC

## B. FIELDS SEARCHED

Minimum documentation searched (classification system followed by classification symbols)

IPC6: H01L

Documentation searched other than minimum documentation to the extent that such documents are included in the fields searched

SE,DK,FI,NO classes as above

Electronic data base consulted during the international search (name of data base and, where practicable, search terms used)

DIALOG. 2,350,434

## C. DOCUMENTS CONSIDERED TO BE RELEVANT

Category*	Citation of document, with indication, where appropriate, of the relevant passages	Relevant to claim No.
A	Solid State Phenomena, Volume 37-38, 1994, (Switzerland), S.D. Brotherton et al, "BEAM SHAPE EFFECTS WITH EXCIMER LASER CRYSTALLISATION OF PLASMA ENHANCED AND LOW PRESSURE CHEMICAL VAPOR DEPOSITED AMORPHOUS SILICON" page 299 - page 304 --	1-10
A	US 5372836 A (ISSEI IMAHASHI ET AL), 13 December 1994 (13.12.94), figure 5, abstract --	1-10
A	EP 0367624 A2 (LASA INDUSTRIES, INC.), 9 May 1990 (09.05.90), figure 1, abstract --	1-10

 Further documents are listed in the continuation of Box C. See patent family annex.

\* Special categories of cited documents:

"A" document defining the general state of the art which is not considered to be of particular relevance

"E" earlier document but published on or after the international filing date

"L" document which may throw doubts on priority claim(s) or which is cited to establish the publication date of another citation or other special reason (as specified)

"O" document referring to an oral disclosure, use, exhibition or other means

"P" document published prior to the international filing date but later than the priority date claimed

"T" later document published after the international filing date or priority date and not in conflict with the application but cited to understand the principle or theory underlying the invention

"X" document of particular relevance: the claimed invention cannot be considered novel or cannot be considered to involve an inventive step when the document is taken alone

"Y" document of particular relevance: the claimed invention cannot be considered to involve an inventive step when the document is combined with one or more other such documents, such combination being obvious to a person skilled in the art

"&amp;" document member of the same patent family

Date of the actual completion of the international search

8 April 1998

Date of mailing of the international search report

14 -04- 1998

Name and mailing address of the ISA/  
Swedish Patent Office  
Box 5055, S-102 42 STOCKHOLM  
Facsimile No. +46 8 666 02 86

Authorized officer

Patrik Rydman  
Telephone No. +46 8 782 25 00

## INTERNATIONAL SEARCH REPORT

International application No.

PCT/IB 97/01186

C (Continuation). DOCUMENTS CONSIDERED TO BE RELEVANT		
Category*	Citation of document, with indication, where appropriate, of the relevant passages	Relevant to claim No.
A	US 4309225 A (JOHN C.C. FAN ET AL), 5 January 1982 (05.01.82), column 2, line 50 - column 3, line 30, figures 1,7  ---	1-10
A	US 4155779 A (DAVID H. AUSTON ET AL), 22 May 1979 (22.05.79), column 1, line 45 - line 57, figures 1, 2  -----	1-10

# INTERNATIONAL SEARCH REPORT

Information on patent family members

02/03/98

International application No.

PCT/IB 97/01186

Patent document cited in search report	Publication date	Patent family member(s)	Publication date
US 5372836 A	13/12/94	JP 5275336 A	22/10/93
		CN 1088002 A	15/06/94
		EP 0598394 A	25/05/94
		JP 6224276 A	12/08/94
		JP 8129189 A	21/05/96
		US 5413958 A	09/05/95
		US 5529630 A	25/06/96
EP 0367624 A2	09/05/90	JP 2244779 A	28/09/90
		US 4865683 A	12/09/89
US 4309225 A	05/01/82	EP 0035561 A,B	16/09/81
		JP 56501508 T	15/10/81
		WO 8100789 A	19/03/81
US 4155779 A	22/05/79	CA 1118114 A	09/02/82
		FR 2434483 A,B	21/03/80
		GB 2040077 A,B	20/08/80
		JP 55500615 T	04/09/80
		NL 7920078 A,T	30/06/80
		WO 8000509 A	20/03/80