

**(12) STANDARD PATENT APPLICATION (11) Application No. AU 2017200540 A1**  
**(19) AUSTRALIAN PATENT OFFICE**

(54) Title  
**Reversible ratcheting tool with dual pawls**

(51) International Patent Classification(s)  
**B25B 13/46** (2006.01)

(21) Application No: **2017200540** (22) Date of Filing: **2017.01.27**

(43) Publication Date: **2017.02.23**

(43) Publication Journal Date: **2017.02.23**

(62) Divisional of:  
**2013323577**

(71) Applicant(s)  
**Apex Brands, Inc.**

(72) Inventor(s)  
**ANDERSON, ALAN D.;XU, Yongsheng**

(74) Agent / Attorney  
**Spruson & Ferguson, L 35 St Martins Tower 31 Market St, Sydney, NSW, 2000, AU**

## REVERSIBLE RATCHETING TOOL WITH DUAL PAWLS

### ABSTRACT

A ratcheting tool (10), the ratcheting tool (10) comprising: a head (14) comprising a cavity (16, 18, 24); a gear ring (48) disposed in the head (14) rotatably about a vertical axis and defining a first plurality of teeth (52), the first plurality of teeth (52) defining at least one first arc; a first pawl (94a) disposed in the head (14) so that the first pawl (94a) is slidable laterally within the cavity (16) with respect to the vertical axis between a first position in which the first pawl (94a) is disposed between the head (14) and the gear ring (48) so that the head (14) transmits torque through the first pawl (94a) in a first rotational direction, and a second position in which the first pawl (94a) is disposed between the head (14) and the gear ring (48) so that the head (14) transmits torque through the first pawl (94a) in an opposite second rotational direction, the first pawl (94a) defining a front face and a rearward face extending between an upper surface and a lower surface of the first pawl (94a), and a second plurality of teeth (102) on the front face of the first pawl (94a) for engaging the first plurality of teeth (52), the second plurality of teeth (102) defining at least one second arc, wherein the rearward face of the first pawl (94a) is separated from the at least one first arc by a first offset in a direction perpendicular to the vertical axis; and a second pawl (94b) disposed in the head (14) above the first pawl (94a) in a direction parallel to the axis of the gear ring (48) and so that the second pawl (94b) is slidable laterally within the cavity (16, 18, 24) with respect to the vertical axis between a first position in which the second pawl (94b) is disposed between the head (14) and the gear ring (48) so that the head (14) transmits torque through the second pawl (94b) in the first rotational direction, and a second position in which the second pawl (94b) is disposed between the head (14) and the gear ring (48) so that the head (14) transmits torque through the second pawl (94b) in the opposite second rotational direction, the second pawl (94b) defining a front face and a rearward face extending between an upper surface and a lower surface of the second pawl (94b), and a third plurality of teeth (102) on the front face of the second pawl (94b) for engaging the first plurality of teeth (52), the third plurality (102) of teeth defining at least one third arc, wherein the rearward face of the second pawl (94b) is separated from the at least one third arc by a second offset in a direction perpendicular to the vertical axis, wherein one of the first offset and the second offset is less than the other of the first offset and the second offset.

## REVERSIBLE RATCHETING TOOL WITH DUAL PAWLS

[0001] This application is a divisional application of Australian Patent No. 2013323577, and all of its contents are herein incorporated by reference.

### Field of the Invention

[0002] The present invention relates generally to hand tools. More particularly, the present invention relates to a wrench that includes a ratcheting feature.

### Background

[0003] Ratcheting tools, for example ratchets and wrenches, often include a generally cylindrical ratchet gear and a pawl that controls the gear's ratcheting direction so that the gear may rotate in one direction but is prevented from rotation in the other. It is often desirable to utilize ratchet wrenches in environments, such as an engine compartment of an automobile, where space restrictions limit the ability to adequately rotate a standard wrench and, therefore, fastener. As well, ratchet wrenches are desirable wherein removal and reapplication of a standard wrench to a fastener are similarly limited.

[0004] Even with the advantages offered by known ratchet wrenches, it is not uncommon for the ratchet wrenches to be used in situations where there is insufficient clearance to fully rotate the wrench and obtain an effective ratcheting action for either tightening or loosening a fastener. In order to overcome this problem, ratchet wrenches with a greater number of teeth on the gear, and corresponding pawl, have been utilized. This reduces the back swing arc and permits use of the wrench in more confined spaces. However, the greater number of teeth results in a plurality of thinner (or fine) teeth, each of which has reduced mechanical strength than the thicker teeth on a standard ratchet. As such, there is a greater possibility of damage to the fine teeth.

[0005] It is an object of the present invention to overcome or at least ameliorate the foregoing disadvantage.

## Summary of the Disclosure

[0006] In a first aspect the present invention provides a ratcheting tool, the ratcheting tool comprising:

a head comprising a cavity;

a gear ring disposed in the head rotatably about a vertical axis and defining a first plurality of teeth, the first plurality of teeth defining at least one first arc;

a first pawl disposed in the head so that the first pawl is slidable laterally within the cavity between

a first position in which the first pawl is disposed between the head and the gear ring so that the head transmits torque through the first pawl in a first rotational direction, and

a second position in which the first pawl is disposed between the head and the gear ring so that the head transmits torque through the first pawl in an opposite second rotational direction,

the first pawl defining a front face and a rearward face extending between an upper surface and a lower surface of the first pawl, and a second plurality of teeth on the front face of the first pawl for engaging the first plurality of teeth, the second plurality of teeth defining at least one second arc, wherein the rearward face of the first pawl is separated from the at least one first arc by a first offset in a direction perpendicular to the vertical axis; and

a second pawl disposed in the head above the first pawl in a direction parallel to the axis of the gear ring and so that the second pawl is slidable laterally within the cavity between

a first position in which the second pawl is disposed between the head and the gear ring so that the head transmits torque through the second pawl in the first rotational direction, and

a second position in which the second pawl is disposed between the head and the gear ring so that the head transmits torque through the second pawl in the opposite second rotational direction,

the second pawl defining a front face and a rearward face extending between an upper surface and a lower surface of the second pawl, and a third plurality of teeth on the front face of the second pawl for engaging the first plurality of teeth, the third plurality of teeth defining at least one third arc, wherein the rearward face of the second pawl is separated from the at least one third arc by a second offset in a direction perpendicular to the vertical axis,

wherein one of the first offset and the second offset is less than the other of the first offset and the second offset.

[0007] In a second aspect the present invention provides a ratcheting tool, the ratcheting tool comprising:

a head comprising a cavity;

a gear ring disposed in the head rotatably about a vertical axis and defining a first plurality of teeth;

a first pawl disposed in the head so that the first pawl is slidable laterally and longitudinally within the cavity between

a first position in which the first pawl is disposed between the head and the gear ring so that the head transmits torque through the first pawl in a first rotational direction, and

a second position in which the first pawl is disposed between the head and the gear ring so that the head transmits torque through the first pawl in an opposite second rotational direction,

the first pawl defining a front face and a rearward face extending between an upper surface and a lower surface of the first pawl, and a second plurality of teeth on the front face of the first pawl for engaging the first plurality of teeth; and

a second pawl disposed in the head so that the second pawl is slidable laterally and longitudinally with respect to the longitudinal center axis of the handle between

a first position in which the second pawl is disposed between the head and the gear ring so that the head transmits torque through the second pawl in the first rotational direction, and

a second position in which the second pawl is disposed between the head and the gear ring so that the head transmits torque through the second pawl in the opposite second rotational direction,

the second pawl defining a front face and a rearward face extending between an upper surface and a lower surface of the second pawl, and a third plurality of teeth on the front face of the second pawl for engaging the first plurality of teeth,

wherein when the first pawl and the second pawl are configured so that if the first pawl and the second pawl are disposed with the rearward faces of the first pawl and the second pawl in vertical alignment and so that a common vertical plane bisects each of the first pawl and second pawl, the second plurality of teeth of the first pawl is offset from the third plurality of teeth of the second pawl in a direction in the common vertical plane and perpendicular to the vertical axis of the gear ring.

[0008] In a third aspect the present invention provides a ratcheting tool, the ratcheting tool comprising:

a head comprising a cavity;

a gear ring disposed in the head and defining a first plurality of teeth;

a first pawl disposed in the head so that the first pawl is slidable laterally within the cavity between

a first position in which the first pawl is disposed between the head and the gear ring so that the head transmits torque through the first pawl in a first rotational direction, and

a second position in which the first pawl is disposed between the head and the gear ring so that the head transmits torque through the first pawl in an opposite second rotational direction,

the first pawl defining a front face and a rearward face extending between an upper surface and a lower surface of the first pawl, and a second plurality of teeth on the front face of the first pawl for engaging the first plurality of teeth, the second plurality of teeth defining at least one first arc; and

a second pawl disposed in the head above the first pawl in a direction parallel to the axis of the gear ring and so that the second pawl is slidable laterally within the cavity between

a first position in which the second pawl is disposed between the head and the gear ring so that the head transmits torque through the second pawl in the first rotational direction, and

a second position in which the second pawl is disposed between the head and the gear ring so that the head transmits torque through the second pawl in the opposite second rotational direction,

the second pawl defining a front face and a rearward face extending between an upper surface and a lower surface of the second pawl, and a third plurality of teeth on the front face of the second pawl for engaging the first plurality of teeth, the third plurality of teeth defining at least one second arc,

wherein the first pawl and the second pawl are configured so that if the first pawl and the second pawl are disposed with the rearward faces of the first pawl and the second pawl in vertical alignment and so that a common vertical plane bisects each of the first pawl and the second pawl, the at least one second arc of the first pawl and the at least one third arc of the second pawl are offset from each other.

[0009] One embodiment of a ratcheting tool in accordance with the present disclosure includes a head and a handle attached to the head, and a gear ring disposed in the head rotatably about a vertical axis and defining a first plurality of teeth about an outer circumference of the gear ring so that the first plurality of teeth define a first arc having a first radius. A first pawl is disposed in the head so that the first pawl is slidable laterally with respect to a longitudinal center axis of the handle between a first position in which the first pawl is disposed between the head and the gear ring so that the head transmits torque through the first pawl in a first rotational direction, and a second position in which the first pawl is disposed between the head and the gear ring so that the head transmits torque through the first pawl in an opposite second rotational direction. The first pawl defines a front face and a rearward face extending between an upper surface and a lower surface of the first pawl, and a second plurality of teeth on the front face of the first pawl for engaging the first plurality of teeth, the front face being concave so that the second plurality of teeth defines at least one second arc having a second radius. A second pawl is disposed in the head above the first pawl in a direction parallel to the axis of the gear ring and so that the second pawl is slidable laterally with respect to the longitudinal center axis of the handle between a first position in which the second pawl is disposed between the head and the gear ring so that the head transmits torque through the second pawl in the first rotational direction, and a second position in which the second pawl is disposed between the head and the gear ring so that the head transmits torque through the second pawl in the opposite second rotational direction. The second pawl defines a front face and a rearward face extending between an upper surface and a lower surface of the second pawl, and a third plurality of teeth on the front face of the second pawl for engaging the first plurality of teeth, the front face being concave so that the third plurality of teeth defines at least one third arc having a third radius. The first pawl and the second pawl are configured so that if the first pawl and the second pawl are disposed with the rearward faces of the first pawl and the second pawl in vertical alignment and so that a common vertical plane bisects each of the first pawl and the second pawl, the at least one second arc of the first pawl and the at least one third arc of the second pawl are offset from each other in a direction in the common vertical plane and perpendicular to the vertical axis of the gear ring.

[0010] An alternate embodiment of a ratcheting tool in accordance with the present disclosure includes a head and a handle attached to the head, and a gear ring disposed in the head rotatably about a vertical axis and defining a first plurality of teeth about an outer circumference of the gear ring. A first pawl is disposed in the head so that the first pawl is slidable laterally and longitudinally with respect to a longitudinal center axis of the handle between a first position in

which the first pawl is disposed between the head and the gear ring so that the head transmits torque through the first pawl in a first rotational direction, and a second position in which the first pawl is disposed between the head and the gear ring so that the head transmits torque through the first pawl in an opposite second rotational direction. The first pawl defines a front face and a rearward face extending between an upper surface and a lower surface of the first pawl, and a second plurality of teeth on the front face of the first pawl for engaging the first plurality of teeth, the front face being concave. A second pawl is disposed in the head so that the second pawl is slidable laterally and longitudinally with respect to the longitudinal center axis of the handle between a first position in which the second pawl is disposed between the head and the gear ring so that the head transmits torque through the second pawl in the first rotational direction, and a second position in which the second pawl is disposed between the head and the gear ring so that the head transmits torque through the second pawl in the opposite second rotational direction. The second pawl defines a front face and a rearward face extending between an upper surface and a lower surface of the second pawl, and a third plurality of teeth on the front face of the second pawl for engaging the first plurality of teeth, the front face being concave. The first pawl and the second pawl are configured so that if the first pawl and the second pawl are disposed with the rearward faces of the first pawl and the second pawl in vertical alignment and so that a common vertical plane bisects each of the first and second pawl, the second plurality of teeth of the first pawl is offset from the third plurality of teeth of the second pawl in a direction in the common vertical plane and perpendicular to the vertical axis of the gear ring.

[0011] Yet another embodiment of a ratcheting tool in accordance with the present disclosure comprises:

- a head and a handle attached to the head; a gear ring disposed in the head and defining a first plurality of teeth about an outer circumference of the gear ring;

- a first pawl disposed in the head so that the first pawl is slidable laterally with respect to a longitudinal center axis of the handle between

- a first position in which the first pawl is disposed between the head and the gear ring so that the head transmits torque through the first pawl in a first rotational direction, and

- a second position in which the first pawl is disposed between the head and the gear ring so that the head transmits torque through the first pawl in an opposite second rotational direction,

- the first pawl defining a front face and a rearward face extending between an upper surface and a lower surface of the first pawl, and a second plurality of teeth on the front face of



the first pawl for engaging the first plurality of teeth, the front face being concave so that the second plurality of teeth defines at least one first arc, wherein the rearward face of the first pawl is separated from the at least one first arc by a first offset in a direction perpendicular to an axis of the gear ring; and

a second pawl disposed in the head above the first pawl in a direction parallel to the axis of the gear ring and so that the second pawl is slidable laterally with respect to the longitudinal center axis of the handle between

a first position in which the second pawl is disposed between the head and the gear ring so that the head transmits torque through the second pawl in the first rotational direction, and

a second position in which the second pawl is disposed between the head and the gear ring so that the head transmits torque through the second pawl in the opposite second rotational direction,

the second pawl defining a front face and a rearward face extending between an upper surface and a lower surface of the second pawl, and a third plurality of teeth on the front face of the second pawl for engaging the first plurality of teeth, the front face of the second pawl being concave so that the third plurality of teeth defines at least one second arc, wherein the rearward face of the second pawl is separated from the at least one second arc by a second offset in a direction perpendicular to the axis of the gear ring,

wherein one of the first offset and the second offset is less than the other of the first offset and the second offset.

### **Brief Description of the Drawings**

[0012] A full and enabling disclosure of the present disclosure, including the best mode thereof, directed to one of ordinary skill in the art, is set forth in the specification, which makes reference to the appended drawings, in which

[0013] Figure 1 is a perspective view of a ratcheting tool in accordance with an embodiment of the present disclosure;

[0014] Figure 2 is an exploded view of the ratcheting tool as in Figure 1;

[0015] Figure 3A is a sectional view of the body of ratcheting tool as in Figure 1;

[0016] Figure 3B is a partial sectional view of the ratcheting tool as in Figure 1;

[0017] Each of Figures 4A through 4D is a top view, partly in section, of the ratcheting tool as in Figure 1;

[0018] Each of Figures 5A through 5D is an elongated view of a portion of the components shown in Figure 4;

[0019] Figure 6A is a top view of a ratchet gear and release button of the ratcheting tool as in Figure 1;

[0020] Each of Figures 6B and 6C is a side view, partly in section, of the ratchet gear and release button as in Figure 6A;

[0021] Figure 7 is a top view of a lower pawl of a ratcheting tool as in Figure 1;

[0022] Figure 8 is a perspective view of the lower pawl as in Figure 7;

[0023] Figure 9 is a top view of an upper pawl of a ratcheting tool as in Figure 1;

[0024] Figure 10 is a perspective view of the upper pawl as in Figure 9;

[0025] Figure 11 is a top view of the reversing lever of the ratcheting tool shown in Figure 1;

[0026] Figure 11A is a partial side view, in section, of the reversing lever of Figure 11;

[0027] Figure 12 is a bottom view, partly in section, of the reversing lever shown in Figure 11;

[0028] Figure 13 is an exploded view of the reversing lever shown in Figure 11;

[0029] Figure 14 is a side view of a lower pusher as shown in Figure 13;

[0030] Figure 14A is a cross-sectional view of the lower pusher shown in Figure 14;

[0031] Figure 15 is a front view of the lower pusher shown in Figure 14;

[0032] Figure 16 is a top view of the upper and the lower pawls of the ratcheting tool shown in Figure 1, in a stacked configuration;

[0033] Figure 17 is a top view of a lower pawl of a ratcheting tool in accordance with an alternate embodiment of the present disclosure;

[0034] Figure 18 is a perspective view of the lower pawl as in Figure 17;

[0035] Figure 19 is a top view of an upper pawl of a ratcheting tool in accordance with an alternate embodiment of the present disclosure;

[0036] Figure 20 is a perspective view of the upper pawl as in Figure 19; and

[0037] Figure 21 is a top view of the upper and lower pawls, as shown in Figures 17 and 19, respectively, in a stacked configuration.

[0038] Repeat use of reference characters in the present specification and drawings is intended to represent same or analogous features or elements of the invention.

### **Detailed Description**

[0039] Reference will now be made in detail to various embodiments of the invention, one or more examples of which are illustrated in the accompanying drawings. Each example is provided by way of explanation of the invention, not limitation of the invention. In fact, it will be apparent to those skilled in the art that modifications and variations can be made in the present invention without departing from the scope and spirit thereof. For instance, features illustrated or described as part of one embodiment may be used on another embodiment to yield a still further embodiment. Thus, it is intended that the present invention covers such modifications and variations as come within the scope of the appended claims and their equivalents.

[0040] Referring to Figure 1, a ratcheting tool 10 includes an elongated arm, which may be formed as a handle 12 from stainless steel, metal alloys or other suitable materials. The length of handle 12 may vary depending on the application of ratcheting tool 10. A head 14 extends from the handle 12, and the head and handle may be integrally formed from the same material.

[0041] Referring to Figures 2, 3A, and 3B, head 14 defines a relatively large and generally cylindrical through-hole compartment 16. A web portion 20 is intermediate to head 14 and

handle 12 and defines a smaller, wedge-shaped compartment 18 (see also Figures 4A and 4B). A generally cylindrical compartment 24 extends through a top face 22 into web 20 at a hole 26 and overlaps compartment 18. Compartment 18 is closed above by top face 22 and opens into both compartments 16 and 24. The underside of head 14 is open and receives a cover 28 that secures certain components of ratcheting tool 10 within compartments 16, 18, and 24, as described in greater detail below.

[0042] A wall 30 defines compartment 16 between a radially outward extending ledge 32 at one end and a radially inward extending ledge 34 at its other end. An annular groove 36 is defined in a vertical wall extending down from ledge 32 and surrounding most of compartment 16.

[0043] Cover 28 has an annular portion 40 defining a hole 42 and a tab portion 44 extending from annular portion 40. An opening 35 in the bottom of head 14 and web 20 receives cover 28 so that annular portion 40 sits on ledge 32. Annular groove 36 receives a C-clip 46 to secure cover 28 between the C-clip and ledge 32 so that cover 28 is held in position over compartments 16, 18, and 24.

[0044] Compartment 16 receives an annular gear ring 48 having an inner surface 50 that is concentric with wall 30 of head 14. As shown in Figures 6A through 6C, the outer circumference of gear ring 48 defines an annular array of vertically-aligned teeth 52. More specifically, the embodiment shown preferably includes sixty (60) gear teeth 52 evenly spaced about the outer surface of gear ring, meaning the gear ring 48 has an index of 60. The gear ring's bottom side defines an extension portion 56 surrounded by a flat annular shoulder 58 that defines an annular groove 60. On the top side, a top ledge 62 surrounds an upwardly extending wall 64. Gear ring 48 fits into compartment 16 so that wall 64 extends through a hole 23 in top face 22 and so that ledge 62 abuts ledge 34. When cover 28 is secured to head 14, extension portion 56 extends through hole 42. Circular portion 40 abuts shoulder 58, thereby retaining gear ring 48 in compartment 16.

[0045] Extension portion 56 and wall 64 fit through hole 42 and hole 23, respectively, with sufficient clearance so that the gear ring is secured in the radial direction yet is permitted to rotate with respect to head 14. A lower O-Ring 66 is received in annular groove 60 and abuts cover 28, while an upper O-ring extends around wall 64 between ledges 21 and 62. The O-rings aid in smooth rotation of gear ring 48 and minimize the amount of dirt and debris that can enter

compartment 16. O-Rings 66 may be formed from pliable rubbers, silicones, metals, or other suitable material.

[0046] Extension portion 56 is square shaped in cross-section and is adapted to receive a standard three-eighths (3/8) inch drive socket, which should be well understood in the art. Extension 56 may also be sized to fit one-quarter (1/4) inch drive, one-half (1/2) inch drive, or other drive size sockets as desired.

[0047] Inner surface 50 of gear ring 48 surrounds a blind bore 68 centered around the axis of gear ring 48. Bore 68 receives a push button 76 having an annular top 78 and a cylindrical shaft 80. The top end of bore 68 defines a shoulder 82 that is peened inward to retain button 76 in the bore. A spring 84 and ball 86 in the bottom of bore 68 bias button 76 upward against shoulder 82. A cylindrical bore 90 intersects bore 68 at a right angle and receives a ball 92. An edge 88 is peened inward to retain the ball in the bore.

[0048] Ball 86 controls the position of ball 92 within bore 90. Normally, when spring 84 and ball 86 push the top of button 76 up against shoulder 82, ball 86 is aligned with ball 92, thereby pushing ball 92 out against edge 88 of bore 90. In this position, a portion of ball 92 extends out of bore 90 to retain a socket on extension 56. To remove the socket, the operator pushes push button 76 down against spring 84. This moves ball 86 below bore 90 and aligns a narrowed end of shaft 80 with ball 92, thereby allowing ball 92 to move back into bore 90 and releasing the socket.

[0049] Referring to Figures 4A through 4D, compartment 18 receives a pair of generally wedge-shaped pawls, more specifically, a lower pawl 94a and an upper pawl 94b, in a stacked configuration between side walls 98 and 100. Cover 28 and top face 22 (Figure 2) of web 20 retain lower and upper pawls 94a and 94b from below and above. Walls 98 and 100 are formed so that vertical planes (i.e. planes perpendicular to the page) defined by the walls intersect a vertical plane 99 that passes through the center of compartments 16 and 24 (see Figures 2 and 3A) at an angle such that compartment 18 optimizes the load-bearing and ratcheting capabilities of ratcheting tool 10. The size of the angle may vary depending on the tool's intended use. A larger angle, for example, allows for greater load-carrying characteristics between lower and upper pawls 94a and 94b and gear ring 48, while a smaller angle provides for better ratcheting and reversing. Thus, the angle chosen in a given instance preferably provides the best

combination of gear/pawl tooth loading and clearance for the pawls during ratcheting and reversing. In a preferred embodiment, the angle between plane 99 and each of side walls 98 and 100 is 31 degrees and is preferably within a range of 27 degrees to 35 degrees.

[0050] As shown in Figures 7 and 8, lower pawl 94a defines a plurality of vertically aligned teeth 102 across the pawl's front face in an arc having a radius R1. In the illustrated embodiment, lower pawl includes eleven teeth 102, the tips of the teeth are rounded slightly, and R1 is measured to the rounded tips of the teeth. The radius R1 is the same as a radius R2 (Figure 6A) between the center 68 of gear ring 48 and the troughs of its teeth 52. Because of manufacturing tolerances, the tips of the pawl teeth and the troughs of the gear teeth vary slightly in the radial direction, as should be understood in this art. Thus, radii R1 and R2 should be understood to lie within the pawl and gear tolerance ranges and are assumed to extend to the mid-points of the respective tolerance range for purposes of this discussion. Furthermore, it should be understood that radii R1 and R2 may be taken at other locations on the gear and the pawl, for example at the tips of the gear teeth and the troughs of the pawl teeth. As well, in the embodiment shown, teeth 102 are evenly spaced on the pawl's front face so that lower pawl 94a has the same index, that being 60, as the gear teeth 52.

[0051] The rearward face 93 of lower pawl 94a defines a pocket 104 having two curved portions 108 and 110 separated by a bridge 112 and having symmetric rearwardly-extending sides 114 and 116. A notch 118 extends into the back end of lower pawl 94a from a bottom surface 120. The remainder of rearward face 93 of lower pawl 94a is defined by first and second smooth, continuous portions 93a and 93b disposed on opposite sides of pocket 104.

[0052] As shown in Figures 9 and 10, upper pawl 94b defines a plurality of vertically aligned teeth 102 across the pawl's front face in an arc having a radius R1. In the illustrated embodiment, upper pawl includes ten teeth 102, the tips of the teeth are rounded slightly, and R1 is measured to the rounded tips of the teeth. The radius R1 is the same as a radius R2 (Figure 6A) between the center 68 of gear ring 48 and the troughs of its teeth 52. Similarly to lower pawl 94a, because of manufacturing tolerances, the tips of the pawl teeth and the troughs of the gear teeth vary slightly in the radial direction, as should be understood in this art. Thus, radii R1 and R2 should be understood to lie within the pawl and gear tolerance ranges and are assumed to extend to the mid-points of the respective tolerance range for purposes of this discussion. Furthermore, it should be understood that radii R1 and R2 may be taken at other locations on the

gear and the pawl, for example at the tips of the gear teeth and the troughs of the pawl teeth. As well, in the embodiment shown, teeth 102 are evenly spaced on the pawl's front face so that upper pawl 94b has the same index, that being 60, as the gear teeth 52.

[0053] Additionally, rearward face 93 of upper pawl 94b defines a pocket 104 having two curved portions 108 and 110 separated by a bridge 112 and having symmetric rearwardly extending sides 114 and 116. Similarly to lower pawl 94a, the remainder of rearward face 93 of upper pawl 94b is defined by first and second smooth, continuous portions 93a and 93b disposed on opposite sides of pocket 104. Preferably, first and second portions 93a and 93b of upper pawl's rearward face 93 are formed identically to first and second portions 93a and 93b of lower pawl's rearward face 93.

[0054] Referring now to Figure 16, a top view of upper and lower pawls 94b and 94a in a stacked configuration is provided in which the rearward faces, more specifically, first and second portions 93a and 93b of each rearward face, of upper pawl 94b and lower pawl 94a, are vertically aligned. As well, the pawls are positioned such that their longitudinal center axes lie in a common vertical plane. As previously discussed, gear ring 48 preferably defines 60 gear teeth 52 evenly spaced about its outer circumference, meaning the teeth are disposed every 60. Similarly, teeth 102 of lower pawl 94a and upper pawl 94b are disposed along their respective front faces at 60 increments. Note, however, that when their longitudinal center axes are aligned, teeth 102 of lower pawl 94a are circumferentially offset from teeth 102 of upper pawl 94b by approximately one-half pitch, meaning by approximately 30 in the present case. As discussed in greater detail below, the effect of the circumferential offset of the pawl teeth is equivalent to doubling the number of gear teeth 52 from 60 teeth to 120 teeth. As such, the ratcheting index of the wrench is decreased from approximately 60 to approximately 30.

[0055] Still referring to Figure 16, in the embodiment shown, an arc defined by teeth 102 of lower pawl 94a is offset from an arc defined by teeth 102 of upper pawl 94b in a direction that is parallel to the longitudinal center axes of the pawls. In short, the net effect of the offset is that the pawl having the fewer number of teeth, that being upper pawl 94b, is "thicker" than the lower pawl 94a in a direction parallel to the longitudinal center axes of the pawl. As shown, the offset (X) is preferably between approximately 0.002 to 0.008 inches, most preferably being approximately 0.005 inches.

[0056] Referring to Figures 11, 11 A, 12 and 13, a reversing lever 122 includes a handle portion 124 and a bottom portion 126. The outer surface of bottom 126 defines an annular groove 128 that receives an O-ring 130, which extends slightly outward of groove 128. Groove 128 is located proximate handle portion 124 such that an annular shelf 132 extends between groove 128 and the front of handle 124. Bottom 126 defines a lower blind bore 134a and an upper blind bore 134b that receive a lower spring 136a and pusher 138a, and an upper spring 136b and pusher 138b, respectively. Referring to Figures 14, 14A and 15, lower pusher 138a is cylindrical in shape and defines a blind bore 140 in its rear end and a rounded front end 142. Bore 140 is adapted to receive lower spring 136a so that the spring biases lower pusher 138a radially outward from bore 134. Upper spring 136b and upper pusher 138b are identical in construction to lower spring 136a and lower pusher 138a.

[0057] Referring to Figures 2, 3B, 1 1A and 13, hole 26 in web 20 receives the lever's bottom portion 126. The diameter of bottom portion 126 is approximately equal to the diameter of hole 26, although sufficient clearance is provided so that the reversing lever rotates easily in the hole. Upon insertion of bottom portion 126 into hole 26, the hole's side pushes O-ring 130 radially inward into groove 128 so that the O-ring thereafter inhibits the entrance of dirt into the compartment. Referring also to Figure 7, lower pusher 138a extends into pocket 104 of lower pawl 94a and engages curved portions 108 and 110 and sides 114 and 116, depending on the position of the pawl and lever. Similarly, upper pusher 138b extends into pocket 104 of upper pawl 94b and engages curved portion 108 and 110 and sides 114 and 116, depending on the position of the pawl and lever. A radially outward extending lip 144 at the bottom of the lever fits into notch 118 in the pawl, and a lip 145 extends into a groove at the bottom of compartment 24, thereby axially retaining lever 122 its compartment.

[0058] In operation, as shown in Figures 4A and 4B, lower and upper pawls 94a and 94b may slide to either side of compartment 18 laterally with respect to the gear between two positions in which the pawl is wedged between the body and the gear. In Figure 4B, lever 122 is rotated to its most clockwise position, and both lower pawl 94a and upper pawl 94b are wedged between gear ring 48 and top side 98 of compartment 18. Lower and upper springs 136a and 136b push lower and upper pushers 138a and 138b, respectively, forward so that the pushers' front ends 142 engage the respective pocket sides 114 and thereby bias the respective pawls to the wedged position. Note, Figure 4B shows the positions of upper and lower pawls 94a and 94b relative to gear ring 48 at the onset of the ratcheting process. As such, the faces and, therefore, teeth 102 of



upper and lower pawls 94a and 94b, are disengaged from gear teeth 52 as the pawls are pivoted away from the gear about their outermost teeth 102a and 102b, as discussed in greater detail below. However, if torque is applied to handle 12 (Figure 2) in the clockwise direction when a socket on the gear extension engages a work piece, the top side of compartment 18 pushes pawl teeth 102 of the lower and upper pawls 94a and 94b against opposing gear teeth 52 as best seen in Figure 4D. As shown, during application of torque, upper and lower pawls 94a and 94b pivot inwardly towards gear ring 48, with lower pawl 94a, in the instant case, being fully engaged with the gear ring. That is, the pawls remain wedged between the gear ring and the compartment's top edge, and the force applied from the operator's hand to the pawl through top side 98 is therefore applied in the clockwise direction to the work piece through gear ring 48. Figure 4C shows the application of torque to a fastener when lever 122 is rotated in its most counter-clockwise position and both lower and upper pawls 94a and 94b are wedged between gear ring 48 and bottom side 100 of compartment 18.

[0059] Referring additionally to Figures 5A through 5D, if an operator applies torque to the handle in the counter-clockwise direction, gear teeth 52 apply a counterclockwise reaction force to lower and upper pawls 94a and 94b. As best seen in Figure 5A, at the onset of the ratcheting process, an outermost tooth 102a of bottom pawl 94a is fully seated between gear teeth 52a and 52b, whereas the tip of an outermost tooth 102b of upper pawl 94b is disposed at approximately the midpoint of a leading edge 53 of gear tooth 52a. If gear ring 48 remains rotationally fixed to a work piece through a socket, gear teeth 52 hold the pawls so that the pawls pivot slightly relative to gear ring 48 in from the top end of the pawl (as viewed in Figure 4B) and moves back and down into compartment 18. As the operator applies increasing torque to the handle, the torque eventually overcomes the biasing force of springs 136a and 136b. This causes pawl pocket sides 114 (Figures 7 and 8) of both lower and upper pawls 94a and 94b to push back against the respective pusher tips 142 and the force of the corresponding springs. Eventually, outermost teeth 102a and 102b of lower and upper pawls 94a and 94b, respectively, begin to slide radially outward along leading edges 53 of gear teeth 52b and 52a, respectively. Springs 136a and 136b continue to bias lower and upper pushers 138a and 138b, respectively, forward against sides 114 of their respective pawl pockets 104, forcing both pawls back up toward the top face of compartment 18. As such, lower and upper pawls 94a and 94b maintain contact with side wall 98 of compartment 18 while ratcheting occurs. As previously noted, the pitch of both the gear teeth and pawl teeth in the present embodiment is 60. As such, a rotation of 60 of the

wrench handle is required for both outermost teeth 102a and 102b to move from one trough between consecutive gear teeth to the next.

[0060] Figure 5B shows the disposition of outermost teeth 102a and 102b after the wrench handle has been rotated through approximately 20 in the counter-clockwise direction. As shown, tooth 102a of lower pawl 94a has slid outwardly along a portion of leading edge 53 of gear tooth 52b. Similarly, tooth 102b of upper pawl 94b has slid outwardly along leading edge 53 of gear tooth 52a. Note, however, that tooth 102b is disposed near the outermost tip of gear tooth 52a since it started at a position half-way along the leading edge of gear tooth 52a at the onset of the ratcheting process.

[0061] As shown in Figure 5C, after rotation of the wrench handle through 30 in the counter-clockwise direction, tooth 102b of upper pawl 94b has cleared gear tooth 52a and is fully seated in the adjacent gear tooth trough. As such, the torque wrench has an effective ratcheting index of 3° between torque-applying configurations. As shown, tooth 102a of lower pawl 94a continues to slide outwardly along gear tooth 52b, with both teeth 102a and 102b being disposed in the same gear tooth trough.

[0062] Referring now to Figure 5D, the wrench handle has been rotated through 50 in the counter-clockwise direction. As such, tooth 102a has slid outwardly along almost the entire length of gear tooth 52b. As well, tooth 102b has begun to slide outwardly along leading edge 53 of tooth 52b. Further rotation of the wrench handle, more specifically, approximately 10 so that the entire rotation is approximately 60 from the onset, results in tooth 102a of lower pawl 94a clearing gear tooth 52b and being fully seated in the adjacent trough.

[0063] To change the operative direction of ratcheting tool 10, the operator rotates switch 122 in the counterclockwise direction. Lever bottom portion 126 (Figure 2) rotates in hole 26, and the pushers move counterclockwise in the corresponding pawl pockets through curved portions 108 toward bridges 112 (Figures 7 and 9). Initially, the pawls pivot slightly, and the load-bearing pawl teeth of each pawl move away from the gear teeth. As the pushers move toward the corresponding bridges, each pawl begins to shift down and back in compartment 18. Further rotation brings the pushers into contact with the corresponding bridge, causing the pawl teeth to ride down and back into compartment 18 over the gear teeth. Gear ring 48 may also rotate slightly. In this position, lower and upper pawls 94a and 94b move the pushers back against the

force of the springs. As the operator continues to rotate switch 122, the pushers move into the corresponding curved portions 110 and push forward against the corresponding walls 116. This applies a counterclockwise force to each pawl so that each pawl moves downward in compartment 18 and wedges between the gear ring and the compartment's bottom edge 100. When the pawls have moved over to this wedged position, the configuration and operation of the gear, the pawl, and the lever mirror the pawl's operation described above with respect to Figure 4B. That is, the tool ratchets and applies torque to a work piece in the same manner but in the opposite direction.

[0064] As shown in Figures 17 and 18, a lower pawl 94a in accordance with an alternate embodiment of the present disclosure defines a plurality of vertically-aligned teeth 102 across the pawl's front face, wherein the front face is formed by two arc portions rather than one. As shown, both an upper arc portion 95a, disposed above the longitudinal center axis of the pawl, and a lower arc portion 95b, disposed below the longitudinal center axis of the pawl, have a radius of R1. Note, however, that the center of curvature of both upper arc portion 95a and lower arc portion 95b are offset above and below, respectively, the longitudinal center axis. As such, the arc portions do not form one continuous arc, but rather, two portions that intersect at the longitudinal center axis as shown.

[0065] In the illustrated embodiment, lower pawl 94a includes eleven teeth 102, the tips of the teeth are rounded slightly, and R1 is measured to the rounded tips of the teeth. The radius R1 of each arc portion is the same as a radius R2 (Figure 6A) between the center 68 of gear ring 48 and the troughs of its teeth 52. Because of manufacturing tolerances, the tips of the pawl teeth and the troughs of the gear teeth vary slightly in the radial direction, as should be understood in this art. Thus, radii R1 and R2 should be understood to lie within the pawl and gear tolerance ranges and are assumed to extend to the mid-points of the respective tolerance range for purposes of this discussion. Furthermore, it should be understood that radii R1 and R2 may be taken at other locations on the gear and the pawl, for example at the tips of the gear teeth and the troughs of the pawl teeth. As well, in the embodiment shown, teeth 102 are evenly spaced on the pawl's front face so that both the upper and lower arc portions 95a and 95b of lower pawl 94a have the same index, that being 60, as the gear teeth 52.

[0066] The rearward face 93 of lower pawl 94a defines a pocket 104 having two curved portions 108 and 110 separated by a bridge 112 and having symmetric rearwardly-extending sides 114

and 116. A notch 118 extends into the back end of lower pawl 94a from a bottom surface 120. The remainder of rearward face 93 of lower pawl 94a is defined by first and second smooth, continuous portions 93a and 93b disposed on opposite sides of pocket 104.

[0067] As shown in Figures 19 and 20, upper pawl 94b of the alternate embodiment defines a plurality of vertically-aligned teeth 102 across the pawl's front face, wherein the front face is formed by two arc portions rather than one. As shown, both an upper arc portion 97a, disposed above the longitudinal center axis of the pawl, and a lower arc portion 97b, disposed below the longitudinal center axis of the pawl, have a radius R1. Note, however, that the center of curvature of both upper arc portion 97a and lower arc portion 97b are offset above and below, respectively, the longitudinal center axis. As such, the arc portions do not form one continuous arc, but rather, two portions that intersect at the longitudinal center axis as shown.

[0068] In the illustrated embodiment, upper pawl 94b includes ten teeth 102, the tips of the teeth are rounded slightly, and R1 is measured to the rounded tips of the teeth. The radius R1 is the same as a radius R2 (Figure 6A) between the center 68 of gear ring 48 and the troughs of its teeth 52. Similarly to lower pawl 94a, because of manufacturing tolerances, the tips of the pawl teeth and the troughs of the gear teeth vary slightly in the radial direction, as should be understood in this art. Thus, radii R1 and R2 should be understood to lie within the pawl and gear tolerance ranges and are assumed to extend to the mid-points of the respective tolerance range for purposes of this discussion. Furthermore, it should be understood that radii R1 and R2 may be taken at other locations on the gear and the pawl, for example at the tips of the gear teeth and the troughs of the pawl teeth. As well, in the embodiment shown, teeth 102 are evenly spaced on the pawl's front face so that upper pawl 94b has the same index, that being 60, as the gear teeth 52.

[0069] Additionally, rearward face 93 of upper pawl 94b defines a pocket 104 having two curved portions 108 and 110 separated by a bridge 112 and having symmetric rearwardly extending sides 114 and 116. Similarly to lower pawl 94a, the remainder of rearward face 93 of upper pawl 94b is defined by first and second smooth, continuous portions 93a and 93b disposed on opposite sides of pocket 104. Preferably, first and second portions 93a and 93b of upper pawl's rearward face 93 are formed identically to first and second portions 93a and 93b of lower pawl's rearward face 93.

[0070] Referring now to Figure 21, a top view of upper and lower pawls 94b and 94a in a stacked configuration is provided in which the rearward faces, more specifically, first and second portions 93a and 93b of each rearward face, of upper pawl 94b and lower pawl 94a, are vertically aligned. As well, the pawls are positioned such that their longitudinal center axes lie in a common vertical plane. As previously discussed, gear ring 48 preferably defines 60 gear teeth 52 evenly spaced about its outer circumference, meaning the teeth are disposed every 60. Similarly, teeth 102 of lower pawl 94a and upper pawl 94b are disposed along the respective upper and lower arc portions of their front faces at 6° increments. Note, however, that when their longitudinal center axes are aligned, teeth 102 of lower pawl 94a are circumferentially offset from teeth 102 of upper pawl 94b by approximately one-half pitch, meaning by approximately 30 in the present case. As previously discussed, the effect of the circumferential offset of the pawl teeth is equivalent to doubling the number of gear teeth 52 from 60 teeth to 120 teeth. As such, the ratcheting index of the wrench is decreased from approximately 60 to approximately 30.

[0071] Still referring to Figure 21, in the embodiment shown, upper and lower arc portions 95a and 95b defined by teeth 102 of lower pawl 94a are offset from the corresponding upper and lower arc portions 97a and 97b defined by teeth 102 of upper pawl 94b in a direction that is parallel to the longitudinal center axes of the pawls. In short, the net effect of the offset is that the pawl having the fewer number of teeth, that being upper pawl 94b, is "thicker" than the lower pawl 94a in a direction parallel to the longitudinal center axes of the pawl. As shown, the offset (X) is preferably between approximately 0.002 to 0.008 inches, most preferably being approximately 0.005 inches.

[0072] The operation of the ratcheting tool including upper and lower pawls 94a and 94b (as shown in Figures 17 through 21) is substantially the same as the previously discussed embodiment of the disclosed ratchet wrench. As such, a discussion of the present embodiment is not required here, and is omitted.

[0073] While one or more preferred embodiments of the invention have been described above, it should be understood that any and all equivalent realizations of the present invention are included within the scope and spirit thereof. The embodiments depicted are presented by way of example only and are not intended as limitations upon the present invention. Thus, it should be understood by those of ordinary skill in this art that the present invention is not limited to these

embodiments since modifications can be made. For example, the number of gear teeth can be more or less than the disclosed 60 teeth, the number of teeth on the pawls can vary, the radius of curvature of the arc defined by the teeth on one or both pawls can be greater than or less than the radius of curvature of the gear teeth, the pawl having the greater number of teeth can be disposed on top of the pawl having fewer teeth, the pawl having the reduced number of teeth can be the "thinner" pawl in the direction parallel to the longitudinal center axes of the pawls, etc. Therefore, it is contemplated that any and all such embodiments are included in the present invention as may fall within the scope of the appended claims.

## CLAIMS

1. A ratcheting tool, the ratcheting tool comprising:
  - a head comprising a cavity;
  - a gear ring disposed in the head rotatably about a vertical axis and defining a first plurality of teeth, the first plurality of teeth defining at least one first arc;
  - a first pawl disposed in the head so that the first pawl is slidable laterally within the cavity with respect to the vertical axis between
    - a first position in which the first pawl is disposed between the head and the gear ring so that the head transmits torque through the first pawl in a first rotational direction, and
    - a second position in which the first pawl is disposed between the head and the gear ring so that the head transmits torque through the first pawl in an opposite second rotational direction,
  - the first pawl defining a front face and a rearward face extending between an upper surface and a lower surface of the first pawl, and a second plurality of teeth on the front face of the first pawl for engaging the first plurality of teeth, the second plurality of teeth defining at least one second arc, wherein the rearward face of the first pawl is separated from the at least one first arc by a first offset in a direction perpendicular to the vertical axis; and
  - a second pawl disposed in the head above the first pawl in a direction parallel to the axis of the gear ring and so that the second pawl is slidable laterally within the cavity with respect to the vertical axis between
    - a first position in which the second pawl is disposed between the head and the gear ring so that the head transmits torque through the second pawl in the first rotational direction, and
    - a second position in which the second pawl is disposed between the head and the gear ring so that the head transmits torque through the second pawl in the opposite second rotational direction,
  - the second pawl defining a front face and a rearward face extending between an upper surface and a lower surface of the second pawl, and a third plurality of teeth on the front face of the second pawl for engaging the first plurality of teeth, the third plurality of teeth defining at least one third arc, wherein the rearward face of the second pawl is separated from the at least one third arc by a second offset in a direction perpendicular to the vertical axis,
  - wherein one of the first offset and the second offset is less than the other of the first offset and the second offset.

2. The ratcheting tool of claim 1, wherein the first arc is defined by a plurality of troughs respectively disposed between the first plurality of teeth, the at least one second arc is defined by tips of the second plurality of teeth and the third arc is defined by tips of the third plurality of teeth.
3. The ratcheting tool of claim 1, wherein the difference between the first offset and the second offset is between 0.002 inches (0.051 mm) to 0.008 inches (0.203 mm).
4. The ratcheting tool of claim 1, wherein the difference between the first offset and the second offset is approximately 0.005 inches (0.127 mm).
5. The ratcheting tool of claim 1, wherein a maximum width of the first pawl perpendicular to the direction perpendicular to the vertical axis is substantially the same as a maximum width of the second pawl perpendicular to the direction perpendicular to the vertical axis.
6. A ratcheting tool, the ratcheting tool comprising:
  - a head comprising a cavity;
  - a gear ring disposed in the head rotatably about a vertical axis and defining a first plurality of teeth;
  - a first pawl disposed in the head so that the first pawl is slidable laterally and longitudinally within the cavity with respect to the vertical axis between
    - a first position in which the first pawl is disposed between the head and the gear ring so that the head transmits torque through the first pawl in a first rotational direction, and
    - a second position in which the first pawl is disposed between the head and the gear ring so that the head transmits torque through the first pawl in an opposite second rotational direction,
  - the first pawl defining a front face and a rearward face extending between an upper surface and a lower surface of the first pawl, and a second plurality of teeth on the front face of the first pawl for engaging the first plurality of teeth; and
  - a second pawl disposed in the head so that the second pawl is slidable laterally and longitudinally within the cavity with respect to the vertical axis between
    - a first position in which the second pawl is disposed between the head and the gear ring so that the head transmits torque through the second pawl in the first rotational direction, and



a second position in which the second pawl is disposed between the head and the gear ring so that the head transmits torque through the second pawl in the opposite second rotational direction,

the second pawl defining a front face and a rearward face extending between an upper surface and a lower surface of the second pawl, and a third plurality of teeth on the front face of the second pawl for engaging the first plurality of teeth,

wherein when the first pawl and the second pawl are configured so that if the first pawl and the second pawl are disposed with the rearward faces of the first pawl and the second pawl in vertical alignment and so that a common vertical plane bisects each of the first pawl and second pawl, the second plurality of teeth of the first pawl is offset from the third plurality of teeth of the second pawl in a direction in the common vertical plane and perpendicular to the vertical axis of the gear ring.

7. The ratcheting tool of claim 6, wherein the offset from the second plurality of teeth of the first pawl to the third plurality of teeth of the second pawl in the direction is between 0.002 inches (0.051 mm) and 0.008 inches (0.203 mm).

8. The ratcheting tool of claim 6, wherein the offset from the second plurality of teeth of the first pawl to the third plurality of teeth of the second pawl in the direction is approximately 0.005 inches (0.127 mm).

9. The ratcheting tool of claim 6, wherein:

the first plurality of teeth of the gear ring defines a first arc having a first radius, the second plurality of teeth of the first pawl defines a second arc having a second radius, the third plurality of teeth of the second pawl defines a third arc having a third radius, and the second radius and the third radius are substantially the same length.

10. The ratcheting tool of claim 9, wherein the first arc is defined by a plurality of troughs respectively disposed between the first plurality of teeth, the second arc is defined by tips of the second plurality of teeth and the third arc is defined by tips of the third plurality of teeth.

11. The ratcheting tool either of claim 1 or 6, wherein the first pawl is symmetrical about a vertical plane bisecting the first pawl, and the second pawl is symmetrical about a vertical plane bisecting the second pawl.

12. The ratcheting tool of claim 11, wherein the first pawl and second pawl are configured so that if the first pawl and the second pawl are disposed with the rearward faces of the first and second pawls in vertical alignment and the first and second pawls bisected by a common vertical plane, the second plurality of teeth is circumferentially offset with respect to the third plurality of teeth.

13. The ratcheting tool of claim 12, wherein the circumferential offset between the second plurality of teeth and the third plurality of teeth is approximately one-half tooth width.

14. The ratcheting tool of either claim 1 or 6, the ratcheting tool further comprising:  
a pocket defined in the rearward face of the first pawl, and a shelf formed in the lower surface of the first pawl; and  
a lever defining a lip protruding therefrom and an arm protruding therefrom, the lever being disposed in the head in driving engagement with the first pawl and the second pawl so that actuation of the arm of the lever drives the first and the second pawls between their respective first positions and their respective second positions, wherein the lip is received by the first pawl shelf.

15. The ratcheting tool of claims 1 or 6, wherein:  
the first plurality of teeth defines a first arc having a first radius; and  
the second plurality of teeth of the first pawl includes a first tooth portion and a second tooth portion defining respective second arcs each having a second radius, wherein positions of respective centers of curvature of the second arcs are different from each other.

16. The ratcheting tool of claim 15, wherein:  
the third plurality of teeth of the second pawl includes a first tooth portion and a second tooth portion defining respective third arcs each having a third radius, wherein positions of respective centers of curvature of the third arcs are different from each other.

17. The ratcheting tool of claim 16, wherein:  
the centers of curvature of the second arcs are on opposite sides of a vertical plane bisecting the first pawl, and  
the centers of curvature of the third arcs are on opposite sides of a vertical plane bisecting the second pawl.

18. The ratcheting tool of claim 16, wherein the second radii and the third radii are substantially the same length.
19. The ratcheting tool of claim 18, wherein the first radius is substantially the same length as the second radii.
20. The ratcheting tool of claim 1, comprising at least one resilient element disposed between the head and the rearward faces of the first pawl and second pawl, biasing the first pawl and the second pawl toward the gear ring, and wherein the rearward face of the first pawl is defined by a surface of the first pawl engaged by the at least one resilient element and the rearward face of the second pawl is defined by a surface of the second pawl engaged by the at least one resilient element.
21. The ratcheting tool of claim 6, comprising at least one resilient element disposed between the head and the rearward faces of the first pawl and second pawl, biasing the first pawl and the second pawl toward the gear ring, and wherein the rearward face of the first pawl is defined by a surface of the first pawl engaged by the at least one resilient element and the rearward face of the second pawl is defined by a surface of the second pawl engaged by the at least one resilient element.
22. A ratcheting tool, the ratcheting tool comprising:  
a head comprising a cavity;  
a gear ring disposed in the head and defining a first plurality of teeth;  
a first pawl disposed in the head so that the first pawl is slidable laterally within the cavity with respect to the vertical axis between  
a first position in which the first pawl is disposed between the head and the gear ring so that the head transmits torque through the first pawl in a first rotational direction, and  
a second position in which the first pawl is disposed between the head and the gear ring so that the head transmits torque through the first pawl in an opposite second rotational direction,  
the first pawl defining a front face and a rearward face extending between an upper surface and a lower surface of the first pawl, and a second plurality of teeth on the front face of the first pawl for engaging the first plurality of teeth, the second plurality of teeth defining at least one first arc; and

a second pawl disposed in the head above the first pawl in a direction parallel to the axis of the gear ring and so that the second pawl is slidable laterally within the cavity with respect to the vertical axis between

a first position in which the second pawl is disposed between the head and the gear ring so that the head transmits torque through the second pawl in the first rotational direction, and

a second position in which the second pawl is disposed between the head and the gear ring so that the head transmits torque through the second pawl in the opposite second rotational direction,

the second pawl defining a front face and a rearward face extending between an upper surface and a lower surface of the second pawl, and a third plurality of teeth on the front face of the second pawl for engaging the first plurality of teeth, the third plurality of teeth defining at least one second arc,

wherein the first pawl and the second pawl are configured so that if the first pawl and the second pawl are disposed with the rearward faces of the first pawl and the second pawl in vertical alignment and so that a common vertical plane bisects each of the first pawl and the second pawl, the at least one first arc of the first pawl and the at least one second arc of the second pawl are offset from each other.

23. The ratcheting tool of claim 22, wherein the rearward face of the first pawl and the rearward face of the second pawl have corresponding shapes.

24. The ratcheting tool of any of claims 1, 6, and 22, wherein

a first length extends linearly between respective outermost teeth on opposing ends of the second plurality of teeth,

a second length extends linearly between respective outermost teeth on opposing ends of the third plurality of teeth, and

one of the first length and the second length is greater than the other of the first length and the second length.

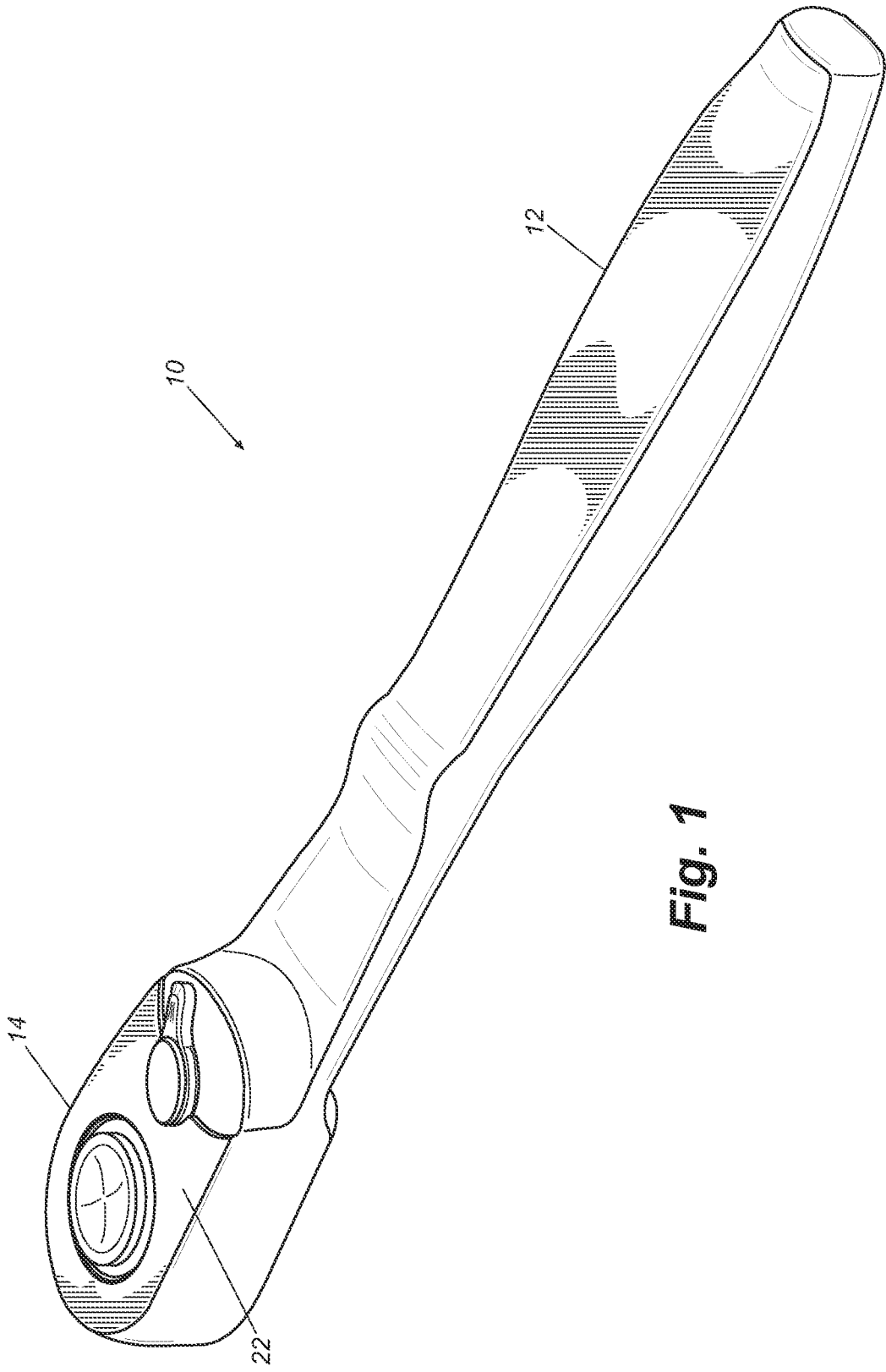
**Apex Brands, Inc.**

**Patent Attorneys for the Applicant/Nominated Person**

**SPRUSON & FERGUSON**

2017200540 27 Jan 2017

1/18



**Fig. 1**

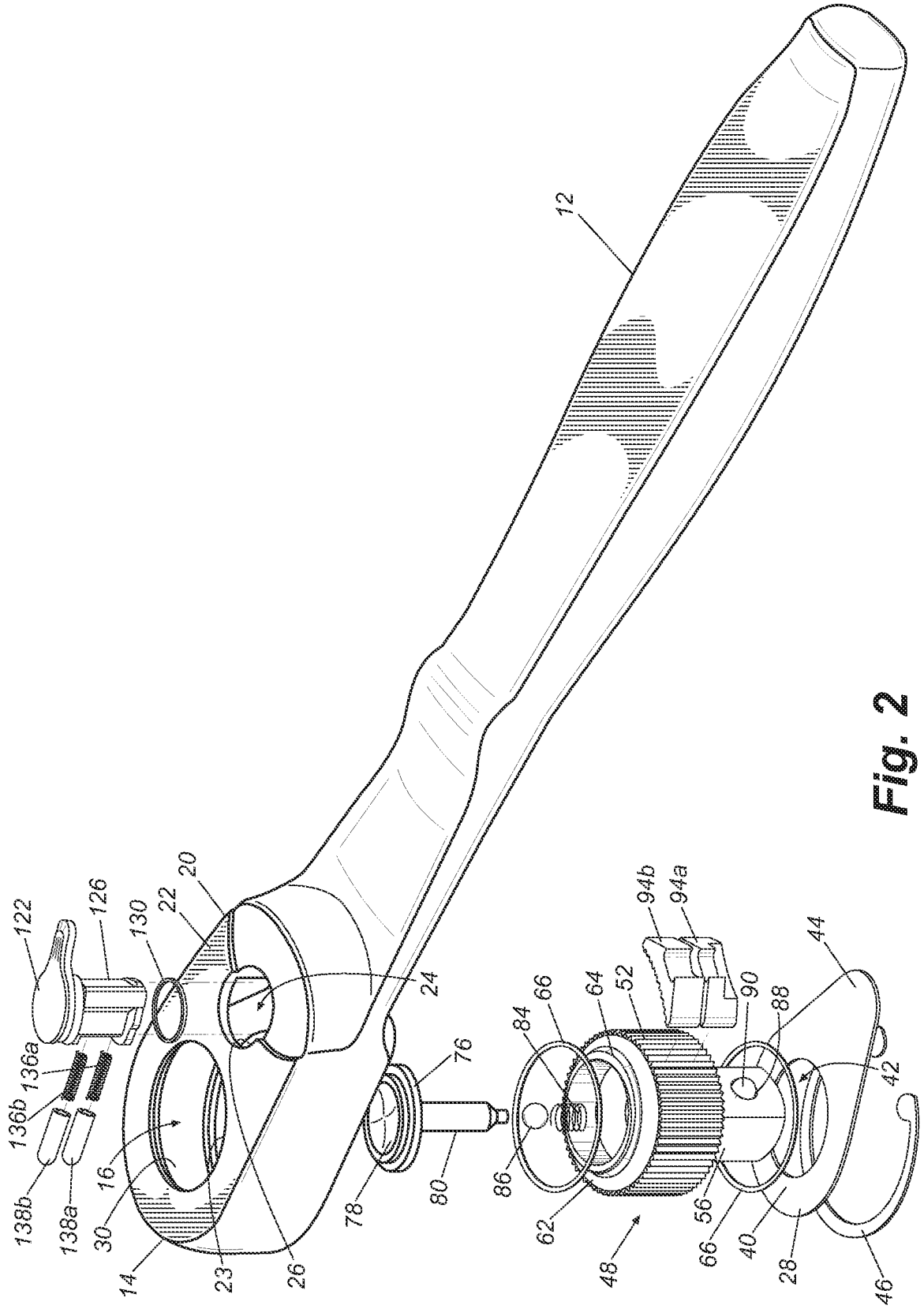


Fig. 2

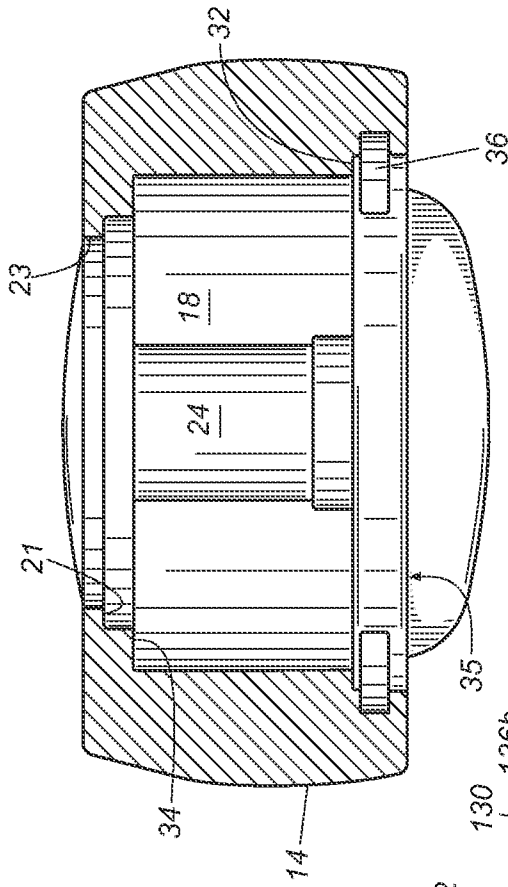


Fig. 3A

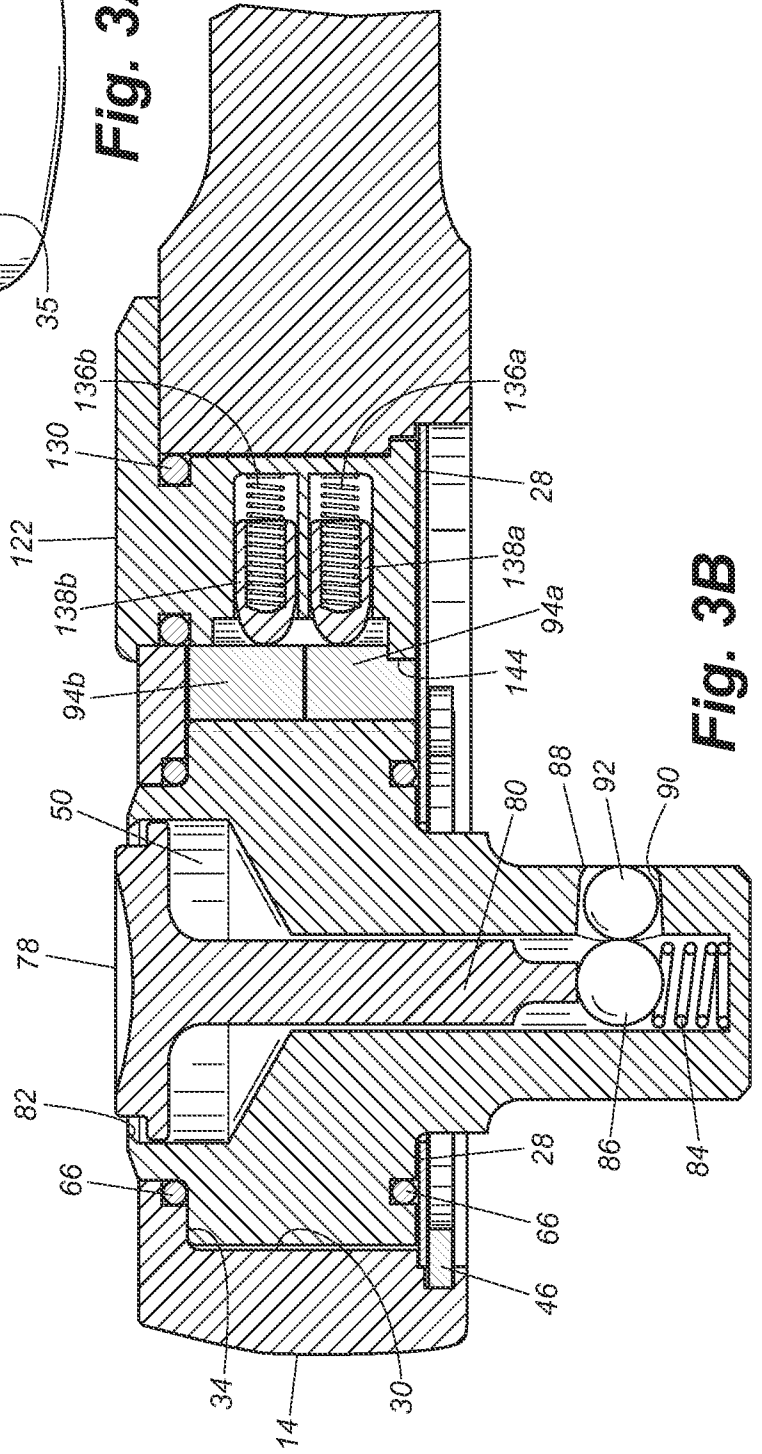
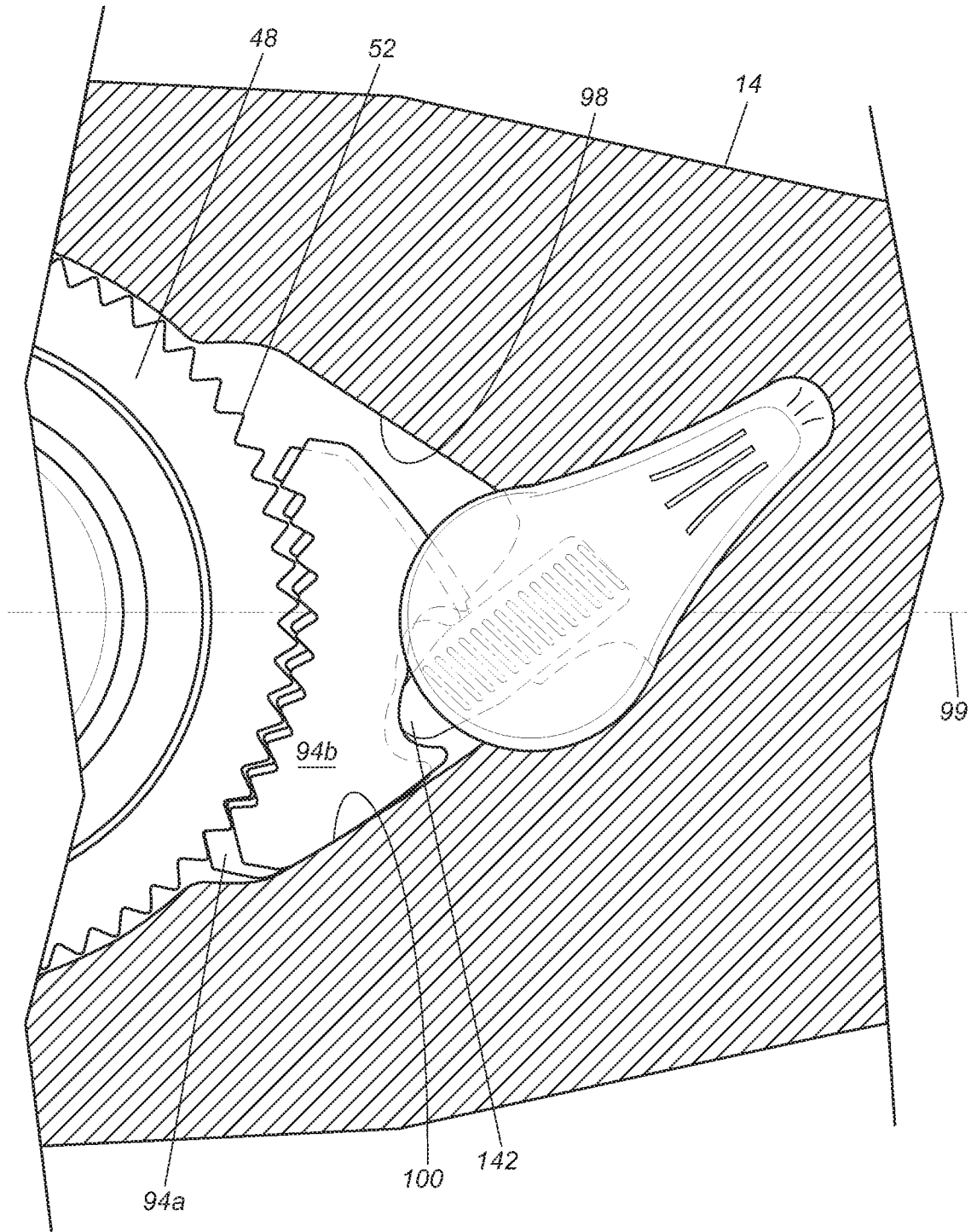
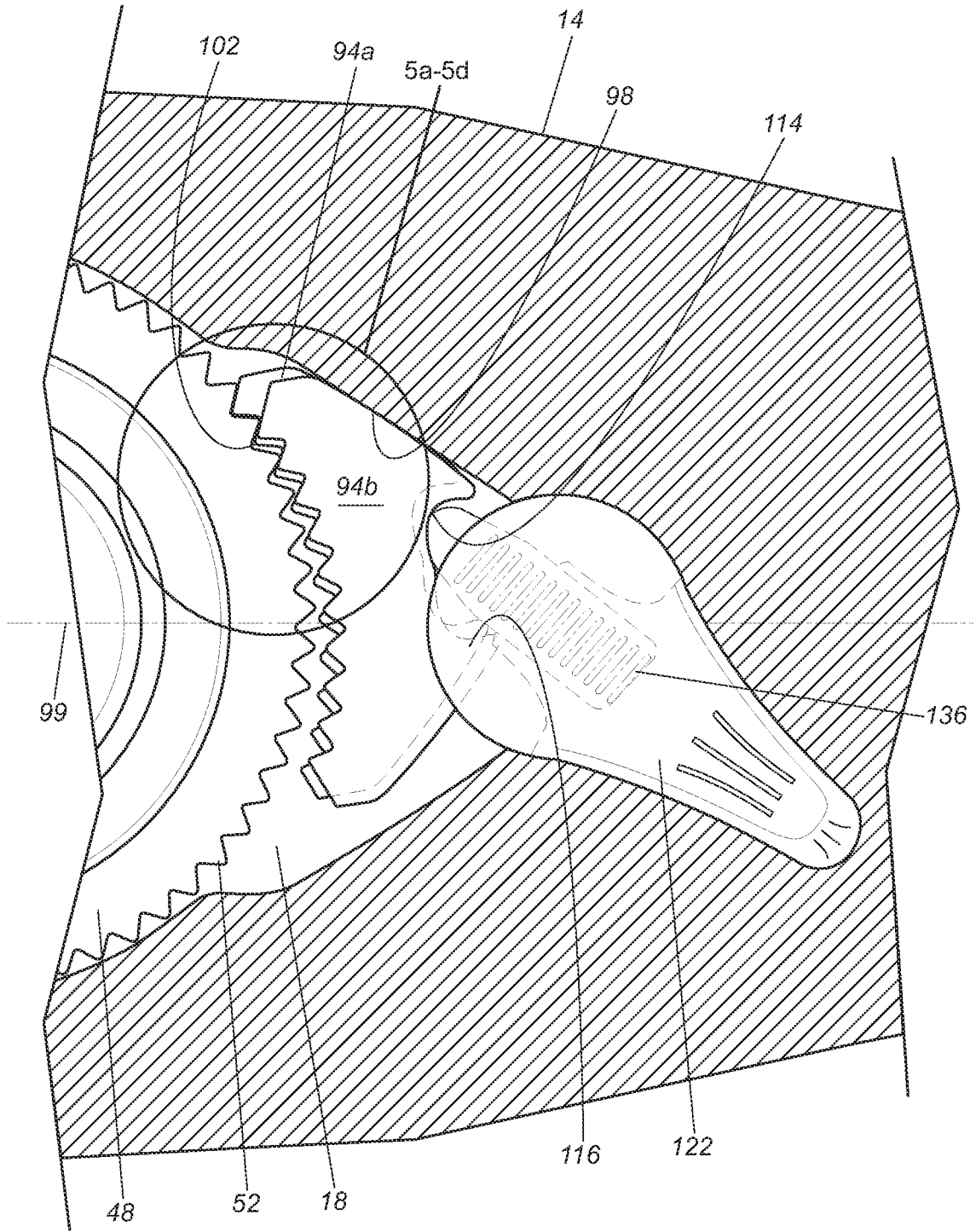


Fig. 3B



**Fig. 4A**

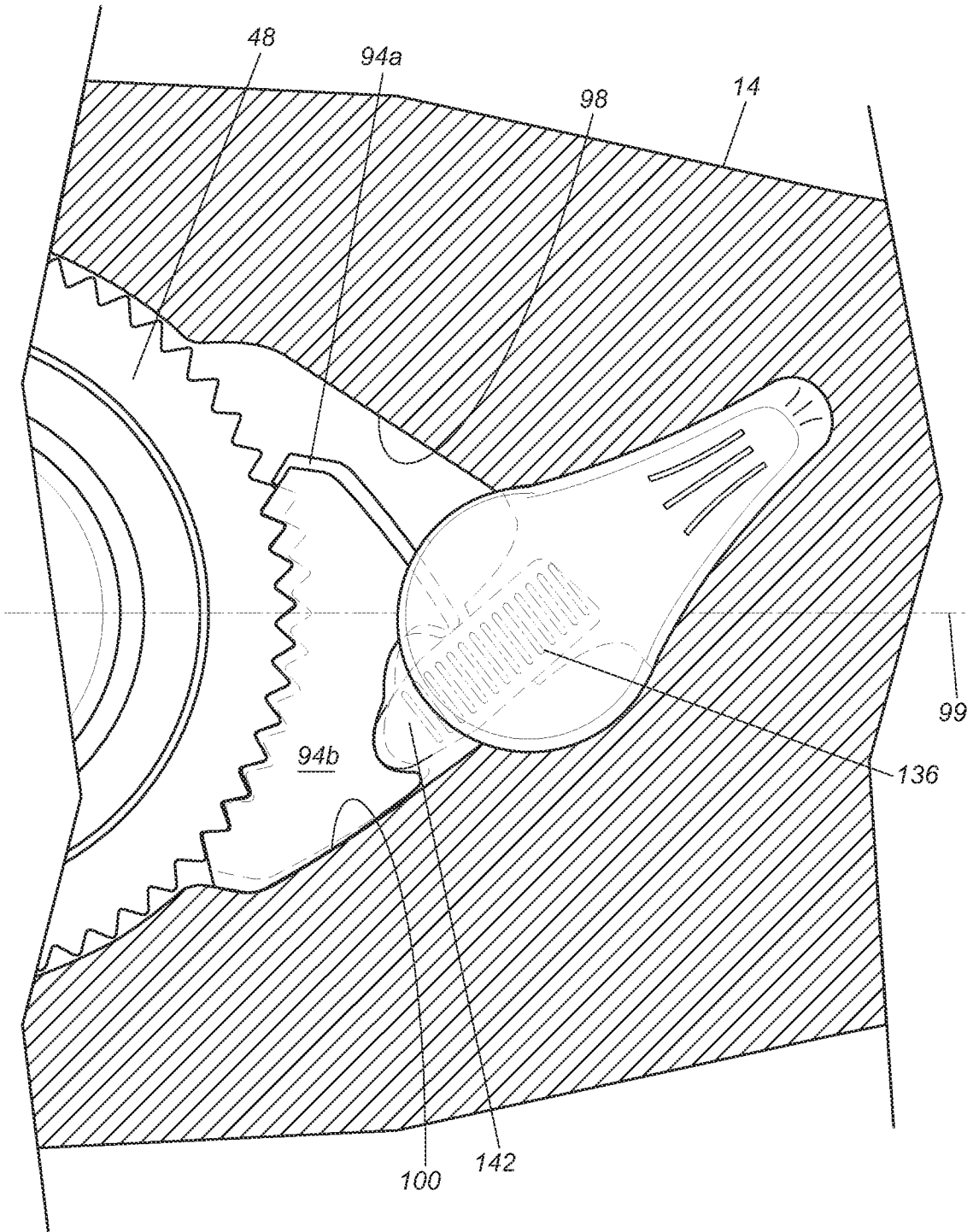




**Fig. 4B**

2017200540 27 Jan 2017

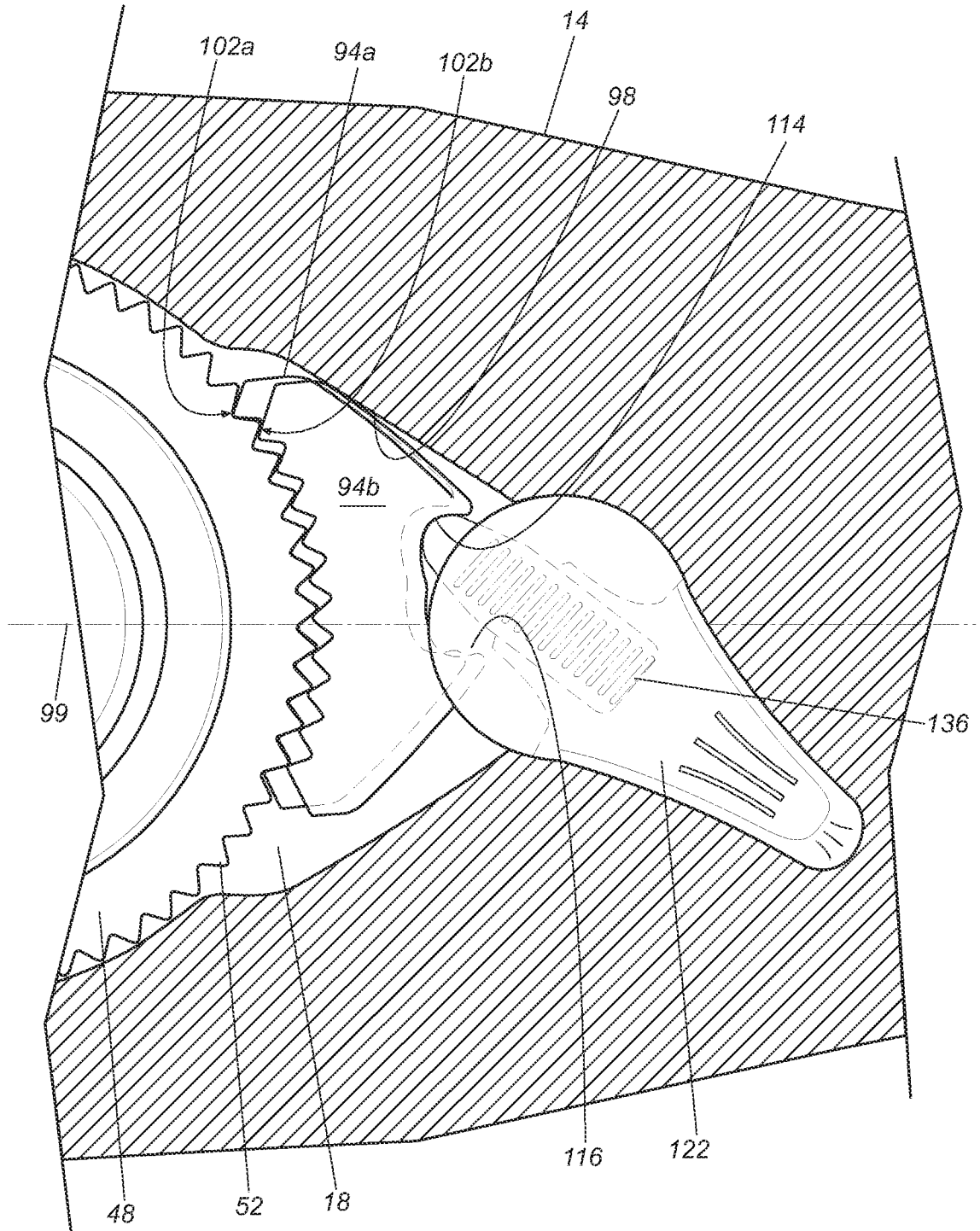
6/18



**Fig. 4C**

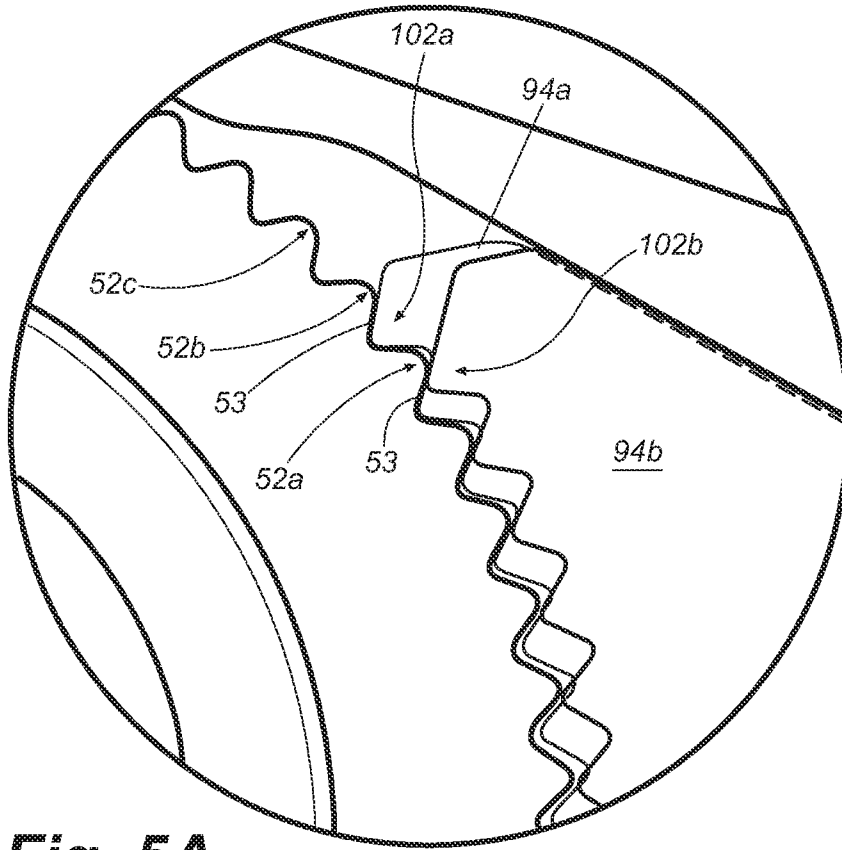
2017200540 27 Jan 2017

7/18

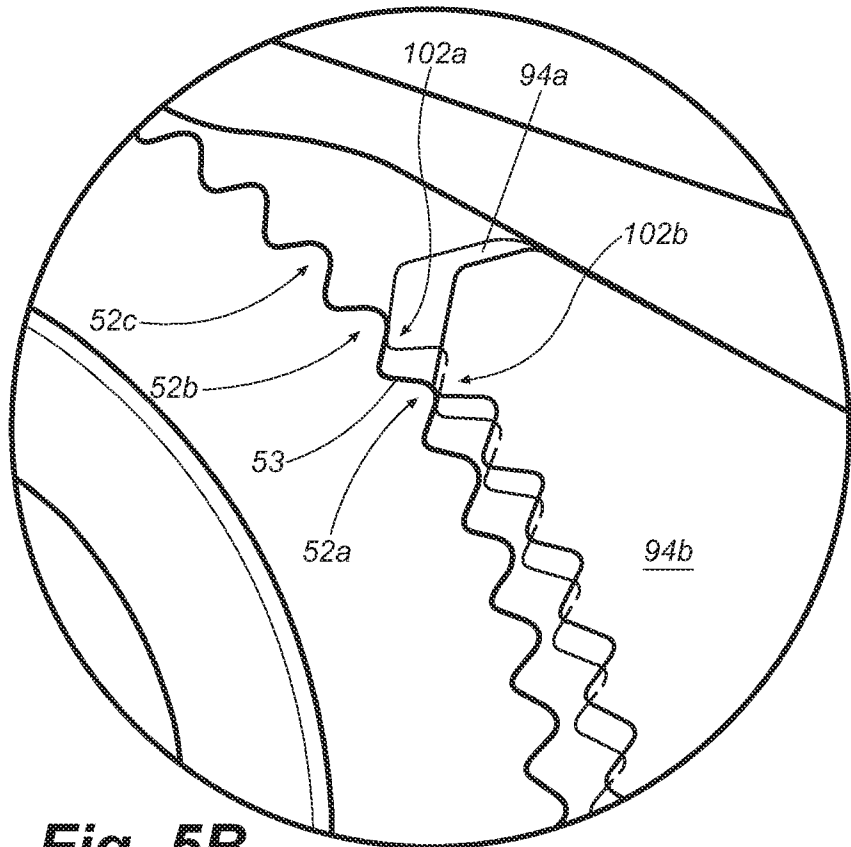


**Fig. 4D**

8/18

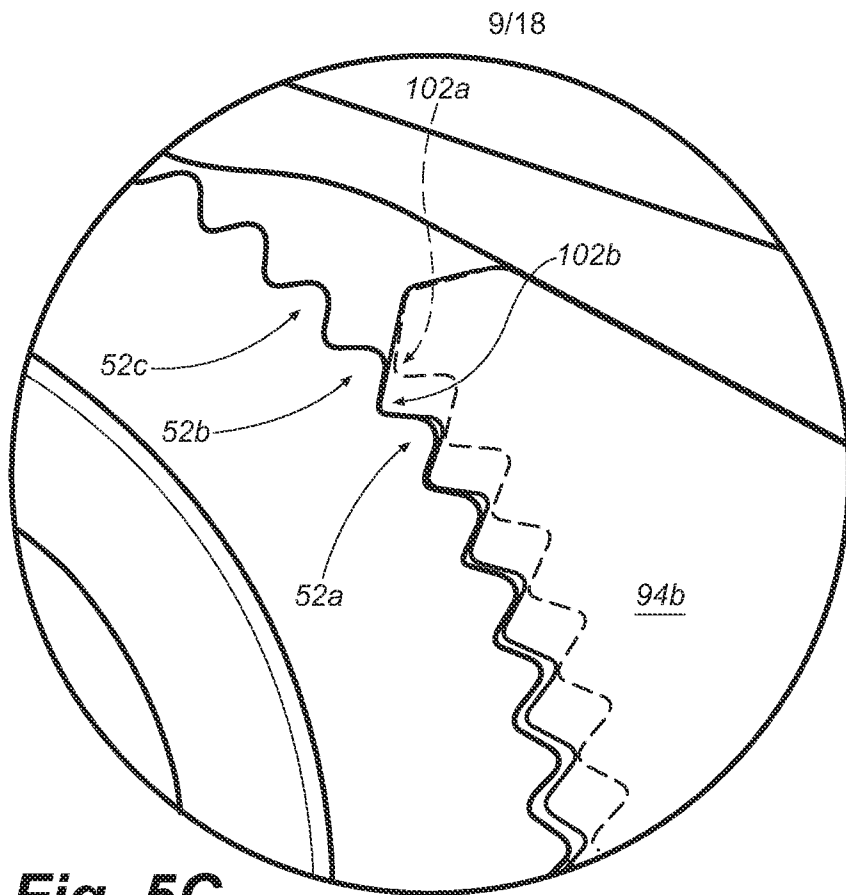


**Fig. 5A**

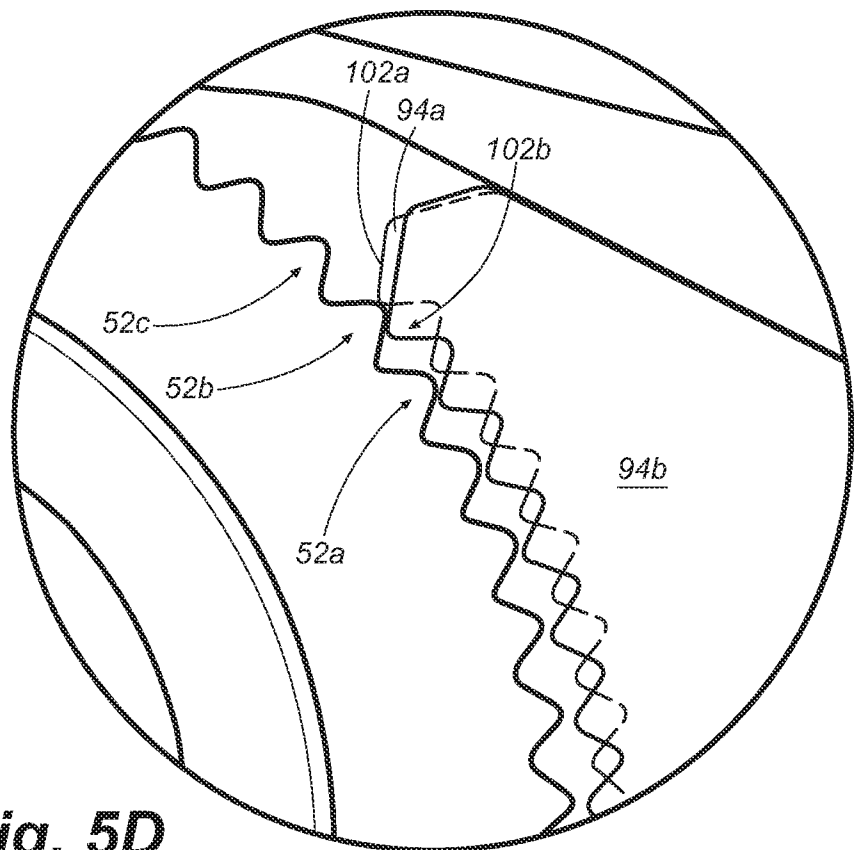


**Fig. 5B**

2017200540 27 Jan 2017

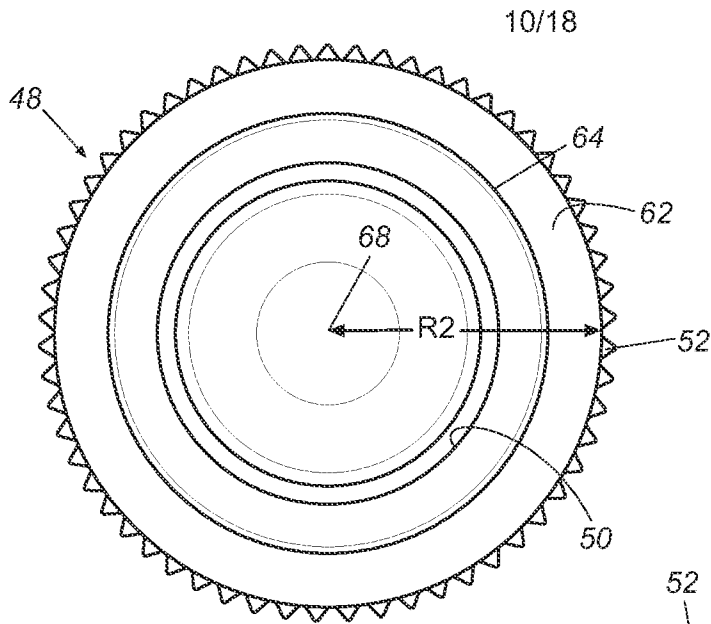


**Fig. 5C**

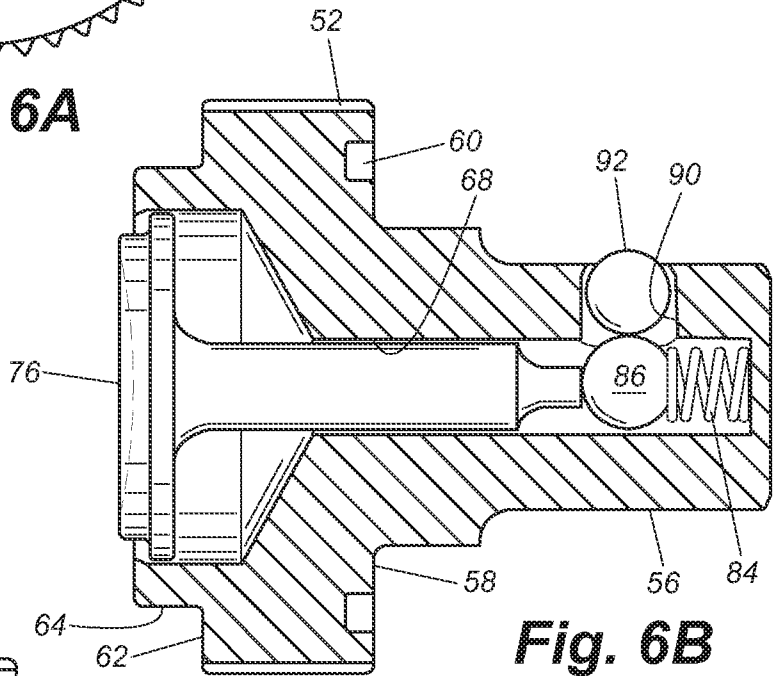


**Fig. 5D**

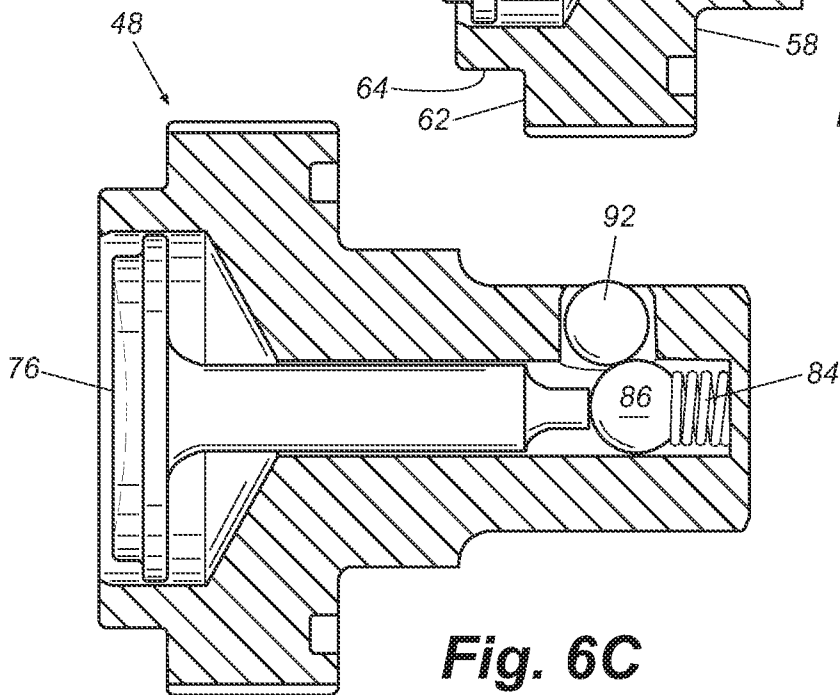
2017200540 27 Jan 2017



**Fig. 6A**

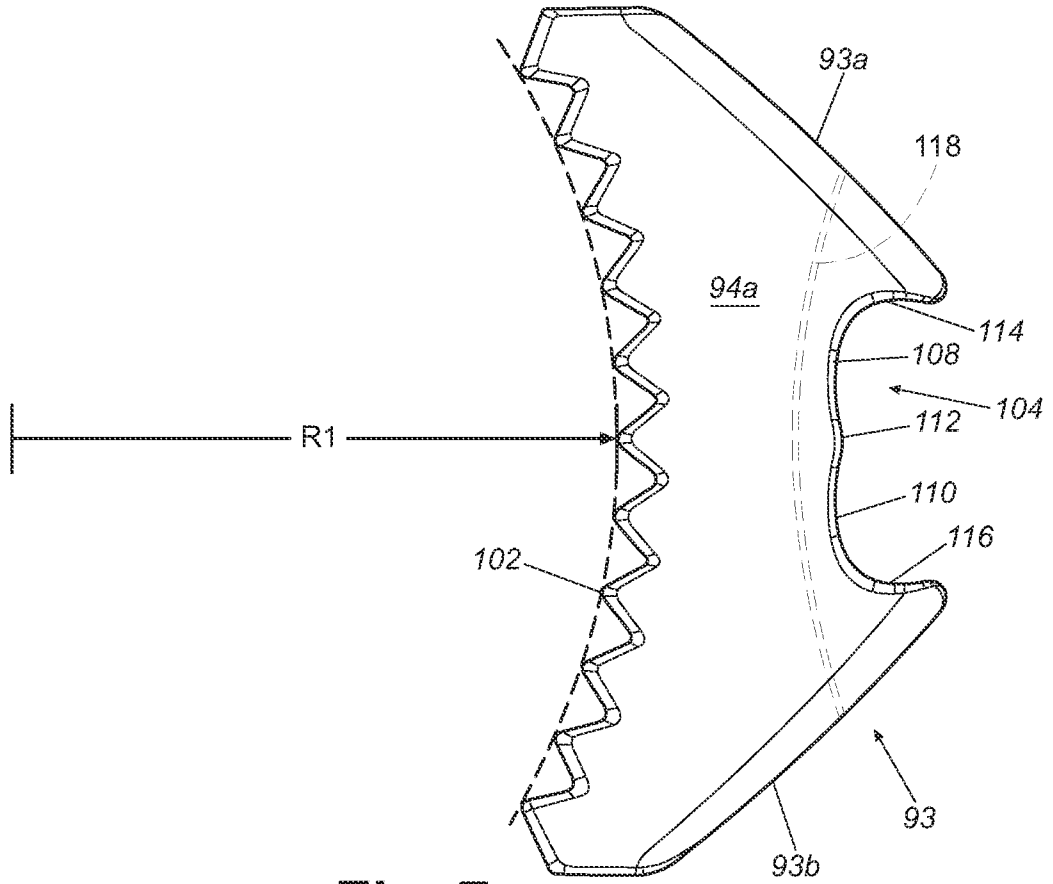


**Fig. 6B**

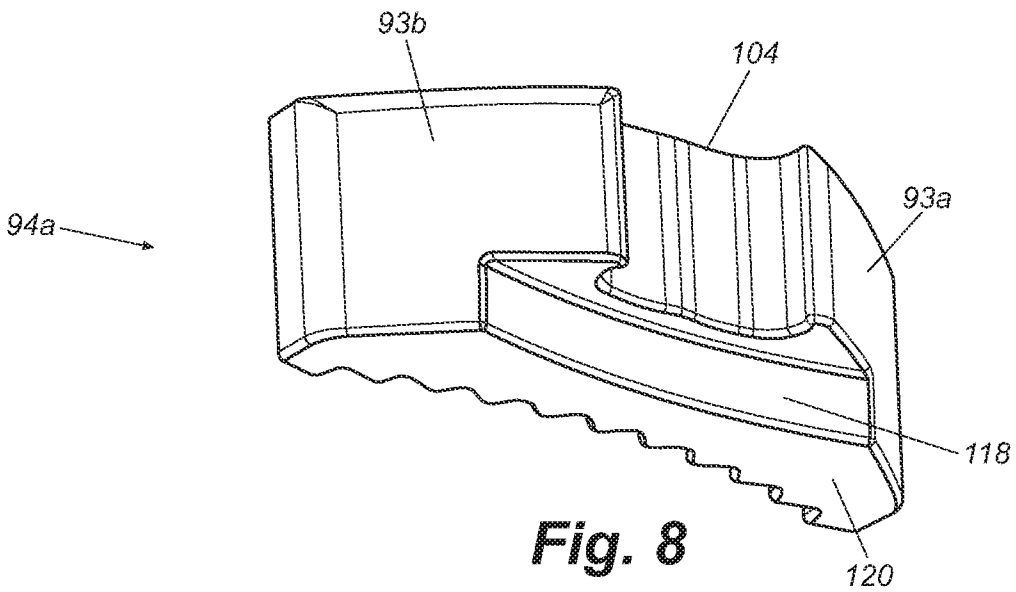


**Fig. 6C**

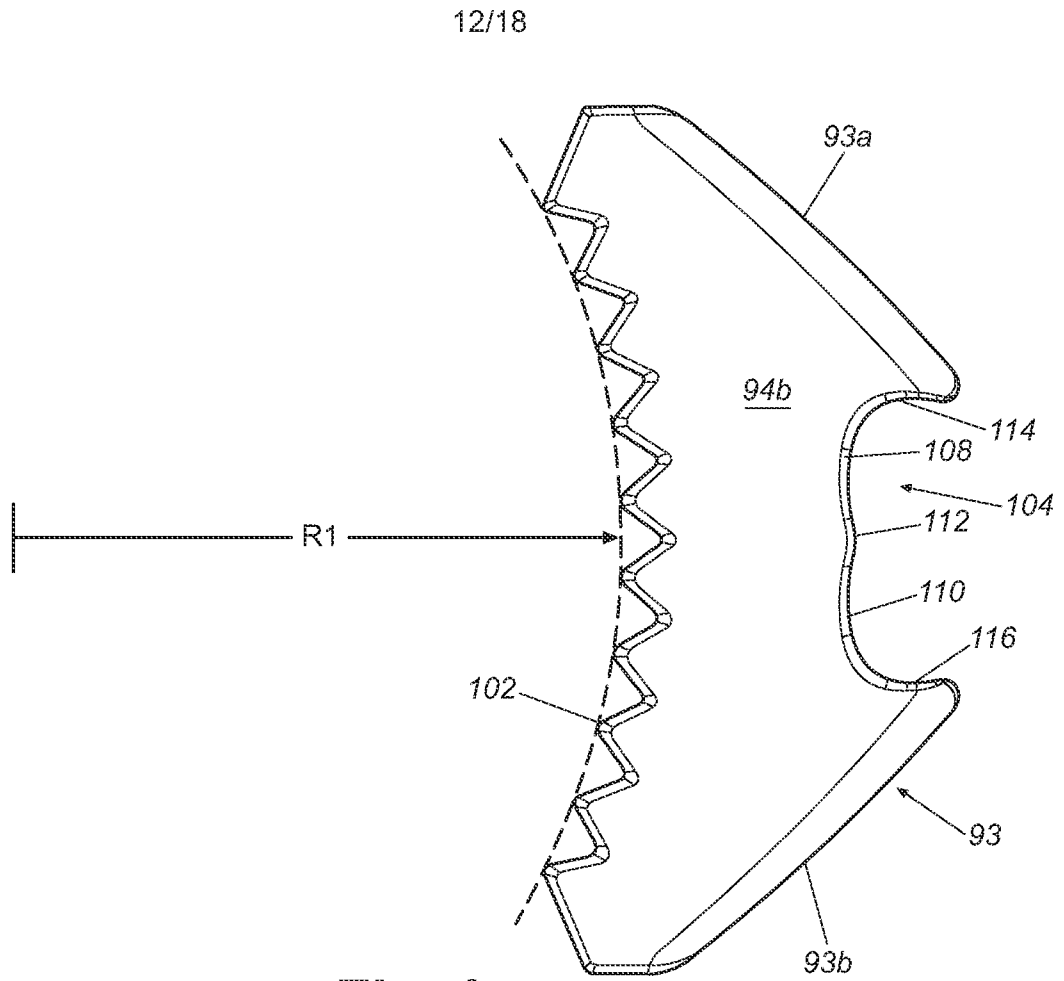
11/18



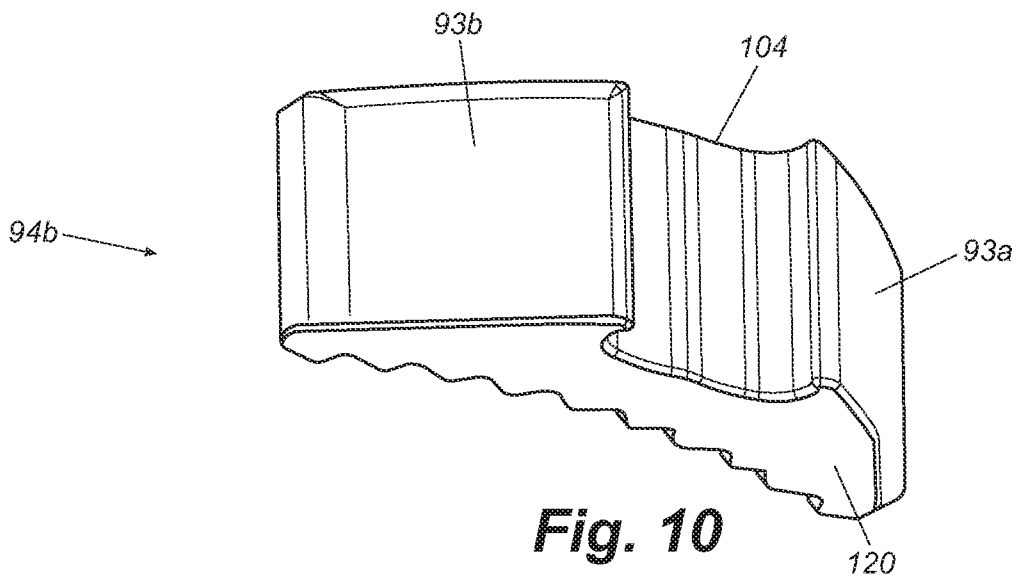
**Fig. 7**



**Fig. 8**

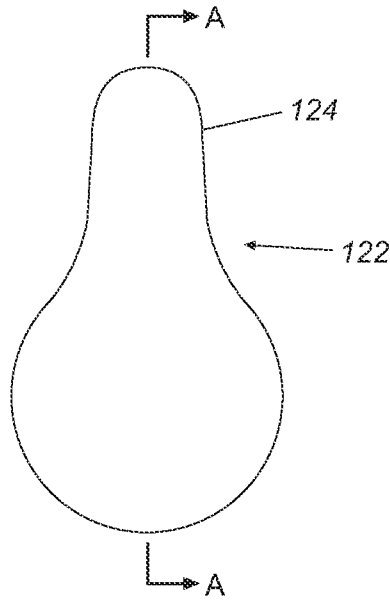


**Fig. 9**

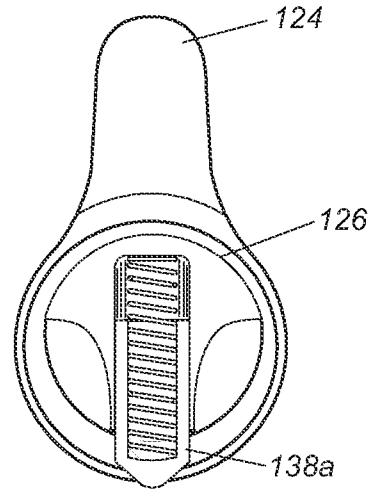


**Fig. 10**

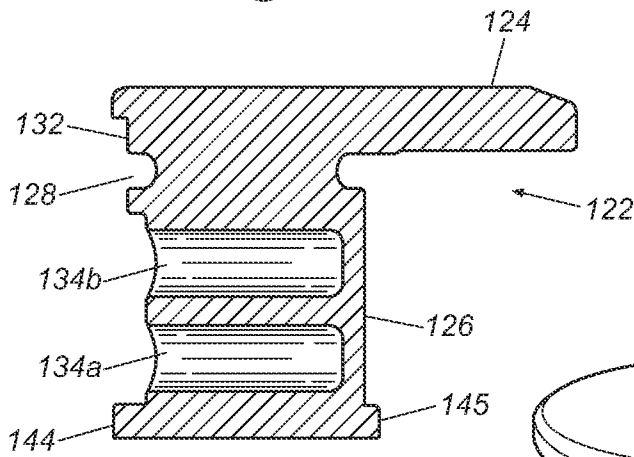




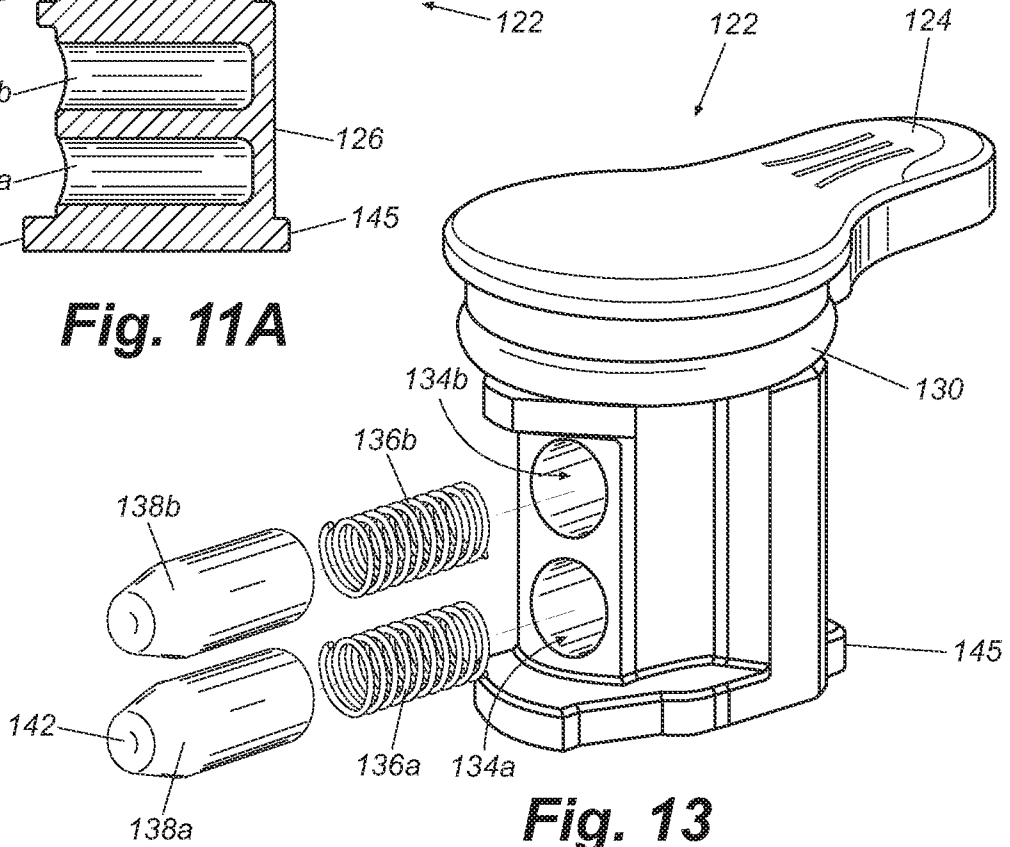
**Fig. 11**



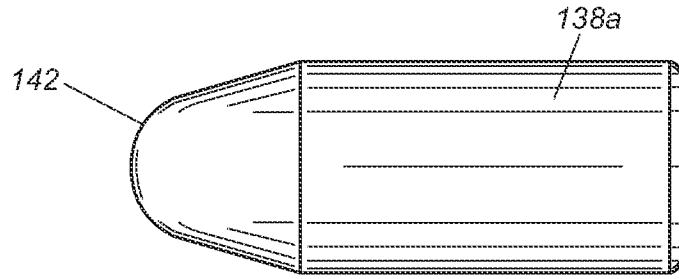
**Fig. 12**



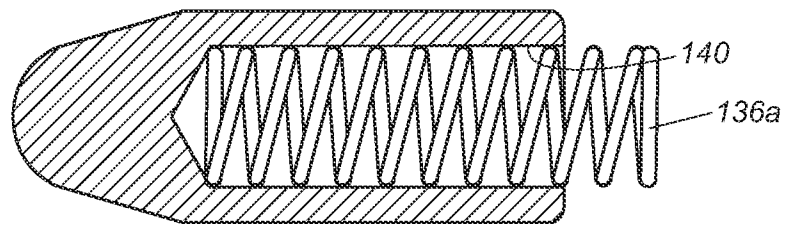
**Fig. 11A**



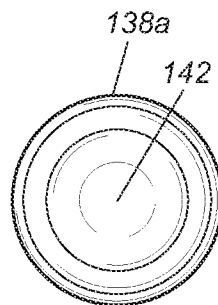
**Fig. 13**



**Fig. 14**



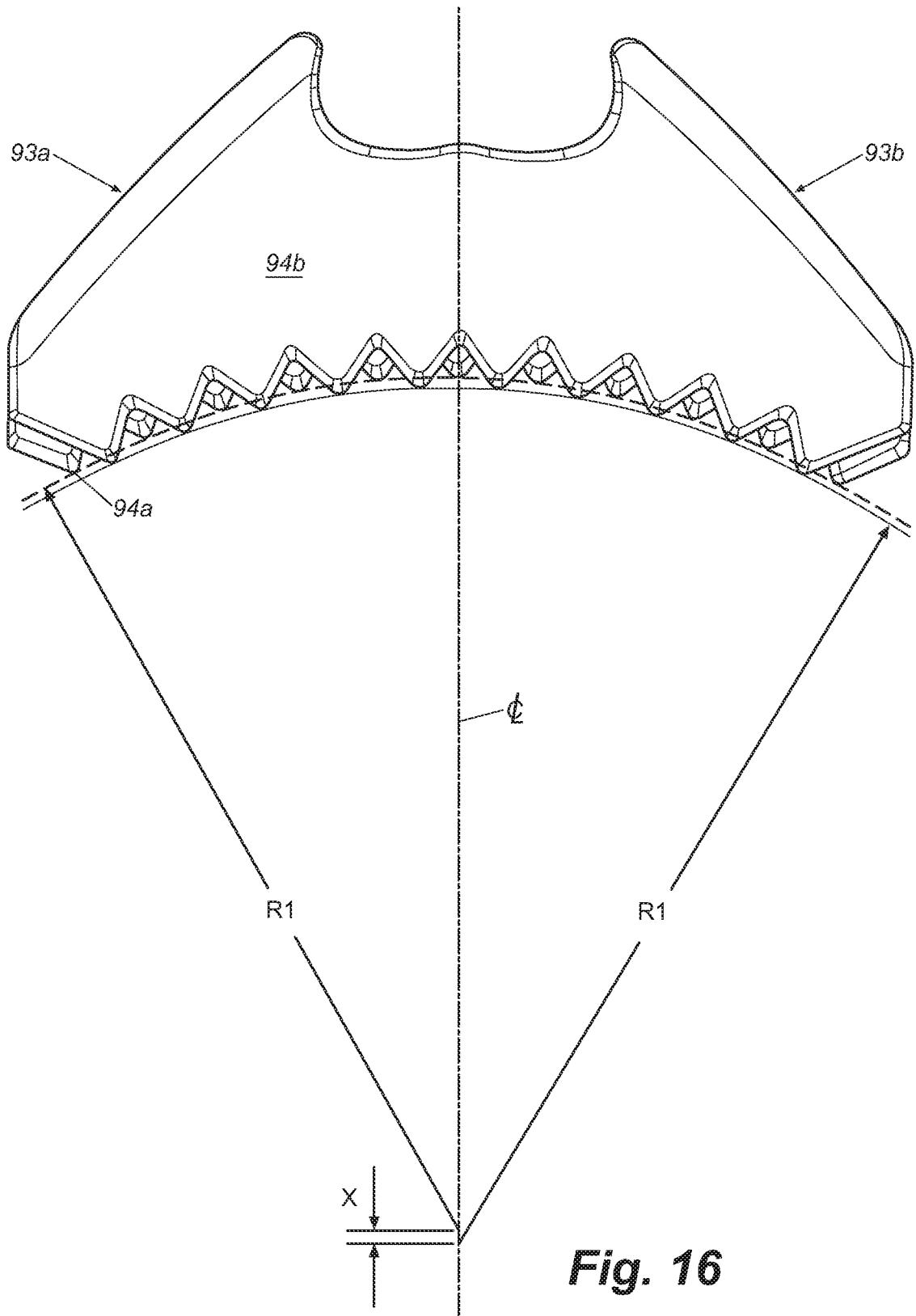
**Fig. 14A**



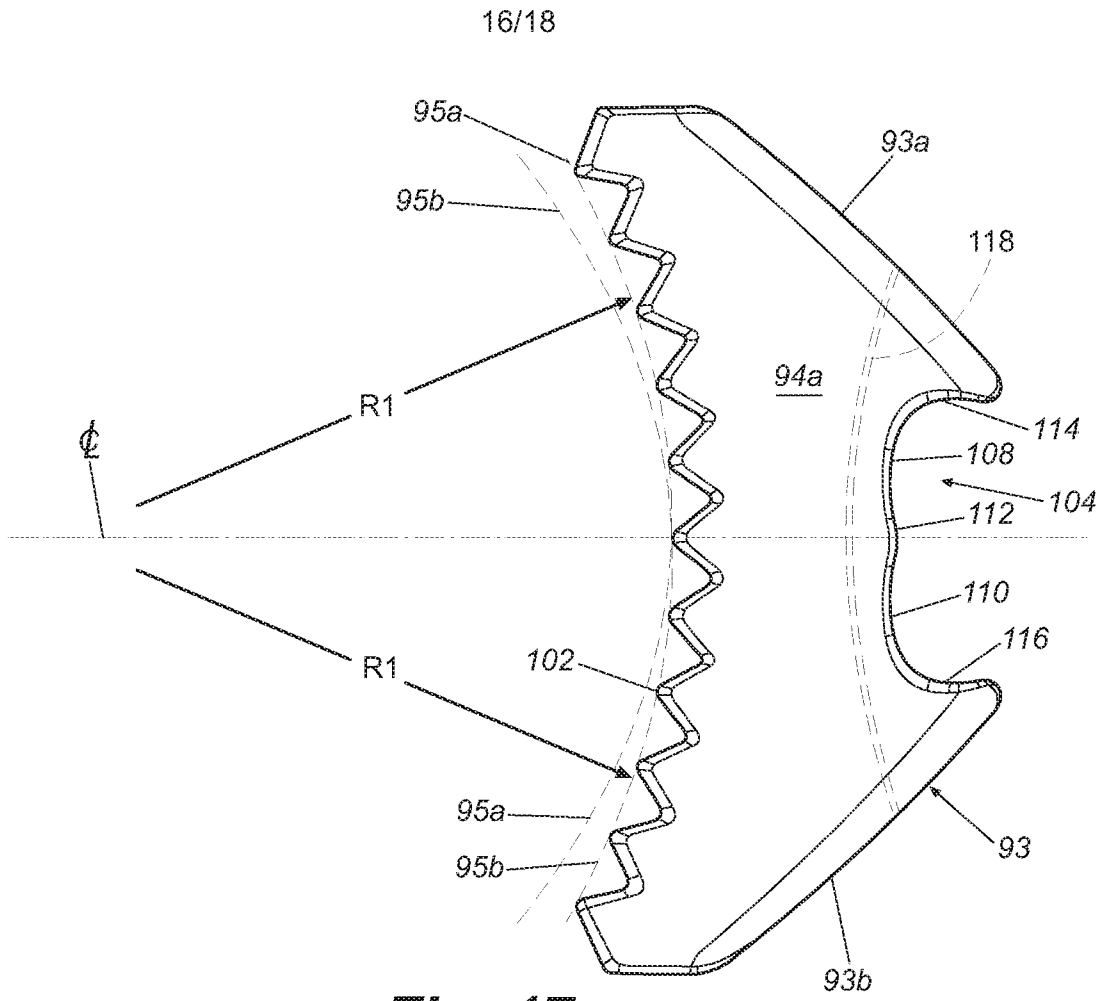
**Fig. 15**

2017200540 27 Jan 2017

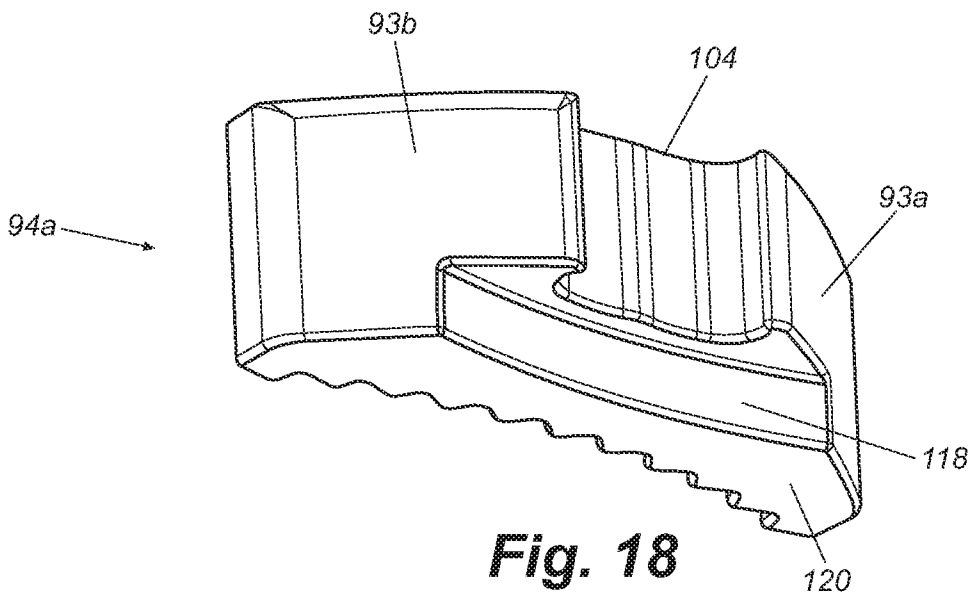
15/18



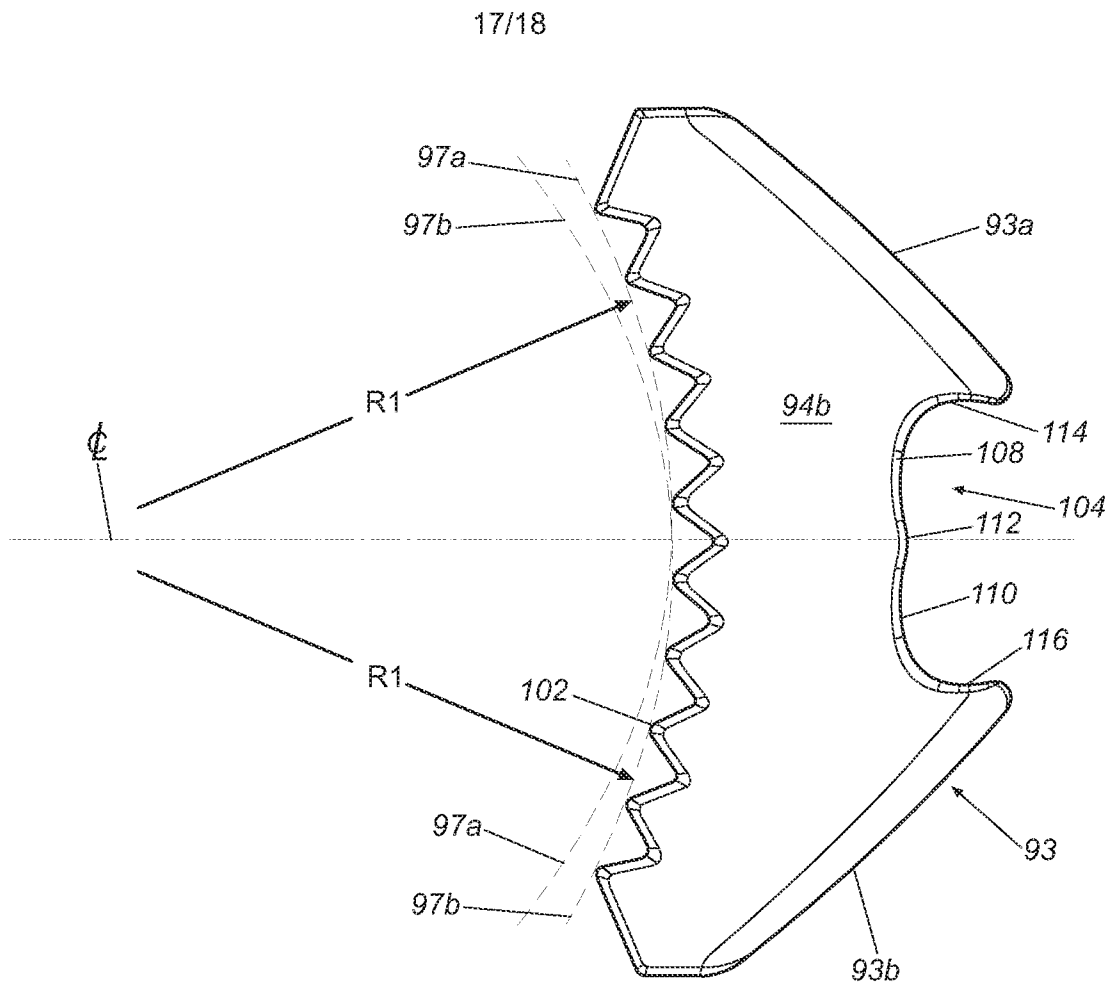
**Fig. 16**



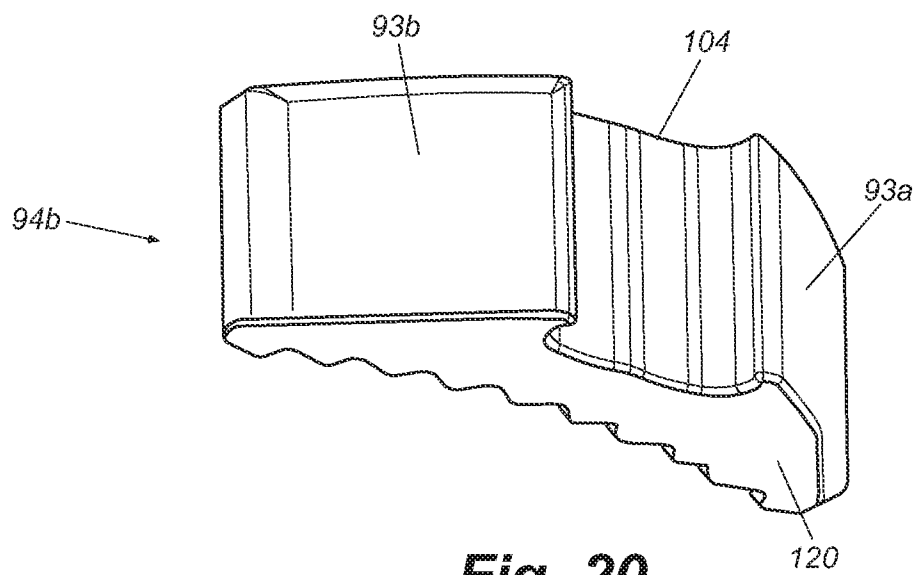
**Fig. 17**



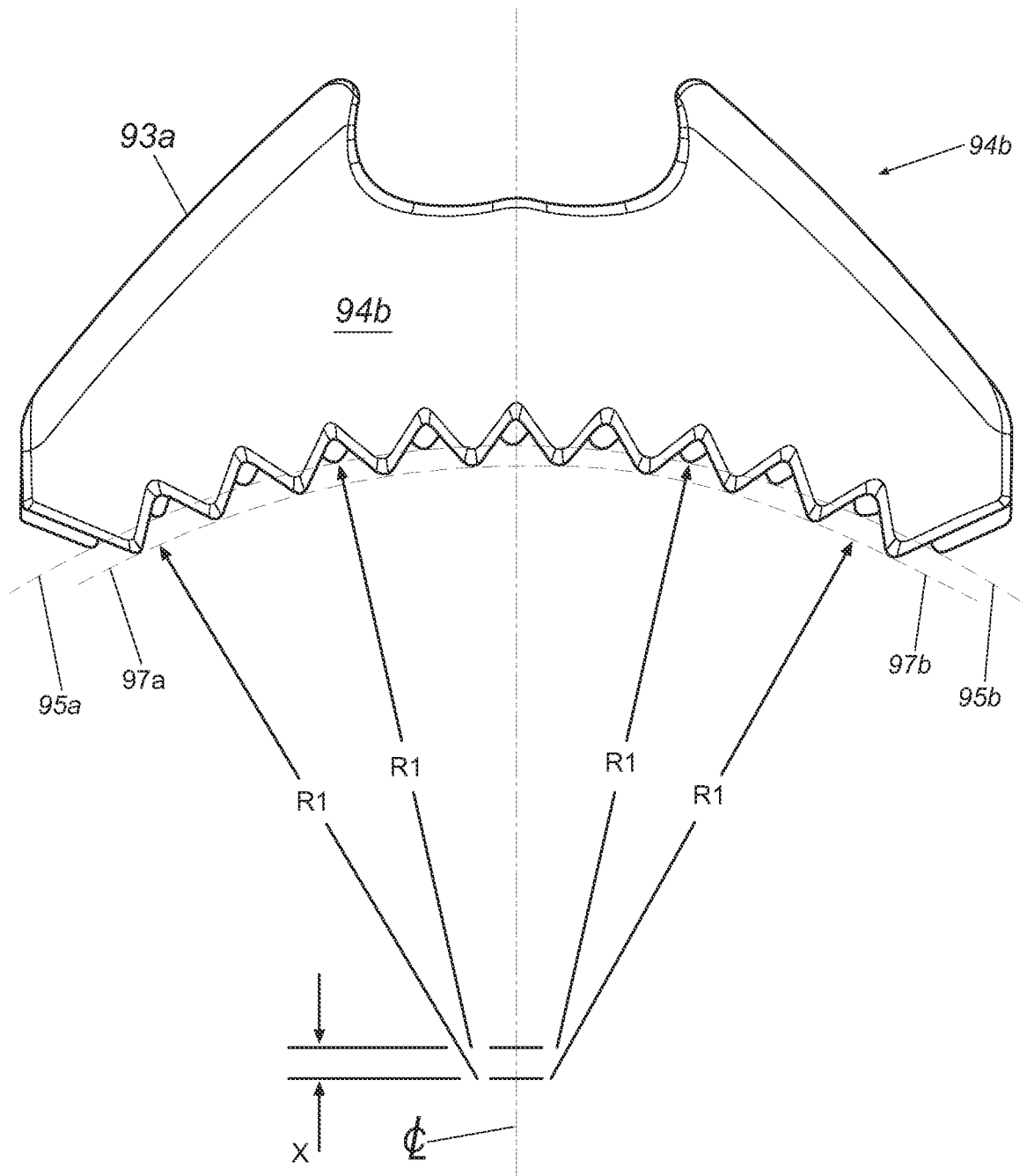
**Fig. 18**



**Fig. 19**



**Fig. 20**



**Fig. 21**