



(12) **DEMANDE DE BREVET CANADIEN
CANADIAN PATENT APPLICATION**

(13) **A1**

(86) Date de dépôt PCT/PCT Filing Date: 2018/09/28
(87) Date publication PCT/PCT Publication Date: 2020/04/02
(85) Entrée phase nationale/National Entry: 2021/03/15
(86) N° demande PCT/PCT Application No.: FI 2018/050702
(87) N° publication PCT/PCT Publication No.: 2020/065123

(51) Cl.Int./Int.Cl. *E04B 1/14* (2006.01),
E04B 1/61 (2006.01), *E04C 2/38* (2006.01),
E04D 3/366 (2006.01), *E04B 1/38* (2006.01)
(71) Demandeur/Applicant:
CC WIZARD OY, FI
(72) Inventeur/Inventor:
KINNUNEN, JORMA, FI
(74) Agent: ANDREWS ROBICHAUD

(54) Titre : SYSTEME ET PROCEDE DE CONSTRUCTION
(54) Title: A BUILDING SYSTEM AND METHOD

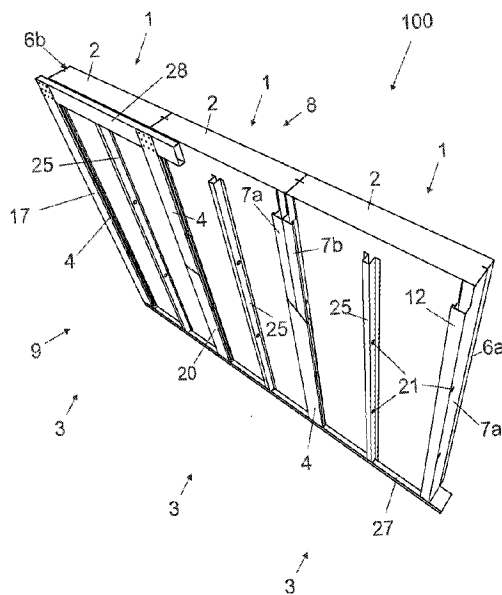

Fig. 1

(57) **Abrégé/Abstract:**

A building system and a method for constructing a building, the system (100) comprising plurality of prefabricated elements (1), the element (1) comprising: a self-supporting insulation panel (2) comprising a rigid insulation material, - a metal frame (3), comprising a pair of sub-frames. The length of the sub-frame (7a, 7b) has a cross-section comprising an attaching arm (10) extending along the corresponding edge surface (6a, 6b), and an intruding section (11) arranged in the attaching arm (10), the intruding section (11) intruding into the insulation element (5). A box-type structure (12) is arranged distally from the intruding section (11) and comprising a closed or partly open construction. The building system further comprises a connecting element (4), having a cross-section basically a shape of a U-profile. The connecting element (4) is arranged on sub-frames (7a, 7b) of two adjacent elements (1).

(12) INTERNATIONAL APPLICATION PUBLISHED UNDER THE PATENT COOPERATION TREATY (PCT)

(19) World Intellectual Property
Organization

International Bureau

(43) International Publication Date
02 April 2020 (02.04.2020)(10) International Publication Number
WO 2020/065123 A1

(51) International Patent Classification:

E04B 1/14 (2006.01) *E04D 3/366* (2006.01)
E04B 1/61 (2006.01) *E04B 1/38* (2006.01)
E04C 2/38 (2006.01)

(21) International Application Number:

PCT/FI2018/050702

(22) International Filing Date:

28 September 2018 (28.09.2018)

(25) Filing Language:

English

(26) Publication Language:

English

(71) Applicant: **CC WIZARD OY** [FI/FI]; Maamichentie 5, 13430 Hämeenlinna (FI).(72) Inventor: **KINNUNEN, Jorma**; Maamichentie 5, 13430 Hämeenlinna (FI).(74) Agent: **PAPULA OY**; P.O Box 981, 00101 Helsinki (FI).

(81) Designated States (unless otherwise indicated, for every kind of national protection available): AE, AG, AL, AM, AO, AT, AU, AZ, BA, BB, BG, BH, BN, BR, BW, BY, BZ, CA, CH, CL, CN, CO, CR, CU, CZ, DE, DJ, DK, DM, DO, DZ, EC, EE, EG, ES, FI, GB, GD, GE, GH, GM, GT, HN, HR, HU, ID, IL, IN, IR, IS, JO, JP, KE, KG, KH, KN, KP, KR, KW, KZ, LA, LC, LK, LR, LS, LU, LY, MA, MD, ME, MG, MK, MN, MW, MX, MY, MZ, NA, NG, NI, NO, NZ,

OM, PA, PE, PG, PH, PL, PT, QA, RO, RS, RU, RW, SA, SC, SD, SE, SG, SK, SL, SM, ST, SV, SY, TH, TJ, TM, TN, TR, TT, TZ, UA, UG, US, UZ, VC, VN, ZA, ZM, ZW.

(84) Designated States (unless otherwise indicated, for every kind of regional protection available): ARIPO (BW, GH, GM, KE, LR, LS, MW, MZ, NA, RW, SD, SL, ST, SZ, TZ, UG, ZM, ZW), Eurasian (AM, AZ, BY, KG, KZ, RU, TJ, TM), European (AL, AT, BE, BG, CH, CY, CZ, DE, DK, EE, ES, FI, FR, GB, GR, HR, HU, IE, IS, IT, LT, LU, LV, MC, MK, MT, NL, NO, PL, PT, RO, RS, SE, SI, SK, SM, TR), OAPI (BF, BJ, CF, CG, CI, CM, GA, GN, GQ, GW, KM, ML, MR, NE, SN, TD, TG).

Declarations under Rule 4.17:

- as to applicant's entitlement to apply for and be granted a patent (Rule 4.17(ii))
- of inventorship (Rule 4.17(iv))

Published:

- with international search report (Art. 21(3))

(54) Title: A BUILDING SYSTEM AND METHOD

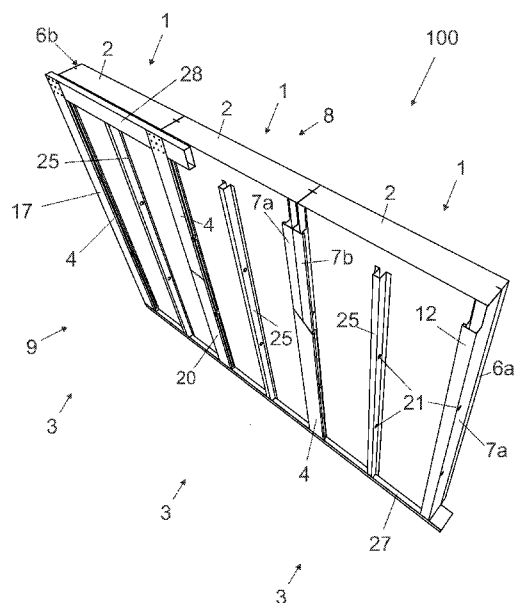

Fig. 1

(57) Abstract: A building system and a method for constructing a building, the system (100) comprising plurality of prefabricated elements (1), the element (1) comprising: a self-supporting insulation panel (2) comprising a rigid insulation material, - a metal frame (3), comprising a pair of sub-frames. The length of the sub-frame (7a, 7b) has a cross-section comprising an attaching arm (10) extending along the corresponding edge surface (6a, 6b), and an intruding section (11) arranged in the attaching arm (10), the intruding section (11) intruding into the insulation element (5). A box-type structure (12) is arranged distally from the intruding section (11) and comprising a closed or partly open construction. The building system further comprises a connecting element (4), having a cross-section basically a shape of a U-profile. The connecting element (4) is arranged on sub-frames (7a, 7b) of two adjacent elements (1).



WO 2020/065123 A1

A BUILDING SYSTEM AND METHOD

BACKGROUND

The invention relates to a building system for constructing a building.

5

The invention further relates to a method for constructing a building.

10 It is known to build buildings based on a metal frame construction. The metal frame may give advantages in greater strength, fire resistance and architectural design flexibility, for instance. A thermal insulation layer is attached to the metal frame either outside of the metal frame or between metal profiles that form the metal frame.

15

A problem with the metal frame constructions is that they usually are based on idea just to replace a wooden frame construction by metal components. The building cost is relatively high because of the costly materials and the skilled crew and special equipment are needed to assemble the building. Therefore, the construction technique is generally considered unsuitable for single family residence building.

20

BRIEF DESCRIPTION

25 Viewed from a first aspect, there can be provided a building system for constructing a building, the system comprising: plurality of prefabricated elements, the element comprising: a self-supporting insulation panel comprising a rigid insulation material and having two straight and parallel edge surfaces, and an outer and inner surfaces, a metal frame, comprising a pair of sub-frames, a first sub-frame attached to a first edge surface and a second sub-frame attached to a second edge surface of the insulation panel, the sub-frame extending along the length of the insulation panel, the length of the sub-frame having a

30

35

cross-section comprising an attaching arm extending along the corresponding edge surface, and an intruding section arranged in the attaching arm and in an angle respect to that, the intruding section intruding into the insulation element, and a box-type structure arranged distally from the intruding section and comprising walls and corners constituting a closed or partly open construction, the box-like structure extending from the attaching arm and being arranged on the outer surface or on the inner surface of the insulation panel, the building system further comprising a connecting element, being at least essentially as long as the sub-frame and having a cross-section comprising two arms and a connecting section connecting said two arms, the cross-section having basically a shape of an U-profile, the connecting element, in use, being arranged on sub-frames of two adjacent elements, said arms being situated on opposite side of the two sub-frames and keeping together said sub-frames of adjacent elements.

20 Thereby a building system easy to assemble may be achieved.

Viewed from a further aspect, there can be provided a method for constructing a building, the method comprising: connecting two of prefabricated elements described above by contacting their opposite edge surfaces to each other, attaching the sub-frames of said prefabricated elements to each other, arranging the connecting element according to any of the preceding claims on said sub-frames, and attaching said connecting element to said sub-frames.

Thereby a method that produces a supporting structure and insulated structure quickly and easily may be achieved.

35 The arrangement and the method are characterised by what is stated in the characterising parts of the independent

claims. Some other embodiments are characterised by what is stated in the other claims. Inventive embodiments are also disclosed in the specification and drawings of this patent application. The inventive content of the patent application may also be defined in other ways than defined in the following claims. The inventive content may also be formed of several separate inventions, especially if the invention is examined in the light of expressed or implicit sub-tasks or in view of obtained benefits or benefit groups. Some of the definitions contained in the following claims may then be unnecessary in view of the separate inventive ideas. Features of the different embodiments of the invention may, within the scope of the basic inventive idea, be applied to other embodiments.

15 **BRIEF DESCRIPTION OF FIGURES**

Some embodiments illustrating the present disclosure are described in more detail in the attached drawings, in which

20 Figure 1 is a schematic view of detail of a building system for constructing a building,

Figures 2a - 2h are schematic top views of embodiments of sub-frames of the arrangement,

25 Figures 3a - 3g are schematic top views of embodiments of connecting elements of the arrangement, and

30 Figure 4 is a schematic top view of an assembly method step of the arrangement.

In the figures, some embodiments are shown simplified for the sake of clarity. Similar parts are marked with the same reference numbers in the figures.

DETAILED DESCRIPTION

Figure 1 is a schematic view of detail of a building system for constructing a building. The system 100 comprises plurality of prefabricated elements 1 that are connected together for creating a wall, a floor, a roof or a ceiling of a building. Thus, in an embodiment, the prefabricated element 1 is a wall element. In another embodiment, the prefabricated element 1 is a floor element. In a third embodiment, the prefabricated element 1 is a ceiling element.

The element 1 comprises a self-supporting insulation panel 2 comprising a rigid thermal insulation material and having two straight and parallel edge surfaces 6a, 6b, and an outer and inner surfaces 8, 9.

According to an aspect, the material of the insulation panel 2 comprises at least one of the following materials: polyisocyanurate (PIR), polyurethane (PUR) and extruded polystyrene (XPS), or another rigid insulation material. In an embodiment, the insulation panel 2 has a homogenous structure and material, e.g. rigid foam insulation material, from its outer surface to its inner surface.

In an embodiment, the insulation panel 2 has a shape of rectangle. The dimensions of the element 1 may be e.g. 1200 mm (width) x 3000 mm (height). According to an idea, the width of the element is selected in range of 300 mm to 2400 mm, and the height 600 mm to 15000 mm. In an embodiment, the thickness of the insulation panel is selected in range of 100 mm to 300 mm, and the thickness of the insulation panel is uniform from its first edge surface to another edge surface.

The element 1 further comprises a metal frame 3 that includes a pair of sub-frames: a first sub-frame 7a attached

to a first edge surface 6a and a second sub-frame 7b attached to a second edge surface 6b of the insulation panel 2. In an embodiment, the sub-frame 7a, 7b extends along the entire length of the insulation panel 2, i.e. the length of the sub-frame is 100 % of length of the insulation panel. However, said length may be essentially more; in an embodiment the length of the insulation panel 2 is 80 - 99 % of the length of the sub-frame 7a, 7b.

10 In still another embodiment, the sub-frame 7a, 7b is essentially longer than the insulation panel 2, such that the metal frame 3 makes it possible to attach two or more insulation panels 2 one on the other.

15 In an embodiment, the insulation panel 2 is essentially longer than the sub-frame 7a, 7b, so that an upper edge of the panel extends above upper ends of the sub-frames. The extension may be e.g. 100 mm - 500 mm, or 20 % of the length of the insulation panel. In an embodiment, the extension has same thickness as the rest of the insulation panel. In another embodiment, the extension is thinner, e.g. 50 mm - 100 mm. An advantage of the extension is that it insulates a roof space above the room, and may also be useful to limit the roof space when applying loose wool, such as loose mineral wool, therein.

In an embodiment, the sub-frame 7a, 7b is of bended sheet metal, thickness of which is in range of 0.5 - 3 mm. Also the auxiliary profile 25 may be of similar material. The material may comprise e.g. steel. In an embodiment, the steel is a strain hardening steel, such as DP780/980. An advantage is that the element stands well against high loads, and loads exceeding yield strength of the material are adsorbed in deformations of the structure. However, the steel may also be selected from group of conventional structural steels.

6

In an embodiment, the sub-frame 7a, 7b is attached to the insulation panel 2 by a glue layer 22. The glue layer may be arranged between an attaching arm 10 of the sub-frame and the corresponding edge surface 6a, 6b, and/or between a box-type structure 12 of the sub-frame and the corresponding surface of the insulation panel. Also the intruding section 11 may be glued to the insulation panel 2.

10 In an embodiment, the metal frame 3 or, at least the surfaces thereof to be glued, have a special surface that enhances adhesion of the glue. Preferably, the strength of the glued joint is defined by cohesion strength of the glue, not adhesion of the glue to the surface. The special
15 surface may be produced by a passivating zinc plating, a ground coating, an anti-fingerprint treatment, or an activation process such as a corona or a flame treatment.

The sub-frames 7a, 7b are attached to the insulation panel
20 2 in the manufacturing phase of the element 1. The glue may be e.g. polyurethane (PUR) or silyl modified polymer (SMP). An advantage of the SMP is that in the gluing process there is not released any potentially harmful emissions.

25 According to an aspect, there is layer of at least 20 mm, preferably at least 70 mm, of insulation panel between the outer surface 8 and the attaching arm 10. An advantage is that the good insulation properties of the
30 wall/ceiling/floor may be ensured.

The building system 100 shown in Figure 1 further comprises a connecting element 4 that is at least essentially as long as the sub-frame 7a, 7b. In another embodiment, the
35 connecting element 4 is essentially shorter than the sub-frame 7a, 7b, e.g. 80 % of the length of the sub-frame.

When connecting two elements 1, the connecting element 4 is arranged on sub-frames 7a, 7b of two adjacent elements 1. The connecting element 4 keeps together said sub-frames 7a, 7b of adjacent elements 1.

In an embodiment, the metal frame 3 comprises at least one auxiliary profile 25 is attached to the prefabricated element 1 between two sub-frames 7a, 7b. The auxiliary profile 25 may bear load and give support for cladding or facing panels attached to the building system 100. The auxiliary profile may be attached to the element 1 in manufacturing of the element 1, or in a construction site of the building.

15

Figures 2a - 2h are schematic top views of embodiments of sub-frames of the arrangement.

The cross-section (transverse to the length of thereof) of the sub-frame 7a, 7b comprises an attaching arm 10 extending along the corresponding edge surface 6a, 6b, and an intruding section 11 that is arranged in the attaching arm 10 in an angle, preferably in right angle, respect to the attaching arm 10. The intruding section 11 intrudes into the insulation element 2, thus attaching the sub-frame to the insulation element.

The cross-section of the sub-frame 7a, 7b further comprises a box-type structure 12 arranged distally from the intruding section 11. In an embodiment, the length of the box-type structure 12 is somewhat shorter than the length of the sub-frame 7a, 7b. This is especially the case in those embodiments where the box-type structures 12 are arranged to carry a transversal upper frame member 28, shown in Figure 1, the upper surface of which is to be adapted to the same level with the upper end of the sub-frames.

8

The box-type structures 12 carry largely vertical loads exerting to the building system 100.

In an embodiment, the essentially whole of the length of the sub frame 7a, 7b have a cross-section comprising the attaching arm 10, the intruding section 11, and the box-type structure 12. In another embodiment, some section(s) of length of the sub frame 7a, 7b is/are exclusive of at least one of the attaching arm 10 and the intruding section 11.

The box-type structure 12 comprises walls 13 and corners 14 constituting a closed or partly open construction. The box-like structure 12 extends from the attaching arm 10 and is arranged on the outer surface 8 or on the inner surface 9 of the insulation panel 2.

In an embodiment, the cross-section of the box-type structure 12 is an open structure. Some embodiments are shown in Figures 2a and 2b. An advantage is that the structure is easy and simple to manufacture.

In another embodiment, the cross-section of the box-type structure 12 is a closed structure. Some embodiments are shown in Figures 2c - 2h. An advantage is that the structure may carry high loads.

In an embodiment of the closed structure, the box-type structure 12 is closed by a glue layer 22, a welded joint 23 and/or a fixing element 24. The fixing element 24 may be e.g. a screw, a rivet, etc.

In an embodiment, the box-type structure 12 comprises at least three corners 14 when seeing from the end thereof. In an embodiment, the box-type structure 12 comprises at least four corners 14 when seeing from the end thereof. In

an embodiment, the box-type structure 12 comprises at least five corners 14 when seeing from the end thereof. An advantage is that the more corners, the higher is the stiffness of the structure.

5

In an embodiment, the attaching arm 10 is straight when seeing from the end thereof. In another embodiment, the attaching arm 10 comprises at least one bend 5 when seeing from the end thereof, and the edge surface 6a, 6b of the insulation panel respective shapes adapted to the shape of the attaching arm 10, and the bend 5 may comprise e.g. at least three corners. In another embodiment, the attaching arm 10 comprises corrugations. Advantages of these embodiments are that the stiffness is increased and more surface for gluing created.

10
15

The corners 14 and bends 5 stiffens the structure of the building system 100. Additionally, they may form tongue-and-groove-type attaching means in connections of two elements 1.

20

In an embodiment, the intruding section 11 is arranged at the distal end of the attaching arm 10. An advantage is that as the distance to the box-type structure 12 is maximized, and the stiffness of the element 1 may be optimized.

25

In an embodiment, the intruding section 11 is arranged in angle (A) of 90° in the attaching arm 10. An advantage is that the intruding section 11 is simple to push in the material of the insulation panel, and also strength of the element may be increased.

30

In an embodiment, the intruding section 11 comprises corrugations. An advantage is that the stiffness is increased and more surface for gluing created.

35

Figures 3a - 3g are schematic top views of embodiments of connecting elements of the arrangement.

5 The connecting element 4 is at least essentially as long as the sub-frame 7a, 7b. In an embodiment, the length of the connecting element 4 is at least 80 % of the length of the sub-frame 7a, 7b. The connecting element 4 has a cross-section comprising two arms 15a, 15b and a connect-
10 ing section 16 connecting said two arms, the cross-section having basically a shape of a U-profile. The connecting element 4 keeps together said sub-frames 7a, 7b of adjacent elements 1.

15 The width of the connecting element 4 is dimensioned such that it may be attached on two adjacent sub-frames 7a, 7b. In an embodiment, said width is in range of 150 - 350 mm.

The depth of the connecting element 4 is dimensioned such
20 that the arms 15a, 15b admit of a proper attachment of the sub-frames 7a, 7b. In an embodiment, the depth is in range of 30 - 150 mm.

According to an aspect of the invention, the connecting
25 element 4 consists of one connecting-component 17, shown in Figure 1, the length of which is at least essentially equal to the height of sub-frame 7a, 7b. An advantage is that a very sturdy combination of the sub-frames and the connecting element may be achieved.

30 According to another aspect of the invention, the connecting element 4 consists of plurality of connecting-components 17 that, in use, are arranged successively on the sub-frames 7a, 7b of the two adjacent elements 1. An
35 advantage is that handling of the shorter connecting-components may be easier.

In an embodiment, there are one or more second connecting elements 20 that, in use, are arranged on the connecting element(s) 4, thus creating a multi-layered structure of connecting elements. An advantage is that the structure may be tailored easily to the requirements of the building.

In an embodiment, the sub-frame 7a, 7b and the connecting element 4, and the second connecting elements 20, if any, comprise openings 21, shown in Figure 1, that constitute, in use, a cross-wise passage there through. An advantage is that any cables, pipes, ducts for functions needed in the building may be arranged easily in the building system.

In an embodiment, the connecting element 4 comprises a sloping 26 arranged at the free end of at least one of the arm 15a, 15b. An advantage is that the mounting of the connecting element may be facilitated.

According to an aspect, the connecting element 4 creates with the sub-frames 7a, 7b a sandwich structure that prevents efficiently twisting and buckling typical for metallic profiles.

Figure 4 is a schematic top view of an assembly method step of the arrangement.

In the method for constructing a building, there are connected plurality of prefabricated elements 1 described in this description and created thus a demanded wall, floor, roof or ceiling of the building.

According to an aspect, when building a wall, the building system 100 comprises a transversal bottom element 27 shown

in Figure 1, on which the prefabricated elements 1 are erected. In an embodiment, the bottom element is a steel L-profile. The bottom element is preferably dimensioned such that it does not extend to the plane of the outer surface 8 of the insulation panel 2. Thus, the insulation properties of the element 1 may be maintained.

The building system 100 may also comprise a transversal upper frame member 28 arranged on top of the box-type structure 12, and in some cases, also on the attaching arm 10 and the intruding section 11. The upper frame member 28 may be e.g. steel L-profile, and dimensioned according to the same principles as described above in connection with the bottom element.

In the method two prefabricated elements 1 are connected by contacting their opposite edge surfaces 6a, 6b to each other. Then, the sub-frames 7a, 7b of said prefabricated elements 1 are attaching to each other. In an embodiment, the sub-frames 7a, 7b are attached to each other by a glue layer 22. An advantage is that the structure is even more stiff and strong.

Glue used in the glue layer 22 may be e.g. silyl modified polymer (SMP).

The glue layer 22 may also be arranged in a flap element, such as a tape, on one or both surfaces thereof. The flap element may have a soft and/or elastic base layer. In an embodiment, the flap element covers all the contacting surfaces between the sub-frames 7a, 7b. The contacting surfaces between the elements 1 not having the flap element may be provided with a foam layer that is fed from outer surface 8 side of the system.

35

The glue layer 22 may be arranged on all contacting surfaces where the sub-frames 7a, 7b meet each other. In another embodiment, there are selected sub-areas that are covered by the glue layer 22. Also fixing elements 24, 5 such as screws, may be used alone or together with glue for attaching the sub-frames 7a, 7b to each other.

Following connection of the sub-frames 7a, 7b, or following their attaching, the connecting element 4 is arranged 10 on said sub-frames 7a, 7b, and attached thereto.

In an embodiment, the connecting element 4 is attached to the sub-frames 7a, 7b by a glue layer. Also here the glue may comprise e.g. silyl modified polymer (SMP). Also fixing 15 elements, such as screws, may be used here, alone or together with glue.

The stiff insulation panels 2 support and prevent deformations of the sub-frames 7a, 7b, and thus the prefabricated 20 elements 1 stands well even excess loads

In an embodiment, the cross-section of the box-type structure 12 comprises a first projecting section 18 that extends sideways in direction of the surface 9, 10 of the 25 insulation panel and arranged at a distance from said surfaces. Furthermore, the first projecting section 18 is arranged on surface of the box-type structure 12 facing away from the edge surface 6a, 6b wherefrom the attaching arm 10 is extending. Similarly, the connecting element 4 30 comprises second projecting sections 19 that are arranged to fit in the shape first projecting sections 18 of sub-frames 7a, 7b. Co-operation of the first and second projecting sections 18, 19 creates a shape-based locking system between said two sub-frames 7a, 7b and the connecting 35 element 4. An advantage is that the correctness of the

fitting between the sub-frames and the connecting element may be easily detected.

5 The invention is not limited solely to the embodiments described above, but instead many variations are possible within the scope of the inventive concept defined by the claims below. Within the scope of the inventive concept the attributes of different embodiments and applications can be used in conjunction with or replace the attributes
10 of another embodiment or application.

The drawings and the related description are only intended to illustrate the idea of the invention. The invention may vary in detail within the scope of the inventive idea de-
15 fined in the following claims.

REFERENCE SYMBOLS

	1	prefabricated element
	2	insulation panel
5	3	metal frame
	4	connecting element
	5	bend
	6a, b	edge surface
	7a, b	sub-frame
10	8	outer surface
	9	inner surface
	10	attaching arm
	11	intruding section
	12	box-type structure
15	13	wall
	14	corner
	15a, b	arm of connecting element
	16	connecting section
	17	connecting-component
20	18	first projecting section
	19	second projecting section
	20	second connecting element
	21	opening
	22	glue layer
25	23	welded joint
	24	fixing element
	25	auxiliary profile
	26	sloping
	27	bottom element
30	28	upper frame member
	100	building system
	A	angle between attaching arm and intruding section

CLAIMS

1. A building system for constructing a building, the system (100) comprising:

- plurality of prefabricated elements (1), the element (1) comprising:

5

-- a self-supporting insulation panel (2) comprising a rigid insulation material and having two straight and parallel edge surfaces (6a, 6b), and an outer and inner surfaces (8, 9),

10

-- a metal frame (3), comprising a pair of sub-frames, a first sub-frame (7a) attached to a first edge surface (6a) and a second sub-frame (7b) attached to a second edge surface (6b) of the insulation panel (2),

15

-- the sub-frame (7a, 7b) extending along the length of the insulation panel,

- the length of the sub-frame (7a, 7b) having a cross-section comprising

20

--- an attaching arm (10) extending along the corresponding edge surface (6a, 6b), and

--- an intruding section (11) arranged in the attaching arm (10) and in an angle respect to that, the intruding section (11) intruding into the insulation element (5), and

25

--- a box-type structure (12) arranged distally from the intruding section (11) and comprising walls (13) and corners (14) constituting a closed or partly open construction,

30

--- the box-like structure (12) extending from the attaching arm (10) and being arranged on the outer surface (8) or on the inner surface (9) of the insulation panel (2),

the building system further comprising

- a connecting element (4), being at least essentially as long as the sub-frame (7a, 7b) and having a cross-section

35

comprising two arms (15a, 15b) and a connecting section (16) connecting said two arms, the cross-section having

basically a shape of an U-profile, the connecting element (4), in use, being arranged on sub-frames (7a, 7b) of two adjacent elements (1), said arms (15a, 15b) being situated on opposite side of the two sub-frames (7a, 7b) and keep-
5 ing together said sub-frames (7a, 7b) of adjacent elements (1).

2. The building system as claimed in claim 1, wherein the prefabricated element (1) is a wall element.
10

3. The building system as claimed in claim 1, wherein the prefabricated element (1) is a floor element.

4. The building system as claimed in claim 1, wherein the prefabricated element (1) is a ceiling element or a roof element.
15

5. The arrangement as claimed in any of the preceding claims, wherein the insulation panel (2) is a thermal insulating board.
20

6. The arrangement as claimed in any of the preceding claims, wherein material of the insulation panel (2) comprises at least one of the following foamed materials:
25 polyisocyanurate (PIR), polyurethane (PUR) and extruded polystyrene (XPS).

7. The arrangement as claimed in any of the preceding claims, wherein the insulation panel (2) has a shape of rectangle.
30

8. The arrangement as claimed in any of the preceding claims, wherein the material of the sub-frame (7a, 7b) comprises steel.
35

9. The arrangement as claimed in any of the preceding claims, wherein the connecting element (4) consists of one connecting-component (17) the length of which is at least essentially equal to the length of the insulation panel.

5

10. The arrangement as claimed in any of the preceding claims, wherein the essentially whole of the length of the sub frame (7a, 7b) have a cross-section comprising the attaching arm (10), the intruding section (11), and the box-type structure (12).

10

11. The arrangement as claimed in any of claims 1 - 9, wherein some sections of length of the sub frame (7a, 7b) is exclusive of at least one of the attaching arm (10) and the intruding section (11).

15

12. The arrangement as claimed in any of the preceding claims, wherein the attaching arm (10) is straight when seeing from the end thereof.

20

13. The arrangement as claimed in any of claims 1 - 11, wherein the attaching arm (10) comprises at least one bend (5) when seeing from the end thereof, and the edge surface (6a, 6b) of the insulation panel respective shapes adapted to the shape of the attaching arm (10).

25

14. The building system as claimed in claim 13, wherein the bend (5) comprises at least three corners.

30

15. The arrangement as claimed in any of the preceding claims, wherein the attaching arm (10) comprises corrugations.

35

16. The arrangement as claimed in any of the preceding claims, wherein the intruding section (11) is arranged at the distal end of the attaching arm (10).

17. The arrangement as claimed in any of the preceding claims, wherein the intruding section (11) is arranged in angle (A) of 90° in the attaching arm (10).

5

18. The arrangement as claimed in any of the preceding claims, wherein the intruding section (11) comprises corrugations.

10 19. The arrangement as claimed in any of the preceding claims, wherein the cross-section of the box-type structure (12) is a closed structure.

15 20. The arrangement as claimed in any of claims 1 - 18, wherein the cross-section of the box-type structure (12) is an open structure.

20 21. The arrangement as claimed in any of the preceding claims, wherein the box-type structure (12) comprises at least three corners (14) when seeing from the end thereof.

22. The arrangement as claimed in any of the preceding claims, wherein the box-type structure (12) comprises at least four corners (14) when seeing from the end thereof.

25

23. The arrangement as claimed in any of the preceding claims, wherein the box-type structure (12) comprises at least five corners (14) when seeing from the end thereof.

30 24. The arrangement as claimed in any of the preceding claims, wherein the connecting element (4) consists of one connecting-component (17) the length of which is at least essentially equal to the height of sub-frame (7a, 7b).

35 25. The arrangement as claimed in any of claims 1 - 23, wherein the connecting element (4) consists of plurality

of connecting-components (17) that, in use, are arranged successively on the sub-frames (7a, 7b) of the two adjacent elements (1).

5 26. The arrangement as claimed in any of the preceding claims, wherein
the cross-section of the box-type structure (12) comprises a first projecting section (18) extending sideways in direction of the surface (9, 10) of the insulation panel and
10 arranged at a distance from said surfaces, the first projecting section (18) being directed away from the edge surface (6a, 6b) wherefrom the attaching arm (10) is extending, and
the connecting element (4) comprises second projecting
15 sections (19) that, in use, are arranged to fit in the shape first projecting sections (18) of sub-frames (7a, 7b) of the two adjacent elements (1), thus making a locking system between said two sub-frames (7a, 7b) of the two adjacent elements (1).

20

27. The arrangement as claimed in any of the preceding claims, comprising second connecting elements (20) that, in use, are arranged on the connecting element(s) (4).

25 28. The arrangement as claimed in any of the preceding claims, wherein the sub-frame (7a, 7b) and the connecting element (4) comprise openings (21) that constitute, in use, a passage through the sub-frames (7a, 7b) and the connecting element (4) attached together.

30

29. The arrangement as claimed in any of the preceding claims, wherein the sub-frame (7a, 7b) is attached to the insulation panel (2) by a glue layer (22).

35 30. The arrangement as claimed in any of the preceding claims, wherein the sub-frames (7a, 7b) of two adjacent

elements (1) are attached to each other by a glue layer (22).

31. The arrangement as claimed in any of the preceding
5 claims, wherein the sub-frames (7a, 7b) of two adjacent elements (1) are attached to the connecting element (4) by a glue layer (22).

32. The arrangement as claimed in any of claims 1 - 19 or
10 22 - 31, wherein the box-type structure (12) is closed by at least one of the following: a glue layer (22), a welded joint (23) and a fixing element (24).

33. The arrangement as claimed in claim 30 or 31, wherein
15 also fixing elements (24) are arranged to attach the sub-frames (7a, 7b) or sub-frames (7a, 7b) and the connecting element (4).

34. The arrangement as claimed in any of the preceding
20 claims, wherein, in use, at least one auxiliary profile (25) is attached to the prefabricated element (1) between two sub-frames (7a, 7b).

35. The arrangement as claimed in any of the preceding
25 claims, wherein the insulation panel (2) comprises one homogenous layer of the rigid foam insulation material.

36. A method for constructing a building, the method comprising:
30 - connecting two of prefabricated elements (1) according to any of the preceding claims by contacting their opposite edge surfaces (6a, 6b) to each other,
- attaching the sub-frames (7a, 7b) of said prefabricated elements (1) to each other,
35 - arranging the connecting element (4) according to any of the preceding claims on said sub-frames (7a, 7b), and

- attaching said connecting element (4) to said sub-frames (7a, 7b).

1/6

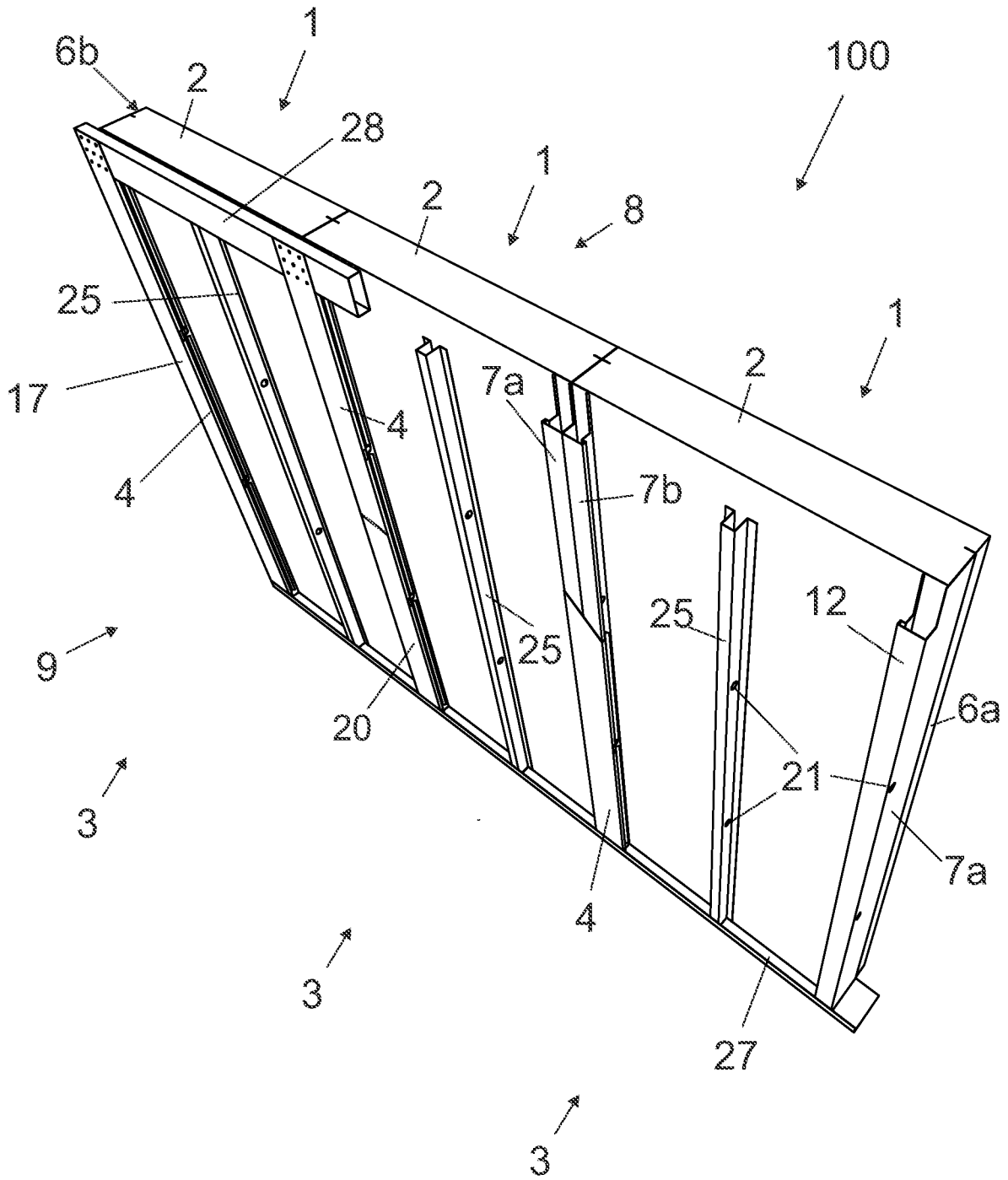
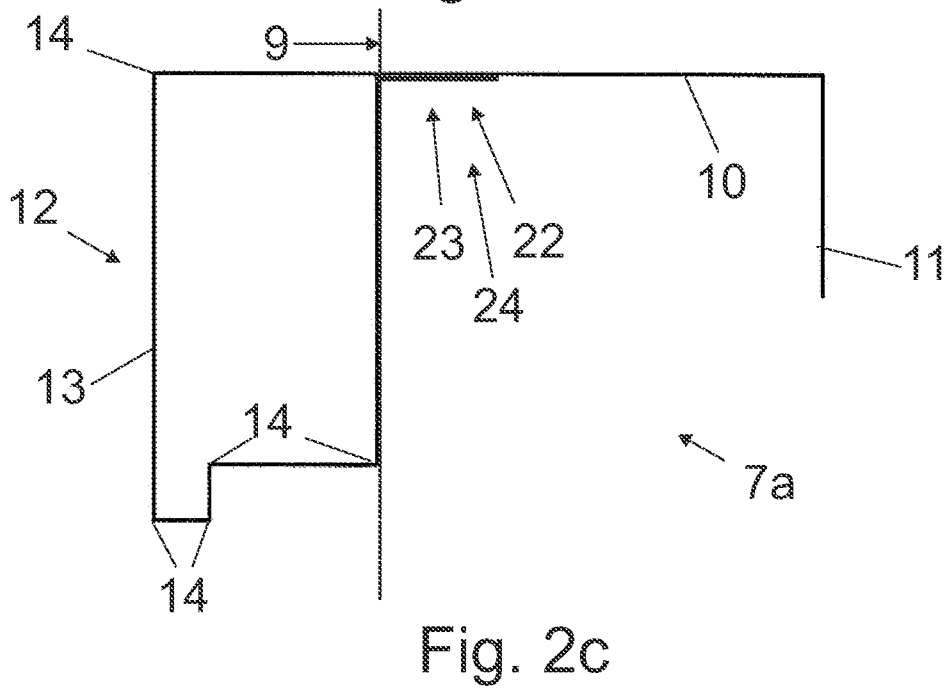
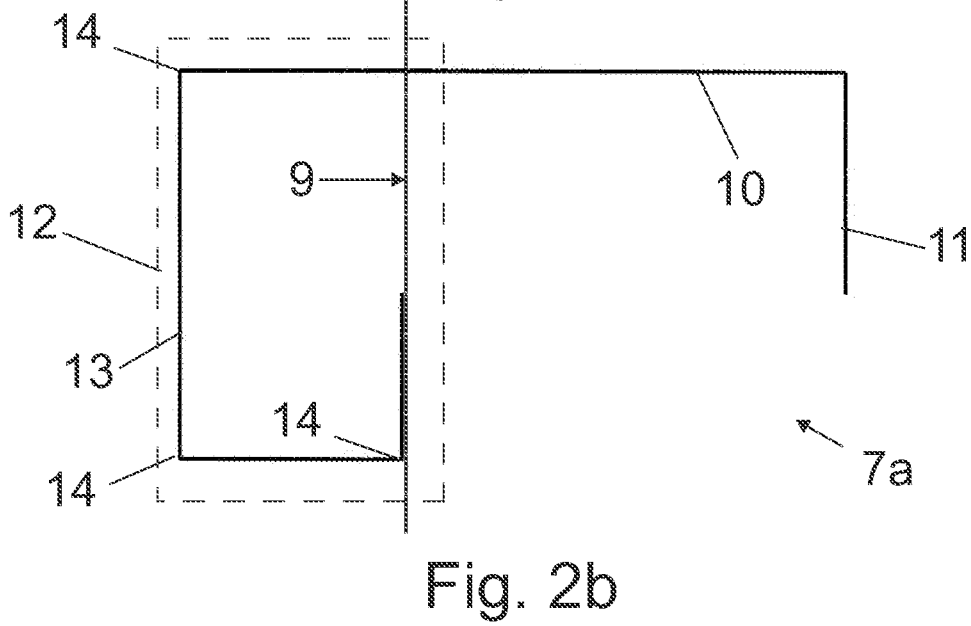
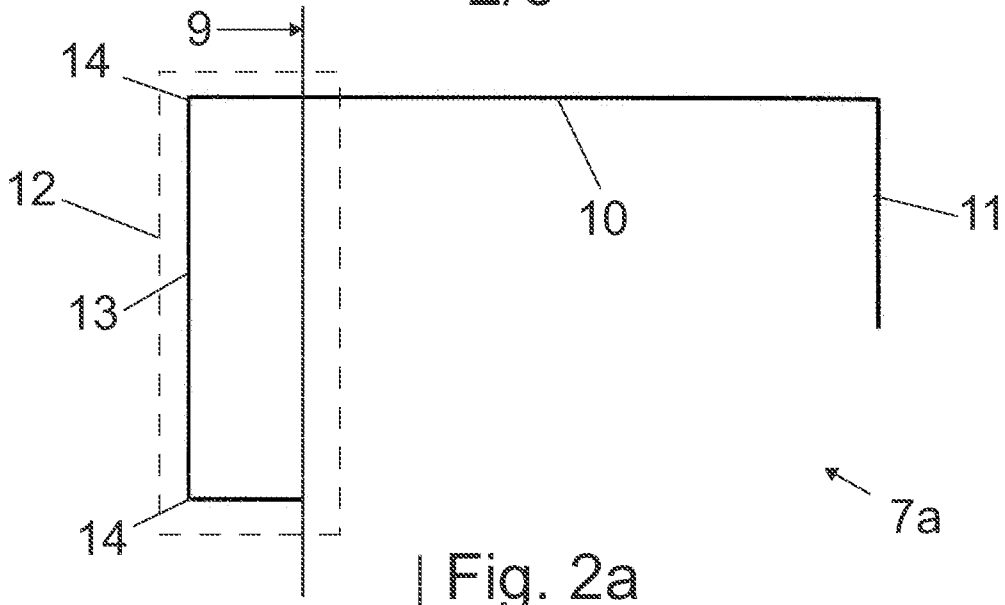
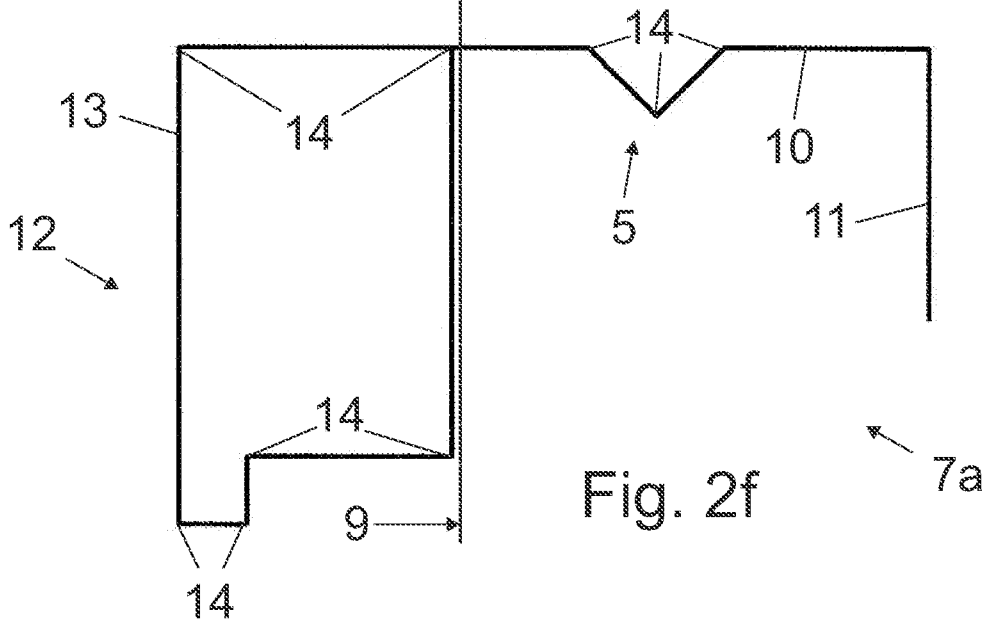
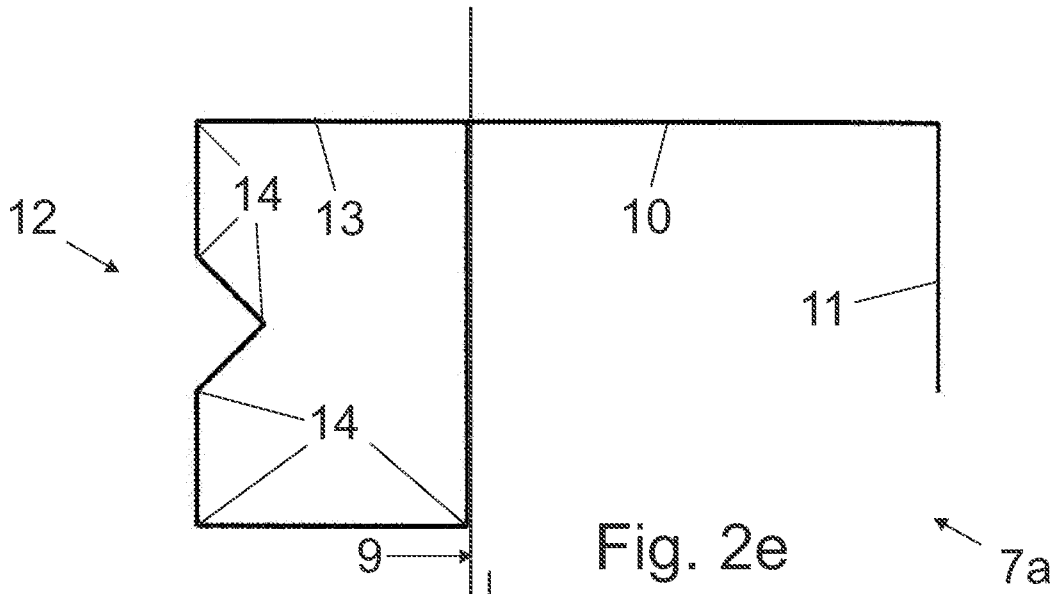
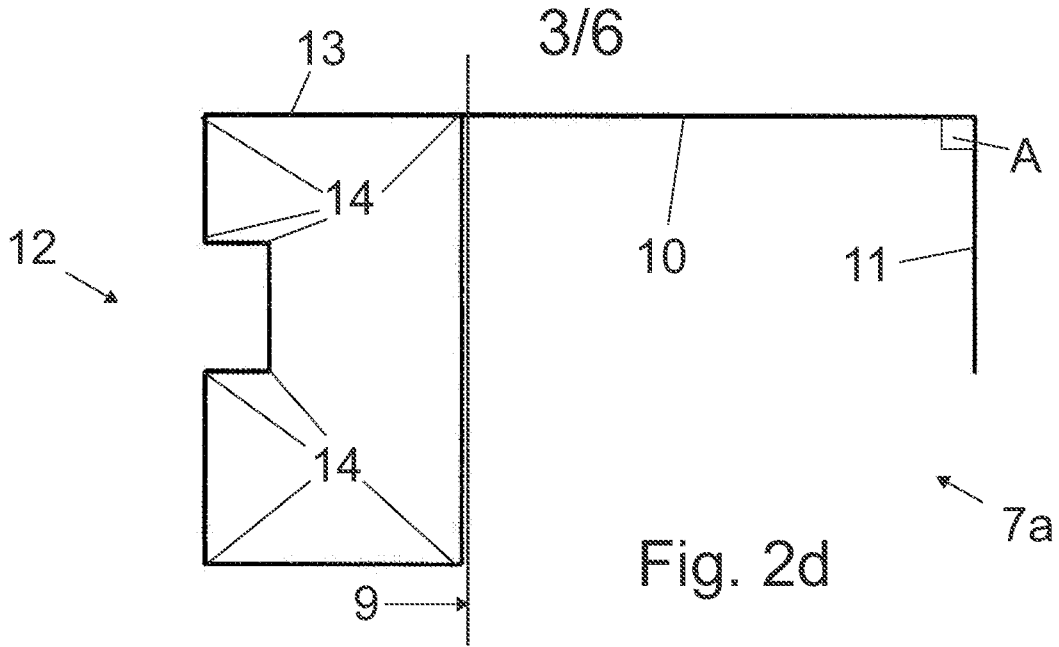
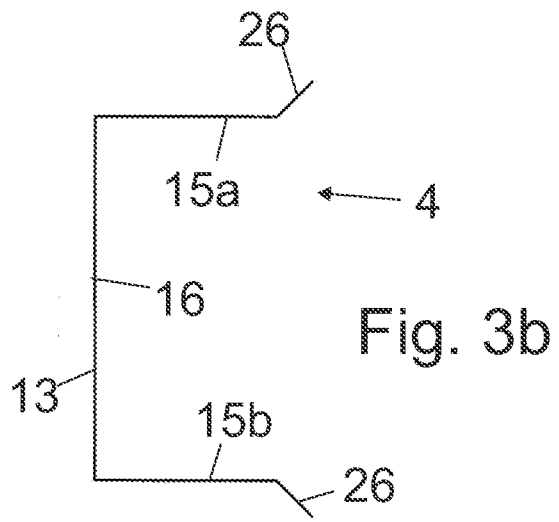
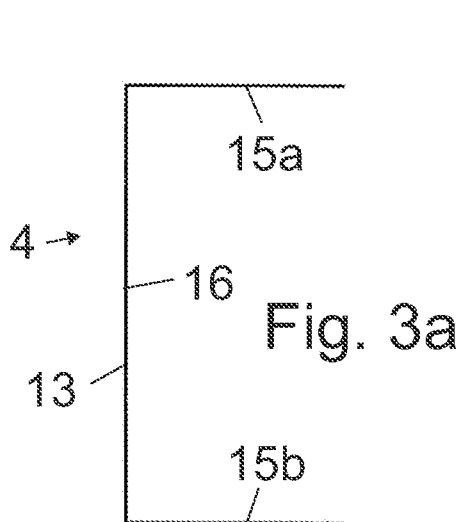
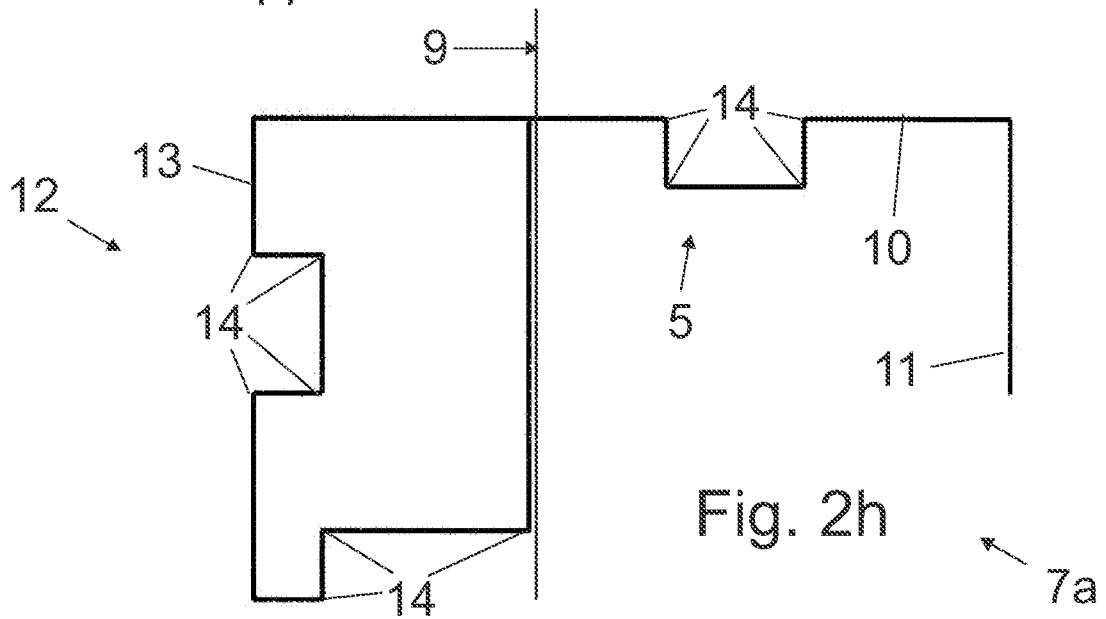
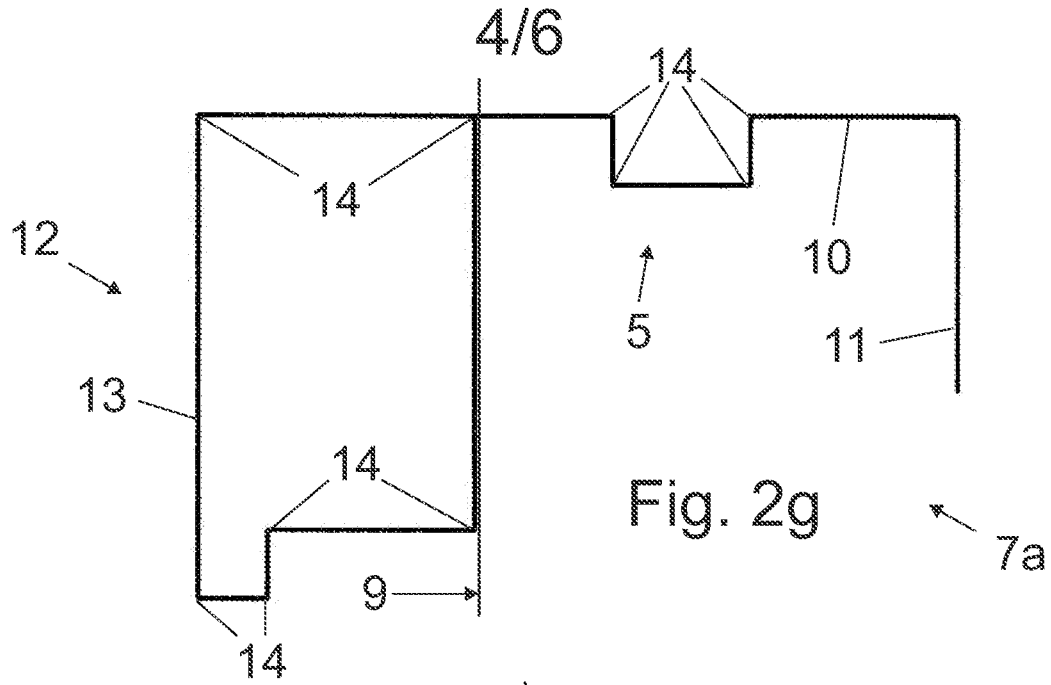

Fig. 1

2/6







5/6

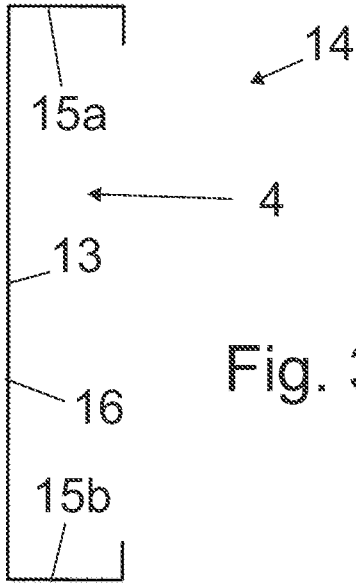

Fig. 3c

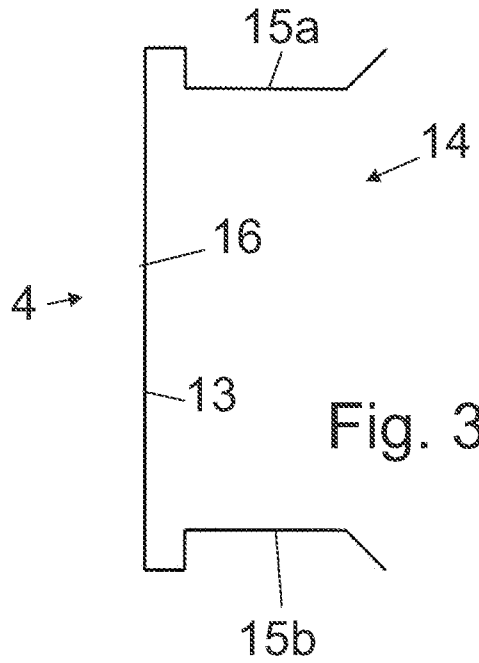

Fig. 3d

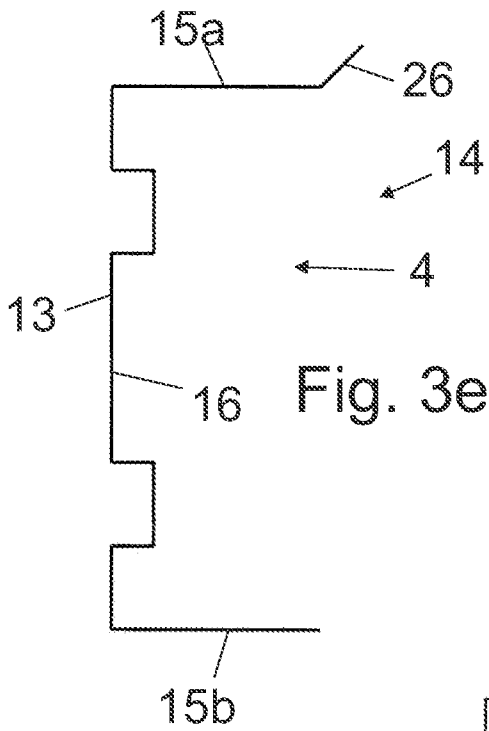

Fig. 3e

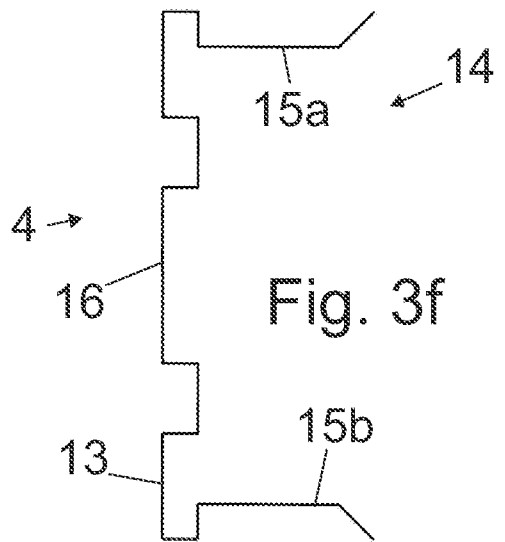

Fig. 3f

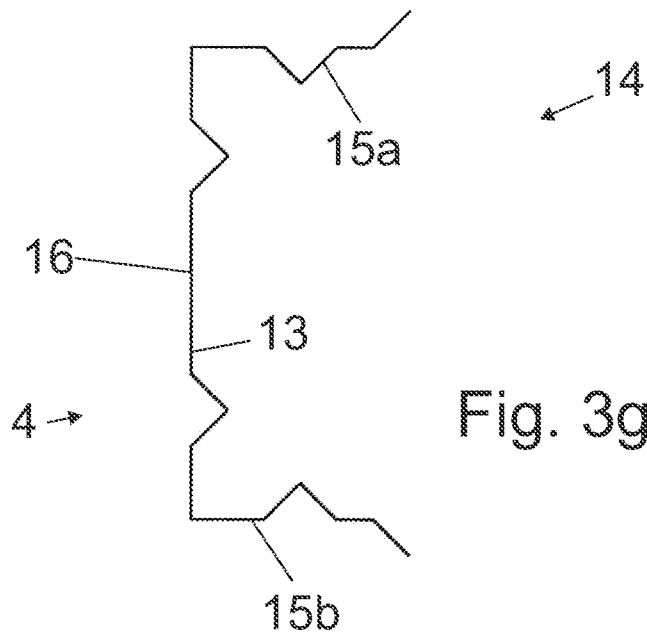

Fig. 3g

6/6

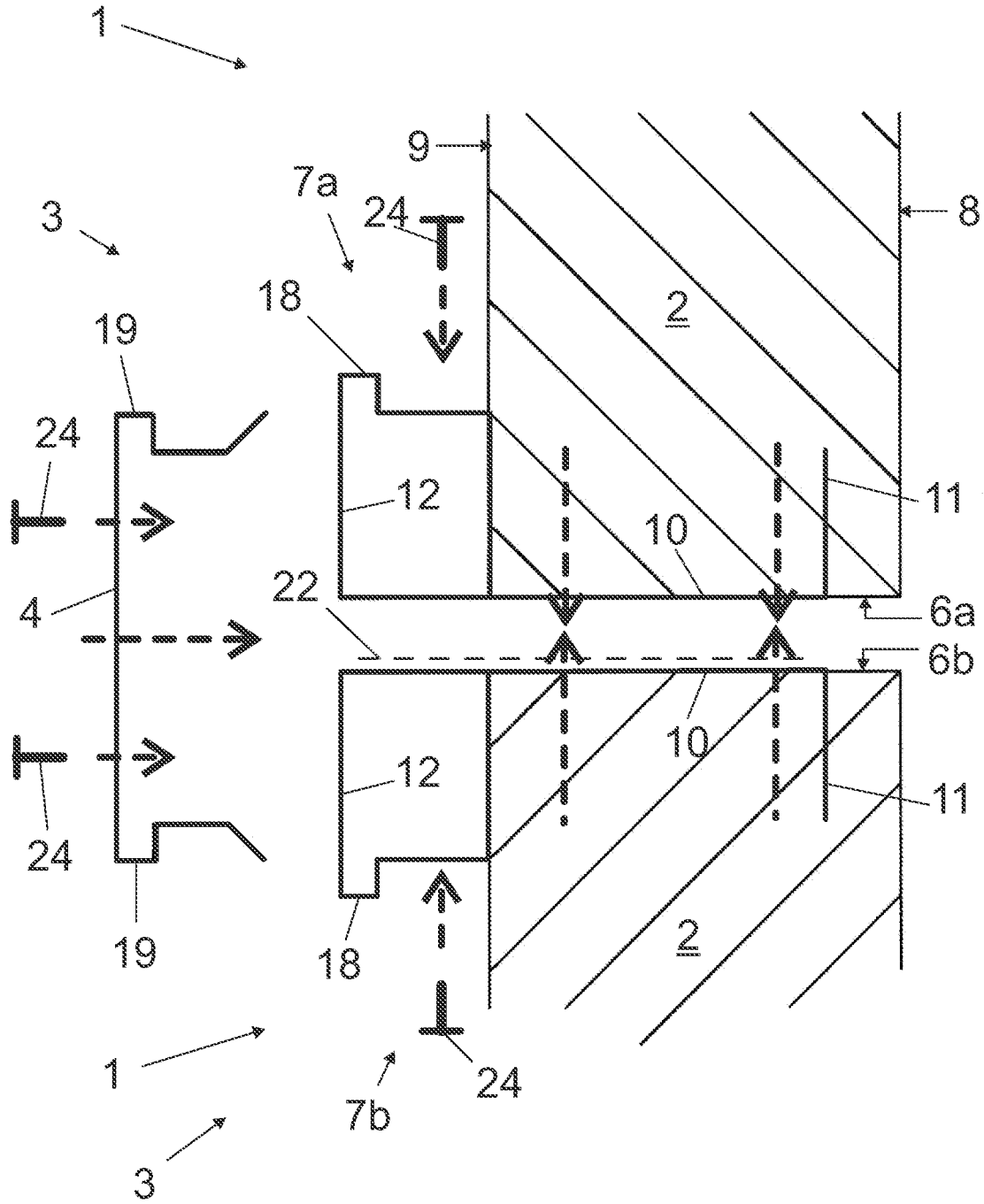

Fig. 4

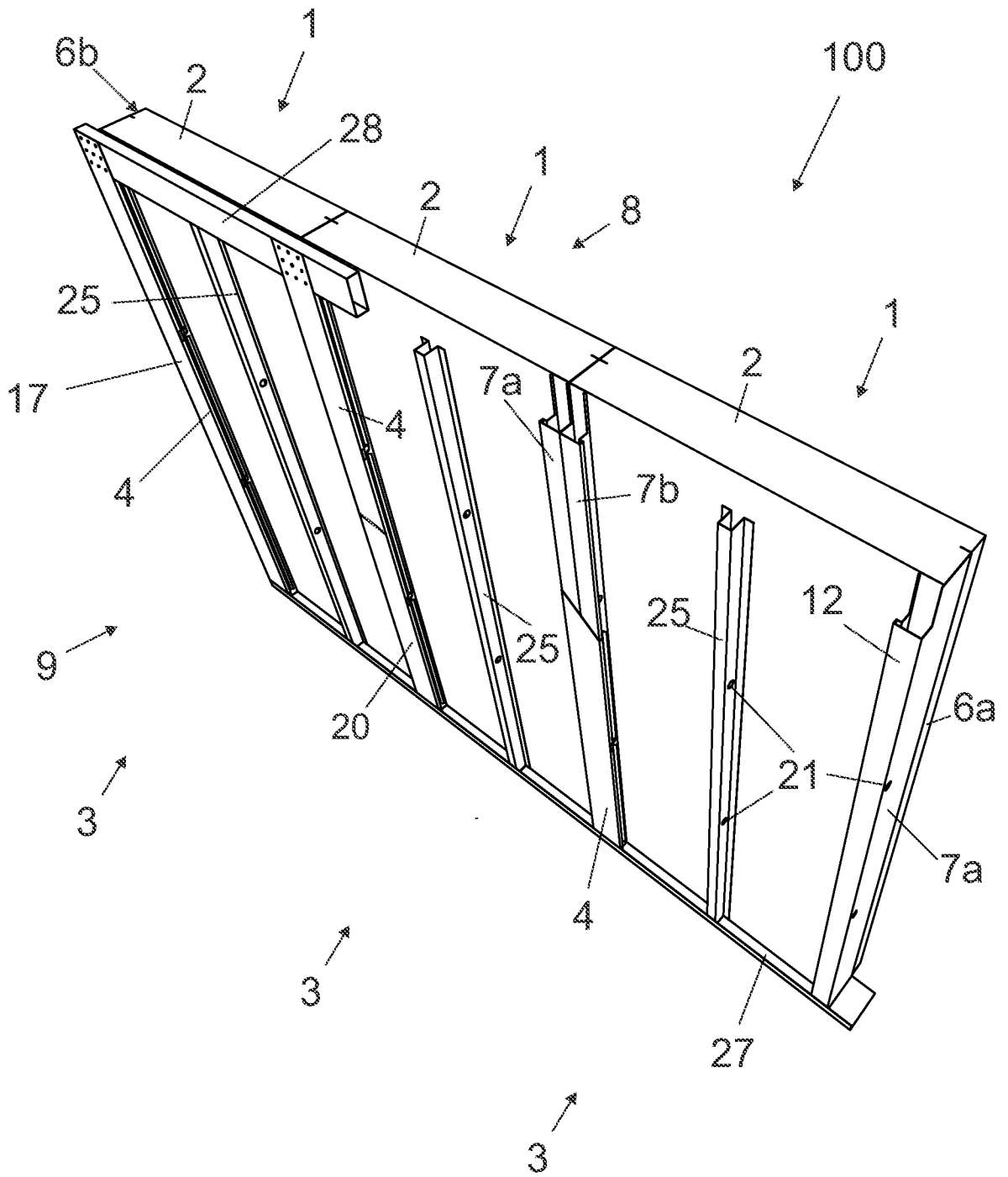

Fig. 1