

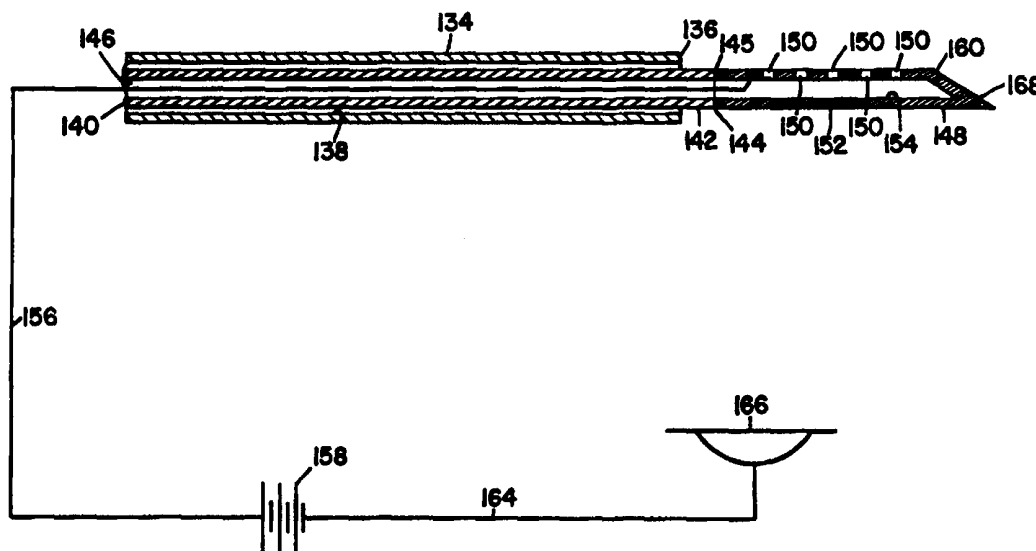

INTERNATIONAL APPLICATION PUBLISHED UNDER THE PATENT COOPERATION TREATY (PCT)

<p>(51) International Patent Classification <sup>6</sup> : A61N 1/30</p>	<p>A1</p>	<p>(11) International Publication Number: <b>WO 99/04851</b>                   (43) International Publication Date: 4 February 1999 (04.02.99)</p>
<p>(21) International Application Number: PCT/US98/15051                  (22) International Filing Date: 22 July 1998 (22.07.98)                  (30) Priority Data:                  08/898,656 22 July 1997 (22.07.97) US                  (71) Applicant: EMED CORPORATION [US/US]; 651 Campus Drive, St. Paul, MN 55112 (US).                  (72) Inventors: SHAPLAND, J., Edward; 4322 Rustic Place, Shoreview, MN 55126 (US). WALSH, Robert, G.; 17185 Jackson Trail, Lakeville, MN 55044 (US). VANDEN HOEK, John, C.; 11473 - 199th Avenue, Elk River, MN 55330 (US).                  (74) Agent: BRUESS, Steven, C.; Merchant, Gould, Smith, Edell, Welter &amp; Schmidt, P.A., 3100 Norwest Center, 90 South Seventh Street, Minneapolis, MN 55402-4131 (US).</p>	<p>(81) Designated States: AL, AM, AT, AT (Utility model), AU, AZ, BA, BB, BG, BR, BY, CA, CH, CN, CU, CZ, CZ (Utility model), DE, DE (Utility model), DK, DK (Utility model), EE, EE (Utility model), ES, FI, FI (Utility model), GB, GE, GH, GM, HR, HU, ID, IL, IS, JP, KE, KG, KP, KR, KZ, LC, LK, LR, LS, LT, LU, LV, MD, MG, MK, MN, MW, MX, NO, NZ, PL, PT, RO, RU, SD, SE, SG, SI, SK, SK (Utility model), SL, TJ, TM, TR, TT, UA, UG, UZ, VN, YU, ZW, ARIPO patent (GH, GM, KE, LS, MW, SD, SZ, UG, ZW), Eurasian patent (AM, AZ, BY, KG, KZ, MD, RU, TJ, TM), European patent (AT, BE, CH, CY, DE, DK, ES, FI, FR, GB, GR, IE, IT, LU, MC, NL, PT, SE), OAPI patent (BF, BJ, CF, CG, CI, CM, GA, GN, GW, ML, MR, NE, SN, TD, TG).</p> <p><b>Published</b>  <i>With international search report.</i></p>	

(54) Title: IONTOPHORETIC DELIVERY OF AN AGENT INTO CARDIAC TISSUE



(57) Abstract

An apparatus for delivering an agent directly into a cardiac muscle. The apparatus comprises an elongated member. The elongated member defines a deployment lumen and a distal tip. A hollow needle is configured to be inserted into the cardiac muscle. The needle is operably connected to the elongated member. The needle has a side portion and defines an outlet port in the side portion. First and second electrodes are configured to be electrically connected to a power supply. The first electrode is positioned to be in direct electrical communication with agent flowing through the outlet port.

**FOR THE PURPOSES OF INFORMATION ONLY**

Codes used to identify States party to the PCT on the front pages of pamphlets publishing international applications under the PCT.

AL	Albania	ES	Spain	LS	Lesotho	SI	Slovenia
AM	Armenia	FI	Finland	LT	Lithuania	SK	Slovakia
AT	Austria	FR	France	LU	Luxembourg	SN	Senegal
AU	Australia	GA	Gabon	LV	Latvia	SZ	Swaziland
AZ	Azerbaijan	GB	United Kingdom	MC	Monaco	TD	Chad
BA	Bosnia and Herzegovina	GE	Georgia	MD	Republic of Moldova	TG	Togo
BB	Barbados	GH	Ghana	MG	Madagascar	TJ	Tajikistan
BE	Belgium	GN	Guinea	MK	The former Yugoslav Republic of Macedonia	TM	Turkmenistan
BF	Burkina Faso	GR	Greece			TR	Turkey
BG	Bulgaria	HU	Hungary	ML	Mali	TT	Trinidad and Tobago
BJ	Benin	IE	Ireland	MN	Mongolia	UA	Ukraine
BR	Brazil	IL	Israel	MR	Mauritania	UG	Uganda
BY	Belarus	IS	Iceland	MW	Malawi	US	United States of America
CA	Canada	IT	Italy	MX	Mexico	UZ	Uzbekistan
CF	Central African Republic	JP	Japan	NE	Niger	VN	Viet Nam
CG	Congo	KE	Kenya	NL	Netherlands	YU	Yugoslavia
CH	Switzerland	KG	Kyrgyzstan	NO	Norway	ZW	Zimbabwe
CI	Côte d'Ivoire	KP	Democratic People's Republic of Korea	NZ	New Zealand		
CM	Cameroon			PL	Poland		
CN	China	KR	Republic of Korea	PT	Portugal		
CU	Cuba	KZ	Kazakstan	RO	Romania		
CZ	Czech Republic	LC	Saint Lucia	RU	Russian Federation		
DE	Germany	LI	Liechtenstein	SD	Sudan		
DK	Denmark	LK	Sri Lanka	SE	Sweden		
EE	Estonia	LR	Liberia	SG	Singapore		

IONTOPHORETIC DELIVERY OF AN AGENT  
INTO CARDIAC TISSUE

Co-pending Applications

5           The present application is being filed concurrently with an application entitled NEEDLE FOR IONTOPHORETIC DELIVERY OF AN AGENT and identified with attorney docket number 9367.47US01, the disclosure of which is hereby incorporated by reference.

Technical Field

10           The present invention relates to delivery of an agent to a patient's heart, and more particularly, to iontophoretic delivery of an agent directly into cardiac tissue.

Background

15           The human heart is an amazing organ. It is a self regulating pump that cooperates with the respiratory and nervous system to oxygenate and distribute blood throughout the body. This mechanism sustains life.

          Referring to Figure 1, the heart 100 is a muscle that defines atria and ventricles. The atria include a left atrium 102 and a right atrium 104. The ventricles  
20 include a left ventricle 106 and a right ventricle 108. The atrial myocardium 110 forms the outer wall of the atria. The ventricular myocardium 112 forms the outer wall of the ventricles. The interventricular septum 114 divides the left and right ventricles 106 and 108.

          The heart 100 contracts and relaxes in an orderly sequence during  
25 each heart beat in order compress these chambers 102, 104, 106, and 108 and pump blood through the systemic circulatory system. The systemic circulatory system includes blood vessels that carry the blood to all areas of the body, including the muscles that forms the heart 100 itself.

          The heart beat originates in a cardiac conduction system 116 that  
30 distributes cardiac impulses, which is an electrical signal, throughout the heart 100. These electrical impulses stimulate the heart 100 and cause it to contract and pump blood. The cardiac conduction system 116 is formed from cells and striated muscle fibers. Although the muscle fibers are striated, the conduction system 116 does not have defined or distinct boundaries.

35           The cardiac impulses originate in a sinoatrial node (SA node) 118 that functions as a type of natural pacemaker. The signal then radiates throughout the atrial myocardium 110 via atrial pathways 120. The cardiac impulses in the

atrial pathways 120 stimulate the atrial myocardium 110 and causes the atria 102 and 104 to contract and blood to flow into the ventricles 106 and 108.

The atrial pathways 120 also carry the electrical impulses to another node, called the atrioventricular node (AV node) 122. From the AV node 122, the cardiac impulses are transmitted along a group of fibers called the bundle of His 124, which runs along the ventricular septum 114. The bundle of His 124 splits into a right bundle branch 126 and a left bundle branch 128. In a normal heart, the bundle of His 124 provides the only path for cardiac impulses between the atrial myocardium 110 and the ventricle myocardium 112.

The cardiac impulses pass from the left and right branches 126 and 128 to the Purkinje system 130, which provide pathways throughout the ventricular myocardium 112. The cardiac impulses in the Purkinje system 130 cause the ventricular myocardium 112 to contract and pump blood from the left and right ventricular chambers 106 and 108 into the systemic circulatory system. There is a slight delay between contraction of the atrial myocardium 110 and the ventricular myocardium 112.

In this system, the SA node 118 is a cardiac pacemaker that times the rhythm of the heart 100. The AV node 122 introduces a delay in the cardiac impulses received from the SA node 118 and coordinates contraction of the atria and the ventricles 102, 104, 106, and 108. As shown in figure 2, these pathways can become defective after an injury such as myocardial infarction, which is an area of tissue in the wall of the heart that is damaged due to an interruption of the blood supply. Arteriosclerosis is a common cause of myocardial infarction. As a result, a reentry circuit 132 is formed that provides a path of the cardiac impulses to circle around and move in the wrong direction. These reentry circuits typically cause a form of tachycardia, which is a fast and unnatural heart beat.

Some reentry circuits are microscopic, covering only a few millimeters distance, and are isolated in either the atria 102 and 104 or the ventricles 106 and 108. The tachycardia caused by reentry circuits can result in fibrillation in which the heart 100 quivers in a chaotic pattern. In extreme cases the tachycardia can cause a reduced output of the heart and 100 even cause the circulation of blood to stop. This condition can lead to death if it lasts more than a few minutes. This danger is especially high if the reentry circuits are in the ventricle myocardium 112. Other reentry circuits are macroscopic and may even extend between the atrial and ventricle myocardiums 110 and 112. In this situation, the cardiac impulses are rerouted back to the atrial myocardium 110 causing it to prematurely beat. The reentry circuit also can propagate within the AV node causing a form of nodal tachycardia.

One way to treat tachycardias is to destroy tissue forming the reentry circuit. In order to destroy this tissue, a caregiver will map the electrical activity of the heart using an electrophysiological catheter or similar probe, which is placed within the heart. After the reentry circuit is located, the caregiver will kill or ablate the tissue forming the reentry circuit with a high energy electric current. Other techniques for killing this target tissue include the application of laser energy, microwave heating, and cryoablation, which is extreme cooling.

These techniques have some significant shortcomings. For example, microwave energy lacks focus and laser energy must cut through the heart muscle to reach the reentry circuit. As a result, these techniques often fail to ablate tissue deep within the heart wall and thus fail to kill all of the tissue that forms the reentry circuit. These techniques also kill healthy cardiac tissue surrounding the reentry pathway and may compromise the mechanical function of the heart. Furthermore, cryoablation and laser ablation is very expensive and requires a significant amount of training beyond that required for other forms of ablation.

Another shortcoming is that the only current technique to test if the caregiver has identified the correct tissue as the site of the reentry circuit is to actually ablate the tissue and then electrically stimulate the heart in an attempt to induce a tachycardia. If a tachycardia is induced, the caregiver must perform additional ablations. This trial and error method results in the destruction of healthy cardiac tissue.

Therefore, there is a need for an apparatus and method to destroy cardiac tissue forming reentry circuits while affecting only a minimal amount of normal tissue. There is a further need for a way to isolate and test for the presence of a reentry circuit without killing the cardiac tissue.

Coronary disease that restricts the flow of blood to the cardiac muscle is another ailment that some people experience. A lack of blood flow is commonly caused by a blockage such as arteriosclerosis. The blockage causes an infarction, which is a localized area of dead tissue cells that is surrounded by an area that has reduced blood flow. This area of reduced blood flow is called a zone of ischemia. Such blockages are usually treated with by-pass surgery or angioplasty in an effort to restore blood flow to the zone of ischemia. However, a high percentage of these procedures fail due to reclosure of the artery. Other people suffer from diffuse coronary disease, which is the blockage of many coronary arteries. By-passing or reopening all of these arteries is not an option because of the extreme procedural difficulties and trauma that it would cause. As a result, there is also a need to provide an adequate flow of blood to ischemic areas of the heart without by-pass surgery or reopening the blocked vessels.

### Summary

The present invention is directed to an apparatus for delivering an agent directly into a cardiac muscle. The apparatus comprises an elongated member. The elongated member defines a deployment lumen and a distal tip. A hollow  
5 needle is configured to be inserted into the cardiac muscle. The needle is operably connected to the elongated member. The needle has a side portion and defines an outlet port in the side portion. First and second electrodes are configured to be electrically connected to a power supply. The first electrode is positioned to be in direct electrical communication with agent flowing through the outlet port.

10 Yet another alternative embodiment of the present invention is directed to a method of delivering an agent directly into a cardiac muscle. The method comprises the steps of: introducing an elongated body into the patient, the elongated body having a needle at its distal tip; inserting the needle into the cardiac muscle, the needle being configured to deliver the agent; and iontophoretically  
15 transporting the agent into cardiac tissue proximal to the needle.

### Description of the Drawings

Figure 1 shows a human heart and illustrates the four chambers of the heart and the circuits used to conduct cardiac impulses.

20 Figure 2 shows the circuits that conduct cardiac impulses in the human heart including an abnormal reentry circuit.

Figure 3 shows a delivery device for delivering an agent into the cardiac muscle.

25 Figure 4 shows an alternative embodiment of the delivery device illustrated in Figure 3.

Figures 5-7 show alternative embodiments of a needle used with the delivery device shown in Figure 3.

Figure 8 shows another alternative embodiment of the delivery device illustrated in Figure 3.

30 Figure 9 shows another alternative embodiment of the delivery device illustrated in Figure 3.

Figure 10 shows another alternative embodiment of the delivery device illustrated in Figure 3.

35 Figure 11 shows another alternative embodiment of the delivery device illustrated in Figure 3

### Detailed Description

Various embodiments of the present invention will be described in detail with reference to the drawings, wherein like reference numerals represent like parts and assemblies throughout the several views. Reference to the various  
5 embodiments does not limit the scope of the invention, which is limited only by the scope of the claims attached hereto.

In general, the present invention relates to phoretic delivery of an agent directly into and deep within the heart muscle. Such delivery is useful for several applications including ablation of cardiac tissue and angiogenesis, which is  
10 the stimulation of new vessel growth.

The device for delivering the agent has a delivery portion such as a needle. Possible embodiments of the needle that are useful for the delivery portion include a straight hypodermic needle or a helical needle that has a corkscrew configuration. Additionally, the device includes an active driver to actively  
15 transport the agent to the abnormal cardiac tissue. An example of such an active driver includes electrodes for iontophoresis.

The present invention has many advantages. It provides precise delivery of an agent to an area sufficiently large enough to ensure treatment of the abnormal cardiac tissue while minimizing exposure of normal tissue to the agent.  
20 The present invention also provides treatment of tissue that is deep within the cardiac muscle.

If the device is used for cardiac ablation to eliminate a reentry circuit, one possible method of using the delivery device provides for delivering a reversible blocking agent to tissue that is suspected of forming the reentry circuit. While the  
25 reversible agent will temporarily block the electrical activity of the tissue, but will not kill any cardiac cells. The caregiver can then use a blocking agent to determine if the abnormal cardiac tissue that forms the reentry circuit is accurately identified. The use of a reversible blocking agent also has many advantages. For example, the caregiver can block tissue and test the heart to determine if the proper tissue was  
30 identified. These blocking agents enable the caregiver to accurately isolate the abnormal tissue without unnecessarily ablating healthy tissue or compromise the heart's mechanical function.

Another alternative procedure uses the delivery device to deliver angiogenesis agents into the cardiac muscle. The angiogenesis agents promote the  
35 growth of new blood vessels that will supply blood to an area that previously had restricted blood flow due to a blockage such as arteriosclerosis.

The present invention actively transports the agent throughout the ischemic or abnormal tissue. One possible transport mechanism that can be used is

iontophoresis. Typically, an iontophoretic device consists of two electrodes in intimate electrical contact with some portion of a patient's tissue and a reservoir containing an agent that is to be introduced into the patient's body or tissue. One electrode, called the delivery electrode, is the electrode from which the agent is delivered into the patient's body. The other electrode, called the return electrode, serves to close the electrical circuit through the body. The target area, that is the tissue to which it is desired to deliver the agent, is in the electrical path between the delivery and return electrodes.

The circuit is completed by connecting the delivery and/or return electrodes to a source of electrical energy, such as a battery or a direct current power supply. Additionally, the source of electrical energy can be controlled by a signal generator or other circuitry is electrically connected to the energy source in order to shape or otherwise control the signal used to energize the electrodes.

In iontophoresis, the agent either has a natural ionic charge or is combined with a charged carrier molecule. If the agent is positively charged, then the positive electrode (the anode) is the delivery electrode. If the agent is negatively charged, then the negative electrode (the cathode) is the delivery electrode. In this configuration, the agent is transported away from the energized delivery electrode and into the target area. Alternatively, if the agent is neither charged nor combined with a carrier molecule, delivery can rely on electroosmosis, which is a form of iontophoresis and describes the movement of water molecules that are placed within an electric field and the agent that is either suspended or in solution.

An agent can include any type of composition. Examples include drugs such as antiseptics and fixatives; compositions useful for diagnostic purposes such as dyes; genetic materials such as DNA, RNA, genes, ribozymes, antisense oligonucleotides, and other antisense materials; therapeutic agents such as cytotoxic, chemotherapeutic, antiviral agents, antibiotics, and antifungal agents; adjuvants; penetration enhancers; and other substances that have medical applications. Additionally, the term agent can mean an agent in any form. Examples of various forms of agents include solutions, solids, liquids, liposomes, dehydrated masses, and gels. Although the term is often used in a singular form, it can connote either a single agent or a combination of agents.

Referring now to Figure 3, an outer, guiding member 134 has a distal tip 136 and defines a lumen 138. The guiding member 134 is used to provide access to the heart 100. If access is through the circulatory system, the guiding member 134 is a flexible catheter that is sized to be threaded through the circulatory system and into either the left 102 and 106 or right 104 and 108 chambers of the heart 100. In various possible embodiments, the delivery system is steerable, torqueable, or



deflectable. If access to the heart 100 is through a minimally invasive puncture in the chest or open chest surgery, the guiding member 134 has more rigidity such as a cannula.

5 An inner member 140 is sized to be slidably inserted into the lumen 138 of the guiding member 134. The inner member 140 has an elongated body 142. The elongated body has a distal portion 144 and a distal end 145. The elongated body also has a proximal portion (not shown) that projects from the proximal end (not shown) of the guiding member 134. The elongated body 142 defines a delivery lumen 146. A needle 148 is operably connected to the distal end 145. Alternative configurations for the needle are described in more detail below. Again, if access to the heart 100 is through the circulatory system, the elongated body 142 is flexible. If access is through a puncture or incision in the chest, the elongated body 142 can be substantially rigid.

10 The needle 148 can be deployed from or retracted into the distal tip 136 of the guiding member 134. A gripping member (not shown) such as a handle or collar is operably connected to the proximal portion of the elongated body 142. Deployment or retraction of the needle 148 is accomplished by pushing or pulling the gripping member. The proximal portion of the elongated body 142 can have graduations so the caregiver can determine the position of the needle 148 relative to the distal tip 136 of the guiding member 134. Additionally, the gripping member can be positioned to limit the distance that the needle 148 can be deployed from the distal tip 136 of the guiding member 134.

15 The needle 148 is formed with an electrically conductive material and functions as a delivery electrode. The material can be either sacrificial or non-sacrificial. Examples of sacrificial materials include silver/silver chloride, copper, tin, nickel, iron, lithium, and amalgams thereof. Examples of non-sacrificial materials include platinum, gold, and other noble metals. The needle 148 also can be formed of zirconium; iridium; titanium; certain carbons, and stainless steel, some of which may oxidize under certain circumstances. The grade of stainless steel is one factor that determines whether stainless steel oxidizes. Another factor that determines whether there are obvious signs of oxidation in metals is the surface area of the delivery zone. A larger area will tend to have less relative oxidation than a smaller area. In one possible embodiment, the needle 148 is formed with a solid material. In another possible embodiment, the needle 148 is formed with a base material that is plated. Plating is advantageous because some of the conductive materials such as gold and platinum are relatively expensive.

20 The needle 148 defines at least one outlet port 150 and has an inner wall 152 that defines a delivery chamber 154. The delivery chamber 154 is in fluid

communication with the delivery lumen 146 of the inner member 140. The delivery chamber 154 can form an extension of or be a part of the delivery lumen 146. A first lead 156, or any other type of suitable conductor, extends through the delivery lumen 146 and into the delivery chamber 154. The first lead 156 is electrically  
5 connected between the needle 148 and a power supply 158. In this configuration, the needle 148 functions as a first electrode 160.

In an alternative configuration, as shown in figure 4, the first lead 156 is connected to a first electrode 162 that is separate from the needle 148. In this alternative embodiment, the first electrode 162 is positioned within the delivery  
10 lumen 146 and may be within the delivery chamber 154 of the needle 148. Additionally, if the first electrode 162 is positioned within the delivery lumen 146 and separate from the needle 148, the needle 148 may be formed from a nonconductive material.

Referring back to figure 3, a second electrode 166 is electrically  
15 connected to the power supply 158 via a second lead 164. The second electrode 164 is a patch-type electrode configured to be applied to the surface of the patient's skin. Other configurations of the second electrode 164 are possible. For example, the second electrode 164 could be mounted on the surface of the guiding member 134, mounted on the surface of the inner member 140, or otherwise positioned in the  
20 patient's body.

Figure 5 illustrates one possible embodiment of the needle 148 in more detail. In this embodiment, the needle 148 is straight and has a beveled end 168 that aids in inserting the needle 148 into the cardiac muscle. The beveled end 168 of the needle 148 is closed. The needle 148 has a gauge ranging from about 20  
25 to about 27. One factor affecting the gauge of the needle 148 that should be used is the method for introducing the needle 148 into the heart. If the needle 148 is introduced through the circulatory system, a finer and more flexible needle should be used. If the needle 148 is introduced through a puncture or incision in the patient's chest, a larger needle can be used.

The needle 148 has a shaft 170 and a delivery zone 172. The length  
30 of the delivery zone 172 is between about 0.25 inches and about 2 inches. The outlet ports 150 are defined along the delivery zone 172, and have a diameter of about 0.010 inch or less. The number of outlet ports 150 can range from 1 to 1000 or more. One factor affecting the number of outlet ports 150 is whether it is desirable  
35 to diffuse the agent in one direction or entirely around the circumference of the needle 148. Another factor affecting the number of outlet ports 150 is the size of the needle 148 and the size of the outlet ports 150. In one possible embodiment, the area of the outlet ports 150 is maximized, which allow quick and even distribution of

the agent. Possible manufacturing methods include laser drilling, electrical discharge machining, photolithography, and chemical etching.

5 Additionally, the outlet ports 150 are distributed around the entire circumference of the delivery zone. Distributing the delivery ports 150 in this manner is advantageous because it distributes the current density in order to minimize the risk of burning tissue adjacent to the delivery ports 150.

10 In an alternative embodiment, the delivery ports 150 are defined in only a portion of the circumference around the delivery zone 172. An advantage of this alternative embodiment is that it provides increased precision over the direction that the agent is transported into the heart tissue.

15 The proximal portion of the shaft 170 is covered with an insulating material 174 that is substantially non-conductive. The insulating material 174 can be a sheath, coating, covering, or similar structure. An advantage of insulating the shaft 170 is that the insulation prevents the burning of tissue at interface where the needle 148 enters the cardiac muscle. The insulating material 174 can be wrapped around the shaft 170. Alternatively, the material used to form the insulating material 174 can be painted onto the shaft 170 and cured, or the shaft 170 can be dipped into a reservoir of the insulating material and cured. This coating technique can be repeated in the order to achieve the desired thickness of the insulating sheath. If the elongated body 142 is formed from an electrically conductive material, the insulating material 174 extends along the elongated body 142 to prevent the electric current from becoming prematurely shunted into the patient's body before it reaches the delivery zone 172 of the needle 148.

25 The delivery zone 172 is covered with a spacer that prevents or minimizes direct contact between the outer surface 180 of the needle 148 and the tissue of the heart wall. In one possible embodiment, the spacer is a protective sheath or coating 176. The protective sheath 176 minimizes direct contact between the needle 148 and the cardiac tissue. As a result, burning of tissue that is directly adjacent to the delivery zone 172 of the needle 148 is minimized. Examples of material that can be used to form the protective sheath 176 include nylon and Teflon®. If a material such as nylon or Teflon® is used, the protective sheath 176 has the form of a mesh, or some similar configuration, that will allow agent and electrical current to flow through the protective sheath 176.

35 There are several techniques to apply the mesh. The mesh can be a cloth that is wrapped around the delivery zone 172. Examples of meshes include woven materials, knitted materials, or a perforated sheet. Alternative techniques for applying nylon and Teflon® mesh is to apply the material in a fluid form and either paint it on the needle 148 or dip the needle 148 into a reservoir. The fluid material is

then cured by an appropriate mechanism such as heating. This coating technique can be repeated in order to achieve the desired thickness of the protective sheath 176.

5 If Teflon® is used, one possible method of creating the mesh pattern is to apply a template to the delivery zone of the needle 148 and then apply the Teflon®. After the Teflon® has cured, the template is lifted off of the needle 148 thereby creating a mesh pattern. Yet another alternative manufacturing technique is to coat the needle 148 with the insulating material and then etch the insulating material with acid.

10 In addition to nylon and mesh, the protective sheath 176 should be formed with hollow fibers, which are porous to the agent. Once the hollow fibers become wetted, they will also allow the conduction of electricity. The fibers could be wound around the delivery zone or arranged in a variety of other configurations such as a mesh or a fabric. The protective sheath 176 also could be formed from a microporous membrane. Such a membrane is discussed in more detail in United States Patent 5,569,198, which is entitled MICROPOROUS MEMBRANE and issued on January 23, 1995, the disclosure of which is hereby incorporated by reference. Still other embodiments of the needle do not include a spacer. Rather, the outer surface of the needle at the delivery zone is exposed directly to tissue in the patient's body during use.

15 Referring now to Figure 6, an alternative embodiment of the needle 182 is substantially similar to the needle 148, and includes a shaft 170, an insulating material 174, a delivery zone 172, and a protective sheath 176. In place of the outlet ports 150, however, the needle 182 defines at least one slot 184 that extends the length of the delivery zone 172. The needle 182 can define multiple slots 184, depending on the size of the needle 182 and whether the caregiver desires to deliver agent around the entire circumference of the delivery zone 172.

20 Referring to Figure 7, yet another alternative embodiment of the needle 186 has a shaft 187, and insulating material 188 covering the shaft, a delivery zone 190, and a protective sheath 191. The delivery zone 190 has a helical or cork screw configuration. Like the other needle configurations, the needle 186 defines a delivery chamber (not shown) and at least one outlet port (not shown) in the delivery zone.

25 The helical needle configuration has several advantageous. For example, the helical needle 186 is screwed into the heart muscle and thus securely anchored in a delivery position. As a result, the needle 186 will not readily move while the heart 100 continues to beat. The needle 186 also has a larger delivery zone 190, which helps to distribute the iontophoretic current and thus reduces the risk of

burning cardiac tissue. The increased area of the delivery zone 190 also provides a greater treatment area. A related advantage is that the greater delivery zone 190 also enables the use of more delivery ports, which enables the agent to be delivered quicker and more efficiently.

5                   In yet another possible embodiment, the needle 148 is formed from Nitinol memory metal. The needle initially has a straight configuration, as shown in Figures 5 and 6, when deployed and inserted into the heart muscle. The needle 148 is then is then warmed to a predetermined temperature, which causes the configuration of the needle 148 to take on a different shape. In one possible  
10                   embodiment, this different shape helps to secure the needle 148 in a delivery position within the heart wall. The needle can be set to the predetermined temperature from the natural temperature of the heart muscle. Alternatively, a fluid at the predetermined temperature can be injected through the lumen and into the needle 148. An advantage of this embodiment is that a straight needle is easier to  
15                   insert into the heart muscle and will cause less trauma.

                  There are several possible techniques to release the needle from the heart muscle after treatment is complete. One techniques is to rotate the needle causing it to unscrew from the heart muscle. In another possible technique, the needle 148 is set to a second predetermined temperature, which will cause the needle  
20                   148 to either become flexible or to return to a straight configuration. The needle 148 then can be pulled from the heart muscle.

                  Referring to Figure 8, an alternative embodiment of the delivery device has an inner member 192 that is unitary and needle-like. The inner member 192 defines a delivery portion 194 and an elongated body 196 that forms an  
25                   elongated shaft. The first electrode 162 is positioned within the delivery lumen 146. This alternative embodiment, the delivery portion 194 can have a straight or helical configuration similar to needles 148, 182, and 186. In an alternative configuration, the inner member 192 is formed with a conductive material and functions as the first electrode. In this configuration, the elongated body 196 is covered with an  
30                   insulating material such as a sheath or a coating. The delivery portion 194 can be placed into electrical communication with tissue.

                  Yet another alternative embodiment, as shown in Figure 9, has an inner member 198 that does not form a delivery lumen. Rather, the agent 206 is coated on the surface of a needle 200 that is operably connected to the end 202 of an  
35                   elongated body 204. In this embodiment, the needle 200 functions as the first electrode 160. This embodiment also has advantages. For example, natural diffusion of the agent 206 is limited and thus more accurately controlled through

iontophoresis. Additionally, a smaller needle can be used, which enables more precision in reaching the abnormal cardiac tissue.

Figure 10 illustrates another alternative embodiment that has a guiding member 208 in the form of a catheter. The guiding member 208 forms a lumen 210. A needle 212 is slidably positioned within the lumen 210. The inner member 222 is formed from a stylet or deployment wire. The inner member 222 has a distal end 224 that is operably connected to the needle 212 and a proximal portion (not shown) that extends from the guiding member 208. A gripping member (not shown) such as a handle or collar is operably connected to the proximal portion of the inner member 222. The needle 212 functions as the first electrode 160, and the inner member 222 functions as a lead that provides electrical communication between the needle 212 and the power supply.

The needle 212 has a configuration similar to the other needles described herein, including a shaft 214 protected with an insulating material 216 and a delivery zone 218 that defines outlet ports 220. The insulating material can be a sheath or a coating. There is a gasket or some other type of sealing mechanism between the outer surface 216 of the needle 212 and the inner surface 228 of the lumen 210. In one possible configuration, the insulating material on the shaft 214 engages the wall of the lumen 210 and provides a seal. The seal prevents agent from flowing out the distal tip 230 of the guiding member 208. In this configuration, the caregiver can inject a fluid into the lumen 210. The fluid will then flow into the needle 212 and through the outlet ports 220.

Referring to Figure 11, another alternative embodiment has a guiding member 232 that defines an inflation lumen 234 and a deployment lumen 236. The guiding member 232 has a distal end 242 to which a balloon 238 is operably connected. The balloon 238 is in fluid communication with the inflation lumen 234 and, when in an inflated state, has a diameter greater than the guiding member 232. An outlet port 240 is defined in the wall of the guiding member 232 and is in fluid communication with the deployment lumen 236. The outlet port 240 is proximal to the distal tip 242 of the guiding member 232. In an alternative embodiment, the balloon 238 is positioned on the proximal side of the outlet port 240 rather than at the tip 242 of the guiding member 232. At least one radio opaque marker (not shown) is located on the outer surface 244 of the guiding member 232 so that the caregiver can determine the position and orientation of the outlet port 240. One possible configuration has two radio opaque markers spaced around the circumference of the guiding member 232 and proximal to the distal tip 242 of the guiding member 232.

A needle 246, which is illustrated in the deployed position, is slidably positioned within the deployment lumen 236 and has a configuration similar to the other needles described herein. The needle 246 is flexible and bends as it is deployed through the outlet port 240. The needle 246 can have any of the needle configurations described herein. The needle 246 is operably connected to an inner member 248 such as a stylet or deployment wire. As described below, this embodiment is advantageous for accessing the heart muscle through a coronary arterial wall.

Other configurations could include multiple delivery lumens and multiple needle/inner member assemblies. The caregiver could also simultaneously deliver agent to several locations of the heart muscle. In another possible configuration, the elongated body does not define an inflation lumen or include a balloon. Rather, the device is configured to deploy a needle through the distal end as well as through the wall of the guiding member. An advantage of these configurations is that the caregiver can deliver an agent to different points of the heart muscle without adjusting the position of the delivery device.

Referring to Figure 1, 2, and 3, when using the delivery device for cardiac ablation, the caregiver initially maps the electrical activity or cardiac impulses in the patient's heart 100 using techniques such as electrophysiological mapping. The caregiver uses this mapping to identify the location of reentry circuits 132. Such mapping can be performed with a variety of mapping catheters or other probes placed in, or adjacent to, the patient's heart 100.

The catheter or probe has a monitoring electrode that records a signal when in the presence of an electrical field generated by the heart's 100 electrical activity. In one possible embodiment of the delivery device, the first electrode 160 functions as a first monitoring electrode. An electrically conductive band (not shown) is wrapped around the guiding member 134 and proximal to the distal end 136. The electrically conductive band functions as a second monitoring electrode. This configuration provides detailed mapping of electrical activity in the heart 100 at a local level.

When monitoring the electrical activity of the heart 100, the electrically conductive band is in electrical communication with monitoring equipment. The lead 156 is also placed into electrical communication with the monitoring equipment. The monitoring equipment can then detect a differential signal that is indicative of the electrical activity of the heart 100. Once the reentry circuit is located, the first lead 156 is placed into electrical communication with the power supply 158 for delivery of the agent.

In an alternative configuration, there are two conductive bands wrapped around the guiding member 134 and positioned proximal the distal end 136. The two conductive bands function as first and second monitoring electrodes. Electrical activity of the heart 100 then can be monitored without use of the needle 148.

An electrically conductive band (not shown) is wrapped around the guiding member 134 and set back from the distal end 136. The electrically conductive band is a second monitoring electrode. This configuration provides detailed mapping of electrical activity in the heart on a local level.

In order to map the electrical activity of the heart 100, the caregiver threads the guiding member 134 through the circulatory system into either the right 104 and 108 or left 102 and 106 chambers of the heart 100. The caregiver then threads the inner member 140 through the guiding member 134 until the needle 148 is deployed from the distal tip 136 of the guiding member 134. The monitoring electrode is also connected to monitoring equipment via the first lead 156. In this configuration, the first electrode 160 functions as a monitoring electrode. The monitoring equipment either records the electrical activity of the heart 100 or displays the electrical activity on a screen. The caregiver uses this information to map the electrical activity of the heart 100 and identify the location of a reentry circuit 132.

The caregiver maneuvers the first electrode 160 to various positions along the cardiac muscle and maps the electrical activity to identify the location of the reentry circuit 132. The caregiver then places the needle 148 adjacent to the reentry circuit 132 and inserts the needle 148 deep into the cardiac muscle so that the agent will be distributed between the inner and outer surfaces of the muscle. The needle 148 can either be positioned in the center of the reentry circuit 132 or adjacent to the reentry circuit 132 with the outlet ports 150 facing the reentry circuit 132.

After the needle 148 is positioned, the caregiver injects and phoretically transports a reversible blocking agent that will temporarily block electrical conduction within the tissue. Examples of such a reversible agent include adenosine, anesthetic agents, and electrolytes. The caregiver then attempts to induce a tachycardia by electrically stimulating the heart 100. If a tachycardia is not induced, the caregiver has accurately reached the site of the reentry circuit 132 and permanent chemical ablation can proceed. If a tachycardia is induced, the caregiver knows that the reentry circuit is in a different position, or that there is a second reentry circuit 132. The caregiver can then relocate or adjust the position of the



needle 148 and re-inject the reversible blocking agent. This procedure is repeated until the caregiver has identified the reentry circuit 132.

The use of a reversible blocking agent has many advantages. Because the temporary block is fully reversible, tissue initially tested and found to be outside the reentry circuit 132 is not irreversibly damaged. Initial testing with a reversible pharmaceutical agent allows precise location and ablation of only abnormal tissue while sparing normal tissue. As a result, repeated ablation and damage to the healthy, normal cardiac tissue is avoided, and the health of patients already suffering from myocardial failure or other cardiac dysfunctions is not further compromised.

When the reentry circuit 132 is identified, the caregiver will ablate the tissue associated with the reentry circuit 132. Ablation is accomplished by injecting an agent through the delivery lumen 146 and outlet ports 150 in the needle 148. The agent is then iontophoretically transported to achieve a uniform and controlled distribution. Examples of agents that could be used to ablate cardiac tissue include ethanol, cytotoxic agents, neurotoxins, and fixatives such as glutaraldehyde, formaldehyde. Upon completion of the procedure, the inner and guiding members 140 and 134 are removed and the patient will continue through a post-electrophysiological recovery period.

The ablation agent is locally administered to an area that is large enough to ablate the tissue forming the reentry circuit 132, but also controlled to minimize the ablation of normal tissue. There are several techniques to control diffusion of the agent to minimize exposure of normal tissue to the ablation agent. One technique is to administer only a small volume of agent to limit the area in which the agent is diffused. Another technique is to limit the amount of current used during iontophoresis as well as the amount of time that the current is conducted between the first and second electrodes 160 and 166. Yet another technique is to deliver the agent in a gel. A gel with a relatively high viscosity will resist diffusion and thus remain substantially isolated to a controlled area.

Another way to minimize the exposure of the ablative agent to normal tissue is to use an agent that has a relatively short life. In this situation, the agent would become inactive by the time that it is diffused to normal cardiac tissue outside the area of the reentry circuit 132. The agent could have a short-half life. Alternatively, the agent could be sensitive to hydrolysis. The water in the heart would cause the hydrolysis-sensitive agent to breakdown and become inactive. The caregiver could use a combination of these or other techniques to minimize exposure of the ablative agent to normal tissue.

Referring to Figure 1, 2, and 9, yet another technique is to use the delivery device in which the needle 200 is coated with the agent. If this device is used, natural diffusion from the flow of the liquid agent is minimized, and thus the diffusion is more accurately controlled through the use of iontophoresis.

- 5 Additionally, a separate inner member is used for mapping the electrical activity of the heart 100 and for delivering a reversible blocking agent, if desired.

The delivery devices described herein are also useful for performing angiogenesis, which is a procedure of stimulating the growth of new blood vessels. The growth of vessels are stimulated by angiogenesis agents delivered directly into  
10 the cardiac muscle using the delivery techniques substantially similar to those outlined above. Examples of angiogenesis agents include vascular endothelial growth factor, basic and acidic fibroblast growth factors, and genes that code for these agents. Genes may represent naked gene plasmids, plasmid-lipid formulations, or viral vectors.

- 15 A blocked artery can prevent or restrict the flow of blood to a large area of the cardiac muscle, which typically results in a zone of ischemia as described above. As a result, the angiogenesis agent is delivered to a relatively large area of the muscle in order to restore blood flow to the entire zone of ischemia, which is in contrast to the procedure for cardiac ablation. In fact, the caregiver may deliver  
20 agent to several different areas within the zone of ischemia or, if there are multiple blockages, to several different ischemic areas. For example, the caregiver might deliver an angiogenesis agent to several points within a zone of ischemia.

Delivery of the angiogenesis agent can be accomplished by delivering the agent from within the atria or ventricles as described above. Delivery of the  
25 angiogenesis agent can also be accomplished through the chest via an incision or percutaneous puncture.

- In an alternative technique, access to the heart muscle is through a coronary arterial wall. In this alternative technique, the caregiver inserts the delivery device shown in Figure 11 into the patient's circulatory system and threads the  
30 guiding member to the point of the blockage in the coronary artery. The distal tip 242 of the guiding member 232 is positioned adjacent to the blockage and oriented so that the outlet port 240 opens toward the heart wall. Radio opaque markers are used to ensure that the outlet port 240 opens toward the heart muscle. The balloon 238 is inflated, which provides stability to the guiding member 232 and prevents the  
35 guiding member 232 from shifting as the needle 246 is deployed. The caregiver then pushes the inner member 248, which deploys the needle 246 and causes the needle 246 to be inserted through the arterial wall and into the heart-muscle at the site of the blockage. An angiogenesis agent is then delivered and phoretically

transported in order to restore blood flow into the zone of ischemia from a point upstream from the blockage. In one possible method, this delivery is accomplished by injecting the needle 246 through the coronary arterial wall at a point adjacent to the blockage and guiding the needle 246 to a point that is underneath the blockage.

5                   This technique has several advantages. One advantage is that this technique provides for delivery of the angiogenesis agent at the site of the blockage, which is typically the site of the ischemia and the site where it is desired to stimulate new vessel growth in order to restore blood flow to the heart muscle. Another advantage is that the blockage provides a marker for the caregiver to easily locate the  
10 ischemia and hence the target area. Yet another advantage is that access through the arterial wall causes minimal trauma to the patient.

                  In an alternative technique, the caregiver uses a delivery device that can deploy multiple needles. Using such a device is advantageous because the caregiver can deliver agent to several areas of the ischemia without moving the  
15 guiding member. As a result, delivery of the angiogenesis agent is quicker and trauma to the patient is minimized. In yet other alternative techniques, the caregiver can access the treatment area through the chambers of the heart as described herein, through a minimally invasive puncture in the chest, or through an open chest surgery. When using any of these alternative techniques, the caregiver can use any  
20 of the embodiments of the delivery devices described herein, including the device capable of deploying multiple needles.

                  Although the methods are described in terms of particular delivery device, it is to be understood that the methods could be practiced using a variety of different delivery device including the other embodiments that are described herein.

25                   Iontophoresis is accomplished by providing a voltage gradient, and resulting electrical current, between the first and second electrode. The voltage gradient causes the agent to migrate to the abnormal tissue. The current passed between the two electrodes has a net flow in one direction in order to transport the agent from a position directly adjacent to the tissue to the abnormal tissue. The  
30 current can be direct or have a variety of waveforms. Examples of various wave forms are described in United States Patent 5,499,971, which is entitled Internal Iontophoresis Drug Delivery Apparatus and Method and issued on March 19, 1996, the disclosure of which is hereby incorporated by reference.

                  In an alternative method, the current is an varying waveform, such as  
35 an alternating current, that has a net flow of current in one direction. An advantage of this method is that varying waveform may enhance cellular uptake and increase efficiency of the agent delivery.

In yet another alternative embodiment, a direct current or other waveform is used to transport the agent to the abnormal tissue. The current is then switched to a varying current to enhance cellular uptake. In one possible configuration, the varying current has a reduced net flow. In another possible configuration, the varying waveform has no net flow. An advantage of switching between waveforms in this manner is that a direct current will efficiently and quickly transport the agent. Once the agent is distributed throughout the desired target area, the varying waveform may enhance cellular uptake.

Additionally, the heart 100 is least susceptible to arrhythmia during the refractory period of the heart beat, which is that period between ventricular depolarization and repolarization of the heart. Thus, the risk of inadvertently inducing an arrhythmia can be reduced by synchronizing the electric current with the refractory period.

If the heart beat is irregular, the caregiver can pace the heart beat by sending a pulse into the heart 100 that would cause the heart 100 to depolarize and initiate beat. The caregiver could then more accurately synchronize the iontophoretic current to the refractory period of the heart beat. Synchronization to and pacing of the heart beat is described in more detail in United States Patent 5,634,899, which is entitled Simultaneous Cardiac Pacing and Local Drug Delivery Method and issued on June 3, 1997, the disclosure of which is hereby incorporated by reference.

Alternative methods for accessing the heart 100 and delivering an agent to the tissue in the cardiac muscle are possible. In one alternative, for example, the heart is access through a puncture or incision in the chest rather than through the circulatory system. In another example, an active transport mechanism such as phonophoresis or magnetophoresis is used rather than iontophoresis.

The various embodiments described above are provided by way of illustration only and should not be construed to limit the invention. Those skilled in the art will readily recognize various modifications and changes that may be made to the present invention without strictly following the example embodiments and applications illustrated and described herein, and without departing from the true spirit and scope of the present invention, which is set forth in the following claims. For example, a design may include elements or configuration not described herein, but still embody the claimed invention. A design might also include a combination of elements or configurations described in conjunction with the different embodiments that are set forth herein.

The claimed invention is:

1. An apparatus for delivering an agent directly into a cardiac muscle, the apparatus comprising:

- 5 a guiding member, the elongated member defining a deployment lumen and a distal tip;
- a hollow needle configured to be inserted into the cardiac muscle, the needle being operably connected to the guiding member, the needle having a side portion and defining an outlet port in the side portion; and
- 10 first and second electrodes, the first and second electrodes configured to be electrically connected to a power supply, the first electrode positioned to be in direct electrical communication with agent flowing through the outlet port.

15 2. The apparatus of claim 1 wherein the needle is operably connected to an inner member, the needle and inner member slidably engaging the deployment lumen.

20 3. The apparatus of claim 2 wherein the inner member is a stylet and the needle is in fluid communication with the deployment lumen.

25 4. The apparatus of claim 2 wherein the inner member is a catheter, the catheter defining a delivery lumen, the delivery lumen being in fluid communication with the needle.

5. The apparatus of claim 1 wherein the needle has an elongated shaft and slidably engages the deployment lumen.

30 6. The apparatus of claim 1 wherein the elongated member is rigid.

7. The apparatus of claim 1 wherein the guiding member is flexible and configured for accessing the cardiac muscle through the circulatory system.

8. The apparatus of claim 1 wherein the guiding member is rigid.

35 9. The apparatus of claim 1 wherein the guiding member is a cannula.

10. The apparatus of claim 1 wherein the needle has a helical configuration.

11. The apparatus of claim 1 wherein the needle is straight.

5

12. The apparatus of claim 1 wherein the needle is formed from Nitinol, the needle having a first state in which the needle is straight and a second state in which the needle is not straight.

10 13. The apparatus of claim 1 wherein the needle defines a plurality of outlet ports.

14. The apparatus of claim 13 wherein the outlet ports are slots defined in the needle.

15

15. The apparatus of claim 1 wherein the needle has an electrically conductive material and forms the first electrode.

16. The apparatus of claim 1 wherein the guiding member defines an outlet port, the hollow needle being deplorable from the outlet port.

20

17. The apparatus of claim 16 wherein the outlet port is positioned at the distal tip of the guiding member.

18. The apparatus of claim 16 wherein the outlet port is positioned in the side of the guiding member.

25

19. The apparatus of claim 18 wherein the guiding member defines an inflation lumen, the apparatus further comprising a balloon operably connected to the elongated member, the balloon being in fluid communication with the inflation lumen.

30

20. A method of delivering an agent directly into a cardiac muscle, the method comprising the steps of:

35

introducing an elongated body into the patient, the elongated body having a needle at its distal tip.

inserting the needle into the cardiac muscle, the needle being configured to deliver the agent; and

iontophoretically transporting the agent into cardiac tissue proximal to the needle.

21. The method of claim 20 wherein the cardiac muscle has a cardiac  
5 cycle, the step of iontophoretically transporting the agent includes the steps of:  
monitoring the electrical activity of the cardiac muscle;  
passing an electrical current into the cardiac muscle; and  
synchronizing the electrical current within the cardiac cycle to  
minimize the risk of inducing arrhythmia.

10

22. The method of claim 20 wherein the cardiac muscle has a cardiac  
cycle, the step of iontophoretically transporting the agent includes the steps of:  
monitoring the electrical activity of the cardiac muscle;  
passing an electrical current into the cardiac muscle;  
15 supplying a pacing pulse into the cardiac muscle initiating at least one  
cardiac cycle; and  
synchronizing the electrical current within the remaining portion of  
the cardiac cycle to reduce the risk of inducing arrhythmia.

20

23. The method of claim 20 wherein the needle has a helical shape and  
the step of inserting the needle includes the step of screwing the needle into the  
cardiac muscle.

24. The method of claim 20 wherein the needle is formed with an  
25 electrically conductive material thereby forming a first electrode, the first electrode  
and a second electrode being in electrical communication with a power supply, the  
step of iontophoretically transporting the agent into cardiac tissue includes the step  
of applying a voltage gradient between the first and second electrodes.

30

25. The method of claim 20 further comprising the steps of:  
mapping the electrical activity of the cardiac muscle before inserting  
the needle into the cardiac muscle;  
determining the location of a reentry circuit; and  
wherein the step of inserting the needle includes the step of inserting  
35 the needle proximal to the reentry circuit.

35

26. The method of claim 25 wherein the step of injecting the agent  
includes the steps of:

injecting a reversible blocking agent;  
attempting to induce a tachycardia in the cardiac muscle; and  
injecting an ablation agent if a tachycardia is not induced.

5           27.    The method of claim 26 wherein the blocking agent is selected from  
the group consisting essentially of: adenosines, anesthetics, and electrolytes.

          28.    The method of claim 26 wherein the ablation agent is selected from  
the group consisting essentially of: ethanol, cytotoxins, fixatives, and neurotoxins.

10

          29.    The method of claim 20 wherein the agent promotes angio-genesis.

          30.    The method of claim 29 wherein the agent is selected from the group  
consisting essentially of: vascular endothelial growth factors, basic and acid  
15 fibroblast growth factors, and genes that code for growth factors.

          31.    The method of claim 20 wherein the elongated body is a catheter and  
the step of introducing an elongated body includes the step of introducing the needle  
and elongate body through the circulatory system and into a chamber of the heart.  
20

          32.    The method of claim 31 wherein the step of introducing the needle  
and elongate body through the circulatory system and into the chambers of the heart  
includes the steps of:

                  introducing a guiding member through the circulatory system and  
25                   into the chambers of the heart, the guiding member having a  
                  distal tip and defining a lumen; and  
                  threading the needle and elongate member through the lumen of the  
                  guiding member until the needle is deployed from the distal  
                  tip of the guiding member.



FIG. 1

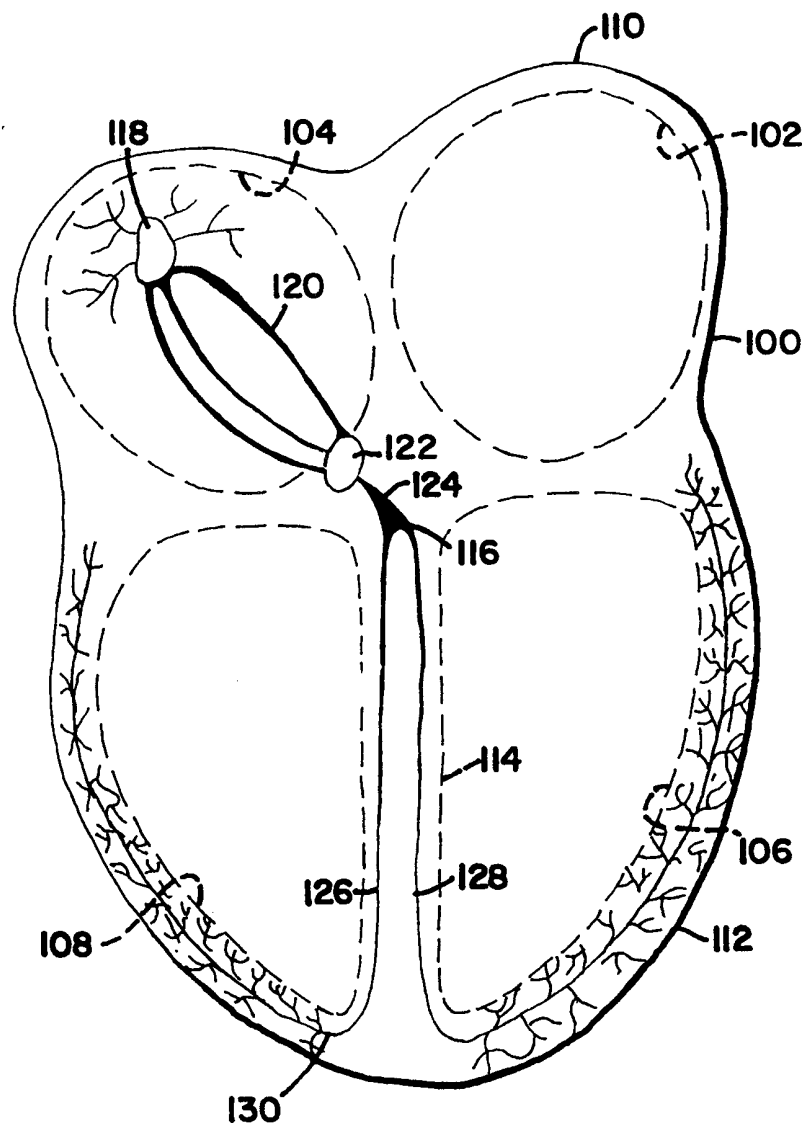

**FIG. 2**

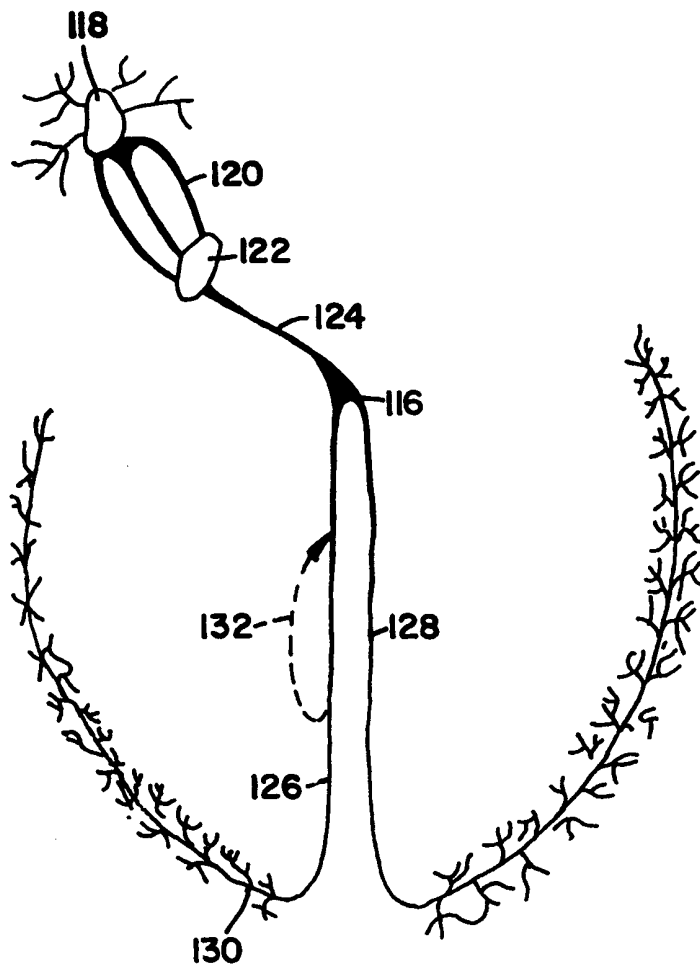

**FIG. 3**

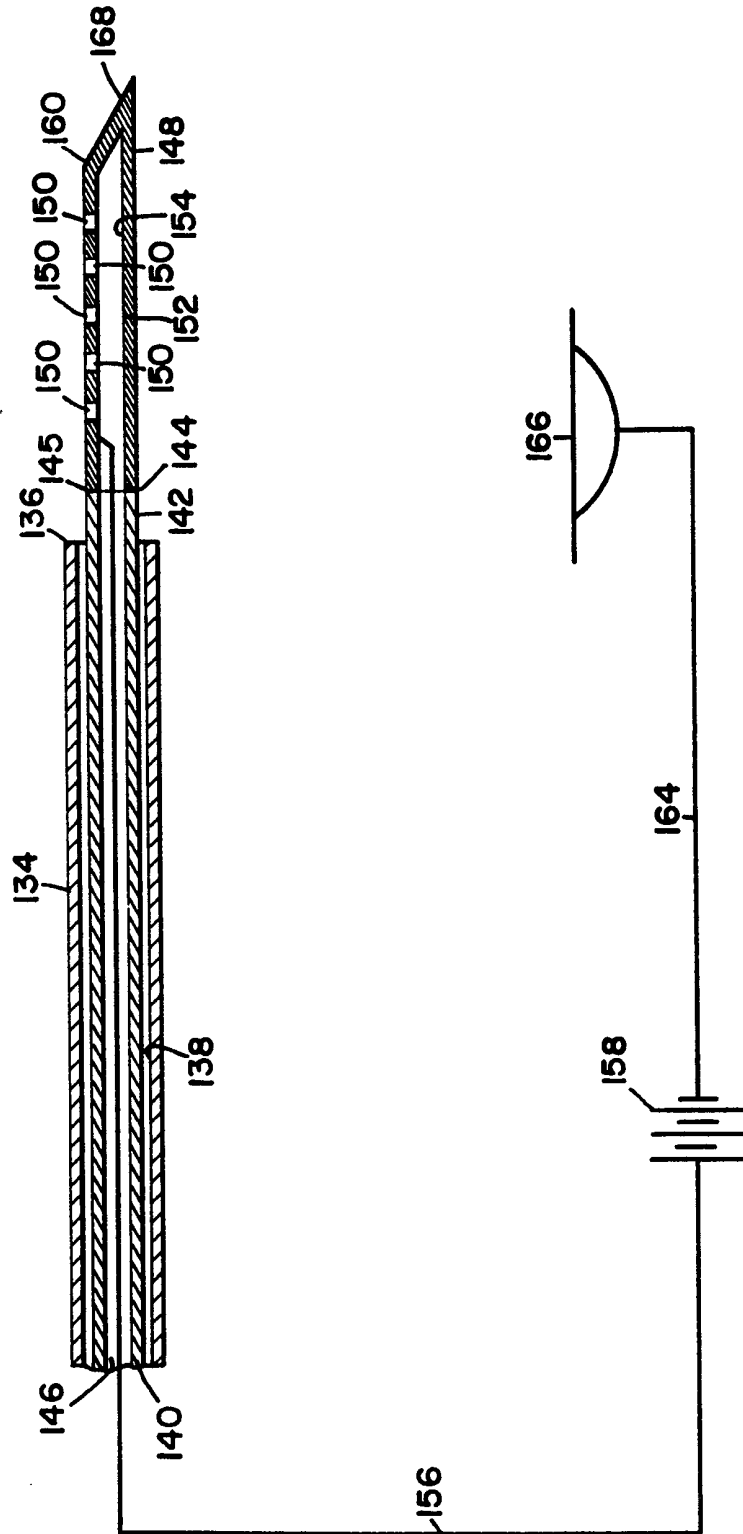

FIG. 4

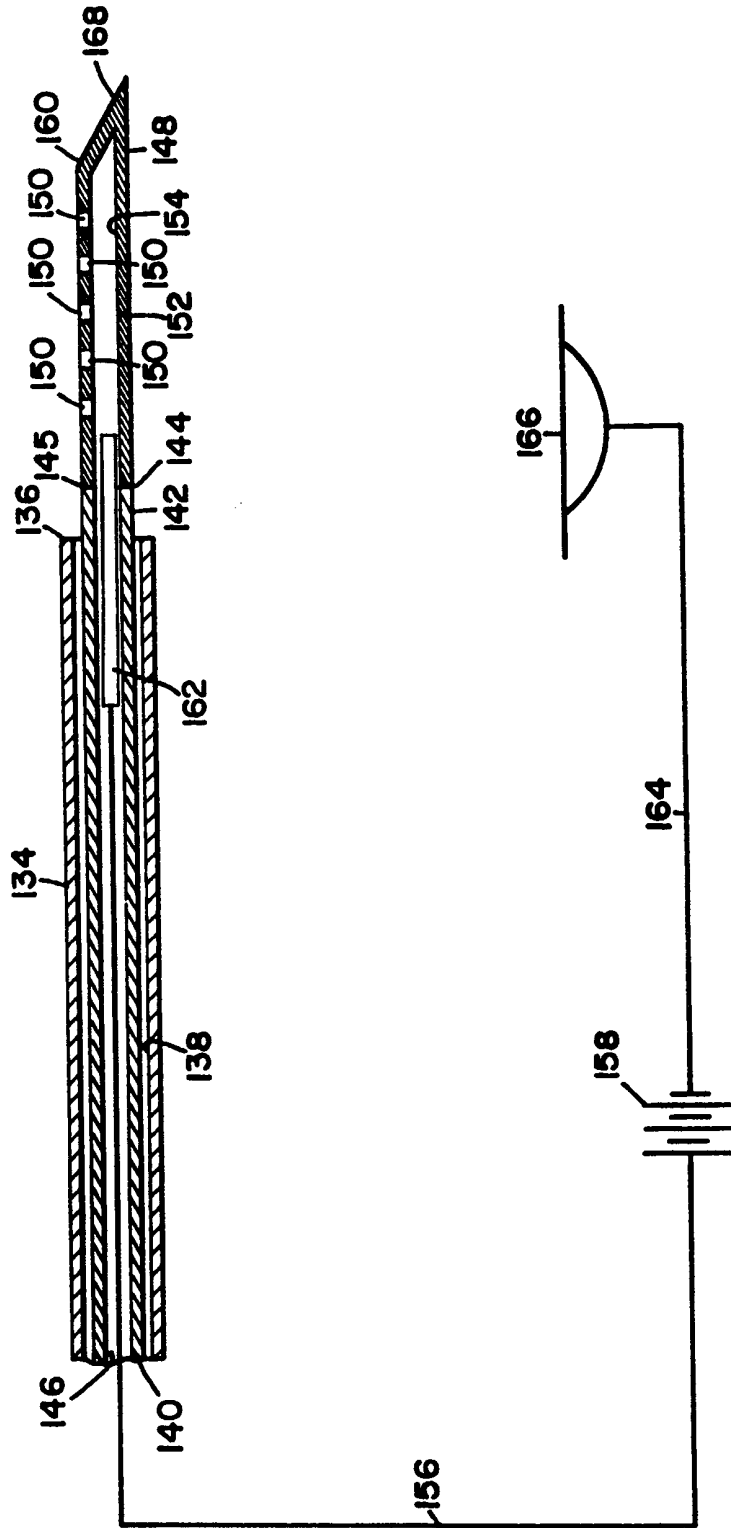

FIG. 5

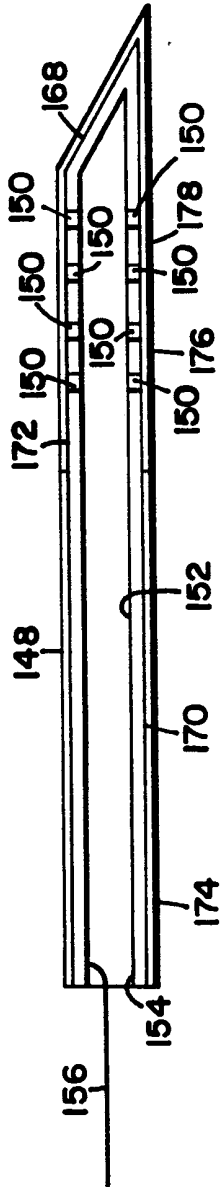

FIG. 6

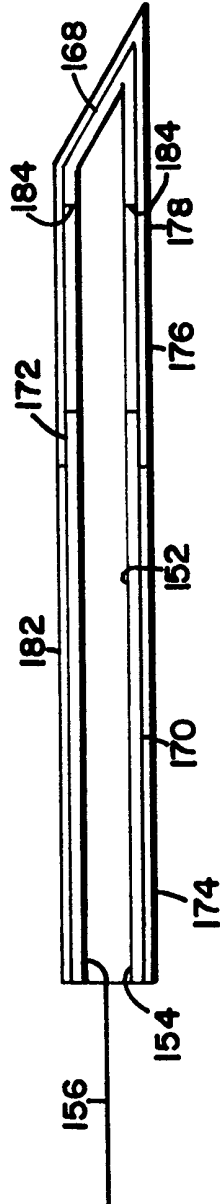
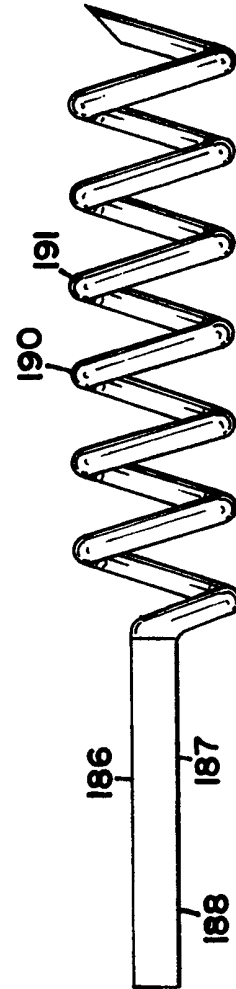
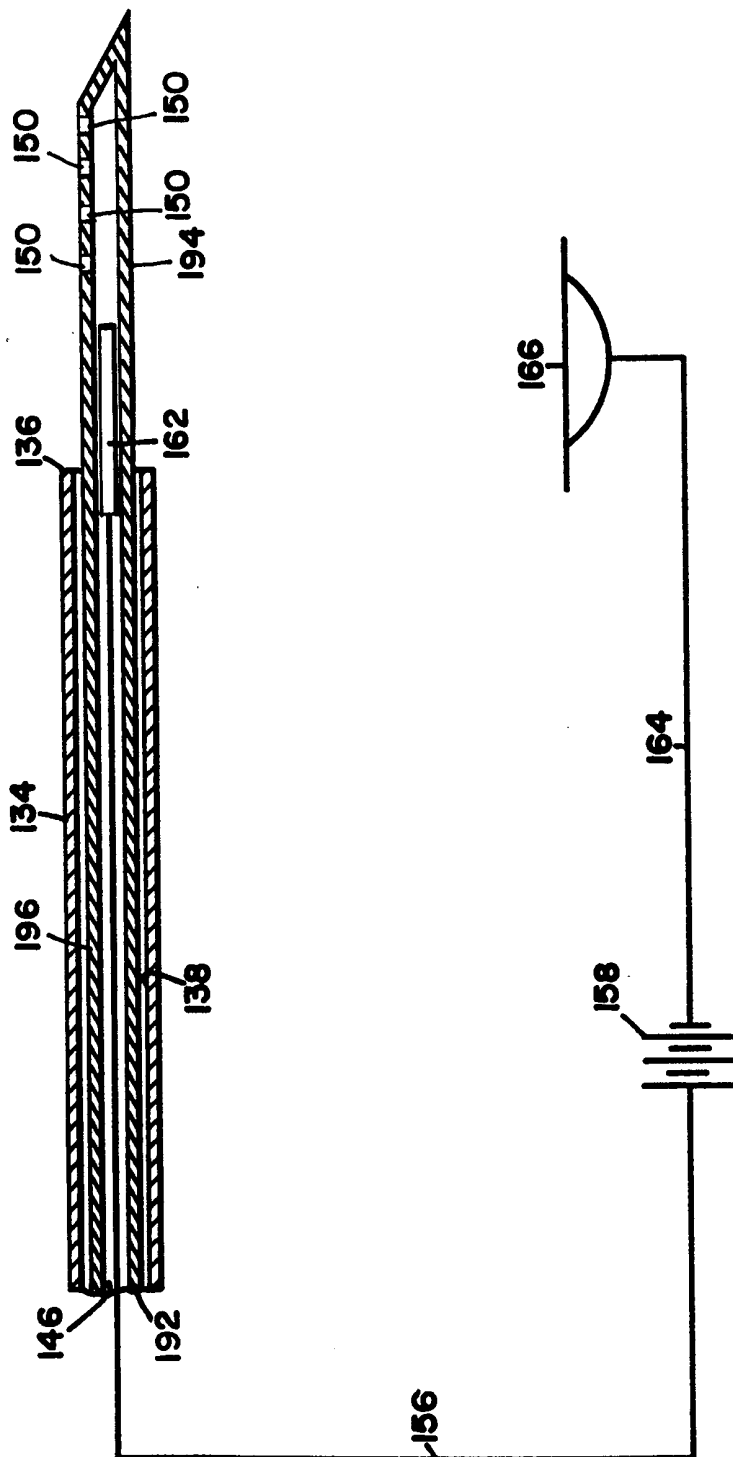

FIG. 7



**FIG. 8**



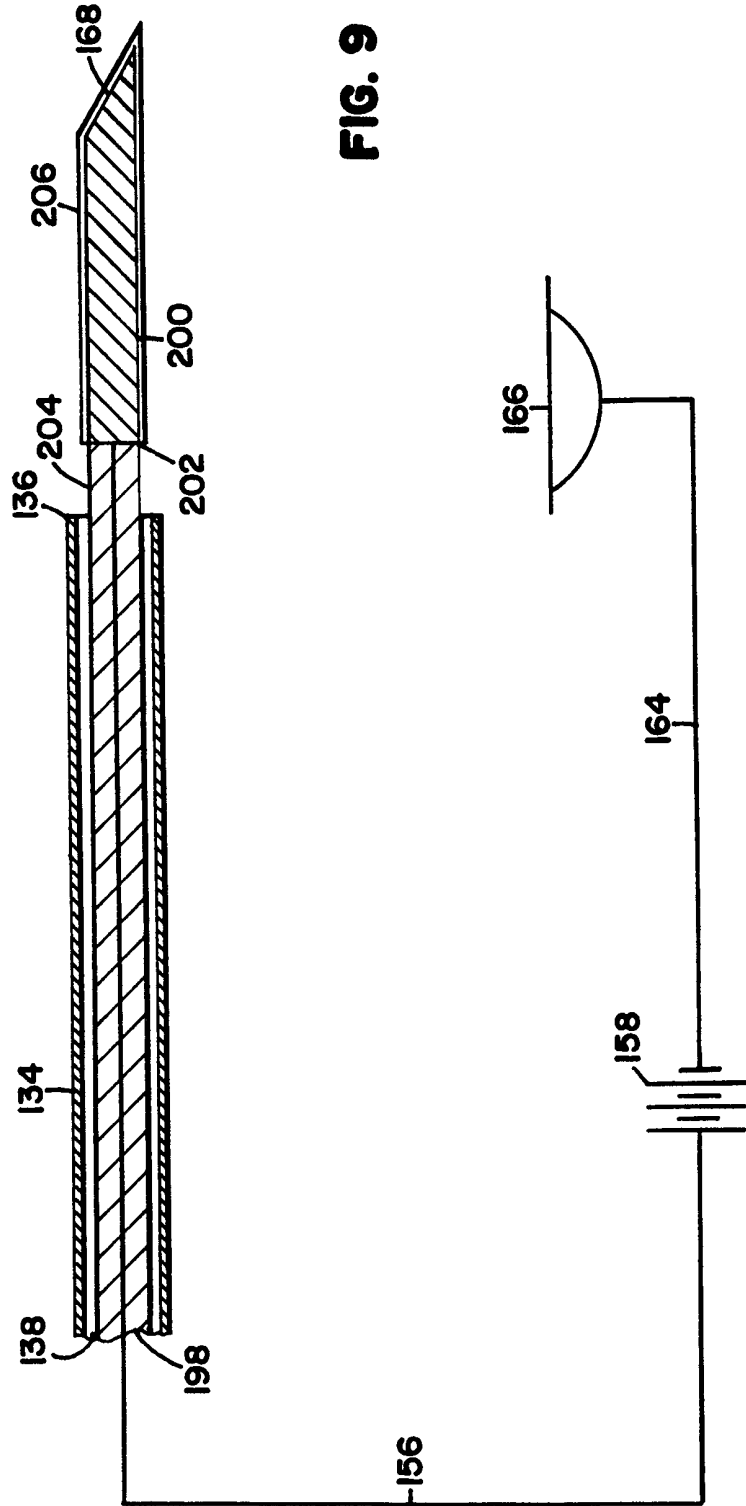
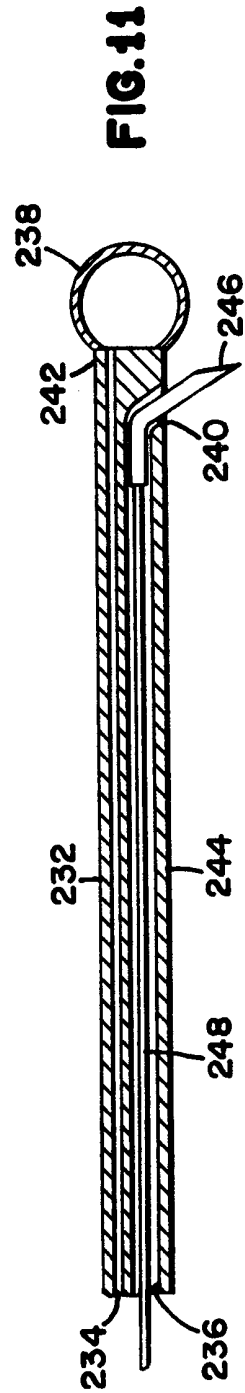
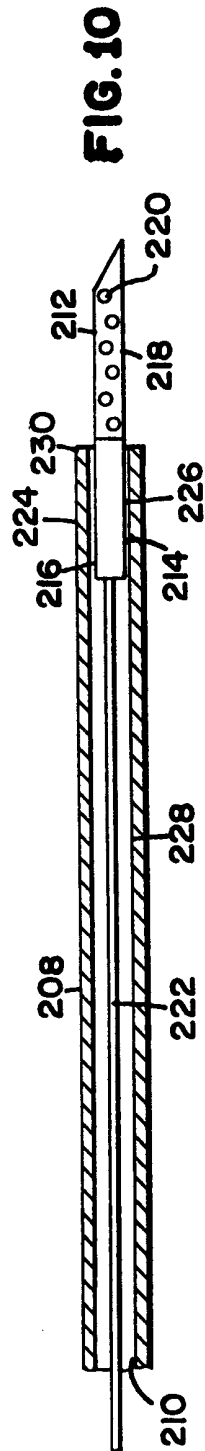

FIG. 9





# INTERNATIONAL SEARCH REPORT

International Application No

PCT/US 98/15051

**A. CLASSIFICATION OF SUBJECT MATTER**

IPC 6 A61N1/30

According to International Patent Classification (IPC) or to both national classification and IPC

**B. FIELDS SEARCHED**

Minimum documentation searched (classification system followed by classification symbols)

IPC 6 A61M A61N

Documentation searched other than minimum documentation to the extent that such documents are included in the fields searched

Electronic data base consulted during the international search (name of data base and, where practical, search terms used)

**C. DOCUMENTS CONSIDERED TO BE RELEVANT**

Category	Citation of document, with indication, where appropriate, of the relevant passages	Relevant to claim No.
X	US 5 405 376 A (MULIER PETER M J ET AL) 11 April 1995 see the whole document ---	1,7,10, 13-15
A	FR 2 365 351 A (BENHAIM JEAN) 21 April 1978 see the whole document ---	1-3,5-7, 11,16-18
A	US 5 419 777 A (HOFLING BERTHOLD) 30 May 1995  see column 2, line 19 - line 35 see column 3, line 34 - line 37 see column 4, line 9 - line 14 ---  -/--	1,2,4-9, 11,12, 16-19

Further documents are listed in the continuation of box C.

Patent family members are listed in annex.

Special categories of cited documents :

- "A" document defining the general state of the art which is not considered to be of particular relevance
- "E" earlier document but published on or after the international filing date
- "L" document which may throw doubts on priority claim(s) or which is cited to establish the publication date of another citation or other special reason (as specified)
- "O" document referring to an oral disclosure, use, exhibition or other means
- "P" document published prior to the international filing date but later than the priority date claimed

- "T" later document published after the international filing date or priority date and not in conflict with the application but cited to understand the principle or theory underlying the invention
- "X" document of particular relevance; the claimed invention cannot be considered novel or cannot be considered to involve an inventive step when the document is taken alone
- "Y" document of particular relevance; the claimed invention cannot be considered to involve an inventive step when the document is combined with one or more other such documents, such combination being obvious to a person skilled in the art.
- "&" document member of the same patent family

Date of the actual completion of the international search

10 November 1998

Date of mailing of the international search report

16/11/1998

Name and mailing address of the ISA

European Patent Office, P.B. 5818 Patentlaan 2  
NL - 2280 HV Rijswijk  
Tel. (+31-70) 340-2040, Tx. 31 651 epo nl,  
Fax: (+31-70) 340-3016

Authorized officer

Petter, E

# INTERNATIONAL SEARCH REPORT

International Application No  
PCT/US 98/15051

C.(Continuation) DOCUMENTS CONSIDERED TO BE RELEVANT		
Category	Citation of document, with indication, where appropriate, of the relevant passages	Relevant to claim No.
A	US 4 578 061 A (LEMELSON JEROME H) 25 March 1986 see column 5, line 33 - line 43; figure 5 see column 8, line 16 - column 9, line 35; figure 6 <p style="text-align: center;">-----</p>	1-3,5,7, 11,16-18

# INTERNATIONAL SEARCH REPORT

Information on patent family members

International Application No

PCT/US 98/15051

Patent document cited in search report	Publication date	Patent family member(s)	Publication date
US 5405376      A	11-04-1995	AU 676767 B	20-03-1997
		AU 7630294 A	21-03-1995
		CA 2168660 A	02-03-1995
		DE 69406941 D	02-01-1998
		DE 69406941 T	25-06-1998
		EP 0719162 A	03-07-1996
		JP 8508917 T	24-09-1996
		WO 9505867 A	02-03-1995
		-----	
FR 2365351      A	21-04-1978	NONE	
-----			
US 5419777      A	30-05-1995	DE 4408108 A	14-09-1995
		AT 165740 T	15-05-1998
		AU 684542 B	18-12-1997
		AU 7614494 A	25-09-1995
		BG 100828 A	30-04-1997
		BR 9408549 A	19-08-1997
		CA 2184388 A	14-09-1995
		CN 1143326 A	19-02-1997
		CZ 9602553 A	12-03-1997
		DE 59405922 D	10-06-1998
		WO 9524235 A	14-09-1995
		EP 0738165 A	23-10-1996
		ES 2118431 T	16-09-1998
		FI 963458 A	04-09-1996
		HU 76019 A	30-06-1997
		JP 9509865 T	07-10-1997
		LV 11733 A	20-04-1997
		LV 11733 B	20-08-1997
		NO 963659 A	03-09-1996
		PL 316201 A	23-12-1996
SG 46563 A	20-02-1998		
SI 9420081 A	28-02-1997		
SK 115796 A	09-07-1997		
-----			
US 4578061      A	25-03-1986	US 4588395 A	13-05-1986
		US 4900303 A	13-02-1990
		US 4803992 A	14-02-1989
-----			