



(51) International Patent Classification:

A61F 2/44 (2006.01) A61F 2/28 (2006.01)
A61B 17/70 (2006.01)

(21) International Application Number:

PCT/US2013/062502

(22) International Filing Date:

28 September 2013 (28.09.2013)

(25) Filing Language:

English

(26) Publication Language:

English

(30) Priority Data:

61/744,525 28 September 2012 (28.09.2012) US
14/039,660 27 September 2013 (27.09.2013) US

(71) Applicant: **GLOBUS MEDICAL, INC.** [US/US]; Valley Forge Business Center, 2560 General Armistead Avenue, Audubon, Pennsylvania 19403 (US).

(72) Inventor: **GORDON, Jeffrey David**; 3850 Gradyville Road, Newtown Square, Pennsylvania 19073 (US).

(74) Agent: **CASTELLANO, Kristina**; Castellano PLLC, P.O. Box 1555, Great Falls, Virginia 22066 (US).

(81) Designated States (unless otherwise indicated, for every kind of national protection available): AE, AG, AL, AM, AO, AT, AU, AZ, BA, BB, BG, BH, BN, BR, BW, BY, BZ, CA, CH, CL, CN, CO, CR, CU, CZ, DE, DK, DM, DO, DZ, EC, EE, EG, ES, FI, GB, GD, GE, GH, GM, GT, HN, HR, HU, ID, IL, IN, IS, JP, KE, KG, KN, KP, KR, KZ, LA, LC, LK, LR, LS, LT, LU, LY, MA, MD, ME, MG, MK, MN, MW, MX, MY, MZ, NA, NG, NI, NO, NZ, OM, PA, PE, PG, PH, PL, PT, QA, RO, RS, RU, RW, SA, SC, SD, SE, SG, SK, SL, SM, ST, SV, SY, TH, TJ, TM, TN, TR, TT, TZ, UA, UG, US, UZ, VC, VN, ZA, ZM, ZW.

(84) Designated States (unless otherwise indicated, for every kind of regional protection available): ARIPO (BW, GH, GM, KE, LR, LS, MW, MZ, NA, RW, SD, SL, SZ, TZ, UG, ZM, ZW), Eurasian (AM, AZ, BY, KG, KZ, RU, TJ, TM), European (AL, AT, BE, BG, CH, CY, CZ, DE, DK, EE, ES, FI, FR, GB, GR, HR, HU, IE, IS, IT, LT, LU, LV, MC, MK, MT, NL, NO, PL, PT, RO, RS, SE, SI, SK, SM,

[Continued on next page]

(54) Title: DEVICE AND METHOD FOR TREATMENT OF SPINAL DEFORMITY

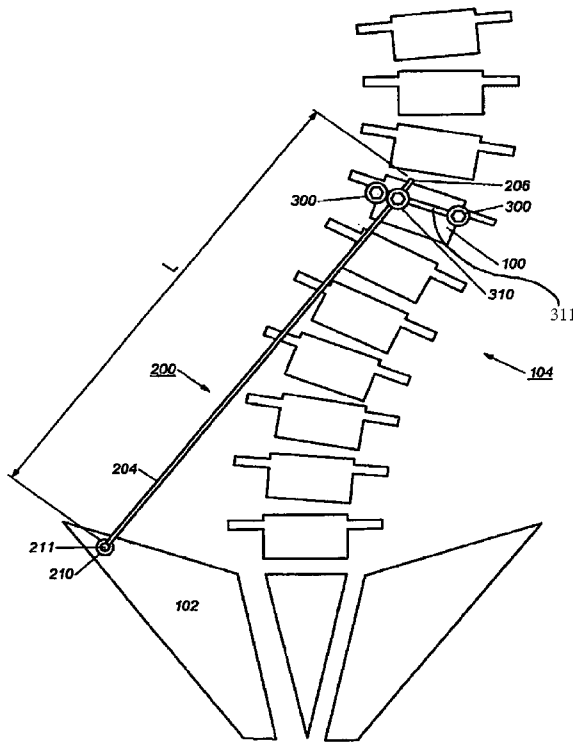

Fig. 1

(57) Abstract: The present invention generally relates to methods and device for treatment of spinal deformity, wherein at least one tether is utilized to maintain the distance between the spine and the an ilium to (1) prevent increase in abnormal spinal curvature, (2) slow progression of abnormal curvature, or (3) impose at least one corrective displacement and/or rotation.

WO 2014/052944 A1

TR), OAPI (BF, BJ, CF, CG, CI, CM, GA, GN, GQ, GW, KM, ML, MR, NE, SN, TD, TG). **Published:**

— with international search report (Art. 21(3))

DEVICE AND METHOD FOR TREATMENT OF SPINAL DEFORMITY

Cross-Reference to Related Applications

[0001] This Patent Application is non-provisional application which claims priority to U.S. Provisional Application Serial No. 61/744,525 filed on September 28, 2012, which is incorporated in its entirety herein.

Field of the Invention

[0002] The present invention generally relates to methods and devices for treatment of spinal deformity.

Background of the Invention

[0003] Scoliosis is a spinal deformity characterized by an abnormal curvature of the spine in the coronal plane. Adolescent idiopathic scoliosis (AIS) is the most prevalent type of scoliosis which develops during adolescence in an otherwise healthy patient and typically ceases at the onset of skeletal maturity. The cause of the disease is presently unknown.

[0004] Current surgical treatment of scoliosis involves manipulation of the spinal column and attachment of corrective devices for fusion of a portion of the spine. One such system, the Cotel-Dubousset system utilizes rigid metal rods attached to the spine. The rods are manipulated during surgery in an attempt to reduce abnormal curvatures and rotations of the spinal column. Large loads are exerted on the spine for correction which risks the patient's neurological condition. Recovery from these procedures can be lengthy and painful. Also, if normal lordosis and kyphosis are not restored, a condition called "flat back syndrome" may occur causing chronic pain. Even a successful procedure rarely results in a normal spinal curvature and the patient is left with an immobile spinal section. The discs above and below the fusion zone are at risk of future degeneration due to the increased mechanical demands placed on them.

[0005] It is therefore evident that there are flaws in prior art methods and devices. Most prior art devices are part of the load path of the spinal column. For example, it is understood that the Cotel-Dubgousset system rigidly attaches stiff metal rods to the spine. A structure having two roughly parallel support members relies primarily on the stiffer of the two members for transmission of loads. Therefore, loads exerted on an instrumented spine are transferred through the implant instead of through the spine. Spinal loads can be significantly large, and the implants

will not support such loads indefinitely. Fatigue failure of the implant will occur if fusion is delayed.

[0006] Therefore, there is an unaddressed need that exists to provide a new and better system for correcting spinal deformities.

Summary of the Invention

[0007] The current invention describes methods and devices for treating spinal deformity which offer significant improvements over prior art methods and devices. In general terms the present invention is used to secure the distance between an ilium and the spine to either correct or maintain spinal curvature. There are many embodiments of the invention which will achieve the stated objectives, some of which will be presented in the following summary.

[0008] In one embodiment of the invention, at least one device is attached between the spine and the pelvis which incorporates at least one flexible tether. Attachment of the flexible tether to the spine and ilium involves implantation of anchoring means and then attachment of the tether to the anchoring means. For example, at least one bone screw, pedicle screw, cannulated bone screw, clamp, plate, bone anchor, or shackle might be anchored to at least one vertebra and another to a portion of the ilium and the flexible tether may be attached to both. Other means of attachment will be clear to one practiced in the art. Alternatively, a loop of material may be placed around a bony structure (e.g. spinous process, transverse process, lamina or pars) or a hole through a bony structure through which the flexible tether is passed.

[0009] It should be noted that the present invention enables manipulating the vertebral column to correct the deformity by securing the tether to a portion of the ilium and a portion of the vertebral column; the ability to correct deformity by correcting the effective length of the tether between the ilium and vertebra over time; and correcting deformity by the natural growth of the spine by allowing the tether to maintain effective length between the vertebral column and the ilium.

[0010] Adjustment of the distance between the spine and ilium is achieved by varying the location at which the tether is attached to the anchoring means. The tether does not change lengths during the adjustment process, but the distance between the attachment points does, much like adjusting a belt around your waist. Taking advantage of the inherent viscoelasticity

of spinal structures, the curvature may be gradually corrected by small incremental corrections over a protracted period of time, whereby the original incision is re-opened, or a new incision next to the original incision is created and the attachment means is disengage and then reengaged at a different location along the tether. Alternatively the patient's growth may be used to achieve correction.

[0011] Alternatively, the tether may branch into multiple tethers to provide multiple attachments to the spine and/or ilium. If more than one tether is used, each can be attached to a different vertebra, or multiple tethers can be attached to the same vertebra. Tethers can be attached to either or both sides of the vertebral column and either opposing sides of ilium as needed to generate correction of the spinal deformity. A crossing pattern whereby a tether is attached to the right side of the vertebra (e.g. the right pedicle) and left ilia, or vice versa, is possible. Also, a tether may be attached to a vertebra and then passed through an eye screw or other guiding device which is attached to the ilium (or both ilia) and then attached to a second vertebra with a pedicle screw or other means. It can be envisioned by one skilled in the art that guiding devices may be utilized on a number of vertebrae or one the ilium or ilia. The tether may also originate with an attachment to the pelvis, pass through any number of guide members attached to the spine, and then terminate at the pelvis again.

[0012] These and other aspects of the present invention, will become apparent from the following description of the embodiments taken in conjunction with the following drawings, although variations and modifications therein may be affected without departing from the spirit and scope of the novel concepts of the disclosure.

[0013] The present invention provides an improved method of arresting a spinal deformity whereby at least one device is surgically attached between the spine and the ilium. Also, the present invention provides a system and a method for correcting a spinal deformity whereby at least one device is surgically attached between the spine and the ilium.

Brief Description of the Drawings

[0014] The present invention will become more fully understood from the detailed description and the accompanying drawings, wherein:

[0015] FIG. 1 is an illustration of a posterior view of a deformed human spine with an implanted device according to one embodiment of the present invention;

- [0016] FIG. 2 is an illustration of a posterior view of a corrected human spine with the implanted device shown in FIG. 1;
- [0017] FIG. 3 shows a spinal anchoring means in the form of two pedicle screws and a rod onto which is secure an attachment mechanism and the tether;
- [0018] FIG. 4 illustrates an attachment mechanism and the method of attaching it to the spinal anchoring mechanism;
- [0019] FIG. 5 shows the anchoring mechanism of the ilium (not shown) and the method of attaching the tether to it;
- [0020] FIG. 6 shows a long pair of forceps to be used for passing the tether beneath the skin;
- [0021] FIG. 7 illustrates the use of the forceps of Fig. 6 in passing the tether beneath the skin;
- [0022] FIG. 8 illustrates an alternative embodiment of the tether clamp and elongate rod according to the present invention;
- [0023] FIG. 9 illustrates another embodiment of a clamp or anchor according to the present invention;
- [0024] FIG. 10 shows a cross-sectional view of the device shown in FIG. 9;
- [0025] FIG. 11 shows another embodiment of a clamp or anchor according to the present invention;
- [0026] FIGS. 12 and 13 shows a closed head clamp according to the present invention;
- [0027] FIGS. 14 and 15 shows yet another embodiment of a closed head clamp according to the present invention; and
- [0028] FIGS. 16-18 illustrate various methods of coupling the tether to portions of the spine and/or ilium.

Detailed Description of the Preferred Embodiments

[0029] The following description of the preferred embodiment(s) is merely exemplary in nature and is in no way intended to limit the invention, its application, or uses. The invention being thus described, it will be obvious that the same may be varied in many ways. Such variations are not to be regarded as a departure from the spirit and scope of the invention, and all such modifications as would be obvious to one skilled in the art are intended to be included within the scope of the following claims.

[0030] Fig. 1 is an illustration of a posterior view of a deformed spine 104 whereby the preferred embodiment of the device 200 is attached to an ilium 102 and a vertebra 100. Device 200 includes a tether 204 having a free end 206 and that is configured to be attached to the ilium and a portion of the vertebra. Specifically, in one embodiment, two attachment mechanisms such as pedicle screws 300 are anchored to the vertebra of the spine by insertion into opposing pedicles, and a transverse rod 311 is attached to the pedicle screws 300. It should be noted that although pedicle screws are provided in this particular embodiment, any other type of anchoring mechanism such as hooks may also be used. A tether clamp 310 is attached to rod 311 and the tether 204 is passed through tether clamp 310 and then passed down to the ilium 102 thereby securing a connection between the attached vertebra and the ilium. To attach the tether 204 to the ilium 102, an ilium anchor 210 is provided. The ilium anchor 210 includes a bore 211 and is configured to be attached to the ilium by inserting the anchor 210 (threading) into a hole which has been drilled or punched through the ilium 102. It should be noted that any other similar mechanism to attach anchor 210 to the ilium 102 may also be utilized. Tether 204 is passed through hole or bore 211 in the ilium anchor 210 and then brought back to the vertebra 100 and passed again through the tether clamp 310. In other embodiments, the tether 204 may only be passed once through the tether clamp and ilium anchor 210.

[0031] Fig. 2 illustrates the correction of the spine of Fig. 1 using device 200. As illustrated in Fig. 2, the free end 206 of tether 204 is pulled and the spine is manually manipulated during the surgery to achieve a correction of the deformity. When a satisfactory curve magnitude is achieved, tether 204 is tightened within the tether clamp, effectively locking the distance between vertebra 100 and the ilium 102.

[0032] It should be noted that various levels of manipulation of the vertebral column can be coordinated using the device. For instance, different curvatures of the spine can be achieved by changing the position of the anchor and the clamp on the tether with respect to the vertebral column and the ilium. The locations along the tether where the clamp and anchor are attached determine an effective length of the tether, which in turn maximizes the distance that the attached vertebra may move relative to the position where the tether is attached at in the ilium. The scoliotic curve is corrected (or maintained) by adjusting the clamping and anchoring locations along the tether.

[0033] Fig. 3 shows a detailed view of pedicle screws 300, transverse rod 311, tether clamp 310 and tether 204. In a preferred embodiment tether clamp 310 includes locking screw 312 which clamps tether clamp 310 onto rod 311 as well as locking the tether 204 within the clamp 310.

[0034] Fig. 4 shows a detailed view of the tether clamp 310 coupled to the transverse rod. The tether clamp 310 is configured with a slot 501 which is provided through the tether clamp 310 and tether 204 is passed through slot 501. It should be noted that the tether may be passed through the slot multiple times, if necessary. Locking screw 312 is used to secure the transverse rod 311 onto the tether clamp 310 and applies a compressive force upon the rod 311 onto the tether 204, thereby clamping the tether 204 securely in place. It should be noted that although a threaded set screw is utilized in the present embodiment, any type of locking element known in the art for securing the tether within tether clamp may be used.

[0035] Fig. 5 shows a detailed view of an ilium anchor 210. Ilium anchor 210 includes threads 212 for engagement with ilium 102(not shown). Tether 204 is passed through bore 211 and then passed back to the vertebral column. A collar 215 is shown which keeps tether 204 adjacent to itself.

[0036] Fig. 6 shows an extra-long pair of forceps 900. Fig. 7 shows the preferred method of passing the tether through an incision 845 and underneath skin and other soft tissues. The forceps 900 are used to pass the tether through the openings in the tether clamp and used to tension the tether to correct the deformity of the curvature in the spine.

[0037] Fig. 8 illustrates another embodiment of a tether clamp 320 according to the present invention. In this embodiment, the tether clamp 320 is configured with a through hole 322 that is configured to correspond to a through hole 324 in an elongate rod 326 that is fixated to a portion of the spinal column. A fastening element 328 such as a set screw is provided to couple the tether clamp 320 and the elongate rod 326 together. The tether clamp 320 also includes openings 330, 332 which are dimensioned to receive and securely couple a tether 334 to the clamp 320. The tether 334 is pulled through each of the openings 330, 332 to securely attach the tether 334 to the clamp 320 and the elongate rod 326.

[0038] Figs. 9 and 10 illustrate an alternative embodiment of a clamp and/or anchor 250 that can be used to secure a tether 252 to either the vertebral column or a portion of the ilium. More specifically, the anchor 250 of Figs. 9 and 10 may be configured and dimensioned to be attached

to a portion of the vertebral column or may be configured to secure the tether to the ilium. The anchor 250 is configured as a plate 251 having at least two openings 254, 256 to receive fasteners 258, 260 capable of fixating the plate to bone. The plate 251 includes a middle portion 262 having an opening 264 that is capable of receiving the tether 252. The middle portion 262 of the plate 251 is further provided with a fastening element 266 to secure the tether 252 to the plate 251. As more clearly illustrated in Fig. 10, the fastening element 266 may be a set screw which directly contacts the tether 252 when tightened to secure the tether 252 to the plate 251. It should be noted that any other type of fastening element which is capable of securing the tether to the anchor may be used, such as a pin.

[0039] Fig. 11 illustrates yet another embodiment of a clamp or anchor 400 according to the present invention. In this embodiment, the clamp and/or anchor 400 includes a first plate 402 and second plate 404 that are secured to one another via a fastening element 406. The first and second plates 402, 404 may also include spikes 408 or similar type of features that bite into bone. Either the first or second plate 402, 404 or both also includes an opening 410 for receiving a tether. The first and second plates 402, 404 are positioned so that bone is in between, such as the ilium or a portion of the vertebral column. As the first and second plates 402, 404 are compressed into bone, the tether which is positioned through the opening 410 and in between the first and second plates 402, 404, is also securely locked between the plates and the bone thereby securing the tether to the plates 402, 404. In an alternative embodiment, the tether is passed through the opening and secured to the anchor 400 by a clamp device such as a belt clamp or secured by knotting the tether around the edge of the anchor 400. It should be noted that any type of mechanical mechanism to attach the tether to the anchor may be used.

[0040] Figs 12-15 illustrate yet another embodiment of a clamp according to the present invention. The closed head clamp 420 as illustrated in Figs. 12 and 13, includes a first opening 422 extending through the clamp 420 in a first direction and a second opening 424 extending in a second direction. The first and second direction are generally perpendicular to one another. The first opening 422 is configured to receive an elongate rod 426 and the second opening 424 is configured to receive a tether 428. The clamp 420 is further provided with a fastening element 430 that is used to secure both the rod 426 and the tether 428. In this embodiment, Figs. 12 and 13 also illustrate that the second opening 424 is positioned at a bottom portion of the clamp 420, thus, as the fastening element 430 is tightened, the fastening element 430 contacts the rod 426

which is pushed against the tether 428 thereby securing the tether 428 and rod 426 within the clamp.

[0041] In an alternative embodiment of the closed head clamp as illustrated in Figs. 14 and 15, the closed head clamp 432 includes a first opening 434 and a second opening 436. The first opening 434 and the second opening 436 are configured to be generally transverse to one another. The first opening 434 is dimensioned to receive an elongate rod 438 and the second opening 436 is dimensioned to receive a tether 440. The clamp 432 also includes a fastening element 442, such as a set screw, which when tightened secures and locks the tether 440 and the elongate rod 438 within the clamp 432. In this particular embodiment, the second opening 436 is positioned between the fastening element 442 and the elongate rod 438. When the fastening element 442 is tightened, the fastening element 442 directly contacts the tether 440 which contacts the elongate rod 438 thereby securely locking the tether 440 and the elongate rod 438 within the closed head clamp 432.

[0042] Figs. 16-18 illustrate alternative embodiments of the inventive device. Specifically, Fig. 16 illustrates the use of clamp to attach the tether to the lamina of a vertebra. As illustrated, the tether may encircle the lamina and may be tightened using a belt clamp. The other end of the tether is as shown in the earlier embodiments coupled to a portion of the ilium. Using this mechanism, the deformity of the spine may be corrected by manipulating the tether as well as the positioning of the clamp, as needed.

[0043] Fig. 17 shows a tether that includes a loop which is used to for coupling the tether to the transverse rod to fixate the tether to the transverse rod. Fig. 18 illustrates the coupling of the tether directly to the ilium using another type of tether clamp. It should be noted that in the examples provided of both anchor and clamps, these mechanical devices may be interchangeable.

[0044] It should also be noted that the tether of the present invention may be composed of fabric, polymer, such as PET, or any other biocompatible materials. The tether can be a cable and can be dimensioned to be a wide elastic band which advantageously reduce the risk of damage to tissue lacerations or injury. In some embodiments, the tether can be is between 2 and 900 mm. Also, to ensure that proper correction of deformities, a tensioner can be included as part of the system to make sure that the tether are in proper tension and tightness.

[0045] It will be apparent to those skilled in the art that various modifications and variations can be made in the present invention without departing from the scope or spirit of the invention. Moreover, the improved bone screw assemblies and related methods of use need not feature all of the objects, advantages, features and aspects discussed above. Thus, for example, those skilled in the art will recognize that the invention can be embodied or carried out in a manner that achieves or optimizes one advantage or a group of advantages as taught herein without necessarily achieving other objects or advantages as may be taught or suggested herein. In addition, while a number of variations of the invention have been shown and described in detail, other modifications and methods of use, which are within the scope of this invention, will be readily apparent to those of skill in the art based upon this disclosure. It is contemplated that various combinations or subcombinations of these specific features and aspects of embodiments may be made and still fall within the scope of the invention. Accordingly, it should be understood that various features and aspects of the disclosed embodiments can be combined with or substituted for one another in order to form varying modes of the discussed bone screw assemblies. Thus, it is intended that the present invention cover the modifications and variations of this invention provided that they come within the scope of the appended claims or their equivalents.

Claims

What is claimed is:

1. A spinal system comprising:
 - a clamp for receiving an elongate rod therein, wherein the clamp comprises a first opening for receiving the elongate rod, and a second opening transverse the first opening for receiving a first portion of a tether;
 - a fastener received in the first opening of the clamp;
 - an anchor having a bore hole positioned on a portion of the ilium, the anchor receiving a second portion of the tether,
 - wherein when the set screw is actuated into the first opening, the elongate rod positioned in the first opening and the tether positioned in the second opening are securely locked within the clamp.
2. The system of claim 1, wherein the clamp is positioned on the elongate rod between two bone fasteners.
3. The system of claim 1, wherein the clamp can be moved laterally on the elongate rod prior to tightening of the fastener.
4. The system of claim 1, wherein the fastener is a set screw.
5. The system of claim 1, wherein when the fastener is tightened the fastener applies a force against the elongate rod which applies a force against the tether to securely lock both the tether and the elongate rod within the clamp
6. The system of claim 1, wherein the anchor includes threads for engagement to the ilium.
7. The system of claim 1, wherein the second portion of the tether is passed through the bore hole of the anchor and coupled to a collar.

8. A spinal system comprising:
- a clamp for coupling to an elongate rod and wherein the clamp comprises an opening for receiving a fastener and tether receiving openings configured to receive and secure a first portion of a tether;
 - a fastener received in the opening of the clamp for securing the tether to the elongate rod;
 - an anchor having a bore hole positioned on the ilium, the anchor receiving a second portion of the tether,
 - wherein when the fastener is actuated into the opening, the tether is securely positioned between a portion vertebral column and the ilium.
9. The spinal system of claim 8, wherein the fastener is a set screw.
10. The spinal system of claim 8, wherein the fastener extends through the opening of the clamp through an opening in the elongate rod.
11. The spinal system of claim 8, wherein the tether is looped through the tether receiving openings of the clamp.
12. The spinal system of claim 8, wherein the elongate rod extends from laterally across the spinal column.
13. A spinal system comprising:
- a clamp for coupling to an elongate rod and wherein the clamp comprises a first opening for receiving a fastener and a second opening for receiving a tether;
 - a fastener received in the first opening of the clamp for securing the tether to the elongate rod;
 - an anchor positioned on the ilium, the anchor receiving a second portion of the tether,
 - wherein when the fastener is actuated into the first opening, the tether is securely positioned between a portion vertebral column and the ilium
 - wherein the anchor is configured to secure the second portion of the tether.

14. The spinal system of claim 13, wherein the anchor comprises a first and second opening for receiving a first and second fastener to secure the anchor to the ilium.

15. The spinal system of claim 13, wherein the anchor comprises a third opening for receiving the second portion of the tether.

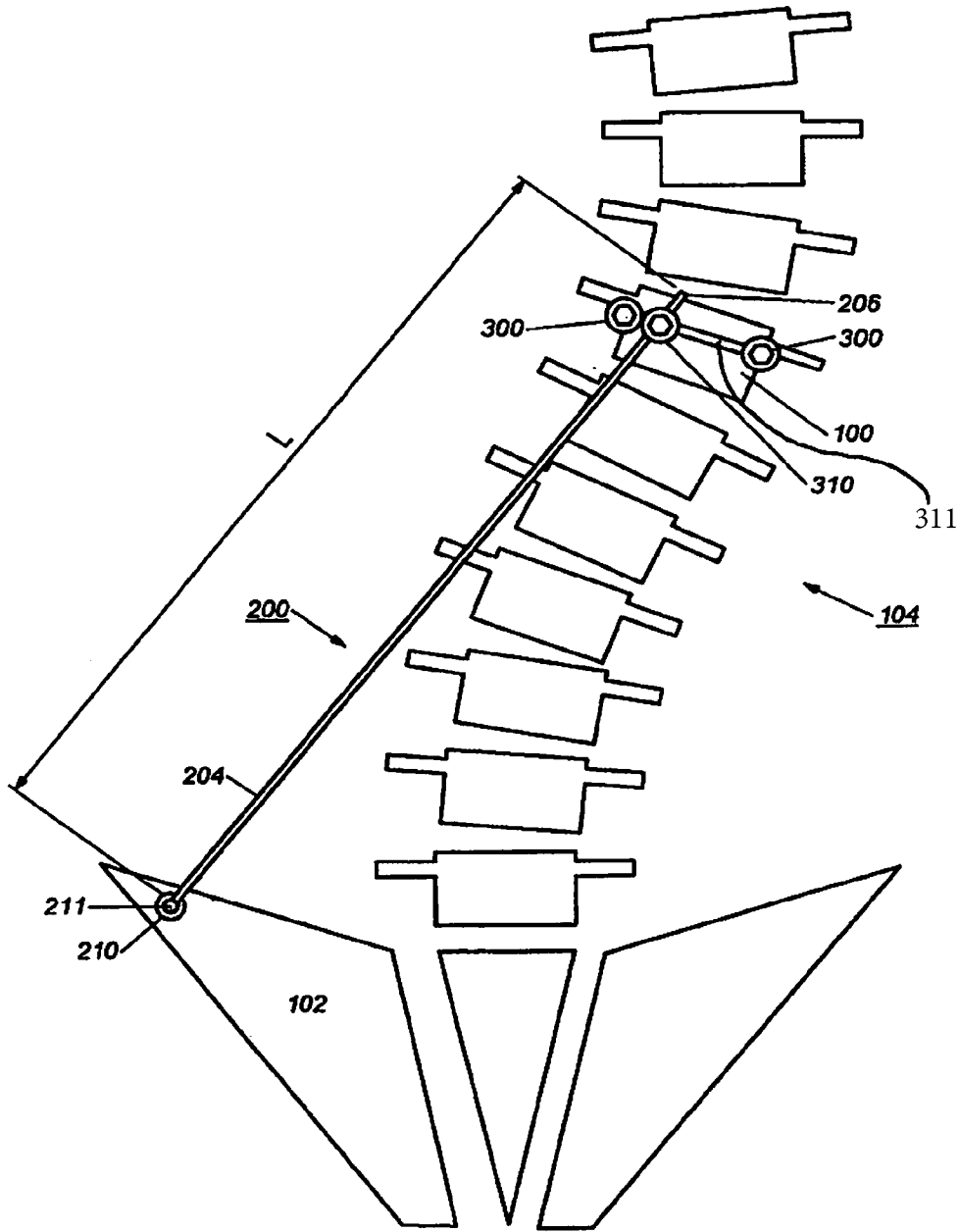

Fig. 1

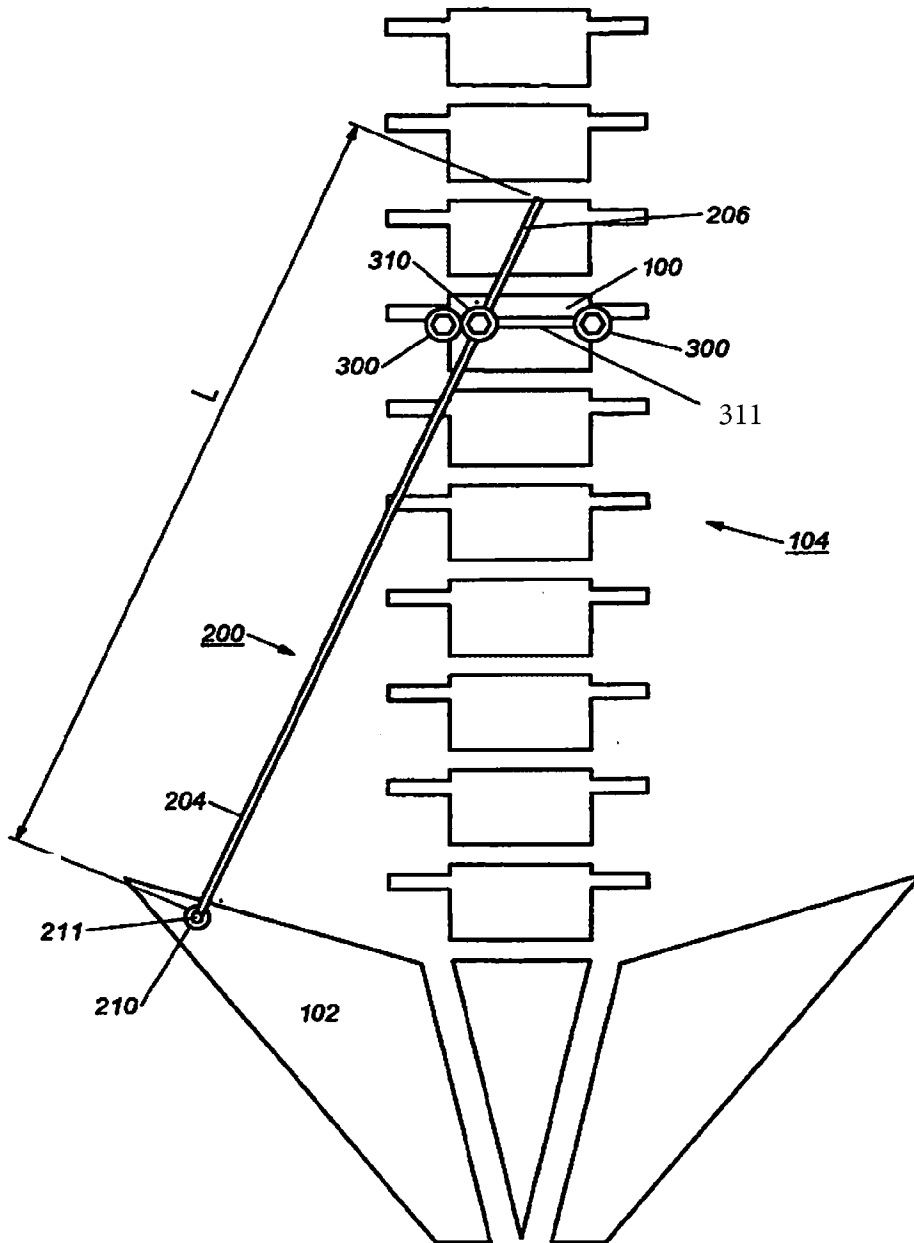

Fig. 2

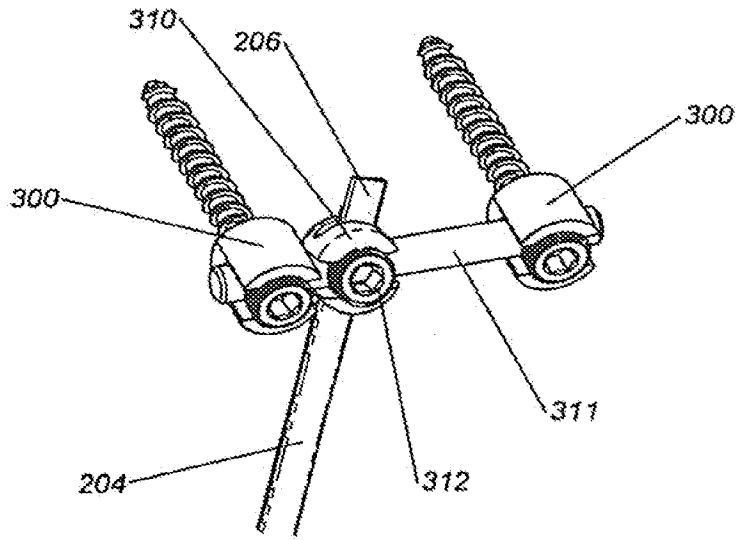

Fig. 3

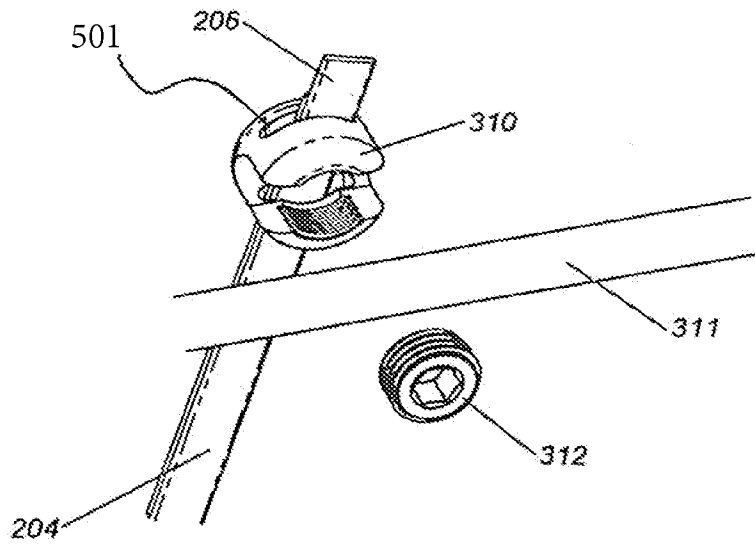

Fig. 4

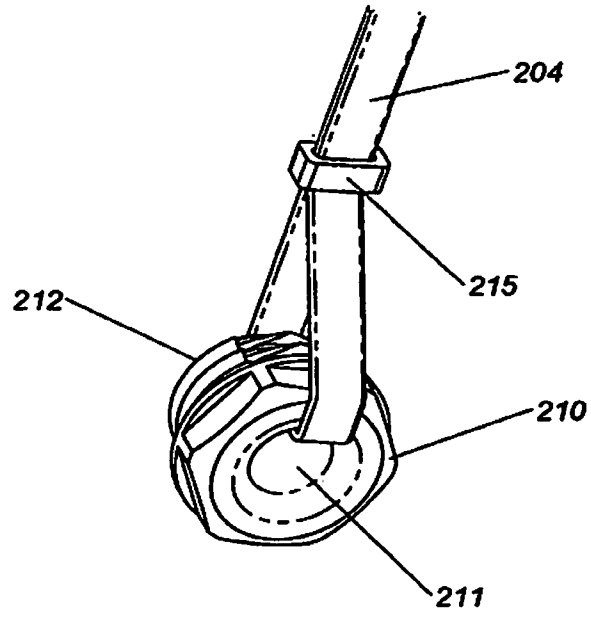

Fig. 5

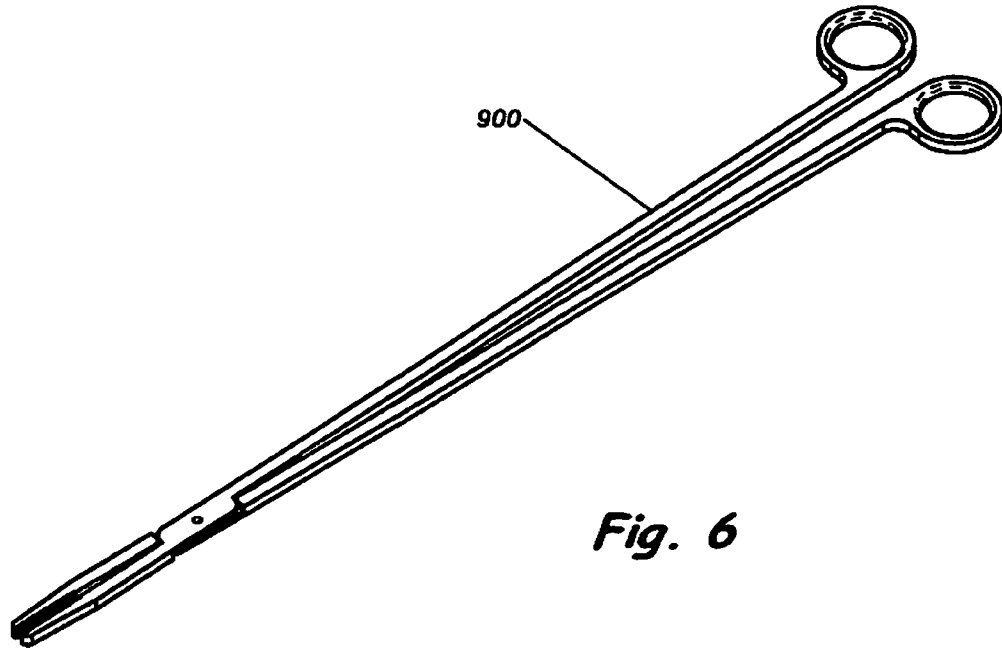

Fig. 6

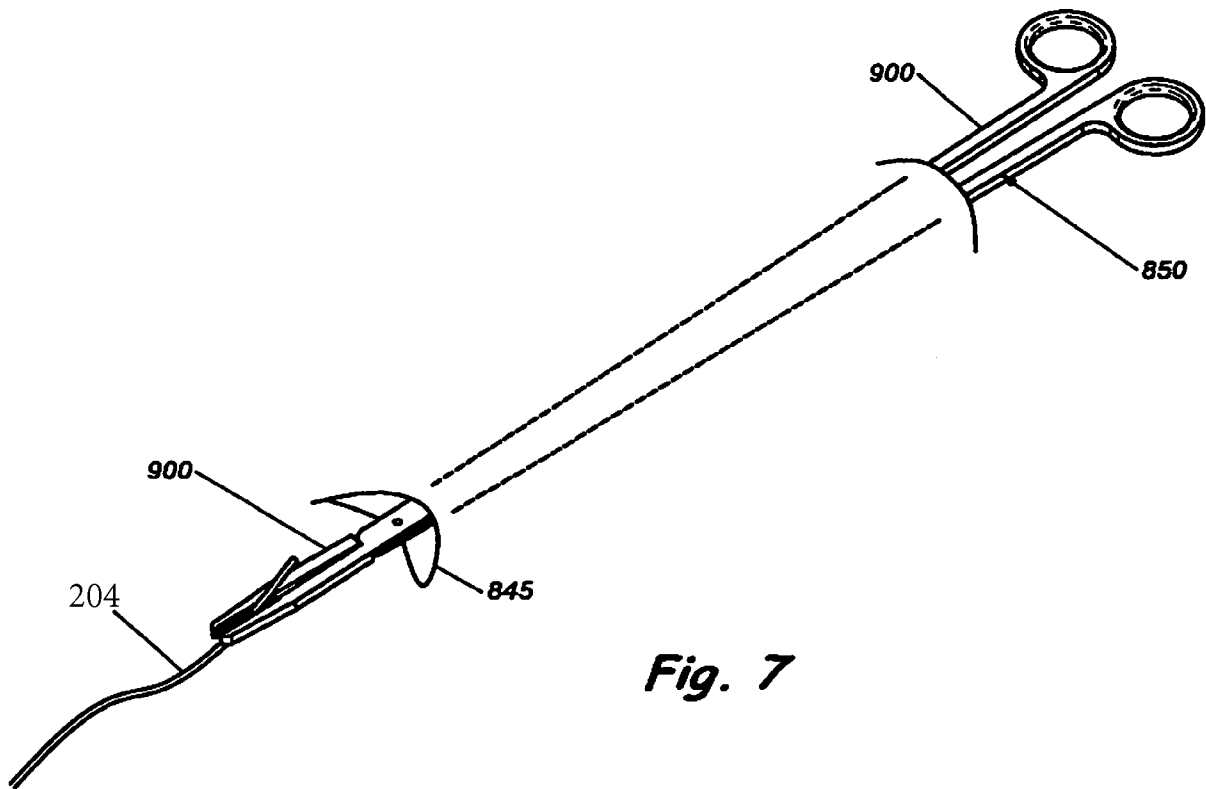

Fig. 7

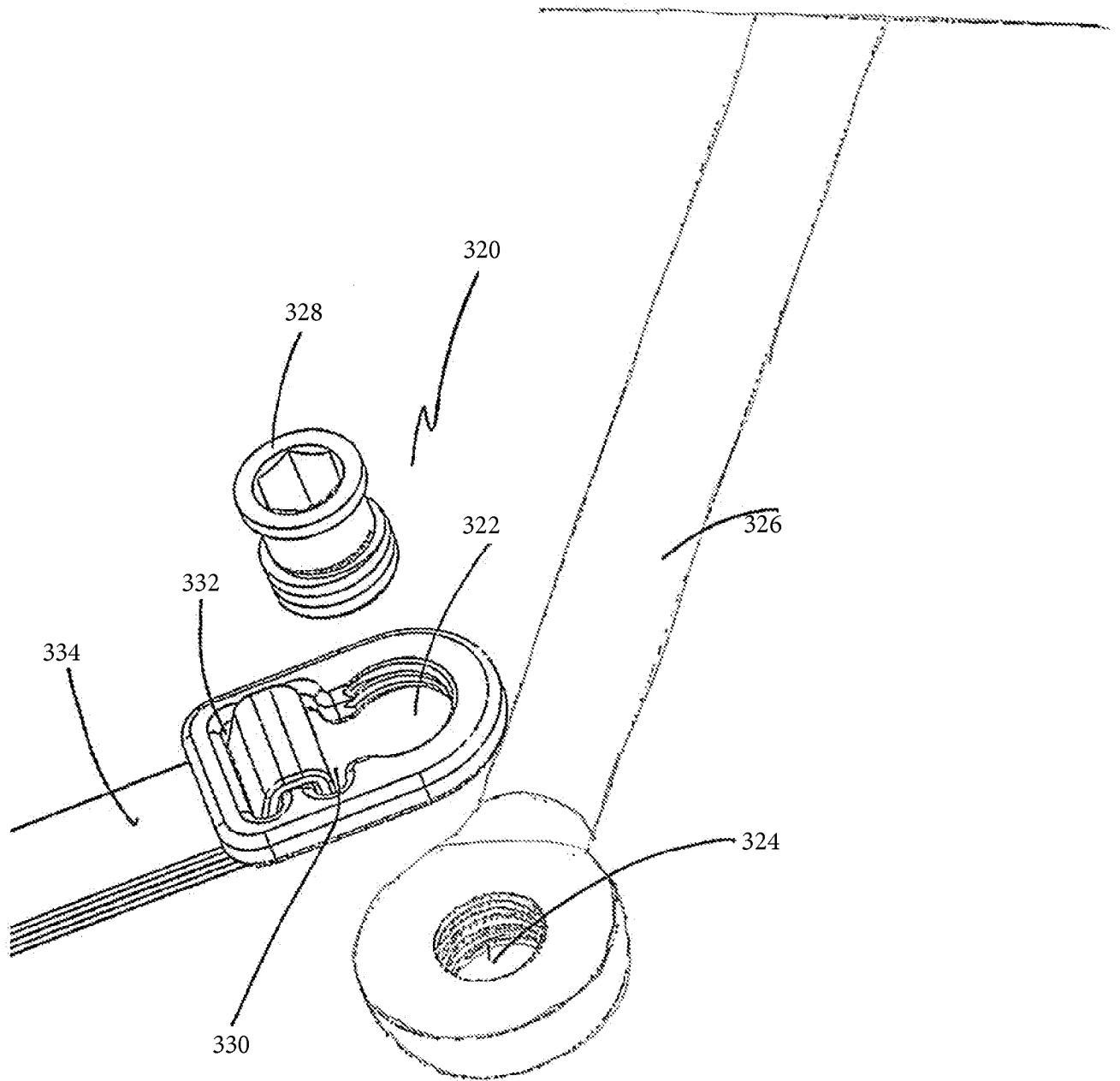

FIG. 8

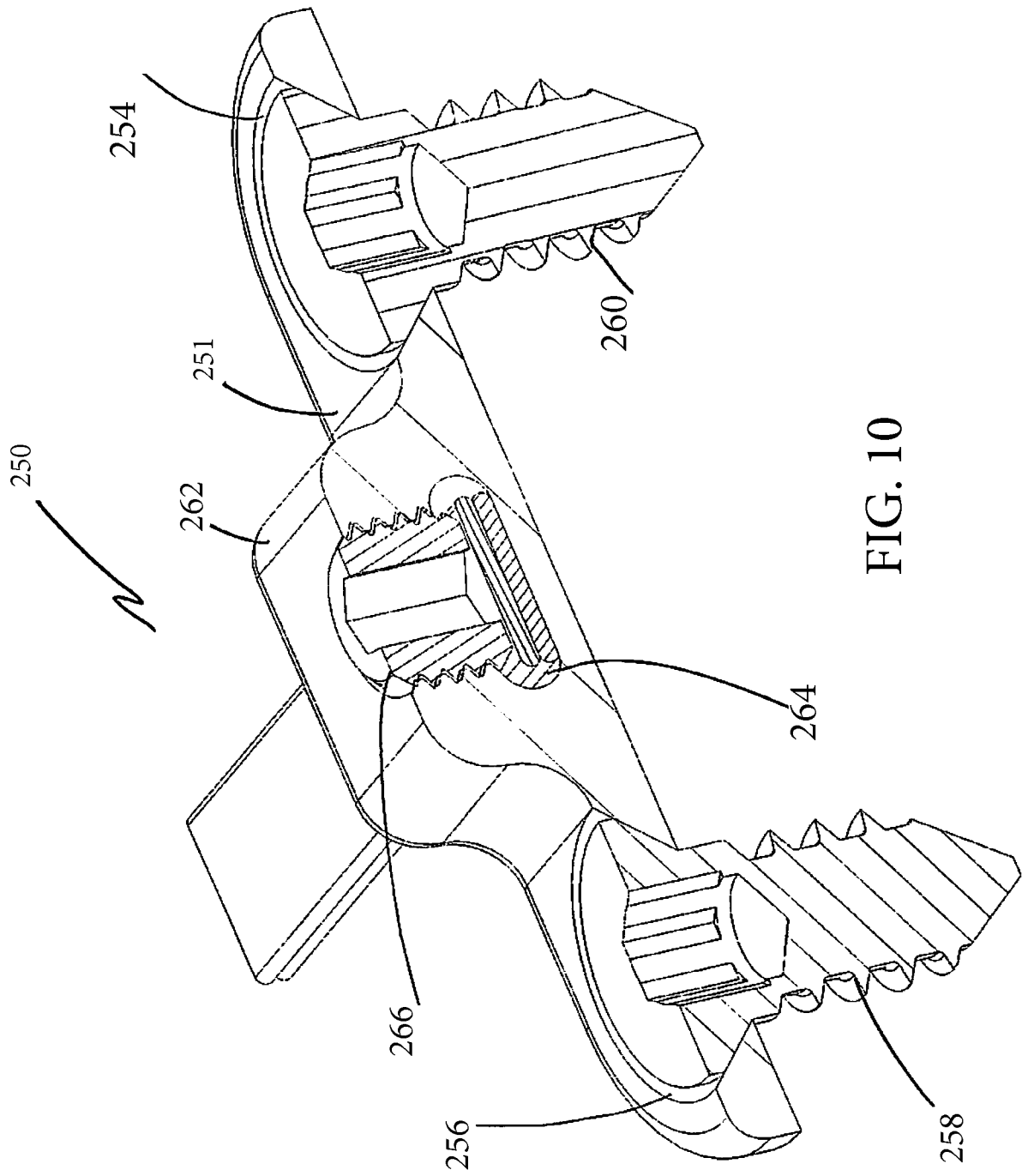

FIG. 10

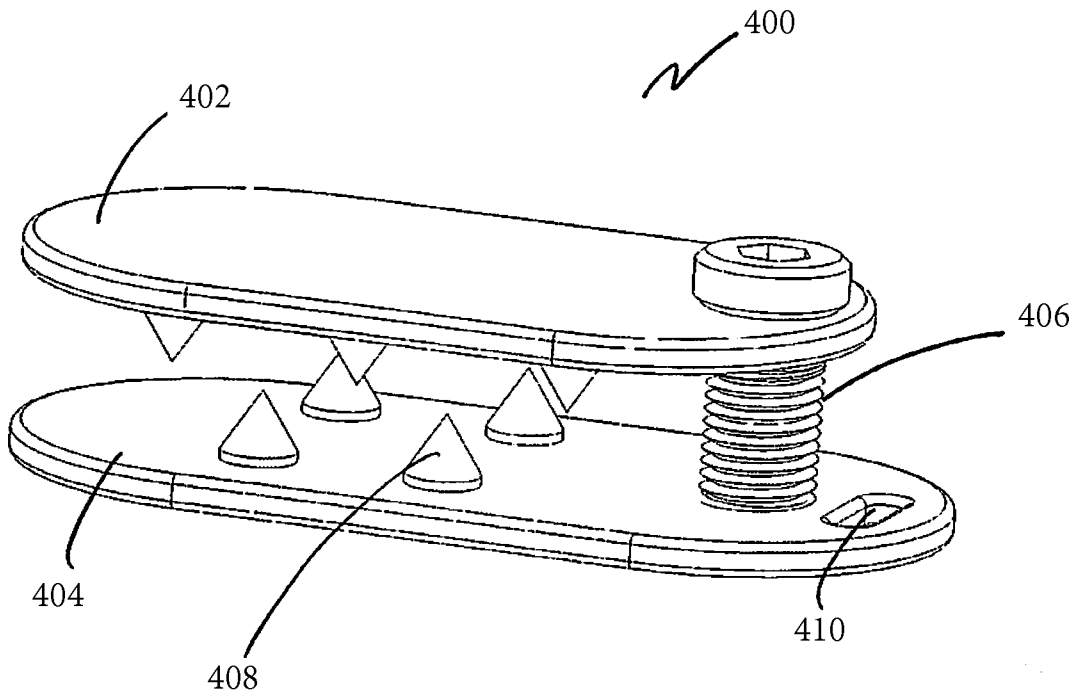

FIG. 11

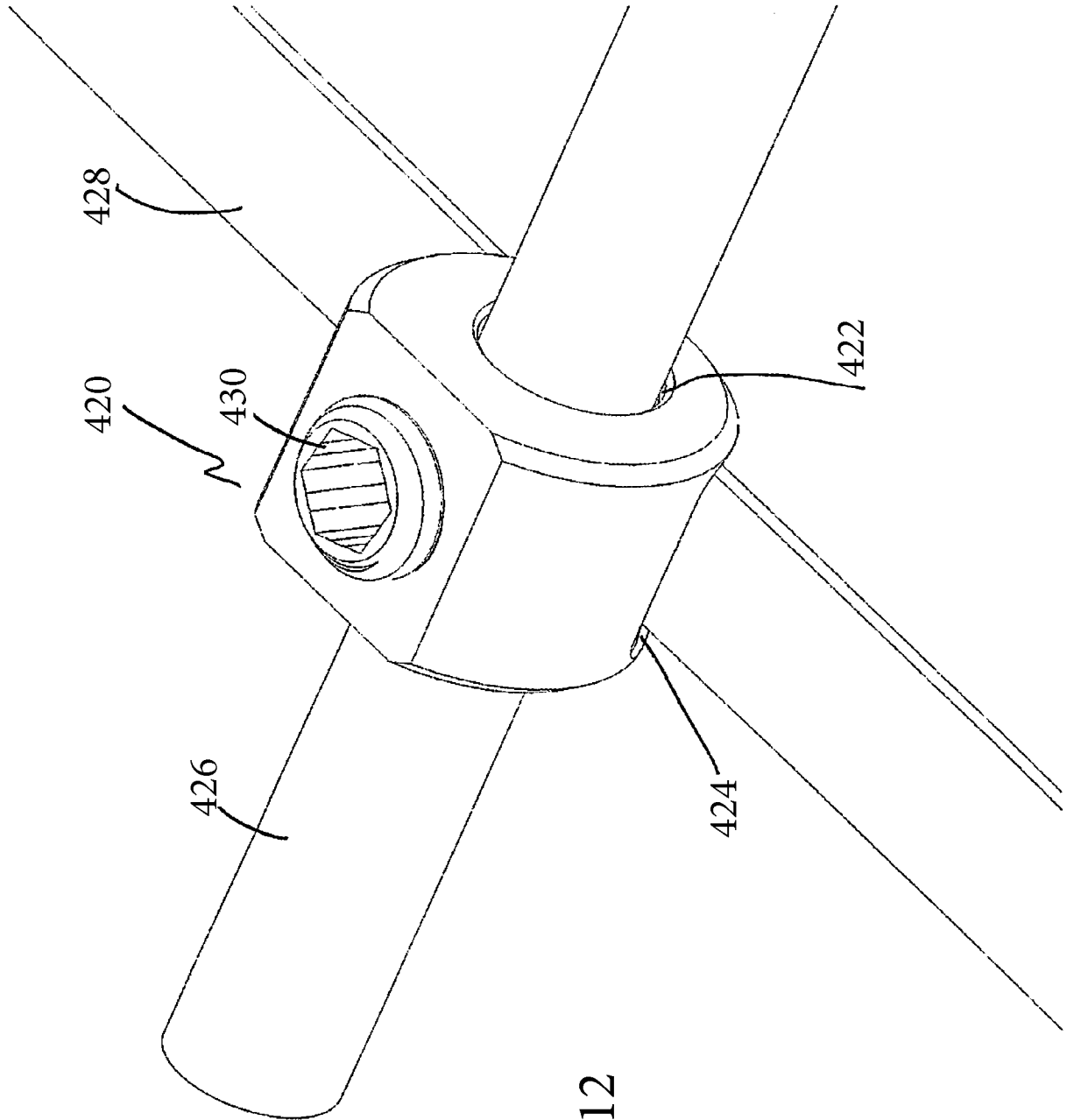

FIG. 12

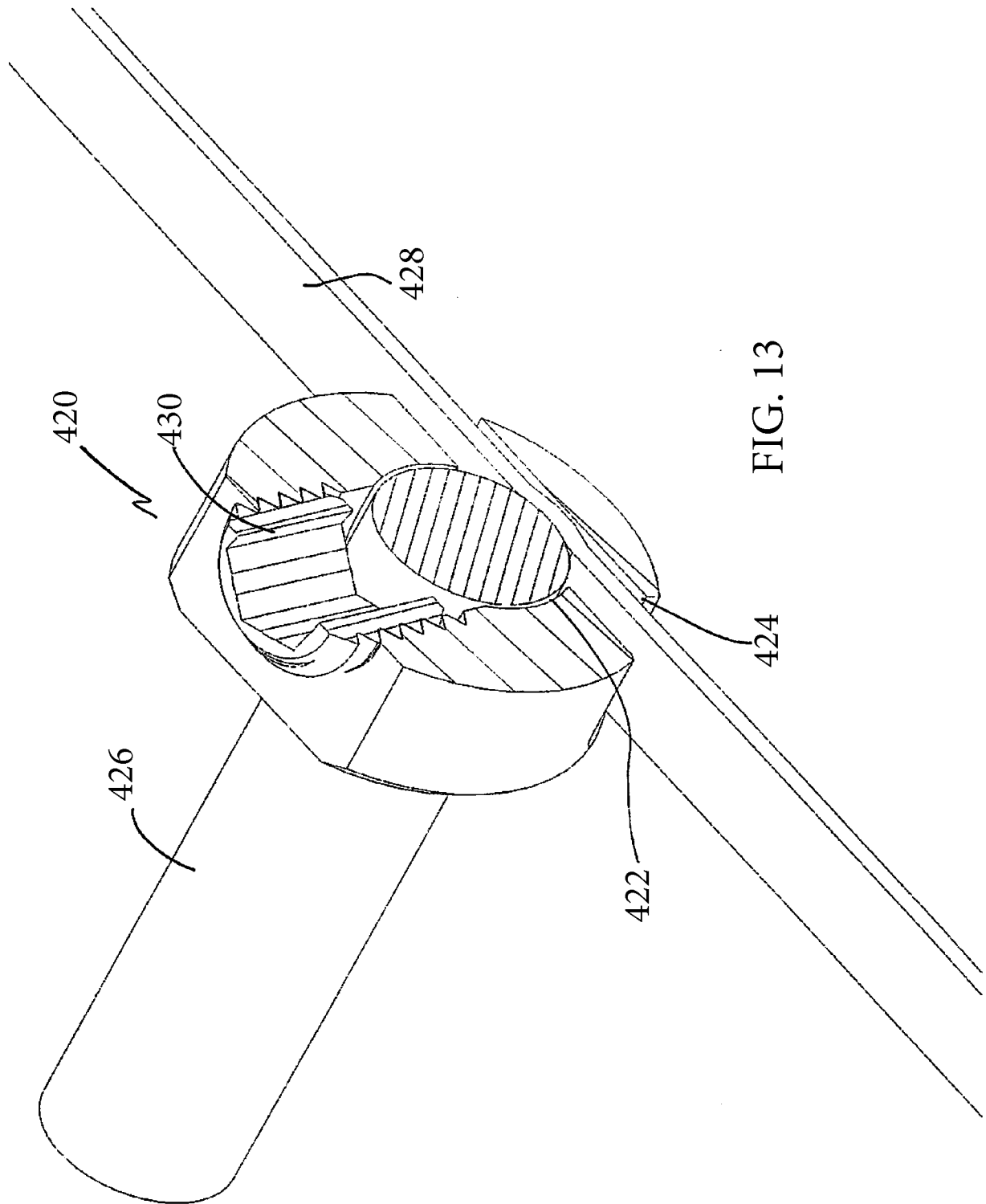

FIG. 13

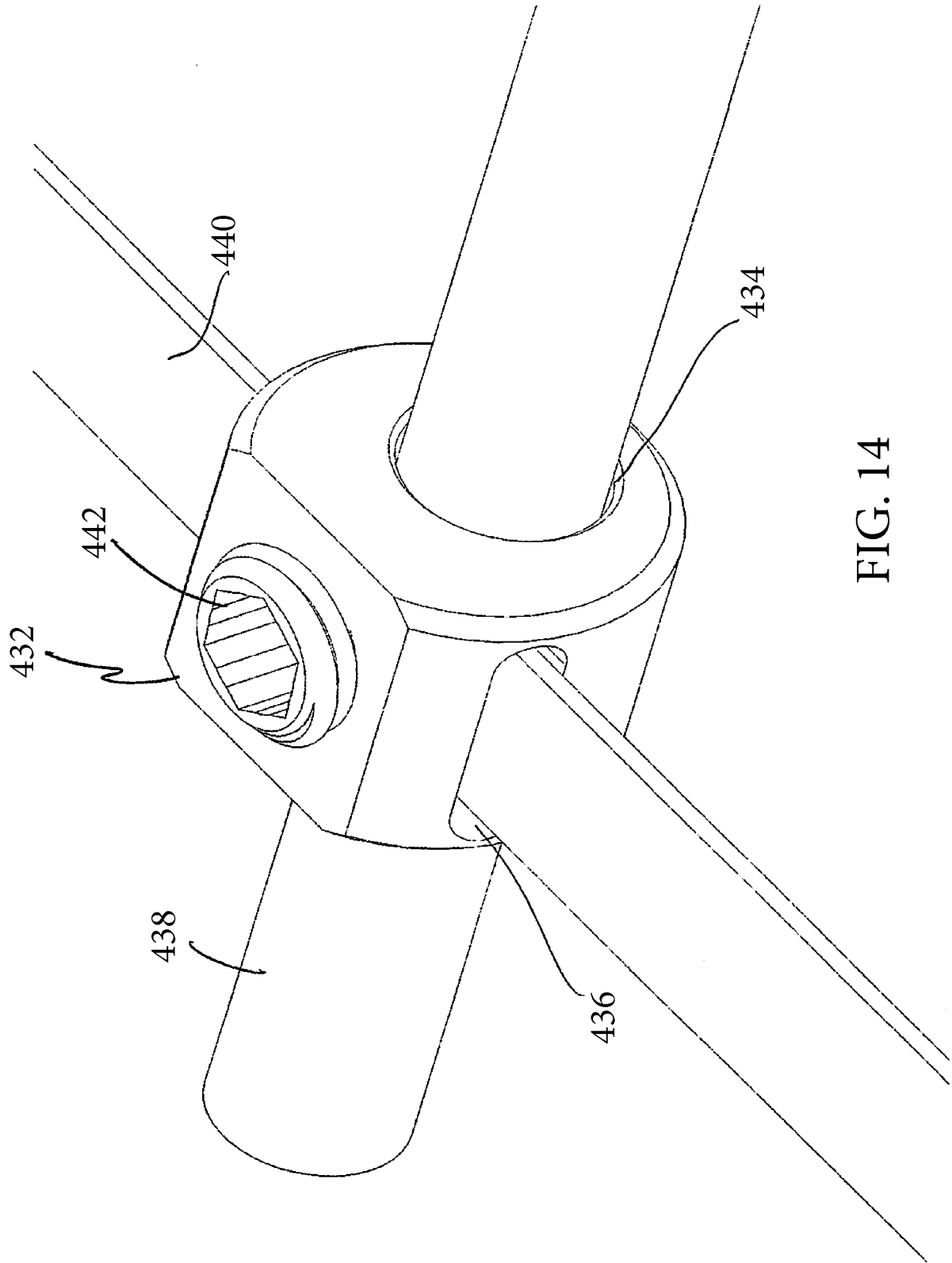

FIG. 14

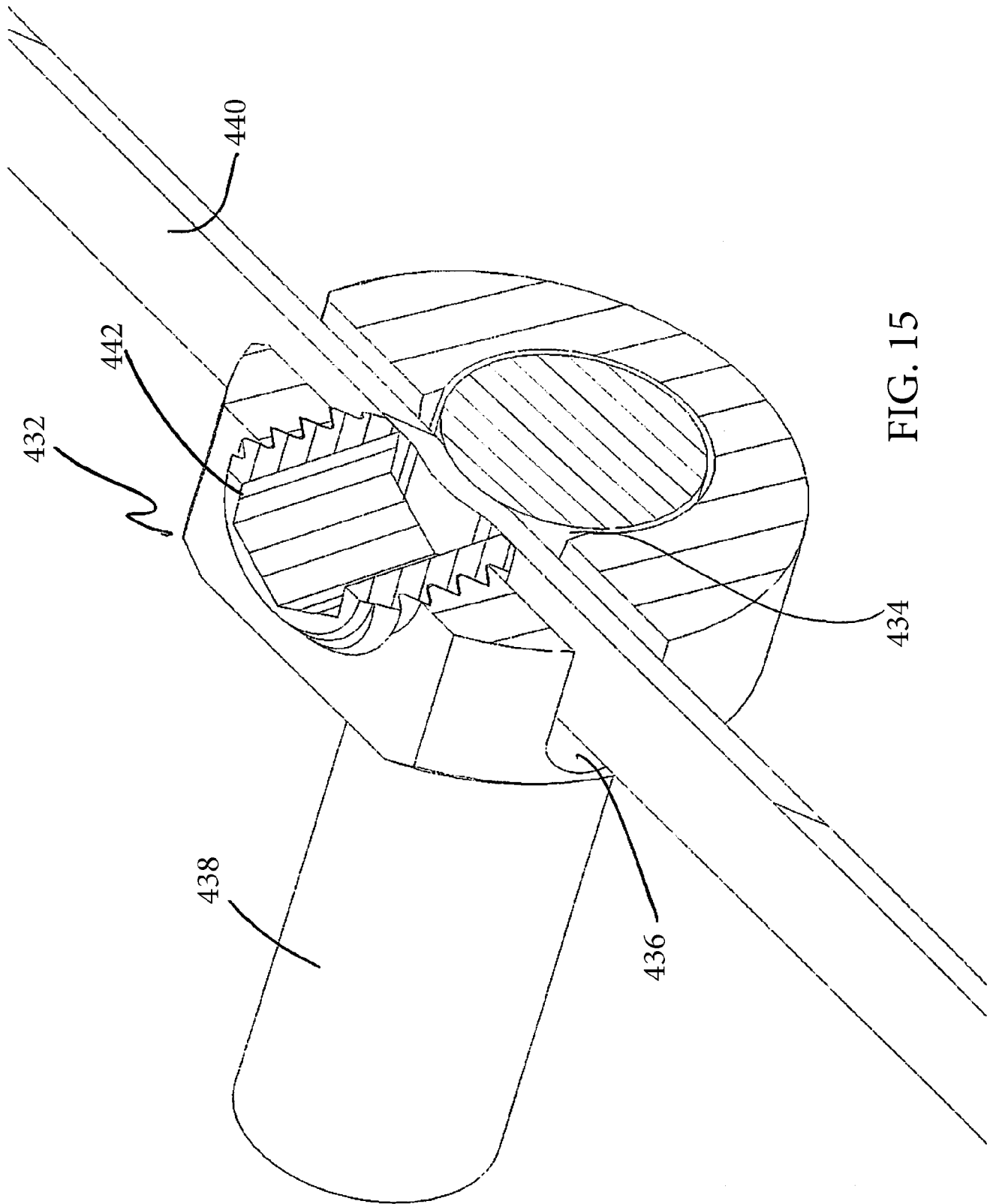

FIG. 15

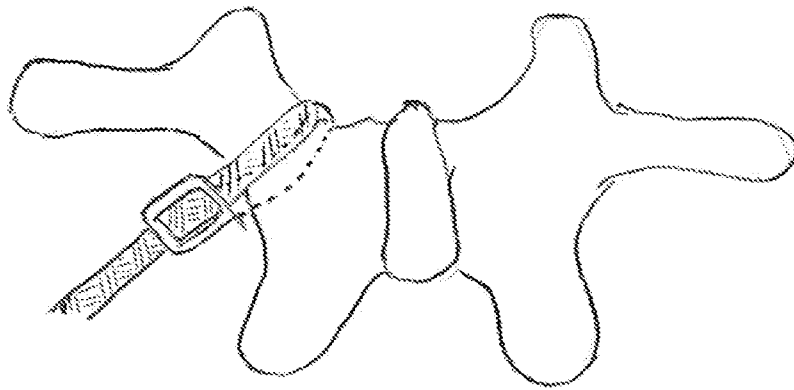

FIG. 16

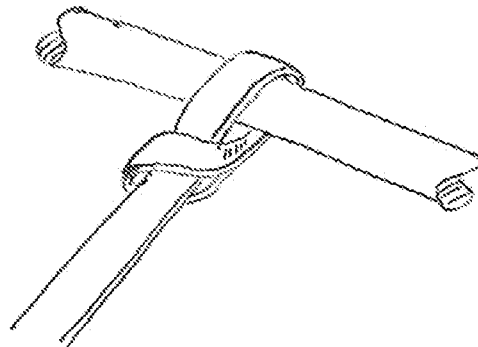

FIG. 17

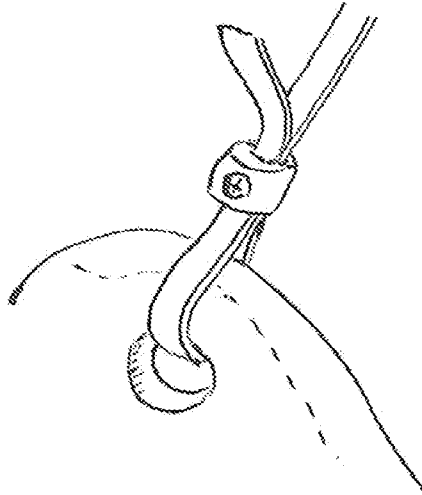

FIG.18

A. CLASSIFICATION OF SUBJECT MATTER**A61F 2/44(2006.01)i, A61B 17/70(2006.01)i, A61F 2/28(2006.01)i**

According to International Patent Classification (IPC) or to both national classification and IPC

B. FIELDS SEARCHED

Minimum documentation searched (classification system followed by classification symbols)

~~A61F~~ 2/44; A61F 2/30; A61B 17/70; A61B 17/08; A61B 17/88; A61F 2/28

Documentation searched other than minimum documentation to the extent that such documents are included in the fields searched

Korean utility models and applications for utility models

Japanese utility models and applications for utility models

Electronic data base consulted during the international search (name of data base and, where practicable, search terms used)

eKOMPASS(KIPO internal) & Keywords: spinal deformity, clamp, tether, fastener, anchor, ilium

C. DOCUMENTS CONSIDERED TO BE RELEVANT

Category*	Citation of document, with indication, where appropriate, of the relevant passages	Relevant to claim No.
A	WO 2012-072413 A1 (ZIMMER SPINE) 07 June 2012 See claims 1-12, 15; page 9, line 11-page 11, line 10; figures 1-11.	1-15
A	US 2009-0281575 A1 (CARLS, T. A. and ALLARD, R. N.) 12 November 2009 See claims 1-7; figures 1-7.	1-15
A	US 2010-0106195 A1 (SERHAN, H. A. et al.) 29 April 2010 See paragraphs [0080]-[0087]; figures 7A-10C.	1-15
A	US 2008-0021456 A1 (GUPTA, M. et al.) 24 January 2008 See the whole document.	1-15
A	EP 2449989 A1 (N SPINE, INC.) 09 May 2012 See the whole document.	1-15

 Further documents are listed in the continuation of Box C. See patent family annex.

* Special categories of cited documents:

"A" document defining the general state of the art which is not considered to be of particular relevance

"E" earlier application or patent but published on or after the international filing date

"L" document which may throw doubts on priority claim(s) or which is cited to establish the publication date of another citation or other special reason (as specified)

"O" document referring to an oral disclosure, use, exhibition or other means

"P" document published prior to the international filing date but later than the priority date claimed

"T" later document published after the international filing date or priority date and not in conflict with the application but cited to understand the principle or theory underlying the invention

"X" document of particular relevance; the claimed invention cannot be considered novel or cannot be considered to involve an inventive step when the document is taken alone

"Y" document of particular relevance; the claimed invention cannot be considered to involve an inventive step when the document is combined with one or more other such documents, such combination being obvious to a person skilled in the art

"&" document member of the same patent family

Date of the actual completion of the international search

24 December 2013 (24.12.2013)

Date of mailing of the international search report

26 December 2013 (26.12.2013)

Name and mailing address of the ISA/KR

Korean Intellectual Property Office
189 Cheongsa-ro, Seo-gu, Daejeon Metropolitan City,
302-701, Republic of Korea

Facsimile No. +82-42-472-7140

Authorized officer

Han, Inho

Telephone No. +82-42-481-3362



INTERNATIONAL SEARCH REPORT

Information on patent family members

International application No.

PCT/US2013/062502

Patent document cited in search report	Publication date	Patent family member(s)	Publication date
WO 2012-072413 A1	07/06/2012	EP 2460482 A1	06/06/2012
US 2009-0281575 A1	12/11/2009	US 8292930 B2	23/10/2012
		WO 2009-137561 A2	12/11/2009
		WO 2009-137561 A3	25/02/2010
US 2010-0106195 A1	29/04/2010	AU 2006-229616 A1	05/10/2006
		AU 2006-229616 B2	02/09/2010
		CA 2602499 A1	05/10/2006
		CN 101146486 B	21/03/2012
		EP 1861024 A1	05/12/2007
		EP 1861024 B1	14/03/2012
		EP 2404563 A1	11/01/2012
		EP 2404563 B1	10/04/2013
		JP 2008-534050 A	28/08/2008
		US 2006-0217713 A1	28/09/2006
		US 2006-0217714 A1	28/09/2006
		US 2006-0217715 A1	28/09/2006
		US 7909826 B2	22/03/2011
		US 8123749 B2	28/02/2012
		US 8273086 B2	25/09/2012
		WO 2006-104538 A1	05/10/2006
US 2008-0021456 A1	24/01/2008	AU 2007-277420 A1	31/01/2008
		CA 2658371 A1	31/01/2008
		EP 2043535 A2	08/04/2009
		WO 2008-013623 A2	31/01/2008
		WO 2008-013623 A3	14/08/2008
EP 2449989 A1	09/05/2012	AU 2004-275735 A1	07/04/2005
		AU 2004-275735 B2	10/12/2009
		AU 2006-220929 A1	14/09/2006
		AU 2008-216286 A1	21/08/2008
		CA 2539923 A1	07/04/2005
		CA 2591277 A1	15/06/2006
		CA 2591848 A1	06/07/2006
		CA 2600672 A1	14/09/2006
		CA 2675782 A1	21/08/2008
		CA 2675931 A1	21/08/2008
		CN 101246410 A	20/08/2008
		CN 101611564 A	23/12/2009
		CN 101632173 A	20/01/2010
		CN 101632173 B	20/07/2011
		CN 101636118 A	27/01/2010
		CN 101636118 B	18/07/2012
		CN 101657810 A	24/02/2010
		CN 101657810 B	25/07/2012
		CN 101912297 A	15/12/2010
		CN 102283704 A	21/12/2011

INTERNATIONAL SEARCH REPORT

Information on patent family members

International application No.

PCT/US2013/062502

Patent document cited in search report	Publication date	Patent family member(s)	Publication date
		CN 102880601 A	16/01/2013
		CN 1882286 A	20/12/2006
		CN 1882286 B	26/05/2010
		EP 1677689 A2	12/07/2006
		EP 1686906 A2	09/08/2006
		EP 1827265 A2	05/09/2007
		EP 1830723 A2	12/09/2007
		EP 1858424 A1	28/11/2007
		EP 2111171 A1	28/10/2009
		EP 2115772 A1	11/11/2009
		EP 2115890 A2	11/11/2009
		EP 2124641 A2	02/12/2009
		EP 2126736 A2	02/12/2009
		JP 2007-506514 A	22/03/2007
		JP 2007-516733 A	28/06/2007
		JP 2008-522748 A	03/07/2008
		JP 2008-525118 A	17/07/2008
		JP 2008-531210 A	14/08/2008
		JP 2010-517708 A	27/05/2010
		JP 2010-518534 A	27/05/2010
		JP 2010-518784 A	27/05/2010
		JP 2011-031057 A	17/02/2011
		JP 2012-110737 A	14/06/2012
		JP 2013-034215 A	14/02/2013
		KR 10-0499558 B1	05/07/2005
		KR 10-0499559 B1	05/07/2005
		KR 10-0550262 B1	08/02/2006
		KR 10-0550263 B1	08/02/2006
		KR 10-0554359 B1	24/02/2006
		KR 10-1096337 B1	20/12/2011
		KR 10-2009-0109585 A	20/10/2009
		KR 10-2009-0119847 A	20/11/2009
		KR 10-2009-0119871 A	20/11/2009
		US 2005-0065515 A1	24/03/2005
		US 2005-0065516 A1	24/03/2005
		US 2005-0124991 A1	09/06/2005
		US 2005-0177157 A1	11/08/2005
		US 2005-0203513 A1	15/09/2005
		US 2005-0203514 A1	15/09/2005
		US 2005-0203517 A1	15/09/2005
		US 2006-0195093 A1	31/08/2006
		US 2007-0055247 A1	08/03/2007
		US 2007-0123871 A1	31/05/2007
		US 2007-0225710 A1	27/09/2007
		US 2007-0276380 A1	29/11/2007
		US 2008-0019889 A1	24/01/2008
		US 2008-0192452 A1	14/08/2008
		US 2008-0193015 A1	14/08/2008
		US 2008-0193608 A1	14/08/2008
		US 2008-0195372 A1	14/08/2008

INTERNATIONAL SEARCH REPORT

Information on patent family members

International application No.

PCT/US2013/062502

Patent document cited in search report	Publication date	Patent family member(s)	Publication date
		US 2008-0195452 A1	14/08/2008
		US 2008-0200202 A1	21/08/2008
		US 2010-0313366 A1	16/12/2010
		US 2011-0096521 A1	28/04/2011
		US 2011-0106167 A1	05/05/2011
		US 2011-0301643 A1	08/12/2011
		US 2012-0209330 A1	16/08/2012
		US 7137985 B2	21/11/2006
		US 7326210 B2	05/02/2008
		US 7763052 B2	27/07/2010
		US 7780794 B2	24/08/2010
		US 7815665 B2	19/10/2010
		US 7983897 B2	19/07/2011
		US 7985302 B2	26/07/2011
		US 7993370 B2	09/08/2011
		US 8028230 B2	27/09/2011
		US 8111524 B2	07/02/2012
		US 8249906 B2	21/08/2012
		WO 2005-030029 A2	07/04/2005
		WO 2005-030029 A3	22/09/2005
		WO 2005-030031 A2	07/04/2005
		WO 2005-030031 A3	12/01/2006
		WO 2006-063107 A2	15/06/2006
		WO 2006-063107 A3	28/12/2006
		WO 2006-071742 A2	06/07/2006
		WO 2006-071742 A3	07/12/2006
		WO 2006-096414 A1	14/09/2006
		WO 2008-100940 A1	21/08/2008
		WO 2008-100941 A2	21/08/2008
		WO 2008-100942 A1	21/08/2008
		WO 2008-100943 A2	21/08/2008
		WO 2008-100944 A1	21/08/2008
		WO 2008-100945 A2	21/08/2008
		WO 2008-100946 A2	21/08/2008
		WO 2008-100947 A2	21/08/2008
		WO 2008-100948 A1	21/08/2008
		WO 2008-100949 A2	21/08/2008
		WO 2008-100949 A3	23/10/2008
		WO 2008-100950 A2	21/08/2008
		WO 2008-100950 A3	03/09/2009
		WO 2008-100951 A2	21/08/2008
		WO 2008-100951 A3	19/03/2009
		WO 2008-100952 A2	21/08/2008
		WO 2008-100953 A1	21/08/2008
		WO 2008-100954 A2	21/08/2008
		WO 2008-100954 A3	24/12/2008