



(43) International Publication Date  
22 November 2012 (22.11.2012)

(51) International Patent Classification:

*B65H 75/28* (2006.01)    *B65H 65/00* (2006.01)  
*B65H 19/00* (2006.01)    *B65H 67/08* (2006.01)  
*B65H 19/28* (2006.01)    *H01F 7/20* (2006.01)

(21) International Application Number:

PCT/CA2011/000587

(22) International Filing Date:

18 May 2011 (18.05.2011)

(25) Filing Language:

English

(26) Publication Language:

English

(71) Applicant (for all designated States except US): **HYDRO-QUÉBEC** [CA/CA]; 75, boul. René-Lévesque Ouest, 22e étage, Montréal, Québec H2Z 1A4 (CA).

(72) Inventors; and

(75) Inventors/Applicants (for US only): **FRANCOEUR, Bruno** [CA/CA]; 971, Galilée, Beloeil, Québec J3G 6M1 (CA). **COUTURE, Pierre** [CA/CA]; 1027, Jean-Bochart, Boucherville, Québec J4B 4A4 (CA).

(74) Agent: **ROBIC**; Centre CDP Capital, 1001 Square Victoria Bloc E 8e étage, Montréal, Québec H2Z 2B7 (CA).

(81) Designated States (unless otherwise indicated, for every

kind of national protection available): AE, AG, AL, AM, AO, AT, AU, AZ, BA, BB, BG, BH, BR, BW, BY, BZ, CA, CH, CL, CN, CO, CR, CU, CZ, DE, DK, DM, DO, DZ, EC, EE, EG, ES, FI, GB, GD, GE, GH, GM, GT, HN, HR, HU, ID, IL, IN, IS, JP, KE, KG, KM, KN, KP, KR, KZ, LA, LC, LK, LR, LS, LT, LU, LY, MA, MD, ME, MG, MK, MN, MW, MX, MY, MZ, NA, NG, NI, NO, NZ, OM, PE, PG, PH, PL, PT, RO, RS, RU, SC, SD, SE, SG, SK, SL, SM, ST, SV, SY, TH, TJ, TM, TN, TR, TT, TZ, UA, UG, US, UZ, VC, VN, ZA, ZM, ZW.

(84) Designated States (unless otherwise indicated, for every

kind of regional protection available): ARIPO (BW, GH, GM, KE, LR, LS, MW, MZ, NA, SD, SL, SZ, TZ, UG, ZM, ZW), Eurasian (AM, AZ, BY, KG, KZ, MD, RU, TJ, TM), European (AL, AT, BE, BG, CH, CY, CZ, DE, DK, EE, ES, FI, FR, GB, GR, HR, HU, IE, IS, IT, LT, LU, LV, MC, MK, MT, NL, NO, PL, PT, RO, RS, SE, SI, SK, SM, TR), OAPI (BF, BJ, CF, CG, CI, CM, GA, GN, GQ, GW, ML, MR, NE, SN, TD, TG).

Published:

— with international search report (Art. 21(3))

(54) Title: FERROMAGNETIC METAL RIBBON TRANSFER APPARATUS AND METHOD

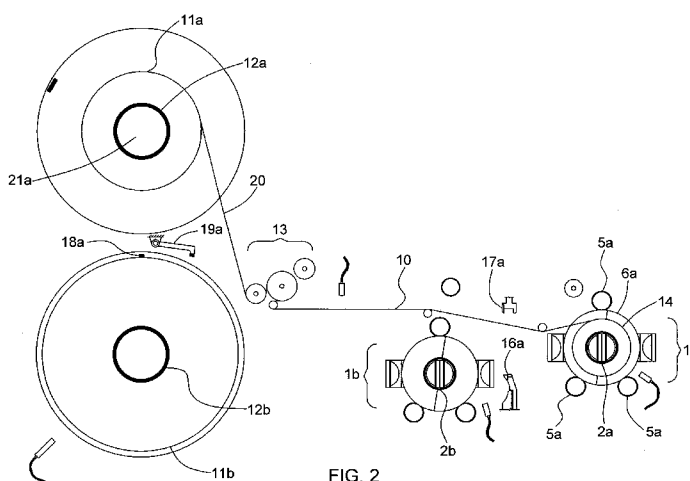

FIG. 2

(57) Abstract: Apparatus, system and methods for transferring of a ferromagnetic metal ribbon from a roll mounted on a mandrel to another mandrel, including a mandrel located around electrical coils of a transformer. The system includes an apparatus for securing a free end of a ribbon roll including a reel onto which the ribbon roll is mounted and a ribbon retention mechanism having retaining elements movable between a retaining position in which the free end of the ribbon roll is secured on the reel and a releasing position in which the free end of the ribbon roll is free from the reel. An apparatus and method for rolling up a cuttable ferromagnetic ribbon on a mandrel are also disclosed. An apparatus and method for rolling up a cuttable ferromagnetic ribbon on a mandrel are also disclosed. An apparatus and method for manipulating and displacing ferromagnetic material along a path are also disclosed.



WO 2012/155232 A1

## **FERROMAGNETIC METAL RIBBON TRANSFER APPARATUS AND METHOD**

### **FIELD OF THE INVENTION**

The present invention relates to the handling of a ferromagnetic metal ribbon. More particularly, it relates to the transferring of a ferromagnetic metal ribbon from a roll mounted on a mandrel to another mandrel. More particularly, it relates to transferring of a ferromagnetic metal ribbon from a roll mounted on a mandrel to another mandrel located around the electrical coils of a transformer.

10

### **BACKGROUND OF THE INVENTION**

Iron-based amorphous alloys are sought for their soft magnetic properties in the making of magnetic cores. They are manufactured by continuous rapid solidification of a stream of molten alloy cast on a moving chilled surface at speeds approaching 100 km per hour to output a very thin and ductile metal ribbon of various widths which can be cut at different lengths. Magnetic cores are then produced either by rolling a continuous ribbon or, by stacking multiple ribbon lengths. However, residual mechanical stresses are introduced into the alloy during casting, and applied stresses are added afterwards by bending or stacking the ribbon. These stresses will impair the magnetic properties and must therefore be removed from the ribbon when it adopts a final configuration into a core or, at least accommodated to a certain extent. Stress removal from the amorphous metal ribbon is generally accomplished by annealing the material in a furnace at an elevated temperature for a predetermined amount of time. Also, the magnetic properties are improved if a magnetic saturation field or a tensile strength is applied along the ribbon longitudinal axis during the furnace annealing treatment. Unfortunately, the furnace annealing treatment embrittles the alloy which becomes impossible to cut and difficult to manipulate. Embrittlement of iron-based amorphous alloys induced by furnace annealing has been a recurring problem for a long time.

20

30

A method for producing a distribution transformer kernel with a ferromagnetic amorphous metal ribbon is disclosed by Allan et al. in US patent 5566443. A transformer kernel in the present document refers to the arrangement in the transformer comprising the electric coils, the core and the elements for supporting them together, without the transformer enclosure and surrounding accessories. In this patent, a number of electric coils are preformed, each having a portion with a shape of a sector of a circle. The preformed coils are then assembled together so that their portions combine to form a circular limb and, in order to construct the magnetic core, a continuous ferromagnetic amorphous metal ribbon is rolled up on a circular hollow mandrel located around the circular limb to produce a circular core. Before being rolled up, the amorphous metal ribbon has been previously furnace annealed under a magnetic saturation field on a second circular mandrel having the same external diameter as for the circular hollow mandrel, thus requiring a transfer of the annealed ribbon between mandrels.

Rolling-up-after-annealing of amorphous metal circular cores, although simple in appearance, remains a difficult task. The fact that the ribbon becomes brittle following the furnace annealing treatment makes it less convenient when it needs to be rolled up again on a second mandrel. Silgailis et al. in US patent 4668309 have demonstrated in Table 2 of the patent that in each attempt to unroll and to roll up again a ferromagnetic amorphous metal ribbon of a furnace annealed circular core weighting around 50 kg at speeds up to 0.3 meter per second, the ribbon broke more than 60 times. Therefore, production of circular core made with rolling-up-after-annealing of an amorphous metal ribbon which has been previously furnace annealed in a roll is impractical due to the embrittlement of the amorphous alloy.

Shorter annealing times at higher annealing temperatures are believed to yield amorphous metal ribbons with greater ductility. However, there is a limit in trying to shorten the annealing time in a furnace due to a limit in heat transfer capacity within

the core. Higher heat transfer capacity becomes possible by heat treating a single forwarded ribbon, under a tensile stress, in-line along a portion of its travelling path as disclosed in US patents 4482402, 4288260, 5069428, and patent application US2008/0196795. Such apparatus are in-line ribbon annealing process. Once annealed, the ribbon is directly rolled-up on a reel mandrel or on a transformer kernel mandrel like the one disclosed in US patent 5566443. Such apparatus would gain in productivity if means were provided at the input to maintain a continuous supply of ribbon and, at the output to ensure continuous production of rolls either on reel mandrels or on transformer kernel mandrels. According to paragraph [0080] in  
10 US patent application US2008/0196795, the output of the disclosed in-line annealing apparatus can comprise first and second winding spindles, so that it is possible, after winding a first core (or reel) over the first spindle, to cut the ribbon and to fit a head part of the ribbon onto the second spindle, in order to carry out the winding of a second core (or reel), without interrupting the manufacturing process. Paragraph [0084] further states that: it can be advantageous to use a magnetic spindle or a spindle with suction in order to immobilize the ribbon start on the spindle. However, the document does not teach nor show how to realize such continuous winding means and, does not include any means at the input for ensuring a continuous  
20 supply of ribbon.

20

### **SUMMARY OF THE INVENTION**

Accordingly, it is an object of the present invention to provide methods and apparatus to overcome at least one drawback of the prior art.

According to the present invention, there is provided an apparatus for securing a free end of a ribbon roll, comprising:

a reel onto which the ribbon roll is mounted; and

a ribbon retention mechanism having retaining elements movable between a retaining position in which the free end of the ribbon roll is secured on the reel and a releasing position in which the free end of the ribbon roll is free from the reel.

Preferably, the reel comprises a mandrel with first and second lateral flanges on opposite sides of said mandrel, the flanges having respective slots for receiving the respective retaining elements and wherein the retaining elements comprise respective rods that are pivotable with the respective first and second flanges, said rods being pivotable between the retaining position in which each rod extends  
10 towards the opposite flange and the releasing position in which each rod is housed within the retaining element slot of its flange.

According to the present invention, there is also a method for rolling up a cuttable ferromagnetic ribbon on a mandrel, comprising the steps of:

- a) supplying a free end of said cuttable ferromagnetic ribbon in proximity of said mandrel;
- b) simultaneously injecting a current by means of a controllable current source into an electromagnet located in said mandrel, to urge said free end onto the mandrel, and rotating said mandrel to roll up said ribbon on said mandrel;
- 20 c) cutting the ferromagnetic ribbon when a predetermined diameter of ferromagnetic ribbon rolled up on the mandrel has been attained.

Preferably, in step b), the electromagnet comprises at least one conductor coil of a transformer kernel.

Preferably, according to another preferred embodiment, in step b), the electromagnet comprises at least one conductor coil mounted on a ferromagnetic yoke.

Preferably, the ferromagnetic yoke is mounted on a shaft and is housed within the mandrel, the ferromagnetic yoke comprising a plurality of annular-shaped slots spaced-apart along the shaft, said slots receiving the at least one conductor coil, the at least one conductor coil being wound such that current injected in the coil circulates in alternating rotational directions between adjacent slots.

According to the present invention, there is also provided an apparatus for rolling up a cuttable ferromagnetic ribbon roll, comprising:

- a mandrel;
- an electromagnet located in said mandrel;
- 10 a controllable motor to rotate the mandrel;
- a controllable current source for injecting a current into the electromagnet;
- a controller for controlling the controllable current source and the controllable motor, to urge a free end of the ribbon onto the mandrel as the mandrel is rotating thereby rolling up the cuttable ferromagnetic ribbon roll on the mandrel; and
- a cutter for cutting the ferromagnetic ribbon when a predetermined diameter of ferromagnetic ribbon rolled up on the mandrel has been attained.

Preferably, the electromagnet comprises at least one conductor coil of a transformer kernel.

- 20 According to the present invention, there is also provided an apparatus for manipulating and displacing ferromagnetic material along a path, comprising:

- an electromagnet;
- a controllable displacement system for displacing the electromagnet along the path;
- a controllable current source for injecting current into said electromagnet; and

a controller for controlling the controllable displacement system and the controllable current source to sequentially capture, displace and release said ferromagnetic material as said electromagnet moves along said path.

According to the present invention, there is also provided a method for manipulating and displacing ferromagnetic material along a path, comprising the steps of:

- a) positioning an electromagnet proximate to the ferromagnetic material;
- b) injecting current into the electromagnet to capture the ferromagnetic material;
- c) displacing the ferromagnetic material captured in step b), along the path;  
and
- d) releasing the ferromagnetic material displaced in step c) by stopping the step of injecting current into the electromagnet.

10

According to the present invention, there is also provided a method for transferring a ferromagnetic ribbon from a ferromagnetic ribbon roll mounted on a first reel to a first mandrel, comprising the steps of:

- a) positioning the first reel at a first unrolling position;
- b) securing a free end of the ribbon roll on the first reel by means of a ribbon retention mechanism having retaining elements movable between a retaining position in which the free end of the ribbon roll is secured on the first reel and a releasing position in which the free end of the ribbon roll is free from the first reel;
- c) positioning an electromagnet proximate to the first reel;
- d) rotating the reel with the free end secured in step b);
- e) after step d), simultaneously triggering the retaining elements from the retaining position to the releasing position to free the free end of the ribbon,

20

and injecting current into the electromagnet to capture the free end of the ribbon;

f) displacing the free end captured in step e) along a path proximate to the first mandrel at a first rolling up position;

g) simultaneously releasing the free end of the ribbon by stopping the step of injecting current in to the electromagnet, injecting a current by means of a controllable current source into a mandrel electromagnet located in said mandrel, to urge said free end onto the mandrel, and rotating said mandrel to roll up said ribbon on said mandrel; and

10 h) cutting the ferromagnetic ribbon when a predetermined diameter of ferromagnetic ribbon rolled up on the mandrel has been attained.

Preferably, the method further comprises the step of:

i) securing a free end of the ferromagnetic ribbon rolled up on the mandrel, obtained after the cutting step h), onto the ribbon roll on the mandrel.

20 Preferably, according to one preferred embodiment, in step i), the step of securing comprises the step of securing the free end of the ribbon roll on the mandrel by means of a second ribbon retention mechanism having retaining elements movable between a retaining position in which the free end of the ribbon roll on the mandrel is secured on the mandrel and a releasing position in which the free end of the ribbon roll on the mandrel is free from the mandrel.

Preferably, according to another preferred embodiment, in step i), the step of securing comprises the step of welding the free end of the ribbon roll on the mandrel onto said ribbon roll on the mandrel.

Preferably, the method further comprises the steps of:

j) between steps g) and h), positioning a second mandrel at a second rolling up position proximate to the path of the ribbon between the first reel and the first mandrel;

10 k) simultaneously with step h), injecting a current by means of a second controllable current source into a second mandrel electromagnet located in said second mandrel, to urge the free end of the ribbon from the first reel cut in step h) onto the second mandrel, and rotating said second mandrel to roll up said ribbon on said second mandrel;

l) removing the first mandrel from the first rolling up position;

m) moving the second mandrel from the second rolling up position to the first rolling up position;

n) cutting the ferromagnetic ribbon when a second predetermined diameter of ferromagnetic ribbon rolled up on the second mandrel positioned in the second position has been attained; and

o) repeating steps j) to n), until the reel positioned in the first unrolling position is empty, to unroll and roll up the ribbon roll on a plurality of mandrels.

Preferably, the method further comprises the steps of:

20 p) providing a second reel having a second ribbon roll at a second unrolling position proximate to the path of the ribbon between the first reel and the first mandrel;

q) securing a free end of the second ribbon roll on the second reel by means of a second ribbon retention mechanism having retaining elements movable between a retaining position in which the free end of the second ribbon roll is

secured on the second reel and a releasing position in which the free end of the second ribbon roll is free from the second reel;

r) rotating the second reel with the free end secured in step q);

s) during the repeating step o) before the first reel becomes empty, triggering the retaining elements of the second reel from the retaining position to the releasing position to free the free end of the second ribbon roll and joining the free end of the second ribbon with the first ribbon of the first reel;

t) after step s), removing the first reel from the first unrolling position, after the first reel is emptied;

10 u) after step t), moving the second reel from the second unrolling position to the first unrolling position; and

v) repeating steps p) to u) continuously, to unroll ribbon rolls continuously from the reels.

Preferably, in step s), the step of joining comprises the steps of:

i) injecting a current by means of a controllable current source into an electromagnet located in an attractor roller, to urge the free end of the second ribbon onto the first ribbon; and

ii) after step i) welding the first and second ribbons together.

20 Preferably, in step ii), the step of welding is carried out by a rotating welder which is mounted on a shaft and comprises a plurality of conductor discs separated by insulating spacer discs, each conductor disc having a narrow tip protruding outwardly from the shaft, the conductor discs being electrically connected such that current polarity alternates between adjacent conductor discs, and the tips of the conductor discs being pressed against the first and second ribbons.

Preferably, the method further comprises the steps of:

AA) positioning an electromagnet of step c) proximate to debris of the ribbon generated upon breakage of the ribbon between the first reel and the first mandrel;

BB) injecting current into the electromagnet of step c) to capture the debris;

CC) displacing the debris captured in step BB) to a disposal location; and

DD) releasing the debris at the disposal location by stopping the step of injecting current into the electromagnet of step c).

10 According to the present invention, there is also provided a system for transferring a ferromagnetic ribbon from a ferromagnetic ribbon roll mounted on a first reel to a first mandrel, comprising:

a first positioning system for positioning the first reel at a first unrolling position;

a first ribbon retention mechanism having retaining elements movable between a retaining position in which a free end of the ribbon roll is secured on the first reel and a releasing position in which the free end of the ribbon roll is free from the first reel;

a first electromagnet;

20 a controllable displacement system for displacing the first electromagnet along a path;

a first controllable current source for injecting current into said first electromagnet;

a first controller for controlling the controllable displacement system and the controllable current source to sequentially capture, displace and release the ribbon as said first electromagnet moves along said path;

a first controllable motor for rotating the first reel;

a first triggering system for triggering the retaining elements from the retaining position to the releasing position to free the free end of the ribbon;

a second controller for controlling the first triggering system, the first controllable current source and the first controllable motor, for simultaneously triggering the retaining elements from the retaining position to the releasing position as the first reel is rotating to free the free end of the ribbon as current is injected into the first electromagnet to capture the free end of the ribbon;

a second positioning system for positioning the first mandrel at a first rolling up position;

a second electromagnet located in said first mandrel;

a second controllable motor to rotate the first mandrel;

10 a second controllable current source for injecting a current into the second electromagnet;

a third controller for controlling the second controllable current source and the second controllable motor, to urge a free end of the ribbon roll as the first mandrel is rotating thereby rolling up the cuttable ferromagnetic ribbon roll on the first mandrel; and

a cutter for cutting the ferromagnetic ribbon when a predetermined diameter of ferromagnetic ribbon rolled up on the first mandrel has been attained.

20 Preferably, the system further comprises a securing apparatus for securing a free end of the ferromagnetic ribbon rolled up on the mandrel, obtained after cutting by the cutter, onto the ribbon roll on the mandrel.

Preferably, according to one preferred embodiment, the securing apparatus comprises a second ribbon retention mechanism having retaining elements movable between a retaining position in which the free end of the ribbon roll on the mandrel is secured on the mandrel and a releasing position in which the free end of the ribbon roll on the mandrel is free from the mandrel.

Preferably, according to another preferred embodiment, the securing apparatus comprises a welder for welding the free end of the ribbon roll on the mandrel onto said ribbon roll on the mandrel.

Preferably, the system further comprises:

- a second positioning system for positioning a second mandrel between a second rolling up position proximate to the path of the ribbon between the first reel and the first mandrel, and the first rolling up position;
- a third electromagnet located in said second mandrel;
- 10 -a third controllable motor to rotate the second mandrel;
- a third controllable current source for injecting a current into the third electromagnet;
- a fourth controller for controlling the third controllable current source and the third controllable motor, to urge a free end of the ribbon roll on the second mandrel as the second mandrel is rotating thereby rolling up the cuttable ferromagnetic ribbon roll on the second mandrel.

Preferably, the system further comprises:

- a third positioning system for positioning a second reel having a second ribbon roll between a second unrolling position proximate to the path of the ribbon between the first reel and the first mandrel, and the first unrolling position;
- 20 -a second ribbon retention mechanism having retaining elements movable between a retaining position in which the free end of the second ribbon roll is secured on the second reel and a releasing position in which the free end of the second ribbon roll is free from the second reel;
- a fourth controllable motor for rotating the second reel;
- a second triggering system for triggering the retaining elements from the retaining position to the releasing position to free the free end of the ribbon;

- a fifth controller for controlling the second triggering system and the fourth controllable motor, for simultaneously triggering the retaining elements from the retaining position to the releasing position as the second reel is rotating to free the free end of the ribbon;
- an attractor roller;
- a fourth electromagnet located in said attractor roller;
- a fifth controllable motor to rotate the attractor roller;
- a fourth controllable current source for injecting current into the fourth electromagnet;
- 10 -a rotating welder for welding the first and second ribbons together; and
- a sixth controller for controlling the fourth controllable current source, the fifth controllable motor, and the rotating welder, to urge the free end of the second ribbon and the first ribbon onto the attractor roller, and weld the first and second ribbons together.

Preferably, the rotating welder is mounted on a shaft and comprises a plurality of conductor discs separated by insulating spacer discs, each conductor disc having a narrow tip protruding outwardly from the shaft, the conductor discs being electrically connected such that current polarity alternates between adjacent conductor discs, and the tips of the conductor discs being pressed against the first and second ribbons.

## **BRIEF DESCRIPTION OF THE DRAWINGS**

Figure 1 is a perspective view of a transformer kernel without a ferromagnetic metal ribbon rolled up on the transformer kernel mandrel.

Figure 2 is a schematic view of an automated system for rolling up a ferromagnetic metal ribbon on transformer kernel mandrels in series according to a preferred embodiment of the present invention.

Figure 3 is a schematic view of automated system for rolling up a ferromagnetic metal ribbon on transformer kernel mandrels in series according to another preferred embodiment of the present invention.

Figure 4 is a schematic view of an automated system for rolling up a ferromagnetic metal ribbon on transformer kernel mandrels in series according to another preferred embodiment of the present invention.

- 10 Figure 5 is a schematic view of an automated system for rolling up a ferromagnetic metal ribbon on reel mandrels in series according to another preferred embodiment of the present invention.

Figure 6 is a schematic view of a control system and controlled elements, according to another preferred embodiment of the present invention.

Figures 7 to 10 are schematic views of sequencing events involved to perform an automatic ribbon splicing when a ribbon is fed from a roll which is running out of ribbon, according to another preferred embodiment of the present invention.

20

Figure 11A to 11C are schematic views showing a securing device mounted on reel flanges and used to secure a free end of a ribbon on a roll according to another preferred embodiment of the present invention.

Figure 12A to 12G include an exploded view, a pair of top and bottom views, another pair of top views and three perspective views respectively showing the detailed construction of a pivoting finger mechanism included in a securing device according to another preferred embodiment of the present invention.

Figure 13 A to 13 C are schematic views showing sequencing events involved in the opening pivoting finger mechanisms, in order to release a free end of a ribbon on a roll, according to another preferred embodiment of the present invention.

Figure 14 is a cut view of a roller comprising an electromagnet for attracting a ferromagnetic metal ribbon according to another preferred embodiment of the present invention.

10 Figure 15 is a cut view of a welding roller pressing a stack of two ribbons against a conductive roller for welding both ribbons according to another preferred embodiment of the present invention.

Figure 16A is a cut view of a transformer kernel with surrounding magnetic field lines induced by a current circulating in the transformer electric coils, according to another preferred embodiment of the present invention.

Figure 16B is a schematic view showing a pair of shear cutting blades according to another preferred embodiment of the present invention.

20 Figure 17 to 20 are schematic views showing sequencing events involved for switching a forwarded ribbon from a completed roll rolled up on a transformer kernel mandrel to another empty rotating transformer kernel mandrel, in order to start a new roll, according to another preferred embodiment of the present invention.

Figure 21 is a schematic view showing switching of a forwarded ribbon from a completed roll rolled up on a reel mandrel to another empty rotating reel mandrel, in order to start a new roll, according to another preferred embodiment of the present invention.

Figure 22 is a schematic view of an automated system for rolling up a ferromagnetic metal ribbon on transformer kernel mandrels in series which is provided with means for starting up the system, according to another preferred embodiment of the present invention.

Figure 23 is a schematic view showing an automated system for rolling up a ferromagnetic metal ribbon on reel mandrels in series which is provided with means for starting up the system.

## 10 PREFERRED EMBODIMENTS OF THE PRESENT INVENTION

Different preferred objects of the present invention will now be presented.

Accordingly, it is an object of the present invention to provide a method and apparatus in which the trailing free end of a ferromagnetic metal ribbon being unrolled from a first reel mandrel running out of material can be spliced with the leading free end a ribbon launched and unrolled from a second filled reel mandrel, in order to supply ribbon without interruption.

- 20 Accordingly, it is another object of the present invention to provide a method and apparatus in which a ferromagnetic metal ribbon being rolled-up in a roll can be cut once the roll is completed and the incoming free end of the cut ribbon will be engaged to start a new roll, in order to produce rolls in series without interrupting the incoming supply of ribbon.

Preferably, the ferromagnetic metal ribbon is rolled-up on reel mandrels in series.

Preferably, the ferromagnetic metal ribbon is rolled-up on core mandrels in series.

Preferably, the ferromagnetic metal ribbon is rolled-up on transformer kernel mandrels in series.

Referring to Figure 1, there is shown a transformer kernel 1 having some similarities with the one disclosed in US patent 5566443. This transformer kernel 1 is provided with a hollow mandrel 2 free to rotate around a central limb formed by electrical coils 3 assembled on a frame 4. The transformer kernel mandrel 2 is rotated by a number of drive rollers 5 urged and distributed against the outer periphery of two flanges 6 mounted at opposite ends of mandrel 2. The coils 3 and frame 4 are held still by means, not shown, in a position to avoid a frictional contact with the rotating mandrel 2. The drive rollers 5 each have one edge flush with the inner wall of the flanges 6. At least one of the drive rollers 5 is mechanically linked to a shaft of a servo motor, not shown. A ferromagnetic ribbon engaged on the transformer kernel mandrel 2 is then rolled-up to form a magnetic core by rotating the mandrel 2 using at least one of the motorized drive rollers 5 on the flanges 6.

Referring to Figure 2, there are shown main parts of an automated system for rolling up a ferromagnetic metal ribbon on transformer kernel mandrels in series. A ribbon 10 supplied from a roll 11a supported on a reel mandrel 12a is passed through a ribbon splicer 13 and is then rolled up on a rotating transformer kernel mandrel 2a to form a roll 14 which will become the core of a transformer kernel 1a. When the roll 14 on the rotating mandrel 2a is completed, the system actuates shear cutting blades 16a and 17a to cut the transferring ribbon 10 and activates a mechanism to wrap the leading free end of the cut ribbon on an empty transformer kernel rotating mandrel 2b, in order to roll up a new core for a transformer kernel 1b. The system also comprises a standby rotating reel mandrel 12b filled with a roll 11b which will take the relay in supplying the ribbon 10 once the reel mandrel 12a runs out of ribbon. The ribbon free end on the outer surface of roll 11b is held against the roll by a securing device 18a mounted on the reel flanges and, at the proper moment, is released by a swinging lever 19a, in order to be launched towards the ribbon splicer

13 where it will be spliced on a trailing portion 20 of the ribbon outgoing from reel mandrel 12a.

In the shown apparatus, the ribbon 10 is transferred at a specific speed and is under a specific tensile stress. The ribbon transfer speed is controlled by setting either rotating speed of reel mandrel 12a via a motorized spindle 21a, or the rotating speed of transformer kernel mandrel 2a via motorized drive rollers 5a urged against the transformer kernel mandrel flanges 6a. The ribbon tensile stress is then adjusted by setting the rotating torque of the mandrel located at the opposite end of the transferring ribbon. Since a filled reel mandrel normally contains enough ribbon to roll up cores for multiple transformer kernels, it therefore has a bigger mass than the cores it produces. In this case, it is preferable to control the ribbon transfer speed by setting the rotating speed of reel mandrel 12a and, to control the ribbon tensile stress by setting the rotating torque of transformer kernel mandrel 2a. However, as the mass of the roll 14 gets bigger on mandrel 2a, it may become difficult to control the tensile stress in the ribbon when the ribbon transfer is achieved between the two large rotating masses.

Referring to Figure 3, a tensioning roller 22a free to move vertically between two guiding rollers is added to pull on the ribbon with a set force. The vertical position of tensioning roller 22a is used to set the rotating speed of mandrel 2a, in order to synchronize the rolling speed with the feeding rate of the ribbon supplied by the roll 11a. The tensile stress is then easily controlled by the set pulling force on roller 22a which has a small mass. With the setup of Figure 3, the unrolling and rolling-up tensile stresses are the same.

Referring now to Figure 4, if different unrolling and rolling-up tensile stresses are required, a second tensioning roller 22b with a position sensor 23b can be added upstream and separated from tensioning roller 22a by a capstan motorized drive roller 24, which is used to drive and set the ribbon transferring speed. The tensioning

roller 22b with the position sensor 23b are then used to set the unrolling tensile stress and the rotating speed of reel mandrel 12a and, the tensioning roller 22a with the position sensor 23a are used by the controller to set the rolling up tensile stress and the rotating speed of transformer kernel mandrel 2a.

In addition to illustrating rolling up cores of transformer kernels in series, Figure 5 also shows a system comprising means for rolling up rolls of ribbon on reel mandrels in series. Such an apparatus can be installed at the output of a ribbon casting process or, at the output of a in-line ribbon annealing process 25. In this system, a transferring ribbon 26 is being rolled up to form a roll 11c on a reel mandrel 12c which also comprises a ribbon securing device 18b. The securing device 18b is engaged by a swinging lever 19b to secure the free end of the trailing ribbon on roll 11c after it has been cut by the shear blades 16b and 17b upon completion of roll 11c. At the same time, the leading end of the cut ribbon is switched onto an empty reel mandrel 12d without interrupting the ribbon transfer. The in-line ribbon annealing process 25 is also continuously supplied with a ribbon unrolled alternately from rolls using the automated splicing system described hereinabove.

Referring now to Figure 6, there is shown a schematic drawing of a control system. A controller 30 which comprises a CPU and a memory bank is connected to peripheral elements via I/O ports, in order to receive information status or to send instructions to the elements. The peripheral elements include electronic amplifiers connected to servo motors to control their rotating torque or speed, each servo motor driving via a shaft a spindle, a roller, a robot arm, a buggy or any motorized rotating device in the automated systems disclosed in the present invention. The peripheral elements further include actuators to be controlled by the controller 30. These actuators are used at different locations in the disclosed automated systems, such as for activating a swinging lever or the cutting blades. Actuators are also used to control the position of: spindles holding the reel mandrels; holding means holding the transformer kernel coils-frames; drive rollers holding the transformer kernel

mandrels; and all other controllable movable parts disclosed in the present invention. The peripheral elements further include velocity, distance, position and photo sensors from which the controller can read their measured parameters or status. Sensors are used in the present invention to measure the state of the process. The peripheral elements further include controllable current sources which are used to control electromagnets and welders in the present invention. The controller 30 is programmed via a user interface 33. The peripheral elements may include auxiliary controllers to perform local tasks. The running control program, loaded in controller 30 memory, is run by the controller 30 CPU to control the operation of the automated systems for rolling up a ferromagnetic metal ribbon on transformer kernel or reel mandrels in series.

Figures 7 to 10 show detailed sequencing events involved in performing automatic ribbon splicing when a ribbon is fed from a roll which is running out of ribbon. Referring first to Figure 7, the roll 11a on the reel mandrel 12a, which is mounted on the motorised spindle 21a, is unrolled at a rotating speed set by the controller 30 using the tensioning roller 22b and the position sensor 23b to supply a ribbon 10 at a given transfer speed  $V$  and tensile stress  $T$ . The unrolled ribbon 10 snakes through the ribbon splicer 13 comprising an attracting roller 35, a conductive roller 36, a welding roller 37 and a guide roller 38. A precise distance sensor 39a, such as a laser distance sensor, is aimed at the outer surface of roll 11a to measure its distance which is then sent to the controller 30 where the roll thickness on the reel mandrel 12a is continuously computed. The reel mandrel 12b filled with the roll 11b is loaded on a motorised spindle 21b and is adjusted on the spindle to align both sides of roll 11b with the sides of roll 11a. A surface velocity sensor 40a, such as a laser surface velocity meter, is aimed at the surface of the transferring ribbon 10 located downstream to the ribbon splicer 13 to continuously monitor the ribbon transferring speed which is then sent to the controller 30. A surface velocity sensor 40b is aimed at the outer surface of roll 11b to continuously monitor its outer surface rotating speed which is also sent to the controller 30. Before the reel mandrel 12a

becomes empty, the reel mandrel 12b is brought into rotation and its rotating speed is set by the controller 30 in order to null the gap computed between the surfaces speeds received from the two velocity sensors 40a and 40b. The swinging lever 19a is located at a predetermined angle  $\theta$  near the outer periphery of roll 11b with reference to a straight line extending from the rotating axis 41 of reel mandrel 12b to the rotating axis 42 of attracting roller 35.

Referring then to Figure 8, the thickness of roll 11a on reel mandrel 12a has reduced to a size where a splicing sequence must now be initiated as determined by the controller 30 using the distance sensor 39a. Therefore, the controller 30 sends an instruction to an actuator linked to the welding roller 37, in order to press the welding roller against the ribbon passing on the conductive roller 36 at point location 43 and, the controller 30 sends an instruction to an actuator linked to the swinging lever 19a, in order to actuate the swinging lever 19a in between two passes of the securing device 18a. The position of the securing device is known to the controller 30 by using for example a photo sensor. When the securing device 18a crosses the swinging lever 19a, it is forced to open by pushing pins mounted on the swinging lever 19a, in order to release the ribbon free end 44 on the roll 11b. By action of the centrifugal force and of the pressure exerted by the stagnant air surrounding the roll's surface, the ribbon free end 44 is peeled off and is catapulted by acquired momentum in a direction tangential with the roll's outer surface from a launching point 45 close the releasing angle  $\theta$ . The angle  $\theta$  is adjusted to align the trajectory of the ribbon leading end 44 with the outer surface of attracting roller 35. At the same instant, the controller 30 sends an instruction to a current source 46 which will inject a current impulse in an electromagnet located within an hollow portion of attracting roller 35, in order to produce a magnetic field which will attract the incoming ferromagnetic metal ribbon leading end 44 to stick over the ribbon trailing portion 20 unrolling from roll 11a, until the ribbon free end 44 gets guided and trapped under the ribbon trailing portion 20 on the conductive roller 36. At this instant, the controller 30 cuts the rotating speed regulation of reel mandrel 12a with the feedback position

sensor 23b and only maintains a low counterclockwise torque on the motorized spindle 21a and, switches the rotating speed regulation feedback of reel mandrel 12b using the motorized spindle 21b from the velocity sensors 40a and 40b to the position sensor 23b.

Referring then to Figure 9, the controller 30 sends an instruction to a current source 47 which will inject a welding current between the welding roller 37 and the conductive roller 36, in order to bind both stacked ribbons. The welding current is maintained until the trailing end of ribbon portion 20 reaches the welding point 43.

10 This occurrence can be anticipated by the controller 30 using a photo detector, not shown, located upstream to the attractive roller 35 and aimed on the ribbon trailing portion 20, or built in the distance sensor 39a, to detect the instant when the end of the ribbon trailing portion 20 will pass. Then, the rotation of reel mandrel 12a is stopped following an instruction sent by the controller 30 to the motorized spindle 21a.

Referring finally to Figure 10, after the splicing is completed, the empty reel mandrel 12a is removed from spindle 21a and the spindle positions are switched. The controller 30 sends instructions to actuators linked to each spindle 21a and 21b. The  
20 spindle 21a position is moved to the left to allow the spindle 21b position to move up while the rotation of reel mandrel 12b is maintained and then, the spindle 21a position is brought down to the place previously occupied by spindle 21b. While the roll 11b is being unrolled, a new reel mandrel filled with a roll of ribbon is loaded on spindle 21a, in order to be prepared for the next splicing sequence. Therefore, a continuous feeding of a ribbon in the present apparatus is provided.

A detailed construction and operation of a ribbon securing device 18a is shown in Figures 11 to 13. Referring to Figures 11A and 11B, detailed portions of a reel mandrel provided with side flanges 50 and containing a ribbon roll 11b are shown.  
30 The ribbon securing device 18a comprises two pivoting finger mechanisms 51

respectively embedded, facing each other, in the outer periphery of the reel flanges 50, for securing or releasing the ribbon free end 44 on the surface of roll 11b. In Figure 11A, two pivoting fingers 52 are closed and are securing the ribbon free end 44. In Figure 11B, the two pivoting fingers 52 are opened and the ribbon free end 44 is released. When the pivoting fingers 52 are opened, they are embedded in the wall of reel flanges 50, in order to clear the way for the ribbon to roll-up on or to unroll from the roll 11b.

Referring now to Figures 12A, a finger 60 covered with resilient material 61 is  
10 perpendicularly linked to the side of a barrel 62. The finger 60 is sufficiently long to provide enough contact for holding the ribbon free end 44 when extending over the roll 11b as shown in Figure 11A. Referring back to Figure 12A, the barrel 62 has a shaft 63 extending on one side and which is provided with a small slot 64 near the tip for receiving a snap ring 65. The shaft 63 will pass through a hole 66 in a supporting frame 67 to extend beyond on the other side, in order to slide-on a coil spring 68 and a compressing washer 69 which will both be held in place by the snap ring 65. The support frame 67 further has two openings 70 on opposite sides of hole 66, with all three holes being aligned in parallel with the edge 71 of the supporting frame 67. Each of the openings 70 is for receiving a lubricated rolling ball 72 to be secured-in  
20 by a plug 73 from the underside of the supporting frame 67. Preferably, each plug 73 has a spherical recess to fit on the rolling ball 72. Also, each of the openings 70 on the top side of the supporting frame 67 is made slightly narrower near the surface so that the rolling ball 72 will bulge out from the surface without escaping. The supporting frame 67 also has holes 74 for inserting securing screws, in order to secure the assembly to the reel flange 50. Referring to Figure 12B, the underside portion of the barrel 62 has four recesses 75 equally distributed around the shaft 63. When the pivoting finger mechanism is assembled, the spring 68 is compressed and pulls the barrel 62 to lean on the bulging rolling balls 72 and thus, providing with the recesses 75 ninety degrees angular stable positions for the barrel 62 on the  
30 supporting frame 67. Referring to Figure 12C and 12D, the barrel 62 has two

perpendicular flat portions 76 and 77 working with an upright wall 79 provided on the supporting frame 67 to limit the pivoting span angle to ninety degrees, and thus providing only two ninety degrees stable angle positions for the barrel: one stable position with the finger 60 extending out perpendicularly from the supporting base edge 71 when set in closed position and, one stable position with the finger 60 aligned on the support base when set in opened position. Going back to Figure 12B, the rotation of the barrel is achieved by pushing on a lever. The top portion of the barrel 62 comprises two wall portions 80 and 81 for providing a lever when a force is perpendicularly applied at a distance  $d$  from the pivoting axis 83 of the barrel. In

10 Figure 12C, when the pivoting finger is opened, a pushing pin 84 moving sideways from left to right and hitting the wall portion 80 will flick the pivoting finger clockwise to a closed position and in Figure 12D, when closed, the same pushing pin 84 moving sideways from right to left and hitting the wall portion 81 will flick the pivoting finger counterclockwise to an opened position. As it can be seen in Figures 12C and 12D, the only part protruding beyond the supporting base edge 71 is the finger 60 when set in a closed position. Preferably, the pushing pin 84 is surrounded with a layer 85 of rubber-like material to soften the impact force when the pin hits the lever.

Figures 12E to 12G show the rotation of the pivoting finger 52 from a perspective

20 view. During rotation, the pivoting finger 52 is subjected to an axial displacement imposed by the bulging balls 72 rolling on the underneath side of the barrel 62 in between recesses 75. While pivoting, the finger initially makes an upward movement with the bulging balls 72 rolling out of the recesses 75, to reach a highest point in Figure 12F and then, the finger moves downwards as the bulging balls 72 are engaging in the next corresponding recesses 75. This upward movement of the barrel 62 allows the finger 60 to clear the roll 11b outer edge before going downwards, in order to make contact with the roll 11b surface. The finger 60 can have permanent magnet properties to force the ribbon end to peel off from the roll

30 deform on contact with the surface of roll 11b under the pressuring force exerted by

the compressed spring 68. Preferably, the pivoting finger remains at a higher distance from the supporting frame 67 when set in an open position as shown in Figure 12E.

Going back to Figures 11A and 11B, the upright wall 86 of the supporting frame 67 is profiled to match with the outer circular edge of the reel flange 50. The ribbon is rolled up until the roll 11b increasing diameter becomes large enough for allowing the closing of the pivoting fingers 52, in order to apply enough pressure on the roll with the fingers to retain the ribbon free end 44. Referring also to Figure 11C, each  
10 flange 50 has a notch 87 on the inside edge to clear a passage for lowering the pushing pins 84 between two passes of the pivoting fingers while the reel is rotating, in order to flick the levers on both barrels at the next pass, after which the pins 84 are quickly pulled up. In Figure 11A, the reel has to rotate clockwise to open the closed pivoting fingers 52 with the pushing pins 84. In Figure 11B, the reel has to rotate counterclockwise to close the opened pivoting fingers 52 with the pushing pins 84.

Figures 13A to 13C show sequencing events for releasing the ribbon free end 44 from the roll 11b. In Figure 13A, the reel is rotating clockwise with the pivoting  
20 fingers 52 closed. The two pushing pins 84 are mounted on the swinging lever 19a which also comprises a pivoting shaft 88. The swinging lever 19a is swung by the actuator, not shown, around the axis 89 of the pivoting shaft 88 to engage the pushing pins 84 in the notches 87, in order to collide with the incoming pivoting fingers 52. Next in Figure 13B, the pushing pins 84 are pushing against the pivoting fingers 52 to release the ribbon free end 44 from roll 11b. Next in Figure 13C, the pivoting fingers 52 are completely opened and the ribbon free end 44 is released and catapulted. The events shown can be sequenced backwards from Figures 13C to 13A with the reel rotating counterclockwise to explain how the trailing end 44 of a ribbon being rolled-up on roll 11b can be secured just after the incoming ribbon has  
30 been cut. The location of the cut on the ribbon is determined by the controller 30 in

relation to the position of the pivoting fingers during the rotation of the reel to ensure that the fingers will pinch the ribbon free end 44 as shown in Figure 13A.

Figure 14 shows an axial cut view of the attracting roller 35. It comprises a non-ferromagnetic cylinder 90 mounted with bearings 91 and flanges 92 on a shaft 93 to form a roller. Inside the hollow portion of the formed roller, a ferromagnetic yoke 94 is mounted on the shaft 93 and is provided with teeth 95 forming a series of discs separated by slots 96 and protruding outwardly towards the underneath surface of cylinder 90 and being separated from said surface by a small gap 97. Each slot  
10 comprises several turns of a conductor coiled around the shaft axis to form a conductive coil 98. All the conductive coils 98 are electrically interconnected, preferably in series, via passageways in the yoke (not shown) and linked to a pair of conductor leads 99 exiting outside of the roller through an opening 100 located in the shaft 93. The electrical interconnections between coils 98 are arranged so that when a current is injected via the conductive leads 99, a total amount of amp-turns will circulate in alternating direction from slot to slot as shown by the series of dot and cross marks. This will create an electromagnet having a series of magnetic poles at the end of each tooth which alternate between south and north from tooth to tooth. Magnetic field leakage lines 101 produced by the poles will extend outwardly from  
20 the roller surface between adjacent poles. A ferromagnetic ribbon 102 approaching the roller in parallel with its rotating axis will intercept the magnetic field leakage lines 101 and will be attracted by a magnetic force to stick on the cylinder 90 surface. The magnetic attracting force exerted on the ribbon will be proportional to the current intensity injected in the conductor leads 99.

Referring now to Figure 15, there is shown the basic construction of the conductive roller 36 and welding roller 37 used for bounding two stacked metal ribbons 105 together while passing over the conductive roller 36. The conductive roller 36 comprises a cylinder 106 preferably made of copper and having a given thickness.  
30 This copper cylinder 106 is mounted with bearings 107 on a shaft 108 via two side

flanges 109 to allow its rotation. The outer periphery of the cylinder 106 guides and supports the two stacked metal ribbons 105. The rotating welding roller 37 comprises a series of stacked copper discs 110 separated by insulating spacer discs 111. The group of stacked discs 110 and 111 are squeezed between two insulating flanges 112 each supported on a shaft 113 through bearings 114 to allow the rotation of the stacked discs. Each copper disc 110 has a narrow peripheral tip 115 protruding outwardly from the roller. When the welding roller 37 is pressed against the stacked ribbons 105 on roller 36, the copper discs 110 make a series of spaced narrow contacts 116 distributed along the width of the stacked ribbons. A weld is then created between the two ribbons by forcing a current to flow between the copper discs 110 via the stacked ribbons and the copper cylinder 106. Preferably, the welding current flows between adjacent discs 110 which are alternating in electrical polarity. The current is supplied to the discs through wires and via sliding contacts, not shown, provided on the shaft and connected to an external electrical current source controlled by the controller 30.

Referring now to Figure 16A, the transformer kernel 1 with its empty mandrel 2 is shown from a radial cut view. When a current pulse is injected in at least one of the electric coils of the transformer by an electrical current source 120, induced magnetic field lines 121 are looping around the transformer kernel mandrel 2 when no magnetic core is present.

Referring to Figure 16B, two shear cutting blades 16a and 17a are shown, each mounted on a respective supporting member 122 and 123. The supporting members 122 and 123 can be actuated vertically by actuators on guiding rails, not shown, which are mounted in parallel with a reference plane 124 so that the two shear cutting blades 16a and 17a can closely meet with a very small separating gap. Means, not shown, are provided on one of the blades to change its horizontal position, in order to perform a precise adjustment of the gap. The whole arrangement 125 of cutting blades can be moved with actuators, not shown, to bring

them near the rotating mandrel 2 when needed. In the present invention, the ribbon is preferably cut while moving. A shear cut is performed by first positioning blade 16a close to the underneath surface of the moving ribbon and then, by actuating blade 17a at a sufficient speed, in order to limit the tensioning stress pulse created in the moving ribbon during the cut.

Figure 17 to 20 show the sequencing events involved for switching a forwarded ribbon from a completed roll 14 rolled up on the mandrel 2a of the transformer kernel 1a to the empty rotating mandrel 2b of the standby transformer kernel 1b, in order to start a new roll. Referring first to Figure 17, a ferromagnetic metal ribbon 10 forwarded at a given speed  $V$  and at a tensile stress  $T$  from a supply source is being rolled up on the rotating mandrel 2a. The rotating speed of mandrel 2a is set by the controller 30 using the motorized drive rollers 5a according to the position sensor 23a linked to the tensioning roller 22a. A precise distance sensor 39b, such as a laser distance sensor, is aimed at the outer surface of roll 14 to measure and transmit to the controller 30 the amount of accumulating ribbon on mandrel 2a. Meanwhile, the transformer kernel 1b having the empty mandrel 2d is installed upstream to the rolling-up location. A surface velocity sensor 40c, such as laser surface velocitometer, is aimed at the surface of ribbon 10 and continuously transmits the ribbon transferring speed to the controller 30. A surface velocity sensor 40d is aimed at the surface of mandrel 2b and also continuously transmits the surface rotating speed of mandrel 2b to the controller 30. Using both velocity sensors, the mandrel 2b is brought into rotation by the controller 30 using drive rollers 5b and its rotating speed is set to null the gap computed between the surfaces speeds read from the two velocity sensors 40c and 40d.

Referring then to Figure 18, the controller 30 sends an instruction to an actuator linked to an urging roller 126a. The urging roller 126a is urged on the transferring ribbon 10 against the surface of the rotating mandrel 2b. Due to some potential inaccuracy in the sensors 40c and 40d, there can be a small difference of surface

speed between the ribbon 10 and the mandrel 2b. Therefore, a torque limit is imposed on the drive rollers 5b at a value set barely above the torque level necessary to work against the friction of all rotating parts when the rotating mandrel 2b is idling. Once the ribbon 10 is pressed against the mandrel 2b, the rotation of mandrel 2b becomes belt-driven by the ribbon and its surface rotating speed will match the ribbon forwarded speed. Then, the shear cutting blades 16a and 17a are brought just past the separating point 128 where the transferring ribbon leaves the surface of mandrel 2b. The blade 16a is raised between mandrel 2b and the left portion of the coils-frame arrangement 129 and is positioned right underneath the surface of the ribbon 10 and, the blade 17a is brought over the surface of the ribbon in alignment with blade 16a. Meanwhile, the controller 30 sends an instruction to an actuator linked to a welding roller 127, such as the one shown in Figure 14, in order to press the welding roller 127 against the outer surface of roll 14. The welding roller 127 could also be replaced by a dispenser of a frangible adhesive tape.

Referring then to Figure 19, as soon as the targeted amount of ribbon on mandrel 2a is reached as detected via the distance sensor 39b, the controller 30 activates the actuators of the blades 17a to cut the ribbon and, a high current impulse is injected into at least one of the electric coils of the transformer kernel 1b using the current source 130 also controlled by the controller 30. Meanwhile, a vacuum is quickly created in the cavity 131 delimited by the mandrel 2b, the ribbon 10, both flanges 6a and the wall portion 132 of the supporting member 122 by injecting a jet of compressed air clinging over a Coanda profile 133 from a nozzle 134 embedded in the supporting member 122 at the lower portion of the cavity 131. The air is supplied to the nozzle 134 by an actuated valve controlled by the controller 30. The top of the supporting member 122 may be covered with a Teflon-like block 135 to reduce friction when the ribbon is pulled down by the vacuum. As the cutting blades 16a and 17a cannot be wider than the ribbon, because they would then contact with the rotating flanges 6a, a small portion of the ribbon extending beyond the edges of the blades may be left uncut. Therefore, the supporting member 123 can be provided

with a hammer head 136 which will hit the ribbon portion at the immediate right location of the block 135 to produce a sudden pulling force on the ribbon trailing end to break the remaining uncut edges. Once the cut is performed, the torque limit imposed on the drive rollers 5b is removed and, the feedback input used by the controller 30 to control the rotating speed of mandrel 2b is immediately switched from the sensors 40c and 40d to the position sensor 23a. Meanwhile, the region of higher air pressure located above the leading end 137 of the cut ribbon will instantly push it down against the surface of mandrel 2b before it passes in front of nozzle 134, at which moment the jet of air will have been already cut off by the controller 30 via the actuated valve. Then, the generated closed loops of magnetic field lines, as shown in Figure 16A, will produce an attracting force on the ribbon leading end to hold the ribbon end against the surface of mandrel 2b until it gets trapped under the second building layer after which, the current impulse generated by the current source 130 may be turned off by the controller 30. Meanwhile, the last set rotating speed on mandrel 2a is maintained by the controller 30 while the controller 30 sends an instruction to a current source 138 which will inject a current into the welding roller 127 to weld the last ribbon layer on roll 14 before the arrival of the incoming trailing end after which the welder roller 127 is pulled away and the rotating mandrel 2a is brought to a halt. Then, the completed transformer kernel 1a is removed.

20

Referring finally to Figure 20, the urging roller 126a, the guide roller 139 and the cutting blades 16a and 17a are pulled away from the transformer kernel 1b with actuators controlled by the controller 30 and, the transformer kernel 1b and corresponding coils-frame supporting means and drive rollers 5b are slowly moved towards the right by actuators controlled by the controller 30, while the ribbon 10 is being rolled up on the mandrel 2b. The transformer kernel 1b will switch positions with the supporting means and drive rollers 5a that were previously supporting the transformer kernel 1a and which are also provided with actuators. Once the positions are switched, the system is then ready to receive a new transformer kernel with an empty mandrel. The new transformer kernel will wait in standby until a next switching

30

sequence is needed and thereby, maintaining a continuous production of rolled up cores on transformer kernel mandrels in series.

The method for continuous production of rolled up cores on transformer kernel mandrels can also be applied for rolling up rolls of ribbon on reel mandrels. Referring to Figure 21, there is shown a setup where a ferromagnetic ribbon 26 is being wound on a reel mandrel 12c. The setup comprises: an urging roller 126b; a pair of shear cutting blades 16b and 17b; the distance sensor 39b; the pair of surface velocity sensors 40c and 40d; and the tensioning roller 22a with the position sensor 23a, all performing similar functions as their corresponding elements described and shown in Figure 17 to 20 and with the sequencing events being merely identical but, with the following differences: Firstly, the attraction of the leading end of the cut ribbon on the reel mandrel 12d is achieved by injecting a high current impulse in an electromagnet similar to the one shown in Figure 13 which is located in an hollow portion of the spindle 21d. The current impulse is injected by a current source 140 controlled by the controller 30. Usage of a jet of air to create a vacuum under the ribbon, although it could be used, is not necessary in this case as the magnetic pulling force is sufficient. Secondly, once the ribbon is cut, its trailing end is secured on roll 11c using the securing device 18b provided on the flanges 50 of the reel mandrel 12d according to the reverse operating sequence of events shown in Figure 13A to 13C. The pivoting fingers of the securing device 18b are in an opened position waiting to be closed over the trailing end of the incoming ribbon when they will both make a first pass to location point 141 where a swinging lever 19b holding pushing pins is swung to flick the pivoting fingers. Also, the ordering command to cut the ribbon is sent by the controller 30 at the moment the securing device 18b passes at an angular point  $\beta$  in advance from location point 141, in order to have the securing device 18b aligned with the ribbon trailing end on the roll 11c. Preferably, an urging roller 142 is temporally pressed against the roll 11c near the location point 141 with an actuator controlled by the controller 30, in order to hold the ribbon against the roll 11c until the pivoting fingers are closed.

Figures 22 and 23 show an apparatus comprising an arm for seizing and guiding a ribbon end, in order to setup the ribbon transferring system and, for removing ribbon debris stuck in the ribbon transferring system following a ribbon break, in order to cleanup the system. In Figure 22, the apparatus comprises a rail 145 for supporting a small motorized buggy 146 which can move horizontally. The small buggy also comprises an actuator to vertically displace an arm 147 which holds an electromagnet head 148 from one extremity. The electromagnet head 148, the vertical actuator and the motorised buggy are all controlled by the controller 30.

10 Other means such as a multi-axis robot arm could be employed to hold and move the electromagnet head. To setup the ribbon transferring system, the electromagnet head 148 is energised and brought near the swinging lever 19a over the ribbon roll 11b having its ribbon free end secured on the roll by the securing device 18a. The reel mandrel 12b is slowly rotated until the securing device 18a gets opened by the swinging lever 19a to release the ribbon free end which is then seized by the energized electromagnet head 148. Then, all rollers, around which the ribbon must snake around, are moved by actuators controlled by the controller 30 to provide a straight opened passageway for unrolling and guiding the ribbon leading end by moving the electromagnet head 148 to the right, in order to reach the transformer

20 kernel mandrel 2a, or a reel mandrel 12c as shown in Figure 23. The rollers shown are used as an example and therefore, any arrangement of rollers in a ribbon transferring system can be considered. The ribbon leading end is then released on the transformer kernel mandrel 2a (or reel mandrel 12c) while a current is injected in at least one of the electrical coils of the transformer kernel 1a (or in the electromagnet located in the spindle 21c) using a current source 150 controlled by the controller 30. The injected current will produce a magnetic force attract and wrap the ribbon around the mandrel 2a (or reel mandrel 12c). The transformer kernel mandrel 2a (or reel mandrel 12c) is then slowly rotated a few turns to trap the ribbon free end in the second build layer in the forming roll. Finally, all rollers are moved

30 back to their operating position and the transferring operation can be started.

The same apparatus can be used for resetting the system if a sudden ribbon break occurs during its transfer. Therefore, all rollers and spindles in the system can be provided with means to instantaneously halt their rotation at the moment the ribbon breaks. A ribbon break can be detected by using photo detectors located along the path of the ribbon and connected to the controller 30 or, by detecting a sudden change in the torque or rotating speed of one of the motorized spindles or drive rollers. Quickly halting all rotating parts will prevent the ribbon from rolling-up on free wheeling rollers. Following the break and after all rotating parts are halted, the rollers are moved to open the passageway. The ribbon portion hanging down from roll 11b is cut using cutting means, not shown, provided on the arm 147 or near roll 11b. Starting from the cut tail, the debris of ribbon stuck in the rollers are picked up by the electromagnet head 148 while moving up to the far right where the picked up ribbon debris are then dropped in a recycling basket 149. Preferably, the transformer kernel 1a (or reel mandrel 12c) is removed and replaced with one having an empty mandrel and, the removed transformer kernel (or reel mandrel) is sent for inspection where it will be refurbished or recycled. Meanwhile, the electromagnet head 148 is brought back near the roll 11b to seize the ribbon free end and the setup procedure as described hereinabove is redone.

20

Although preferred embodiments of the present invention have been described in detailed herein and illustrated in the accompanying drawings, it is to be understood that the invention is not limited to these precise embodiments and that various changes and modifications may be effected therein without departing from the scope of the present invention.

## WHAT IS CLAIMED:

1. An apparatus for securing a free end of a ribbon roll, comprising:  
a reel onto which the ribbon roll is mounted; and  
a ribbon retention mechanism having retaining elements movable between a retaining position in which the free end of the ribbon roll is secured on the reel and a releasing position in which the free end of the ribbon roll is free from the reel.
2. The apparatus according to claim 1, wherein the reel comprises a mandrel with first and second lateral flanges on opposite sides of said mandrel, the flanges having respective slots for receiving the respective retaining elements and wherein the retaining elements comprise respective rods that are pivotable with the respective first and second flanges, said rods being pivotable between the retaining position in which each rod extends towards the opposite flange and the releasing position in which each rod is housed within the retaining element slot of its flange.
3. A method for rolling up a cuttable ferromagnetic ribbon on a mandrel, comprising the steps of:
  - a) supplying a free end of said cuttable ferromagnetic ribbon in proximity of said mandrel;
  - b) simultaneously injecting a current by means of a controllable current source into an electromagnet located in said mandrel, to urge said free end onto the mandrel, and rotating said mandrel to roll up said ribbon on said mandrel;
  - c) cutting the ferromagnetic ribbon when a predetermined diameter of ferromagnetic ribbon rolled up on the mandrel has been attained.
4. The method according to claim 3, wherein in step b), the electromagnet comprises at least one conductor coil of a transformer kernel.

5. The method according to claim 3, wherein in step b), the electromagnet comprises at least one conductor coil mounted on a ferromagnetic yoke.
6. The method according to claim 5, wherein in step b), the ferromagnetic yoke is mounted on a shaft and is housed within the mandrel, the ferromagnetic yoke comprising a plurality of annular-shaped slots spaced-apart along the shaft, said slots receiving the at least one conductor coil, the at least one conductor coil being wound such that current injected in the coil circulates in alternating rotational directions between adjacent slots.
7. An apparatus for rolling up a cuttable ferromagnetic ribbon roll, comprising:
- 10 a mandrel;  
an electromagnet located in said mandrel;  
a controllable motor to rotate the mandrel;  
a controllable current source for injecting a current into the electromagnet;  
a controller for controlling the controllable current source and the controllable motor, to urge a free end of the ribbon onto the mandrel as the mandrel is rotating thereby rolling up the cuttable ferromagnetic ribbon roll on the mandrel; and  
a cutter for cutting the ferromagnetic ribbon when a predetermined diameter of ferromagnetic ribbon rolled up on the mandrel has been attained.
- 20 8. The apparatus according to claim 7, wherein the electromagnet comprises at least one conductor coil of a transformer kernel.
9. The apparatus according to claim 7, wherein the electromagnet comprises at least one conductor coil mounted on a ferromagnetic yoke.
10. The apparatus according to claim 9, wherein the ferromagnetic yoke is mounted on a shaft and is housed within the mandrel, the ferromagnetic yoke

comprising a plurality of annular-shaped slots spaced-apart along the shaft, said slots receiving the at least one conductor coil, the at least one conductor coil being wound such that current injected in the coil circulates in alternating rotational directions between adjacent slots.

11. An apparatus for manipulating and displacing ferromagnetic material along a path, comprising:

an electromagnet;

a controllable displacement system for displacing the electromagnet along the path;

10 a controllable current source for injecting current into said electromagnet; and  
a controller for controlling the controllable displacement system and the controllable current source to sequentially capture, displace and release said ferromagnetic material as said electromagnet moves along said path.

12. A method for manipulating and displacing ferromagnetic material along a path, comprising the steps of:

a) positioning an electromagnet proximate to the ferromagnetic material;

b) injecting current into the electromagnet to capture the ferromagnetic material;

20 c) displacing the ferromagnetic material captured in step b), along the path;  
and

d) releasing the ferromagnetic material displaced in step c) by stopping the step of injecting current into the electromagnet.

13. A method for transferring a ferromagnetic ribbon from a ferromagnetic ribbon roll mounted on a first reel to a first mandrel, comprising the steps of:

a) positioning the first reel at a first unrolling position;

- b) securing a free end of the ribbon roll on the first reel by means of a ribbon retention mechanism having retaining elements movable between a retaining position in which the free end of the ribbon roll is secured on the first reel and a releasing position in which the free end of the ribbon roll is free from the first reel;
- c) positioning an electromagnet proximate to the first reel;
- d) rotating the reel with the free end secured in step b);
- 10 e) after step d), simultaneously triggering the retaining elements from the retaining position to the releasing position to free the free end of the ribbon, and injecting current into the electromagnet to capture the free end of the ribbon;
- f) displacing the free end captured in step e) along a path proximate to the first mandrel at a first rolling up position;
- g) simultaneously releasing the free end of the ribbon by stopping the step of injecting current in to the electromagnet, injecting a current by means of a controllable current source into a mandrel electromagnet located in said mandrel, to urge said free end onto the mandrel, and rotating said mandrel to roll up said ribbon on said mandrel; and
- 20 h) cutting the ferromagnetic ribbon when a predetermined diameter of ferromagnetic ribbon rolled up on the mandrel has been attained.
14. The method according to claim 13, further comprising the step of:
- i) securing a free end of the ferromagnetic ribbon rolled up on the mandrel, obtained after the cutting step h), onto the ribbon roll on the mandrel.

15. The method according to claim 14, wherein, in step i), the step of securing comprises the step of securing the free end of the ribbon roll on the mandrel by means of a second ribbon retention mechanism having retaining elements movable between a retaining position in which the free end of the ribbon roll on the mandrel is secured on the mandrel and a releasing position in which the free end of the ribbon roll on the mandrel is free from the mandrel.

16. The method according to claim 14, wherein, in step i), the step of securing comprises the step of welding the free end of the ribbon roll on the mandrel onto said  
10 ribbon roll on the mandrel.

17. The method according to claim 13, further comprising the steps of:

j) between steps g) and h), positioning a second mandrel at a second rolling up position proximate to the path of the ribbon between the first reel and the first mandrel;

k) simultaneously with step h), injecting a current by means of a second controllable current source into a second mandrel electromagnet located in said second mandrel, to urge the free end of the ribbon from the first reel cut in step h) onto the second mandrel, and rotating said second mandrel to roll  
20 up said ribbon on said second mandrel;

l) removing the first mandrel from the first rolling up position;

m) moving the second mandrel from the second rolling up position to the first rolling up position;

n) cutting the ferromagnetic ribbon when a second predetermined diameter of ferromagnetic ribbon rolled up on the second mandrel positioned in the second position has been attained; and

o) repeating steps j) to n), until the reel positioned in the first unrolling position is empty, to unroll and roll up the ribbon roll on a plurality of mandrels.

18. The method according to claim 17, further comprising the steps of:

p) providing a second reel having a second ribbon roll at a second unrolling position proximate to the path of the ribbon between the first reel and the first mandrel;

q) securing a free end of the second ribbon roll on the second reel by means of a second ribbon retention mechanism having retaining elements movable between a retaining position in which the free end of the second ribbon roll is secured on the second reel and a releasing position in which the free end of the second ribbon roll is free from the second reel;

r) rotating the second reel with the free end secured in step q);

s) during the repeating step o) before the first reel becomes empty, triggering the retaining elements of the second reel from the retaining position to the releasing position to free the free end of the second ribbon roll and joining the free end of the second ribbon with the first ribbon of the first reel;

t) after step s), removing the first reel from the first unrolling position, after the first reel is emptied;

u) after step t), moving the second reel from the second unrolling position to the first unrolling position; and

v) repeating steps p) to u) continuously, to unroll ribbon rolls continuously from the reels.

19. The method according to claim 18, wherein, in step s), the step of joining comprises the steps of:

- iii) injecting a current by means of a controllable current source into an electromagnet located in an attractor roller, to urge the free end of the second ribbon onto the first ribbon; and
- iv) after step i) welding the first and second ribbons together.

20. The method according to claim 19, wherein, in step ii), the step of welding is carried out by a rotating welder which is mounted on a shaft and comprises a plurality of conductor discs separated by insulating spacer discs, each conductor disc having a narrow tip protruding outwardly from the shaft, the conductor discs being electrically connected such that current polarity alternates between adjacent  
10 conductor discs, and the tips of the conductor discs being pressed against the first and second ribbons.

21. The method according to any one of claims 13 to 20, further comprising the steps of:

AA) positioning an electromagnet of step c) proximate to debris of the ribbon generated upon breakage of the ribbon between the first reel and the first mandrel;

BB) injecting current into the electromagnet of step c) to capture the debris;

CC) displacing the debris captured in step BB) to a disposal location; and

20 DD) releasing the debris at the disposal location by stopping the step of injecting current into the electromagnet of step c).

22. A system for transferring a ferromagnetic ribbon from a ferromagnetic ribbon roll mounted on a first reel to a first mandrel, comprising:

a first positioning system for positioning the first reel at a first unrolling position;

a first ribbon retention mechanism having retaining elements movable between a retaining position in which a free end of the ribbon roll is secured

on the first reel and a releasing position in which the free end of the ribbon roll is free from the first reel;

a first electromagnet;

a controllable displacement system for displacing the first electromagnet along a path;

a first controllable current source for injecting current into said first electromagnet;

a first controller for controlling the controllable displacement system and the controllable current source to sequentially capture, displace and release the ribbon as said first electromagnet moves along said path;

10 a first controllable motor for rotating the first reel;

a first triggering system for triggering the retaining elements from the retaining position to the releasing position to free the free end of the ribbon;

a second controller for controlling the first triggering system, the first controllable current source and the first controllable motor, for simultaneously triggering the retaining elements from the retaining position to the releasing position as the first reel is rotating to free the free end of the ribbon as current is injected into the first electromagnet to capture the free end of the ribbon;

a second positioning system for positioning the first mandrel at a first rolling up position;

20 a second electromagnet located in said first mandrel;

a second controllable motor to rotate the first mandrel;

a second controllable current source for injecting a current into the second electromagnet;

a third controller for controlling the second controllable current source and the second controllable motor, to urge a free end of the ribbon roll as the first mandrel is rotating thereby rolling up the cuttable ferromagnetic ribbon roll on the first mandrel; and

a cutter for cutting the ferromagnetic ribbon when a predetermined diameter of ferromagnetic ribbon rolled up on the first mandrel has been attained.

30

23. The system according to claim 22, further comprising a securing apparatus for securing a free end of the ferromagnetic ribbon rolled up on the mandrel, obtained after cutting by the cutter, onto the ribbon roll on the mandrel.
24. The system according to claim 23, wherein the securing apparatus comprises a second ribbon retention mechanism having retaining elements movable between a retaining position in which the free end of the ribbon roll on the mandrel is secured on the mandrel and a releasing position in which the free end of the ribbon roll on the mandrel is free from the mandrel.
- 10 25. The system according to claim 23, wherein the securing apparatus comprises a welder for welding the free end of the ribbon roll on the mandrel onto said ribbon roll on the mandrel.
26. The system according to claim 22, further comprising:  
a second positioning system for positioning a second mandrel between a second rolling up position proximate to the path of the ribbon between the first reel and the first mandrel, and the first rolling up position;  
20 a third electromagnet located in said second mandrel;  
a third controllable motor to rotate the second mandrel;  
a third controllable current source for injecting a current into the third electromagnet;  
a fourth controller for controlling the third controllable current source and the third controllable motor, to urge a free end of the ribbon roll on the second mandrel as the second mandrel is rotating thereby rolling up the cuttable ferromagnetic ribbon roll on the second mandrel.
27. The system according to claim 26, further comprising:

a third positioning system for positioning a second reel having a second ribbon roll between a second unrolling position proximate to the path of the ribbon between the first reel and the first mandrel, and the first unrolling position;

a second ribbon retention mechanism having retaining elements movable between a retaining position in which the free end of the second ribbon roll is secured on the second reel and a releasing position in which the free end of the second ribbon roll is free from the second reel;

a fourth controllable motor for rotating the second reel;

10 a second triggering system for triggering the retaining elements from the retaining position to the releasing position to free the free end of the ribbon;

a fifth controller for controlling the second triggering system and the fourth controllable motor, for simultaneously triggering the retaining elements from the retaining position to the releasing position as the second reel is rotating to free the free end of the ribbon;

an attractor roller;

a fourth electromagnet located in said attractor roller;

a fifth controllable motor to rotate the attractor roller;

20 a fourth controllable current source for injecting current into the fourth electromagnet;

a rotating welder for welding the first and second ribbons together; and

a sixth controller for controlling the fourth controllable current source, the fifth controllable motor, and the rotating welder, to urge the free end of the second ribbon and the first ribbon onto the attractor roller, and weld the first and second ribbons together.

28. The system according to claim 27, wherein the rotating welder is mounted on a shaft and comprises a plurality of conductor discs separated by insulating spacer  
30 discs, each conductor disc having a narrow tip protruding outwardly from the shaft,

the conductor discs being electrically connected such that current polarity alternates between adjacent conductor discs, and the tips of the conductor discs being pressed against the first and second ribbons.

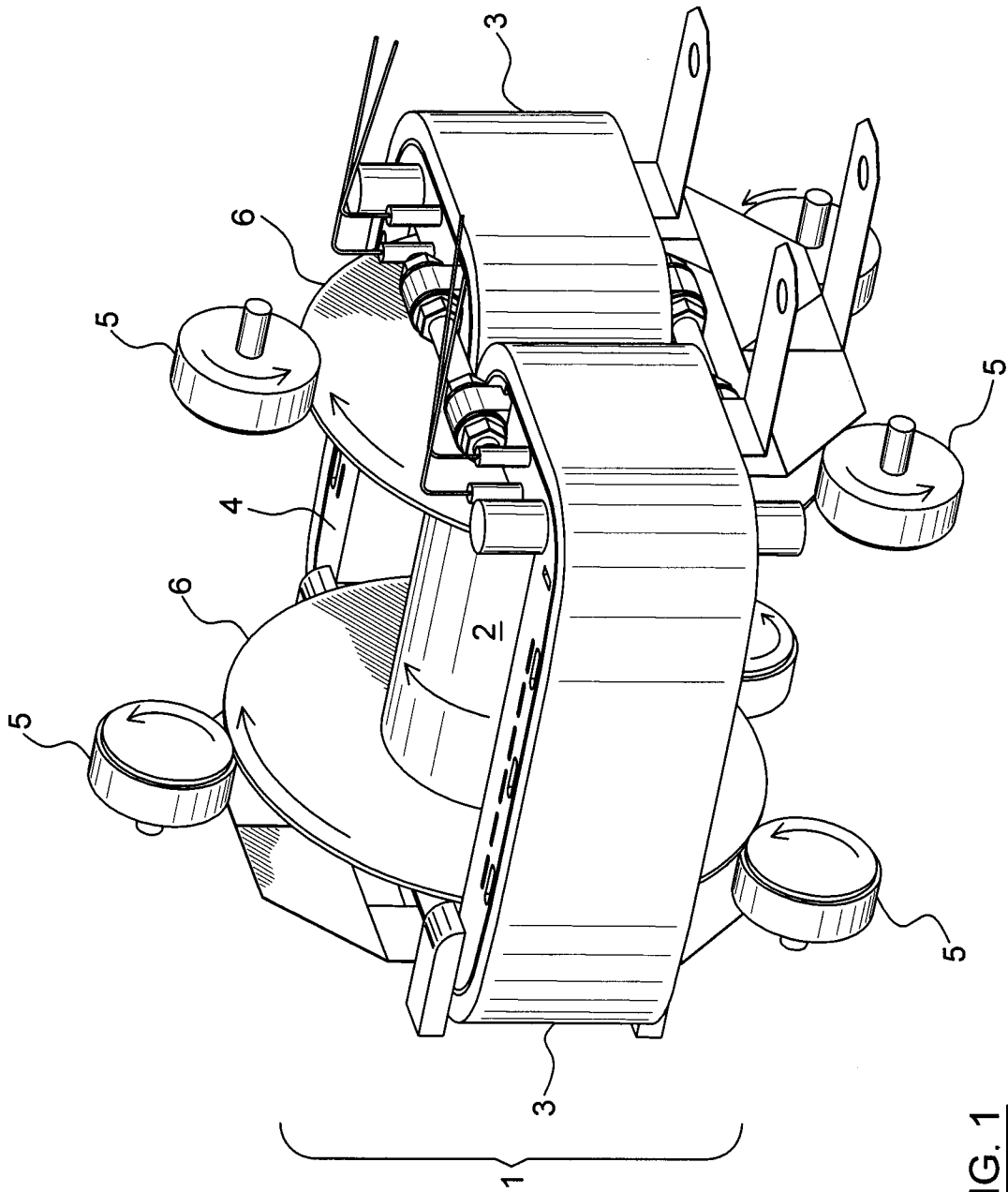

FIG. 1



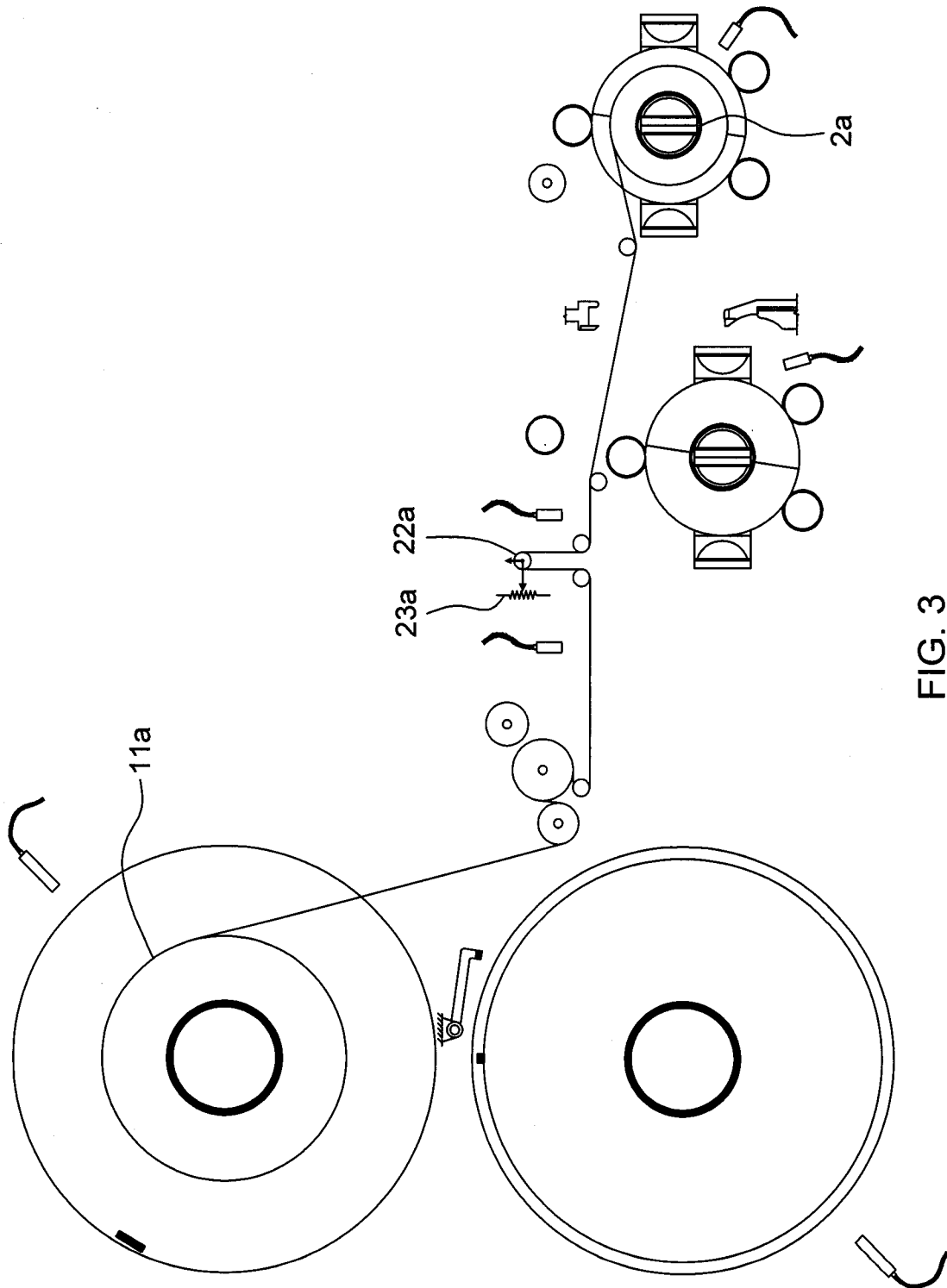

FIG. 3

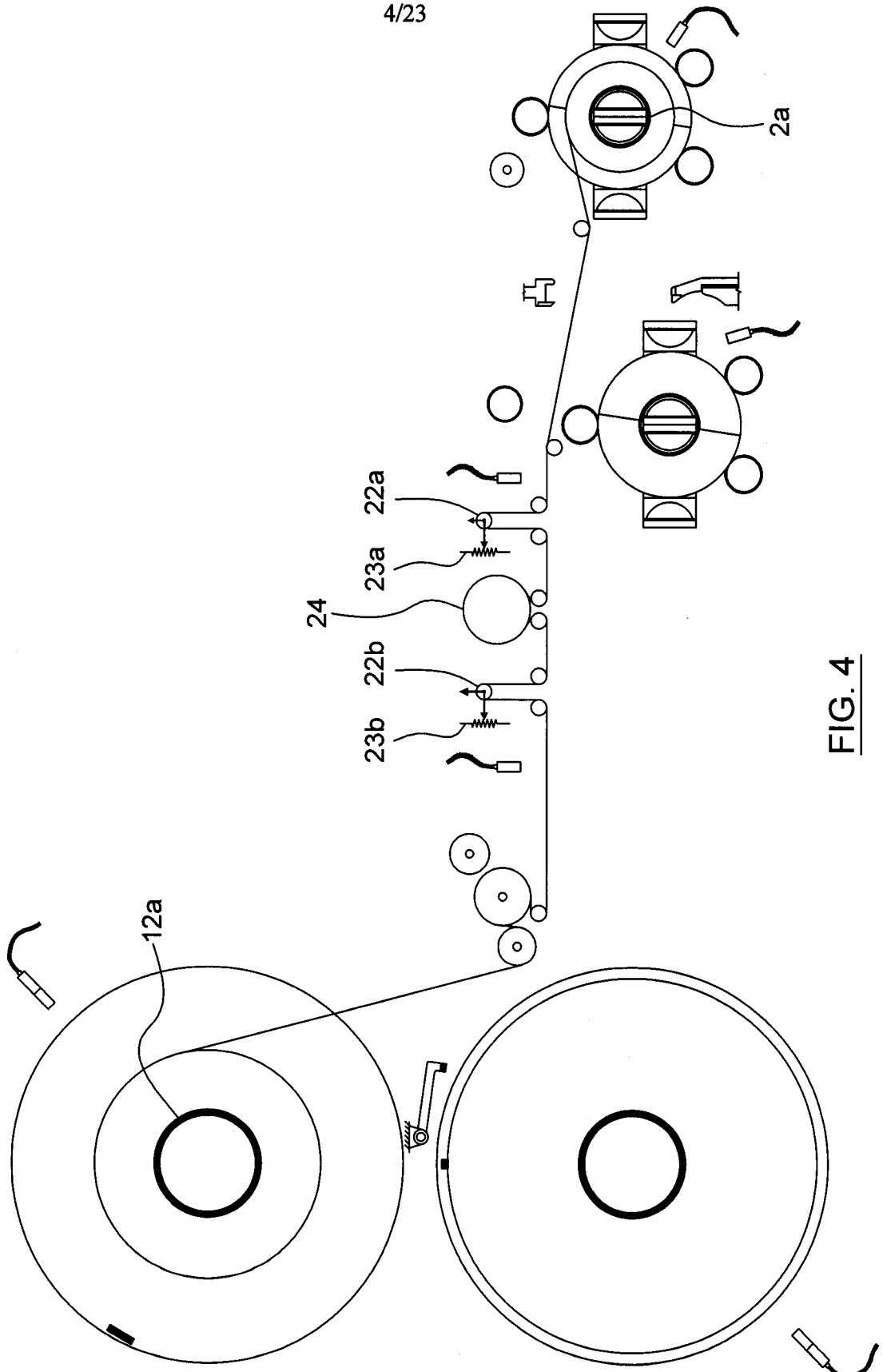

FIG. 4

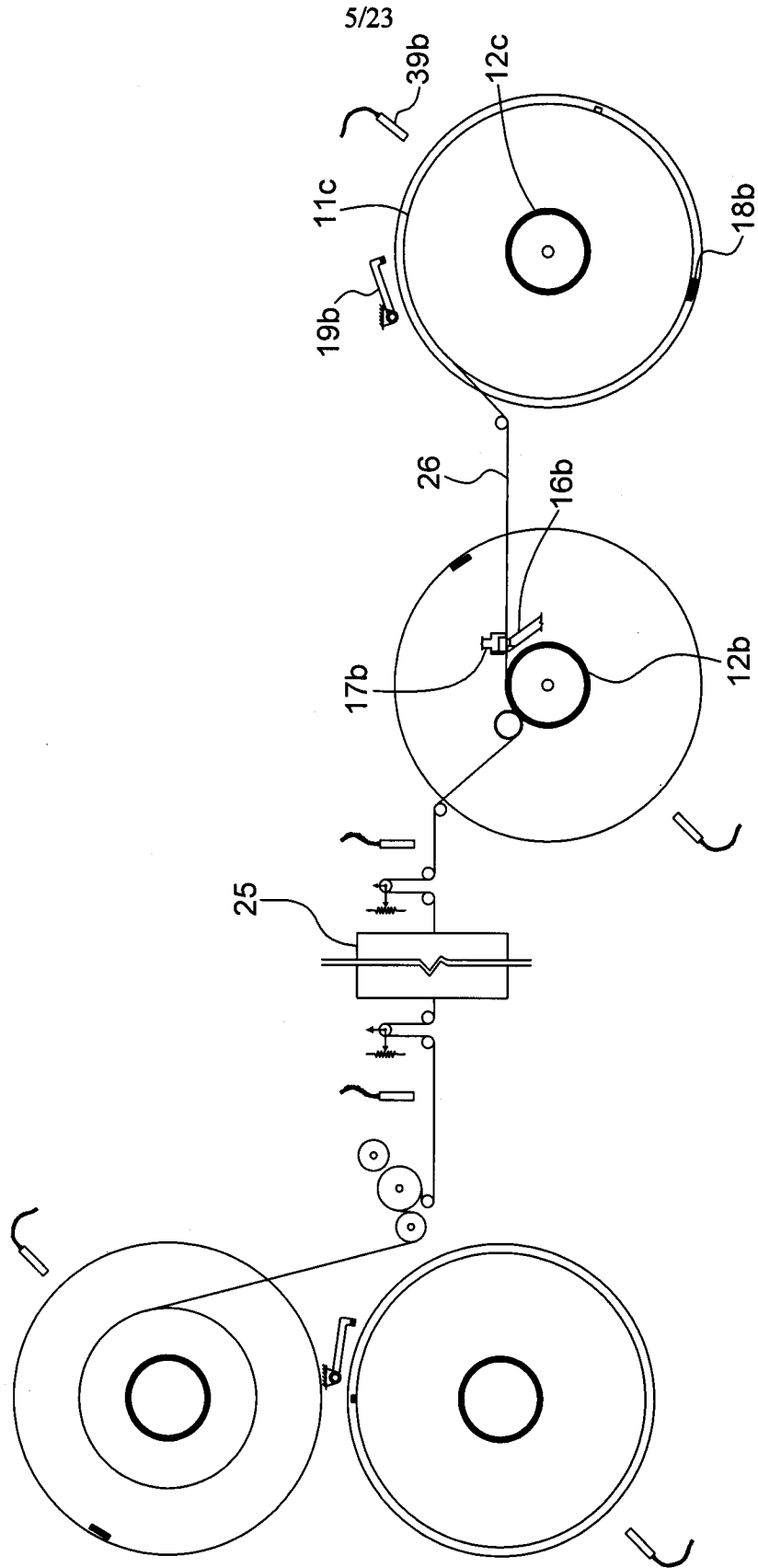

FIG. 5

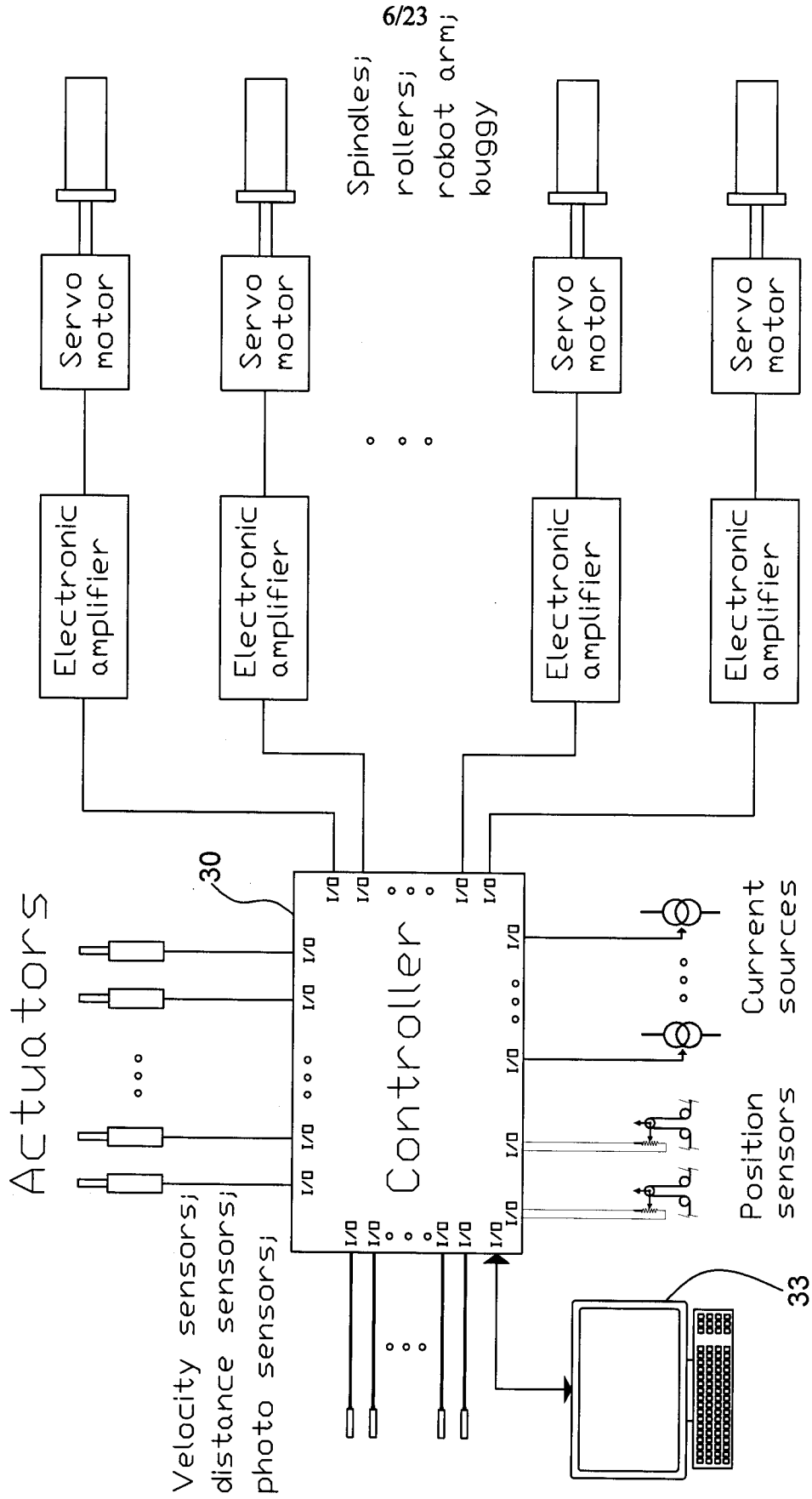
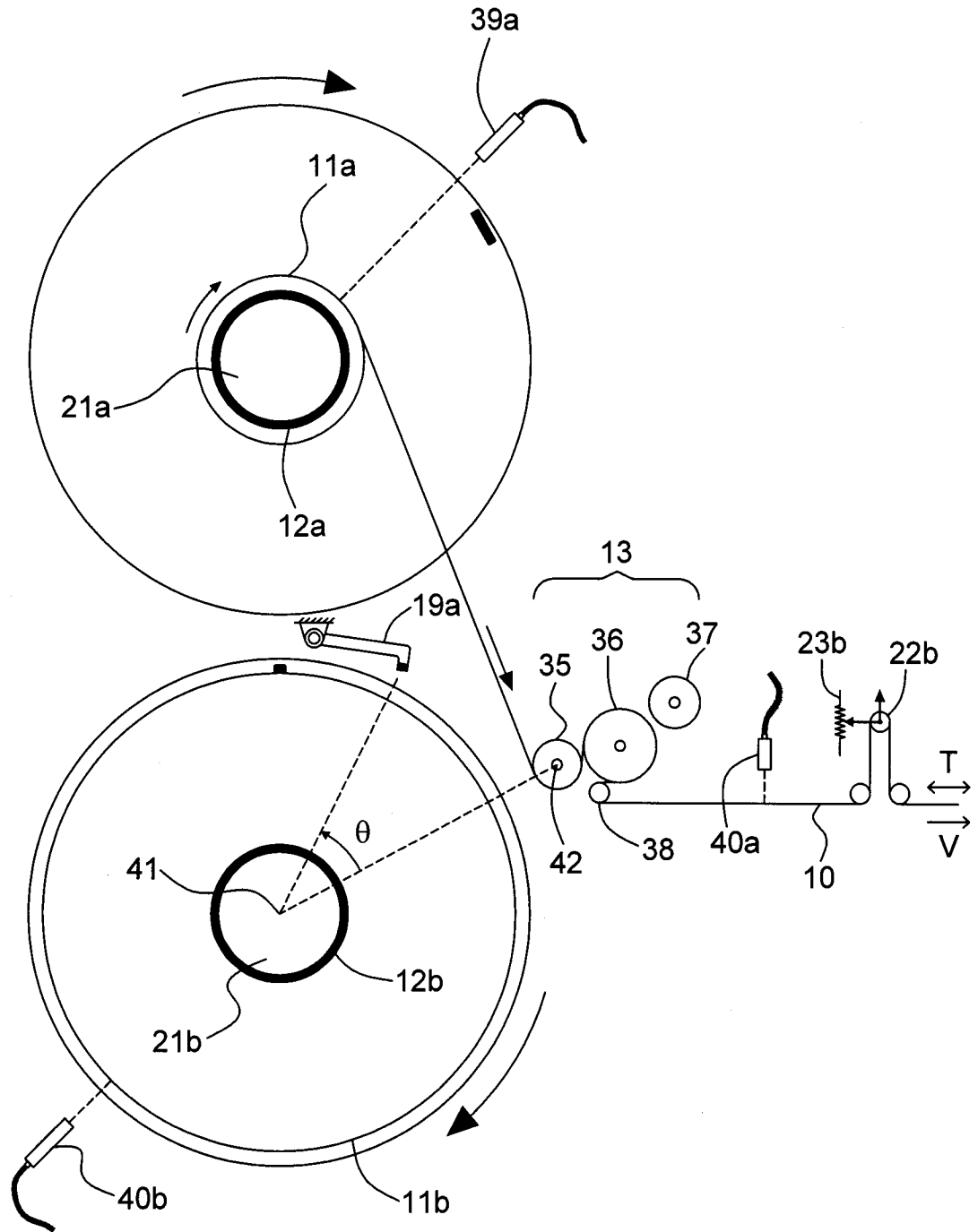

FIG. 6



**FIG. 7**

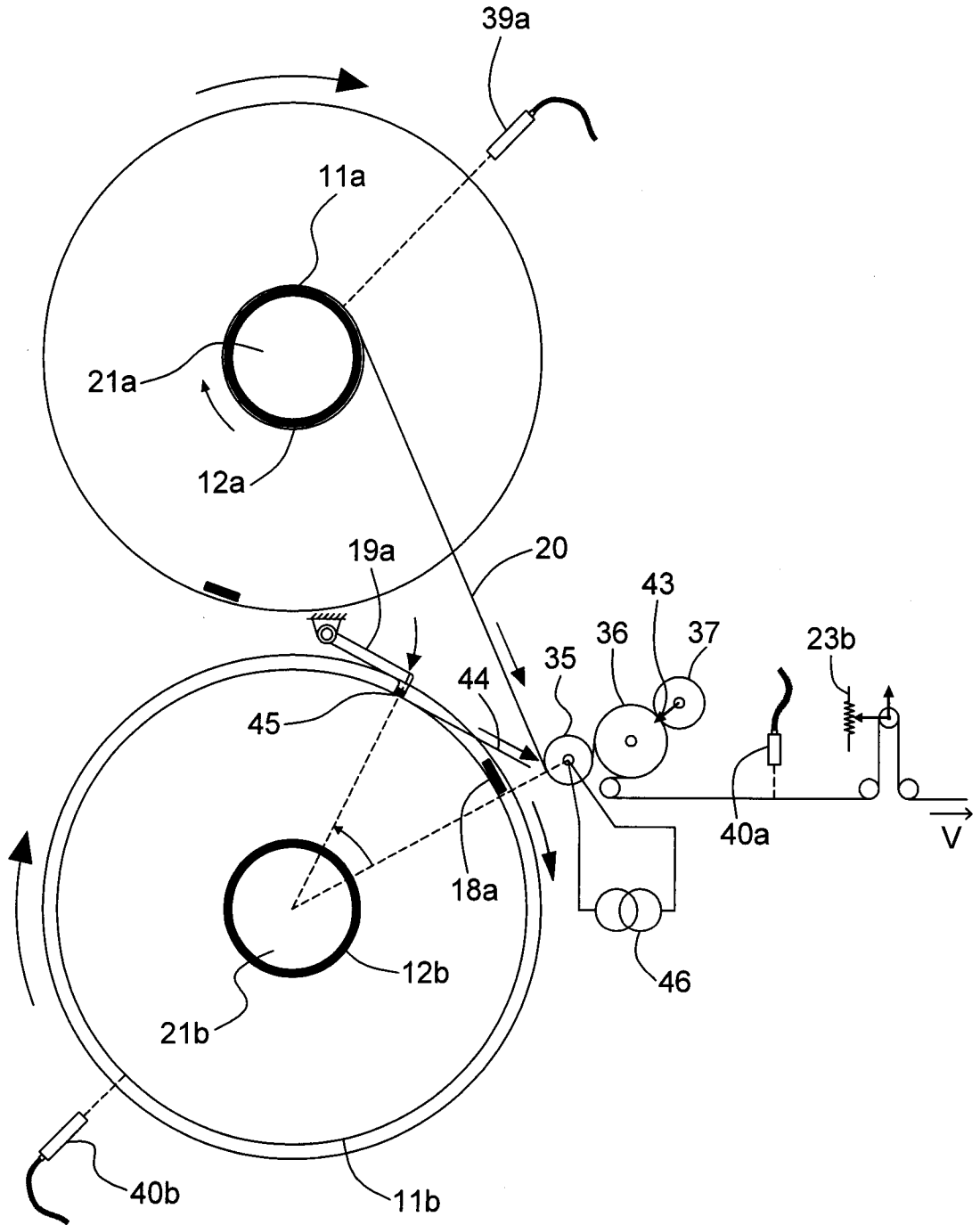

FIG. 8

9/23

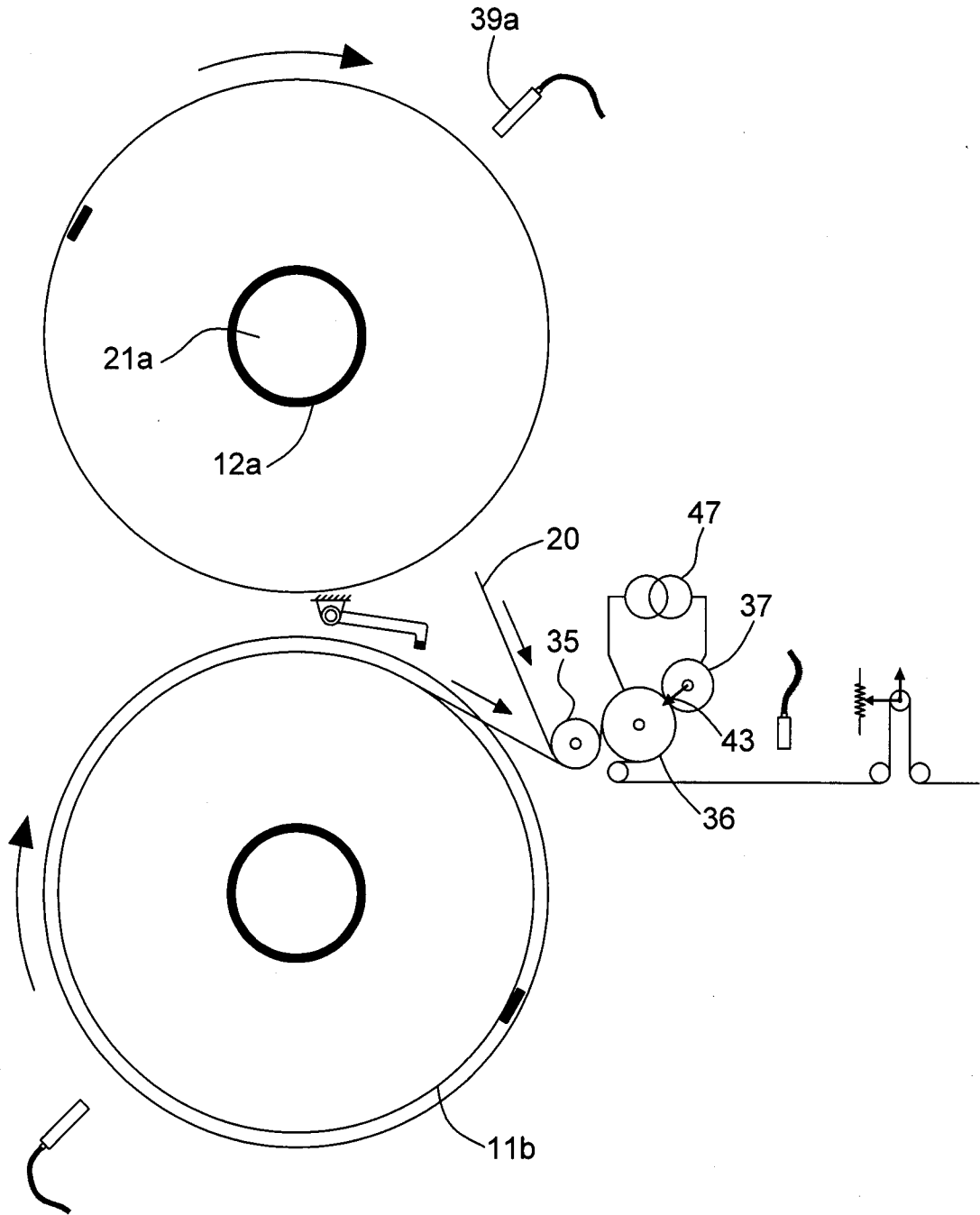

FIG. 9

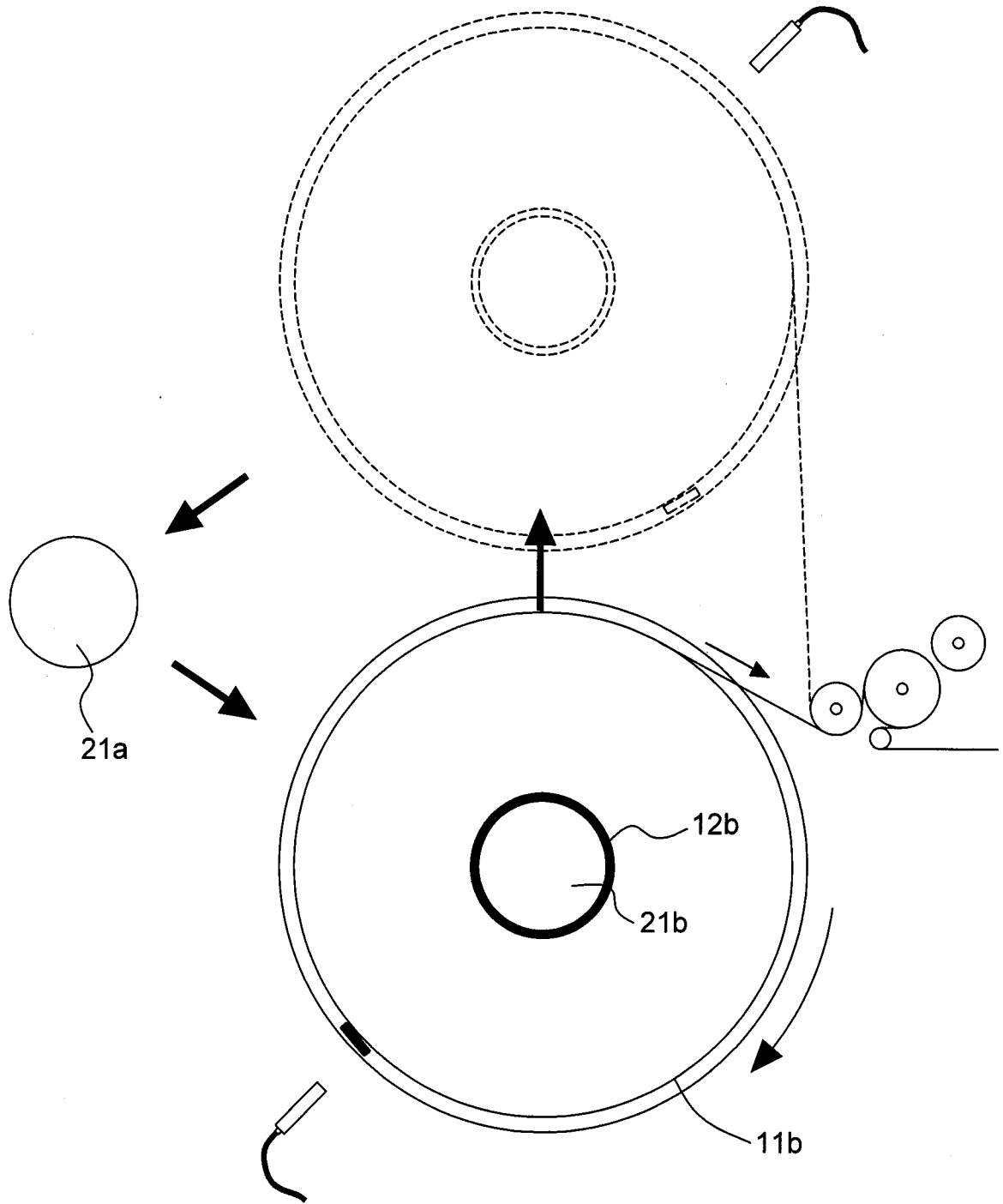

FIG. 10

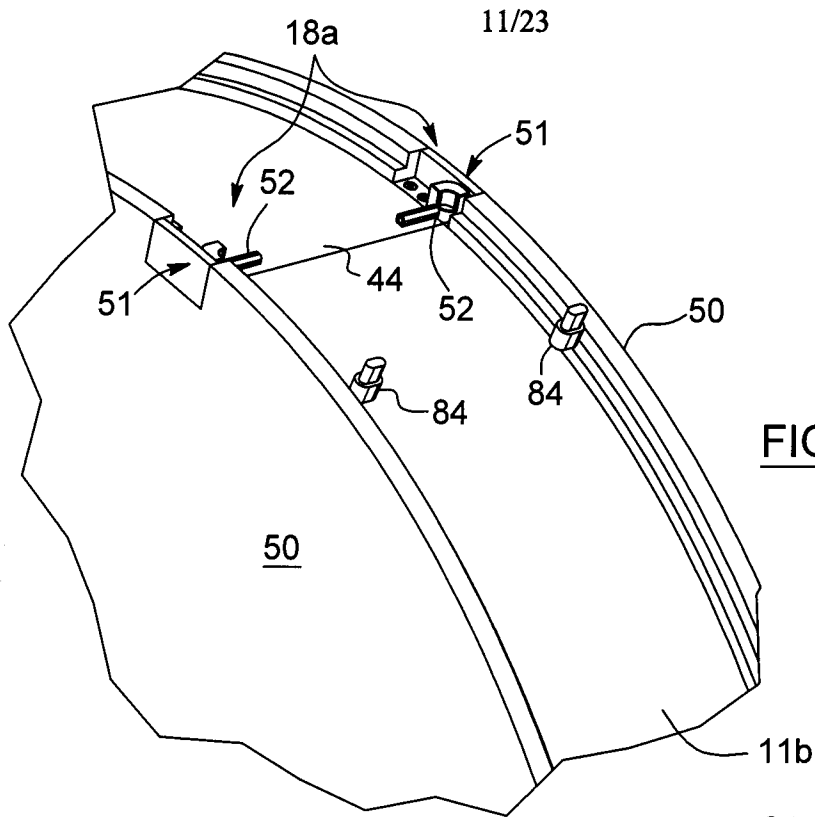

FIG. 11A

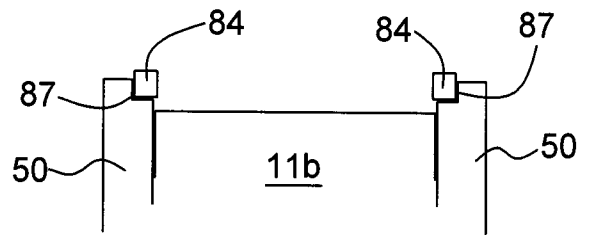

FIG. 11C

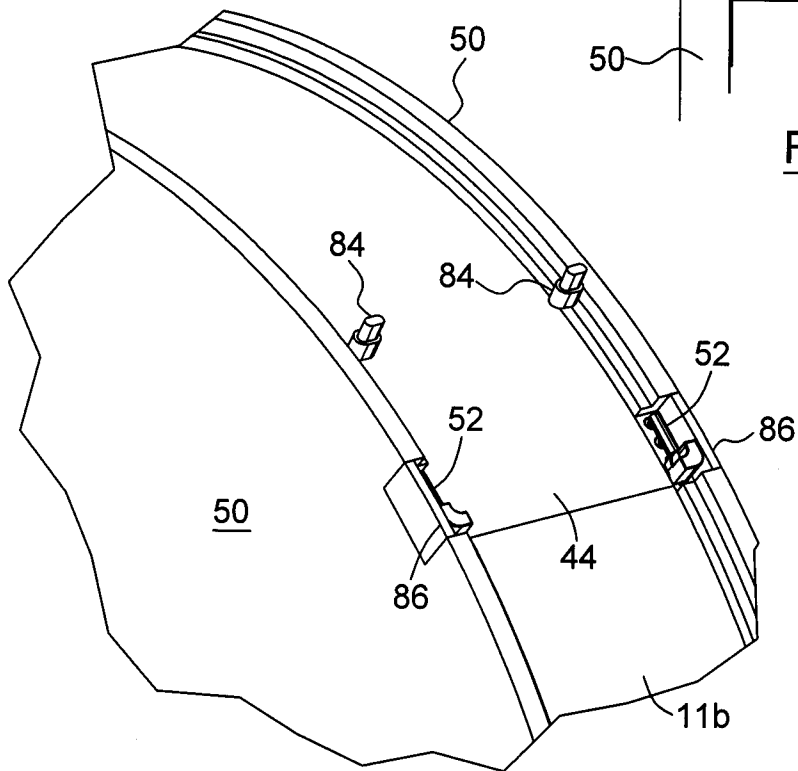
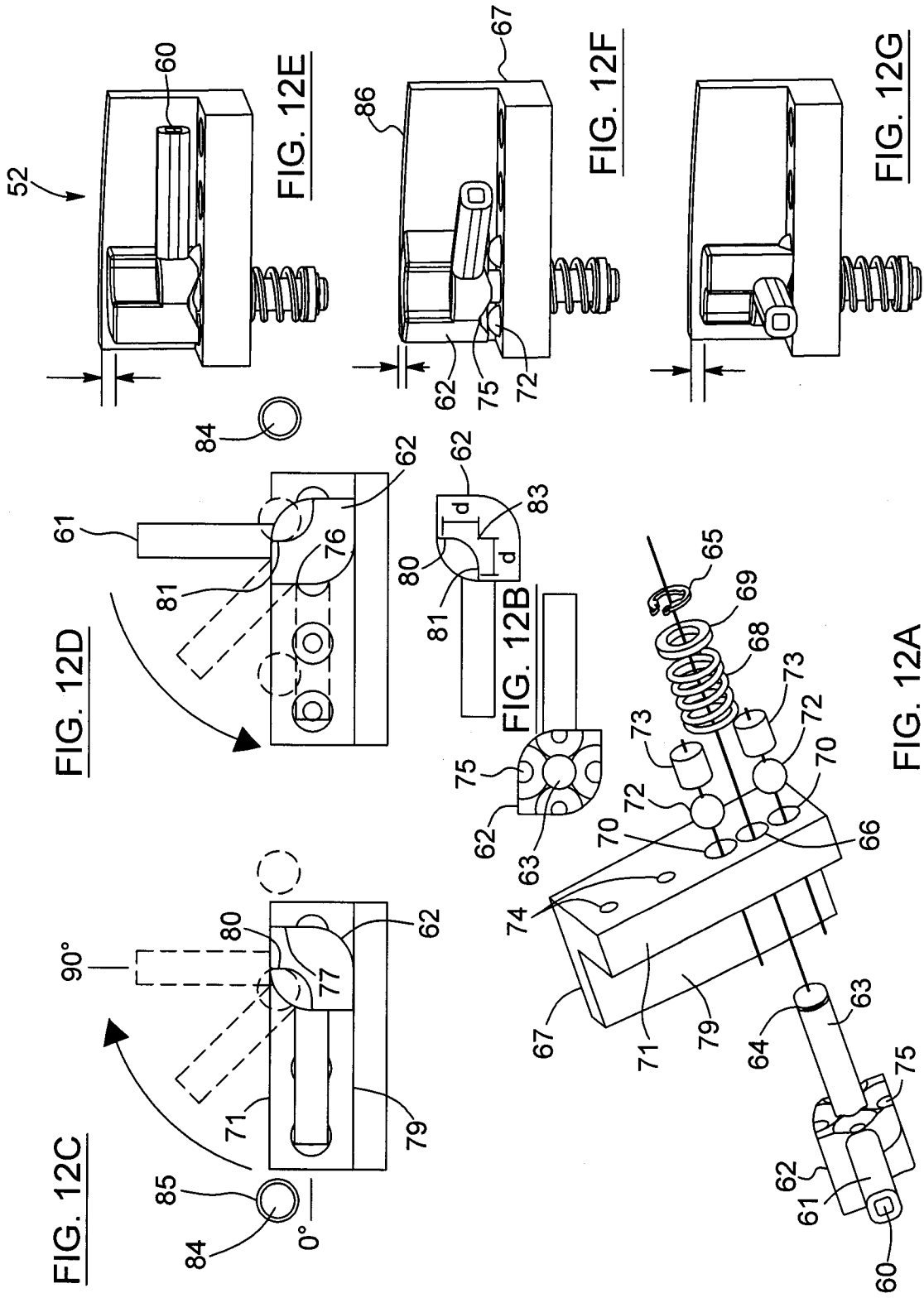

FIG. 11B



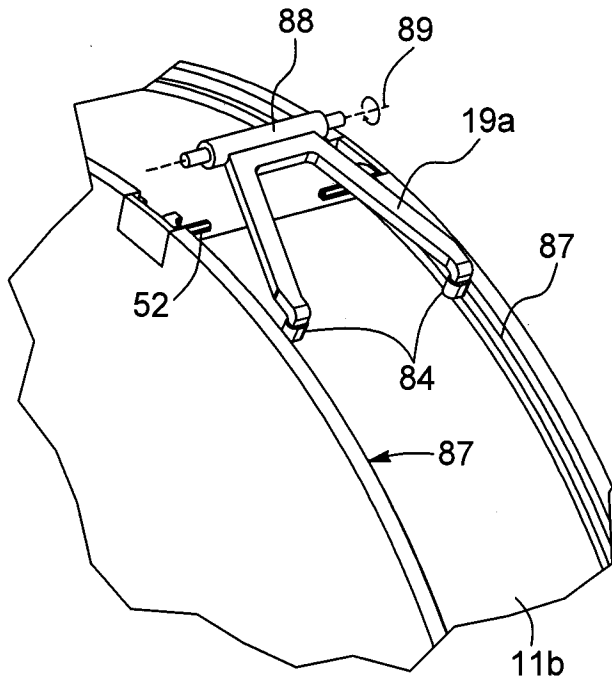

FIG. 13A

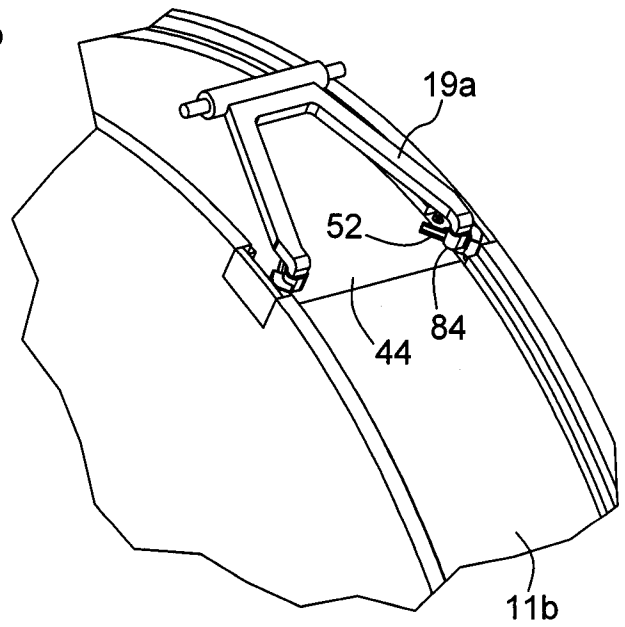

FIG. 13B

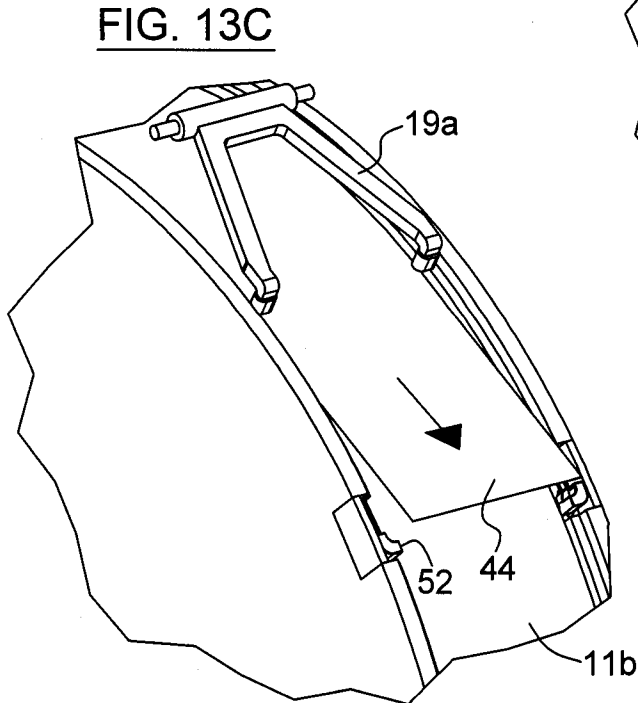

FIG. 13C

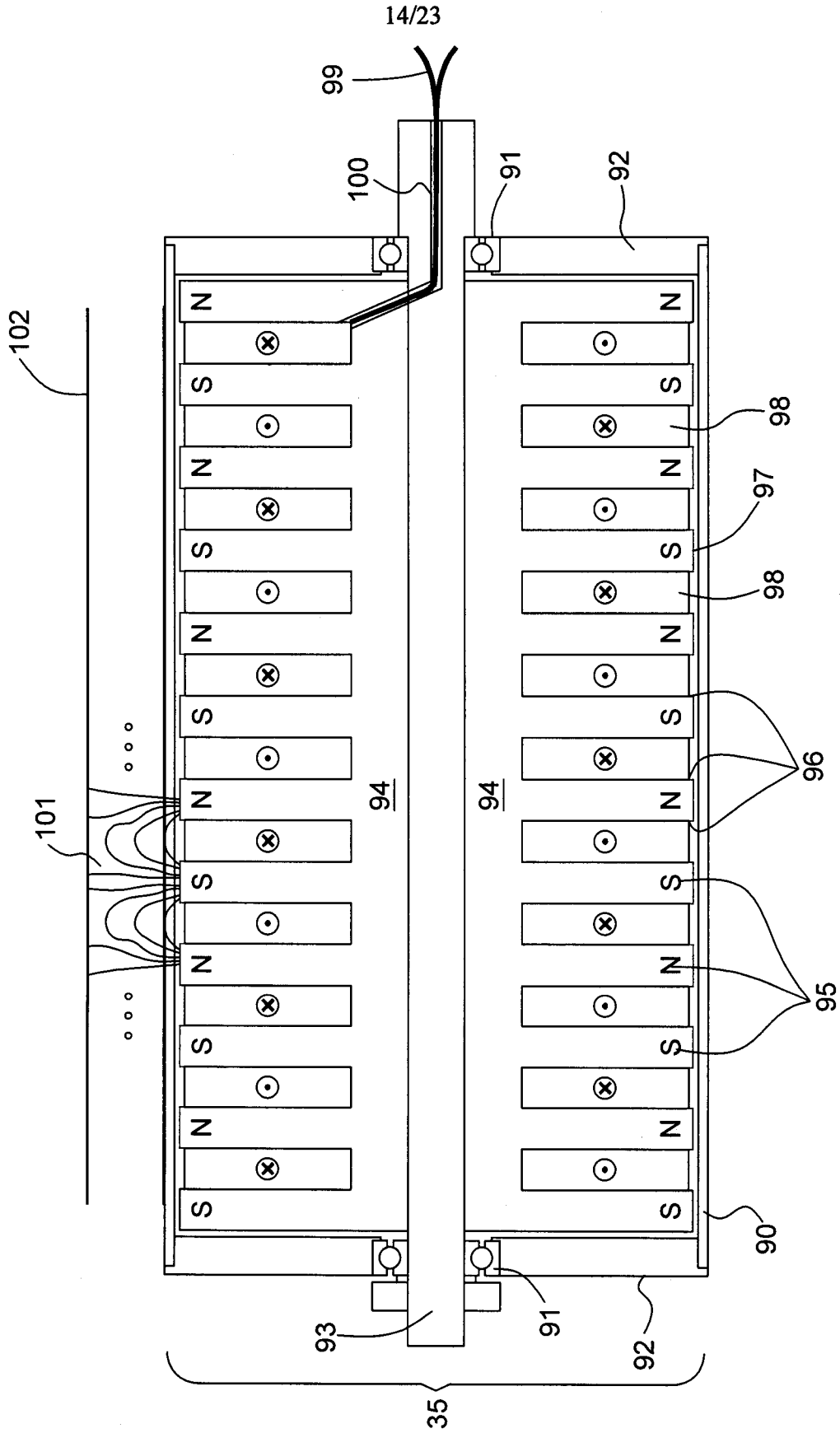

FIG. 14

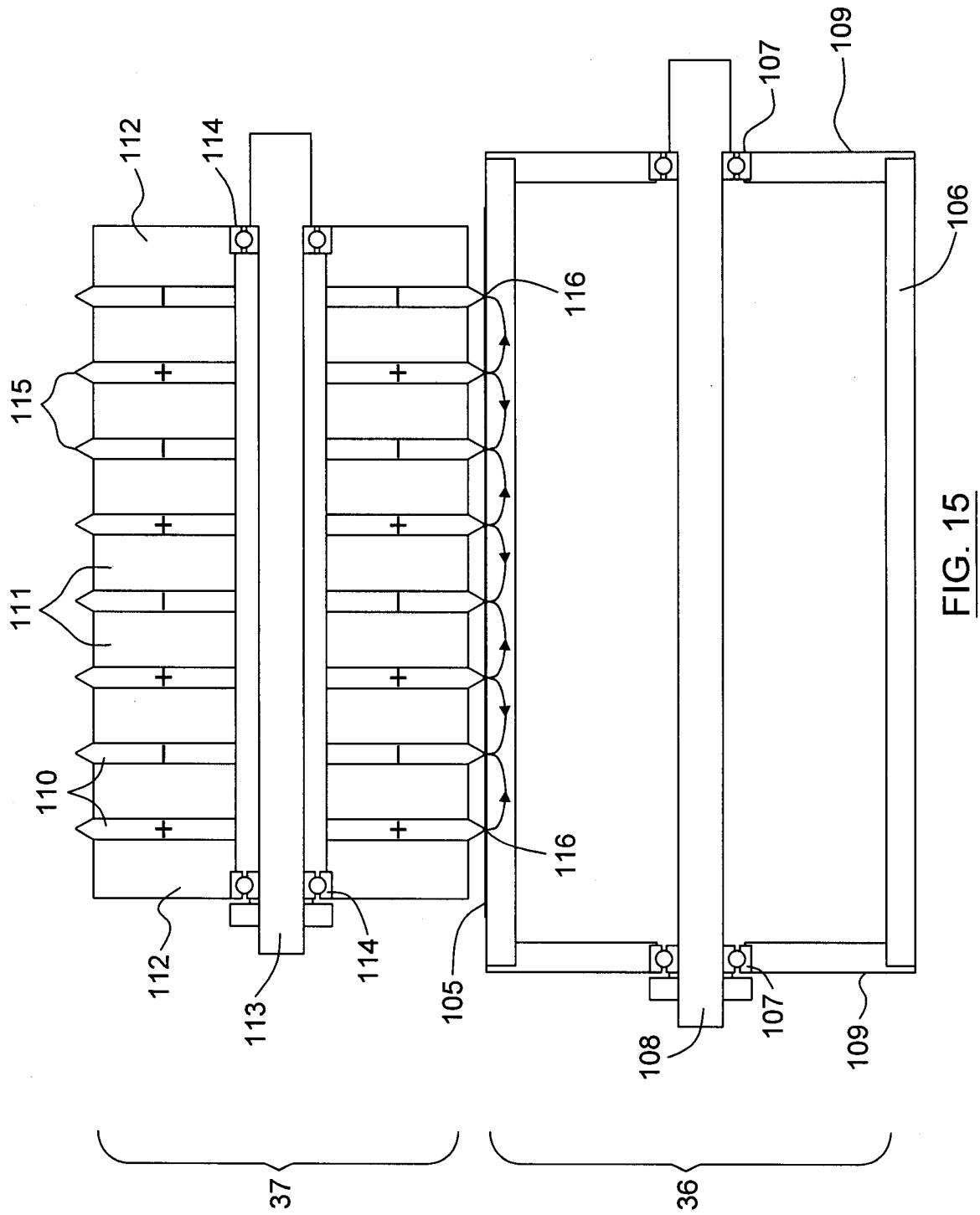

FIG. 15

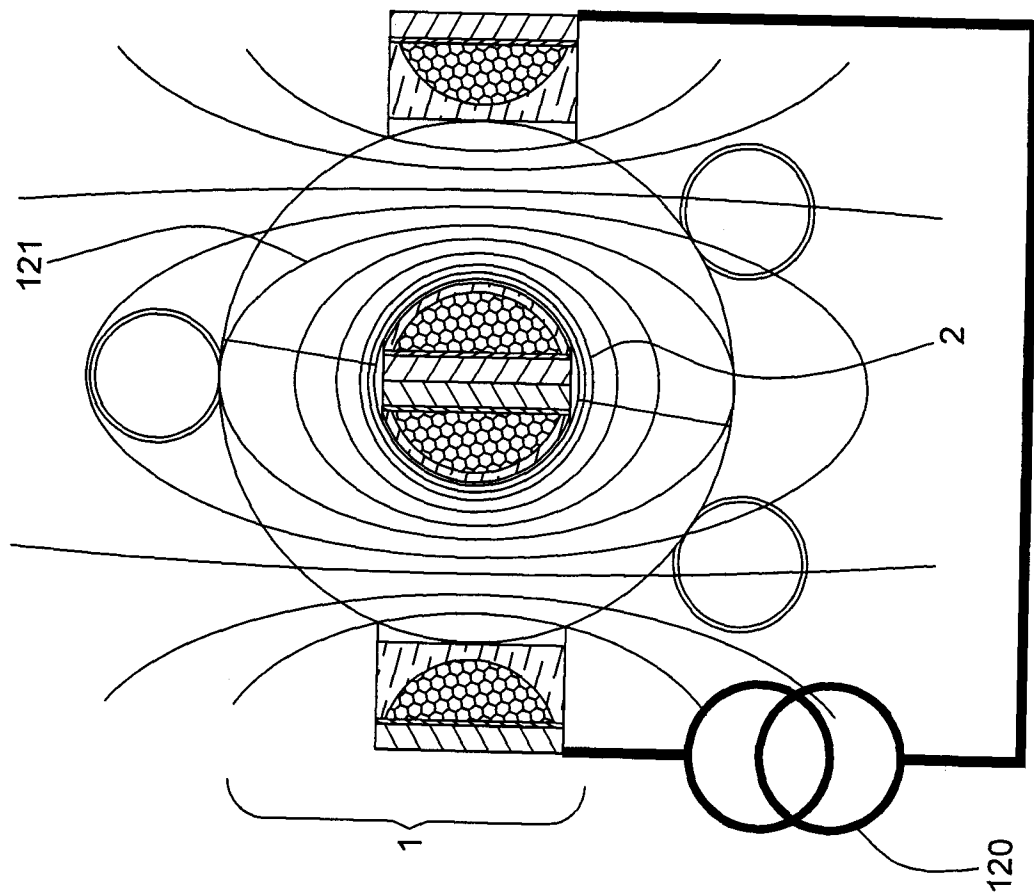

FIG. 16A

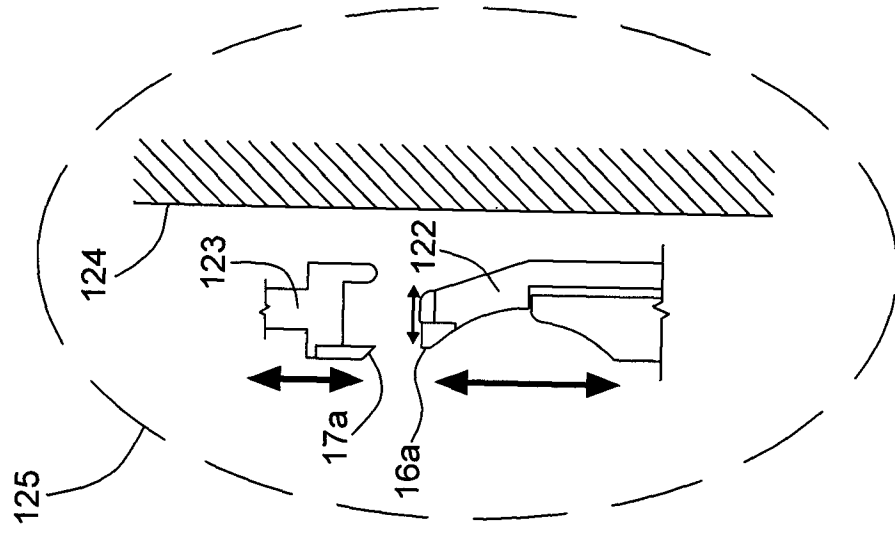

FIG. 16B

17/23

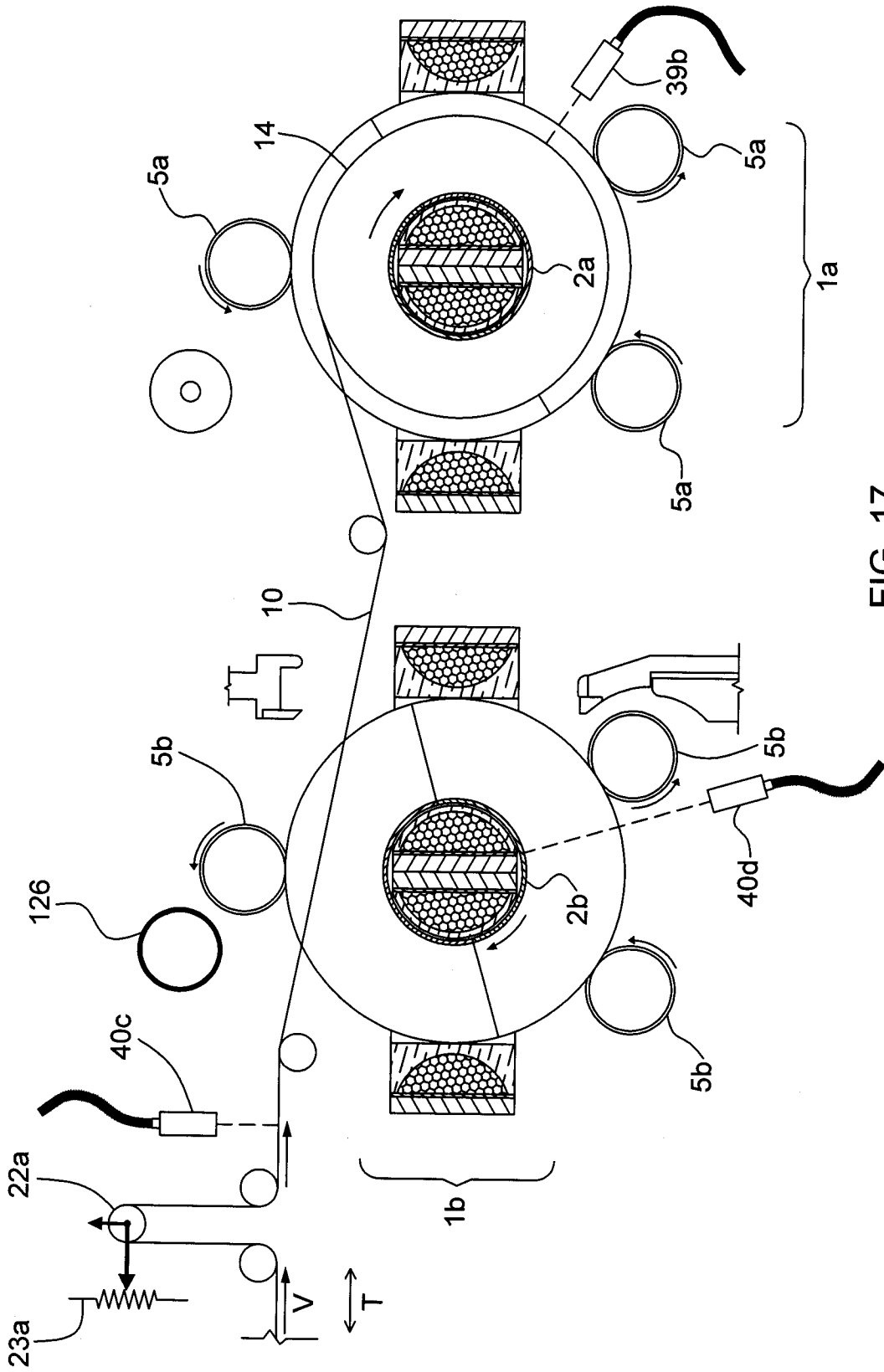

FIG. 17

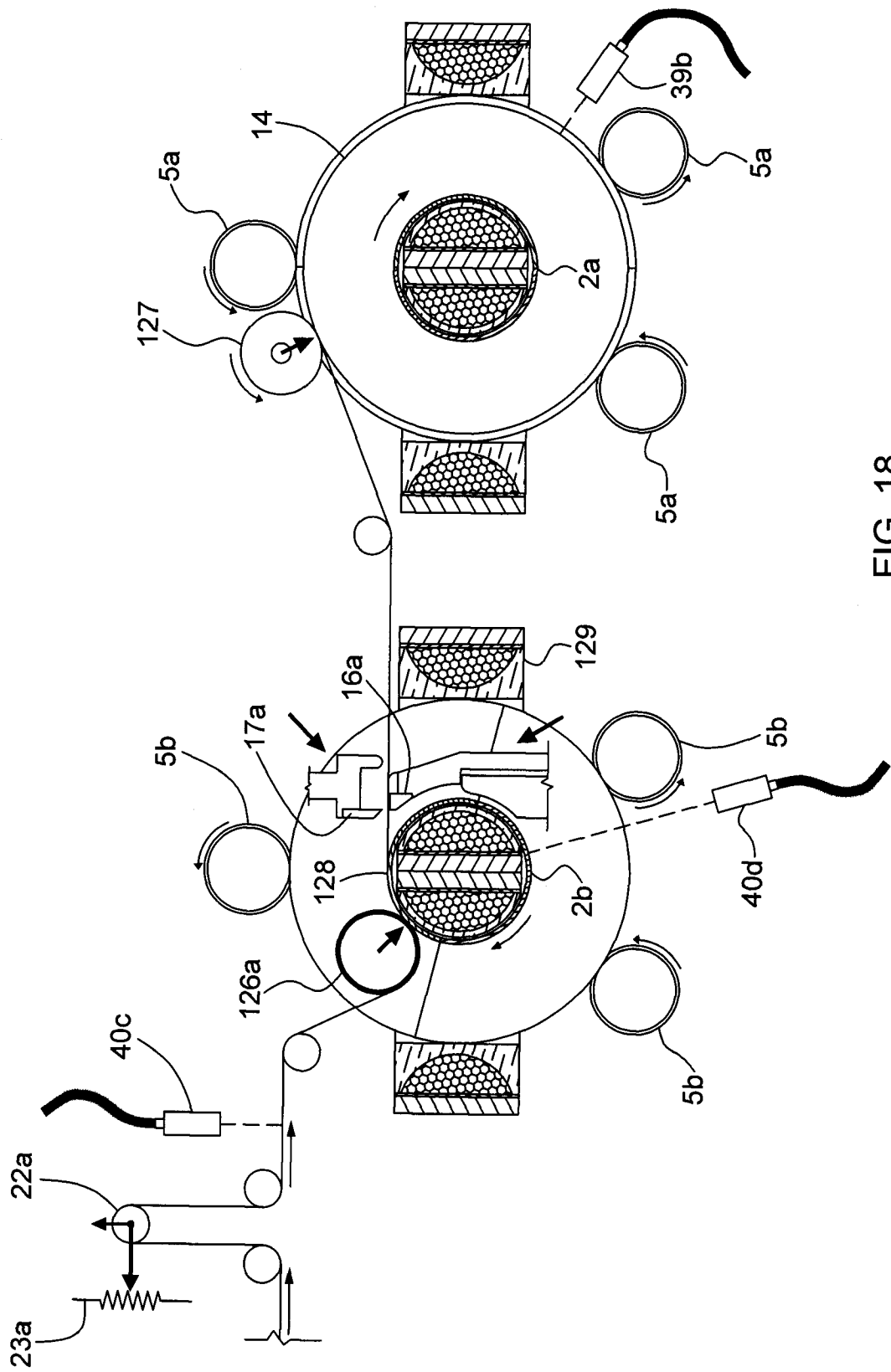

FIG. 18

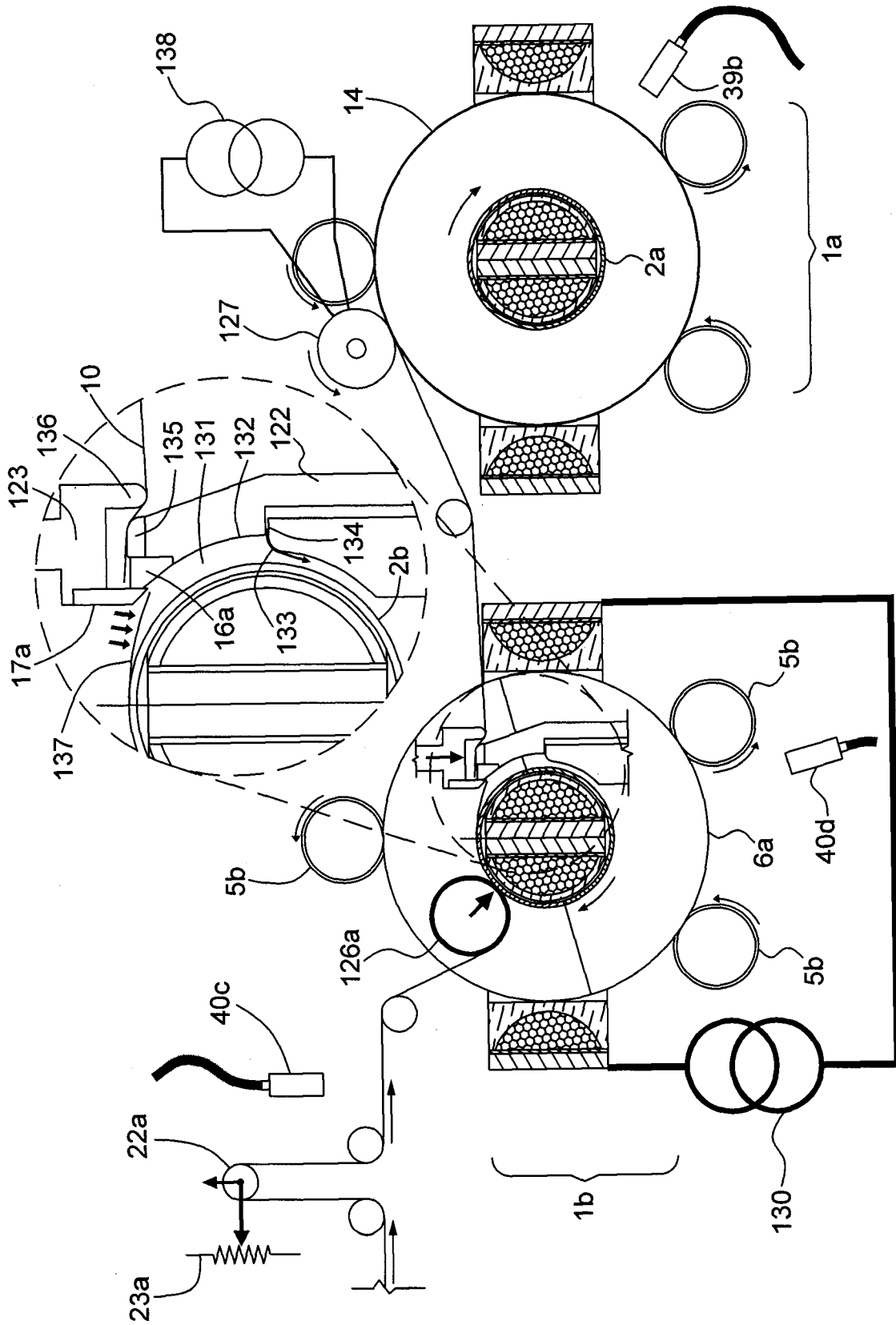

FIG. 19

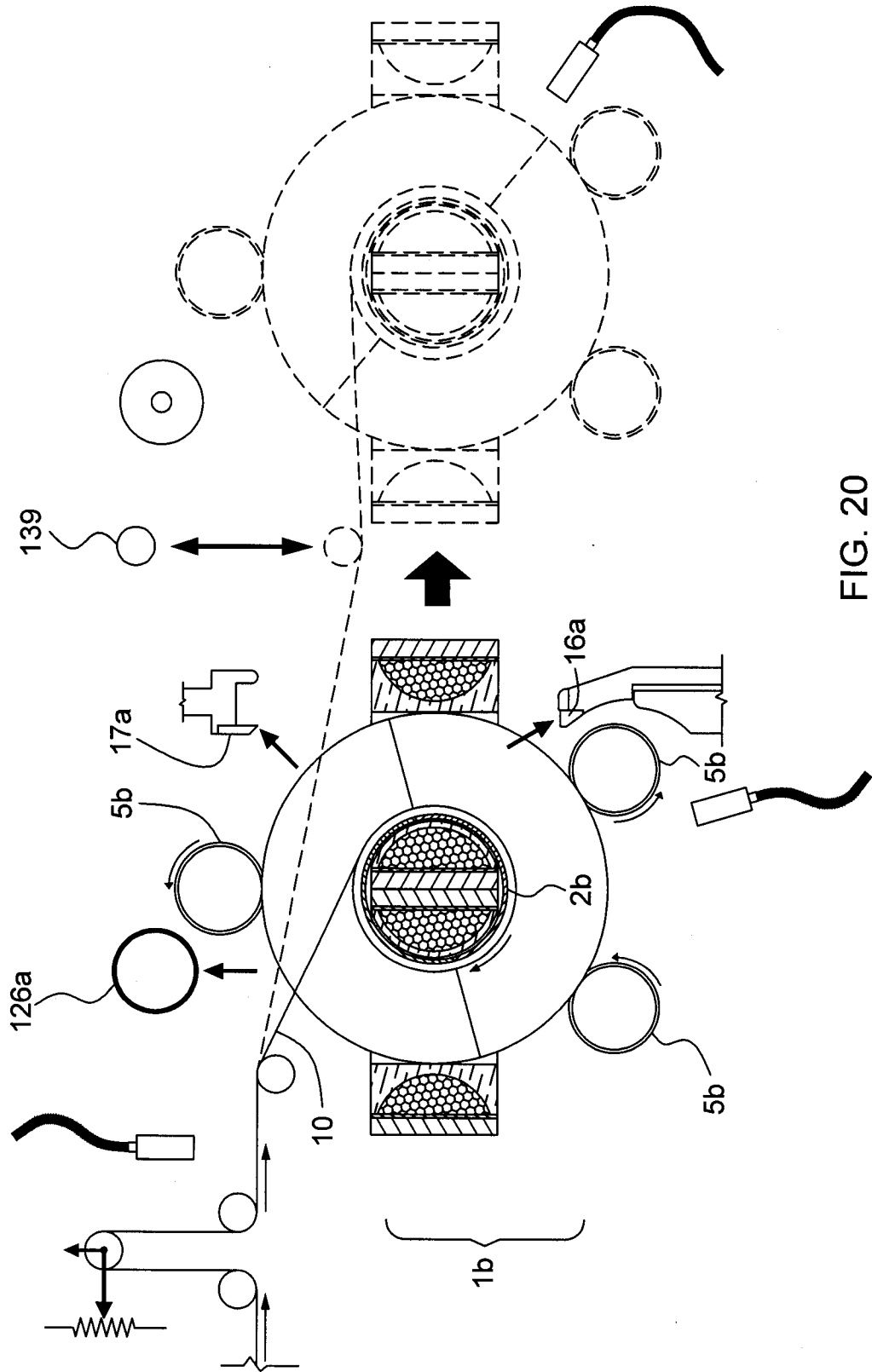

FIG. 20



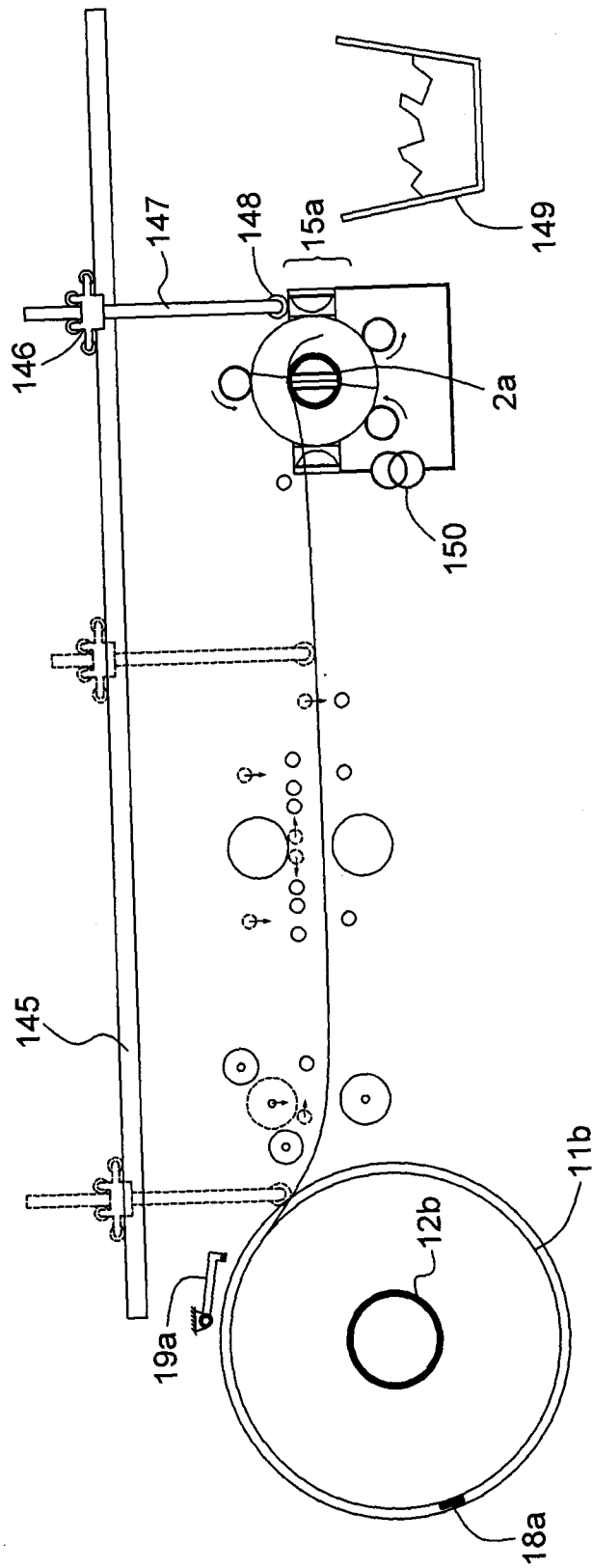

FIG. 22

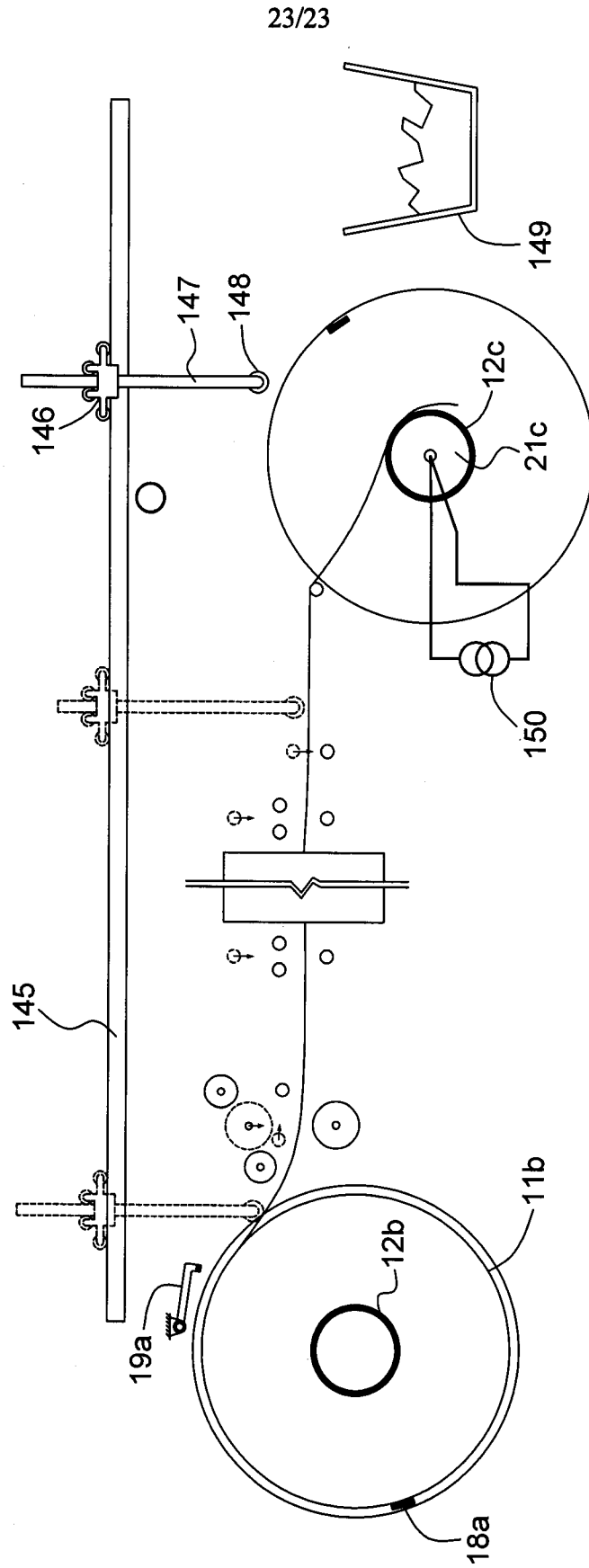

FIG. 23

## INTERNATIONAL SEARCH REPORT

International application No.  
PCT/CA2011/000587

## A. CLASSIFICATION OF SUBJECT MATTER

IPC: **B65H 75/28** (2006.01) , **B65H 19/00** (2006.01) , **B65H 19/28** (2006.01) , **B65H 65/00** (2006.01) , **B65H 67/08** (2006.01) , **H01F 7/20** (2006.01)

According to International Patent Classification (IPC) or to both national classification and IPC

## B. FIELDS SEARCHED

Minimum documentation searched (classification system followed by classification symbols)

IPC and ECLA: B65H 75/28, B65H 19/00, B65H 19/28, B65H 65/00, B65H 67/08, H01F 7/20, B21C 47/all  
ECLA: B65H 75/28B, B65H 65/00B, B65H 67/08B, 08B4, 08B6, 08C, 08C2

Documentation searched other than minimum documentation to the extent that such documents are included in the fields searched

Electronic database(s) consulted during the international search (name of database(s) and, where practicable, search terms used)

Epoque (EPODOC, English Full-Text), Canadian Patents Database

Keywords: secure, retain, end, ribbon, steel, band, web, sheet, reel, mandrel, spool, bobbin, move, displace, transfer, electromagnet, ferromagnetic, etc.

## C. DOCUMENTS CONSIDERED TO BE RELEVANT

Category*	Citation of document, with indication, where appropriate, of the relevant passages	Relevant to claim No.
X	US 2765908 A (KULKA, T.S.) 09 October 1956 (09-10-1956) - The whole document -	1
X	US 331616 A (COBURN, H.W. et al.) 01 December 1885 (01-12-1885) - The whole document -	1
X	CA2125938 A1 (ACKERMANN, R. et al.) 18 December 1994 (18-12-1994) - The whole document -	1,2
X	US 3650389 A (MOOK, D.G.) 21 March 1972 (21-03-1972) - The whole document -	1,2
A	US 1692789 A (YOUNG, L.) 20 November 1928 (20-11-1928) - Figure 2 -	13,22
A	US 3555474 A (MARCHER J.) 12 January 1971 (12-01-1971) - The whole document -	13,22

 Further documents are listed in the continuation of Box C. See patent family annex.

* Special categories of cited documents :	"T" later document published after the international filing date or priority date and not in conflict with the application but cited to understand the principle or theory underlying the invention
"A" document defining the general state of the art which is not considered to be of particular relevance	"X" document of particular relevance; the claimed invention cannot be considered novel or cannot be considered to involve an inventive step when the document is taken alone
"E" earlier application or patent but published on or after the international filing date	"Y" document of particular relevance; the claimed invention cannot be considered to involve an inventive step when the document is combined with one or more other such documents, such combination being obvious to a person skilled in the art
"L" document which may throw doubts on priority claim(s) or which is cited to establish the publication date of another citation or other special reason (as specified)	"&" document member of the same patent family
"O" document referring to an oral disclosure, use, exhibition or other means	
"P" document published prior to the international filing date but later than the priority date claimed	

Date of the actual completion of the international search

10 August 2011 (10-08-2011)

Date of mailing of the international search report

15 August 2011 (15-08-2011)

Name and mailing address of the ISA/CA  
Canadian Intellectual Property Office  
Place du Portage I, C114 - 1st Floor, Box PCT  
50 Victoria Street  
Gatineau, Quebec K1A 0C9  
Facsimile No.: 001-819-953-2476

Authorized officer

Jean-François Desrosiers (819) 934-6358

**INTERNATIONAL SEARCH REPORT**International application No.  
PCT/CA2011/000587

C (Continuation). DOCUMENTS CONSIDERED TO BE RELEVANT

Category*	Citation of document, with indication, where appropriate, of the relevant passages	Relevant to claim No.
A	WO 83/04340 A1 (McCLEES, R.) 08 December 1983 (08-12-1983) - The whole document -	13,22
A	CA 2439138 A1 (SCHNURR, C.) 31 January 2004 (31-01-2004) - The whole document -	1,13,22

**Box No. II Observations where certain claims were found unsearchable (Continuation of item 2 of the first sheet)**

This international search report has not been established in respect of certain claims under Article 17(2)(a) for the following reasons :

1.  Claim Nos. :  
because they relate to subject matter not required to be searched by this Authority, namely :
  
2.  Claim Nos. :  
because they relate to parts of the international application that do not comply with the prescribed requirements to such an extent that no meaningful international search can be carried out, specifically :
  
3.  Claim Nos. :  
because they are dependent claims and are not drafted in accordance with the second and third sentences of Rule 6.4(a).

**Box No. III Observations where unity of invention is lacking (Continuation of item 3 of first sheet)**

This International Searching Authority found multiple inventions in this international application, as follows :

see extra sheet

1.  As all required additional search fees were timely paid by the applicant, this international search report covers all searchable claims.
2.  As all searchable claims could be searched without effort justifying additional fees, this Authority did not invite payment of additional fees.
3.  As only some of the required additional search fees were timely paid by the applicant, this international search report covers only those claims for which fees were paid, specifically claim Nos. :
4.  No required additional search fees were timely paid by the applicant. Consequently, this international search report is restricted to the invention first mentioned in the claims; it is covered by claim Nos. : 1-2, 13-28

- Remark on Protest**
- The additional search fees were accompanied by the applicant's protest and, where applicable, the payment of a protest fee.
- The additional search fees were accompanied by the applicant's protest but the applicable protest fee was not paid within the time limit specified in the invitation.
- No protest accompanied the payment of additional search fees.

The claims are directed to 3 inventions:

- Group A: Claim 1-2 and 13-28 are directed to an apparatus for securing a free end of a ribbon roll, said apparatus comprising a ribbon retention mechanism having retaining elements movable between a retaining position and a releasing position.
- Group B: Claims 3-10 are directed to an apparatus and method for rolling up a cuttable ferromagnetic ribbon roll, said apparatus comprising an electromagnet located into a mandrel, and a controllable current source for injecting a current into the electromagnet, whereby a free end of the ribbon is urged onto the mandrel while said mandrel is rotated.
- Group C: Claims 11-12 are directed to an apparatus and method for manipulating and displacing ferromagnetic material along a path, said apparatus comprising an electromagnet and a controllable displacement system for displacing the electromagnet along the path, wherein current is injected into the electromagnet to capture the ferromagnetic material before displacing and releasing the ferromagnetic material.

The claims of Groups A, B and C do not share a common inventive concept. The claims must be limited to one invention only as set out in PCT Rule 13.

**INTERNATIONAL SEARCH REPORT**  
Information on patent family members

International application No.  
**PCT/CA2011/000587**

Patent Document Cited in Search Report	Publication Date	Patent Family Member(s)	Publication Date
US2765908A	09 October 1956 (09-10-1956)	None	
US331616A	01 December 1885 (01-12-1885)	None	
CA2125938A1	18 December 1994 (18-12-1994)	CA2125938A1 DE59309909D1 EP0629900A1 EP0629900B1 JP7072604A US5526998A	18 December 1994 (18-12-1994) 27 January 2000 (27-01-2000) 21 December 1994 (21-12-1994) 22 December 1999 (22-12-1999) 17 March 1995 (17-03-1995) 18 June 1996 (18-06-1996)
US3650389A	21 March 1972 (21-03-1972)	None	
US1692789A	20 November 1928 (20-11-1928)	None	
US3555474A	12 January 1971 (12-01-1971)	DE1921544A1 DE1921544B2 ES367702A1 GB1187557A SE355010B	20 November 1969 (20-11-1969) 13 November 1975 (13-11-1975) 16 April 1971 (16-04-1971) 08 April 1970 (08-04-1970) 02 April 1973 (02-04-1973)
WO8304340A1	08 December 1983 (08-12-1983)	EP0110970A1	20 June 1984 (20-06-1984)
CA2439138A1	31 January 2004 (31-01-2004)	CA2439138A1 CA2439138C US2004118966A1 US7070142B2	31 January 2004 (31-01-2004) 19 February 2008 (19-02-2008) 24 June 2004 (24-06-2004) 04 July 2006 (04-07-2006)