

Dec. 6, 1938.

J. C. VIEHMANN
EXTENSION LEAF TABLE

2,139,140

Filed March 4, 1937

2 Sheets-Sheet 1

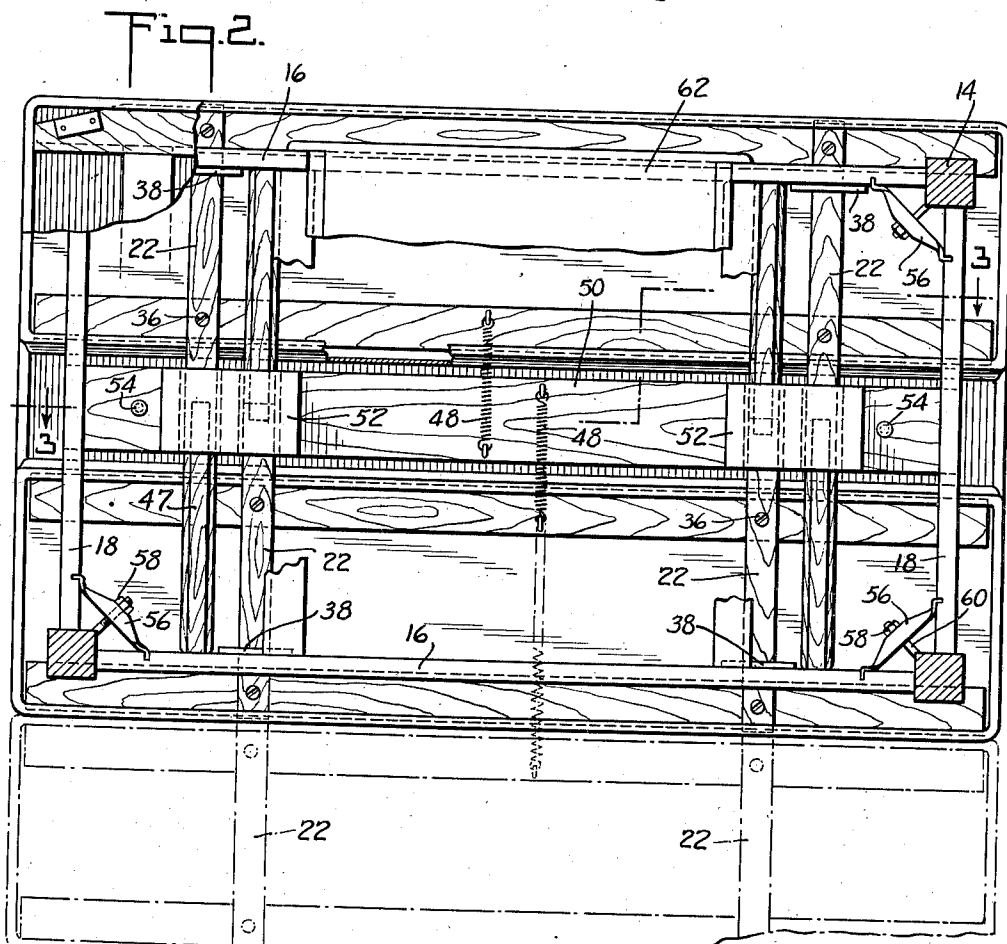
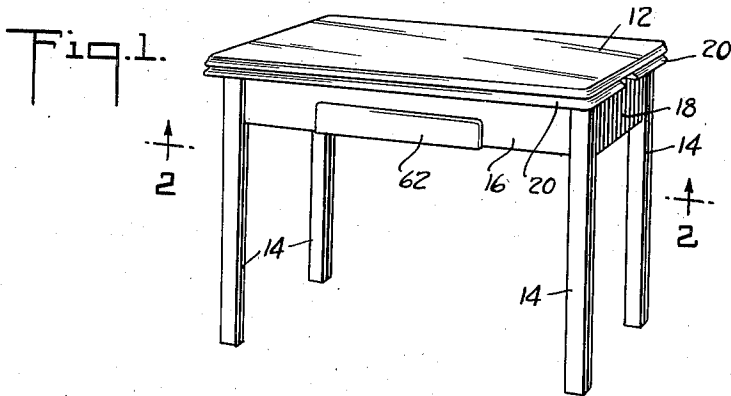

INVENTOR
John C. Viehmann
BY
James & Franklin
ATTORNEYS

Dec. 6, 1938.

J. C. VIEHMANN
EXTENSION LEAF TABLE

2,139,140

Filed March 4, 1937

2 Sheets-Sheet 2

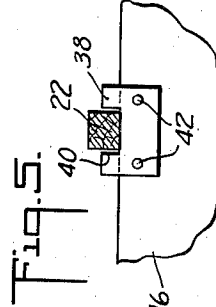
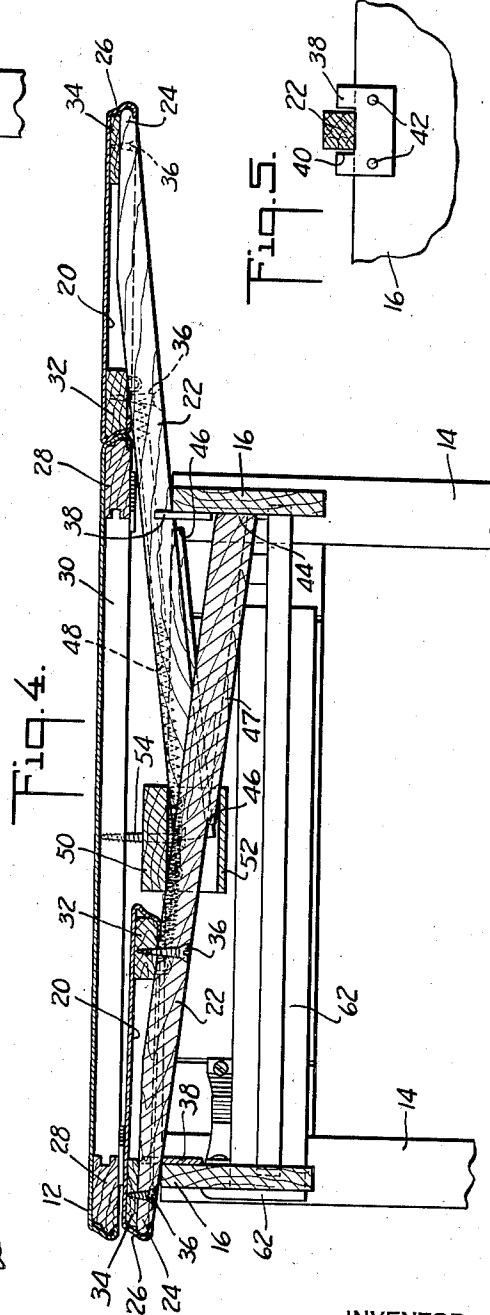
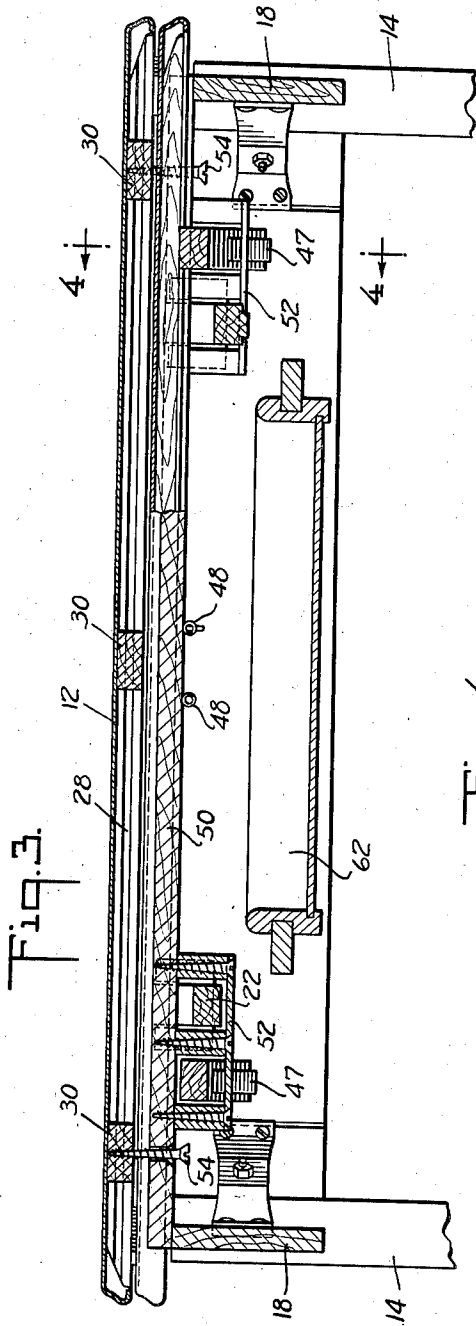

INVENTOR
John C. Viehmann
BY
James & Franklin
ATTORNEYS

UNITED STATES PATENT OFFICE

2,139,140

EXTENSION LEAF TABLE

John C. Viehmann, Flushing, N. Y.

Application March 4, 1937, Serial No. 128,895

4 Claims. (Cl. 311—56)

This invention relates to tables, and more particularly to tables of the extension leaf type.

The primary object of my invention is to generally improve extension leaf tables. These tables as conventionally constructed employ extension leaves adapted to slide from a position beneath the table top to a position alongside the table top. The leaves are supported and guided by so-called slides which extend transversely beneath each leaf and beneath the table top. In accordance with conventional practice, the rails of the table are recessed or cut to receive the slides. The resulting cuts are unsightly and weaken the rails. Moreover, the ends of the slides are visible in the cuts when the leaves are moved to closed position, and inasmuch as it is impossible to provide a high finish on end wood, the appearance of the table is additionally marred by this factor.

Further objects of my invention are to overcome these defects, and to completely eliminate notches or cuts in the rails with their attendant disadvantages, and to conceal the ends of the slides.

To the accomplishment of the foregoing and other more specific objects which will hereinafter appear, my invention consists in the extension leaf table elements and their relation one to the other as hereinafter are more particularly described in the specification and sought to be defined in the claims. The specification is accompanied by drawings in which:

Fig. 1 is a perspective view of an extension leaf table embodying my invention;

Fig. 2 is an inverted plan view taken in the plane of the line 2—2 of Fig. 1;

Fig. 3 is a section taken in elevation in the plane of the line 3—3 of Fig. 2;

Fig. 4 is a transverse section taken in elevation in the plane of the line 4—4 of Fig. 3; and

Fig. 5 is a detail explanatory of the invention.

Referring to the drawings and more particularly to Fig. 1, the table there shown is conventional in comprising a table top 12, legs 14, side rails 16 and end rails 18 extending between the legs, and extension leaves 20 nested beneath the table top between the top and the rails. It will be noted, however, that the rails 16 are devoid of the conventional recesses or cuts at the upper edge thereof, and that no slides for supporting the leaves 20 are visible.

Considering the arrangement in greater detail and referring to the remaining figures of the drawings, particularly Fig. 4, it will be seen that the slides 22 of the leaves 20 are disposed wholly above the upper edges of the rails 16. To accomplish this result without necessitating the provision of an excessive unsightly space between the table top 12 and the rails 16, it will be noted that the outer ends 24 of slides 22 are thinned or tapered. It will also be noted that the ends 24

are disposed in back of and are concealed by the edges 26 of the leaves 20.

In the case here illustrated, the table is of the so-called porcelain type, that is, the table top 12 is made of sheet metal coated with fused vitreous enamel or porcelain, and the same applies to the extension leaves 20. The top 12 is strengthened and rigidified by wood inserts making up a so-called filler frame. In the present case this frame comprises the longitudinal strips 28 (Fig. 4) and the transverse strips 30 (Fig. 3). Similarly, each extension leaf 20 is provided with a filler frame made up of longitudinal strips 32 and 34 disposed respectively at the inner and outer edges of the leaf. The slides 22 act as transverse members for the filler frame, they being secured to the longitudinal strips by appropriate fastening means such as the screws 36.

In accordance with my invention, the outer strips 34 are made comparatively thin. They are to be contrasted, for example, with the inner strips 32 which are of the same thickness as the extension leaf and the table top, all in accordance with prior practice. By greatly reducing the thickness of the outer strips 34 and by limiting the thickness of the slide ends 24 to an amount approximately equal to the reduction in thickness of strips 34, the ends 24 may be received behind and concealed by the outer edge 26 of the extension leaf. In fact, I prefer to go even further in so shaping the slide end that it projects into and interlocks with the leaf edge 26, as will be obvious from inspection of Fig. 4 of the drawings. This strengthens the leaf against upward pull when opening the same. Moreover, the wedging of the end of the slide in interlocked position helps keep the wood parts of the filler frame in rigid relation and prevents the ends of the slides from moving out of alignment toward one side or the other. With the parts kept in fixed rigid relation, the operation of the slides is smooth and there is no possibility of binding.

Instead of using a thin strip 34, it is also possible to employ a thick strip which, however, is recessed or cut away to receive the slide ends 24.

To strengthen the slides 22 while limiting the vertical dimension thereof, I prefer to increase the lateral or horizontal dimension thereof. This will be seen from the proportioning of the slides as shown in section in Fig. 3.

As so far described, the construction would be characterized by the disadvantage of possible movement from side to side of the slides 22 over the upper edge of rails 16. I therefore additionally provide guides 38 for the slides 22. These guides are mounted inside rails 16 and project above the rails. Their construction will be evident from inspection of Fig. 5 which shows one of the guides 38 secured to rail 16. The guide is cut away or recessed at 40 to receive the slide 22. In

the present case the guide is cut out of multiple-wood and is secured to rail 16 by screws 42, but it will be understood that other materials, such as metal, may be used for the guides.

5 The remaining constructional features of the table are largely conventional and will be understood by those skilled in this art, without excessively detailed description. The slides 22 are made such in length that the inner ends 44 abut
10 the opposite rail 16 when the leaf is moved beneath the top, as is illustrated by the left-hand leaf in Fig. 4. The slide 22 is stepped intermediate its length at 46, the resulting shoulder functioning to prevent the leaf from being pulled
15 entirely out of the table when attempting to open the table. Referring to Fig. 4, it will be seen that shoulder 46 is so located that the leaf may be drawn outwardly somewhat further than the position shown, and then moved up over the edge of
20 the table top. The leaf is normally drawn inwardly by a pull spring 48 secured at its outer end to filler strip 32 and secured at its inner end to a center board 50 which extends between and is secured to the end rails 18. To economize in the
25 use of material, the shoulder 46 is preferably formed at one end of an extra strip 47 which is added beneath the slide 22.

The inner ends of slides 22 are guided by appropriate housings 52 the nature and construction of which will be evident from inspection of
30 Figs. 2, 3, and 4 of the drawings. These housings are mounted beneath and secured to the center board 50 previously referred to. The manner in which the slides of the opposite leaves are staggered or displaced sidewardly from one another
35 will be evident from inspection of Figs. 2 and 3, while the relation of the slides to housing 52 when the extension leaf is closed or opened, will be evident from inspection of Fig. 4.

40 In the present case the table top is of the floating type, that is, it is capable of a slight upward or downward movement during change in position of the extension leaves. For this purpose the table top is located in position by screws 54 (Fig.
45 3) which pass through oversized openings in the center board 50 and which are adequate in length to afford a slight upward movement of the table top relative to the rest of the table.

The legs 14 are of the detachable type, and for this reason the rails 16 and 18 are joined together
50 by special metal fittings 56. When the legs 14 are applied to the corners of the table, they are locked in place by simply adding and tightening the nuts 58, the bolts 60 forming a part of the legs. The
55 drawer 62 is optional and may be made in accordance with conventional practice.

It is believed that the construction and operation of my improved extension leaf table, as well as the many advantages thereof, will be apparent
60 from the foregoing detailed description. The rails are devoid of unsightly cuts and are strengthened by their absence. The ends of the slides are not exposed and there is no problem of attempting to finish the end wood of the slides. Nevertheless
65 the extension leaves may be operated smoothly and readily, and are strongly supported in position. These desirable improvements are obtained without greatly modifying or appreciably increasing the expense of manufacture of the table. The
70 ends of the slides are tapered to small dimension and are not only concealed by the edge of the leaf

but are interlocked with the edge to strengthen the structure against upward pull on the leaf when opening the same.

It will be understood that while I have illustrated a table with front and back leaves, the invention may also be applied to a refectory table with end leaves.

It will therefore be apparent that while I have shown and described my invention in a preferred form, many changes and modifications may be made in the structure disclosed, without departing from the spirit of the invention, defined in the following claims.

I claim:

1. An extension leaf table comprising a table top, rails therebeneath and spaced therefrom to receive extension leaves, slides extending transversely of each leaf beneath the table top, said slides being disposed above the rails, the outer ends of said slides extending substantially as far as the outer edges of the leaves and being reduced to a comparatively small dimension in a vertical direction and being concealed behind the outer edge of the leaf.

2. An extension leaf table comprising a table top, a rail therebeneath and spaced therefrom to receive an extension leaf, said extension leaf being made of porcelain-coated sheet metal turned downwardly at its peripheral edge, a filler frame inserted in said leaf, said frame including a strip of wood at the inner edge and a strip of wood at the outer edge of the leaf, slides extending transversely of the leaf beneath the table top, said slides being secured to each of the aforesaid strips of the filler frame, and the outer ends of said slides being small in a vertical direction to form a thin end which comes within and is concealed by the outer edge of the leaf.

3. An extension leaf table comprising a table top, rails therebeneath and spaced therefrom to receive extension leaves, said extension leaves being made of porcelain-coated sheet metal turned downwardly at the peripheral edge, a filler frame inserted in each of said leaves, said frame including a thick strip of wood at the inner edge of each leaf and a thin strip of wood at the outer edge of each leaf, slides extending transversely beneath each leaf, said slides being secured to the aforesaid strips of the filler frame, and the outer ends of said slides being reduced in a vertical direction to form a comparatively thin end which comes within and is concealed by the outer edge of the leaf.

4. An extension leaf table comprising a table top, rails therebeneath and spaced therefrom to receive extension leaves, said extension leaves being made of porcelain-coated sheet metal turned downwardly at the peripheral edge, a filler frame inserted in each of said leaves, said frame including a thick strip of wood at the inner edge of each leaf, and a thin strip of wood at the outer edge of each leaf, slides extending transversely beneath each leaf, said slides being secured to the aforesaid strips of the filler frame, the outer end of each slide being reduced in a vertical direction to form a comparatively thin end which comes within the outer edge of the leaf, said slides being disposed above the rails and said rails being devoid of notches or cuts for receiving the slides.

JOHN C. VIEHMANN.