



(43) International Publication Date
21 September 2023 (21.09.2023)

(51) International Patent Classification:

A61C 8/00 (2006.01) A61C 3/02 (2006.01)
A61B 17/16 (2006.01)

(21) International Application Number:

PCT/TR2022/051225

(22) International Filing Date:

02 November 2022 (02.11.2022)

(25) Filing Language:

English

(26) Publication Language:

English

(30) Priority Data:

2022/014970 29 September 2022 (29.09.2022) TR

(71) Applicant: **BVK TEKNOLOJİ ANONİM ŞİRKETİ**
[TR/TR]; Resitpasa Mah. Katar Cad. Ari 6 Sitesi Enerji
Teknokenti No:2/49/103-104, 34467 Sariyer/Istanbul (TR).

(72) Inventor; and

(71) Applicant: **BAYSAL, Cem** [TR/TR]; Hacı Emin Efendi
Sokak 64/8 Tesvikiye, Sisli/Istanbul (TR).

(74) Agent: **CANKAYA PATENT MARKA VE DANIS-
MANLIK LIMITED SİRKETİ**; Remzi Oguz Arik Mah.
Bestekar Cad. Bestekar Is Merkezi No:49/19, 06680
Cankaya/Ankara (TR).

(81) Designated States (unless otherwise indicated, for every
kind of national protection available): AE, AG, AL, AM,
AO, AT, AU, AZ, BA, BB, BG, BH, BN, BR, BW, BY, BZ,
CA, CH, CL, CN, CO, CR, CU, CV, CZ, DE, DJ, DK, DM,
DO, DZ, EC, EE, EG, ES, FI, GB, GD, GE, GH, GM, GT,
HN, HR, HU, ID, IL, IN, IQ, IR, IS, IT, JM, JO, JP, KE,
KG, KH, KN, KP, KR, KW, KZ, LA, LC, LK, LR, LS, LU,
LY, MA, MD, MG, MK, MN, MW, MX, MY, MZ, NA, NG,
NI, NO, NZ, OM, PA, PE, PG, PH, PL, PT, QA, RO, RS,
RU, RW, SA, SC, SD, SE, SG, SK, SL, ST, SV, SY, TH,

TJ, TM, TN, TR, TT, TZ, UA, UG, US, UZ, VC, VN, WS,
ZA, ZM, ZW.

(84) Designated States (unless otherwise indicated, for every
kind of regional protection available): ARIPO (BW, CV,
GH, GM, KE, LR, LS, MW, MZ, NA, RW, SC, SD, SL, ST,
SZ, TZ, UG, ZM, ZW), Eurasian (AM, AZ, BY, KG, KZ,
RU, TJ, TM), European (AL, AT, BE, BG, CH, CY, CZ,
DE, DK, EE, ES, FI, FR, GB, GR, HR, HU, IE, IS, IT, LT,
LU, LV, MC, ME, MK, MT, NL, NO, PL, PT, RO, RS, SE,
SI, SK, SM, TR), OAPI (BF, BJ, CF, CG, CI, CM, GA, GN,
GQ, GW, KM, ML, MR, NE, SN, TD, TG).

Published:

- with international search report (Art. 21(3))
- before the expiration of the time limit for amending the
claims and to be republished in the event of receipt of
amendments (Rule 48.2(h))
- upon request of the applicant, before the expiration of the
time limit referred to in Article 21(2)(a)
- in black and white; the international application as filed
contained color or greyscale and is available for download
from PATENTSCOPE

(54) Title: CRESTAL APPROACH MAXILLARY SINUS LIFTING OSTEOTOME APPARATUS

Figure 1

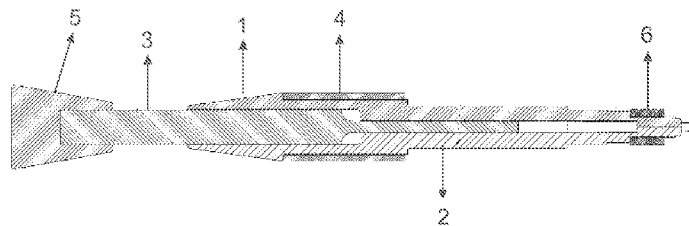

(57) Abstract: The invention relates to an osteotome apparatus used in the surgical sinus floor lifting in order to increase the bone amount in the absence of sufficient bone in the area to be implanted.



CRESTAL APPROACH MAXILLARY SINUS LIFTING OSTEOTOME APPARATUS

5

Technical Field

The invention relates to an osteotome apparatus used in the surgical sinus floor lifting in order to increase the bone amount in the absence of sufficient bone in the area to be implanted.

10

Background

When implantation is required in the upper jaw, if there is not enough bone, a procedure called sinus lifting or sinus elevation is applied, and the sinus floor is surgically lifted and a bone powder/grafting process is performed. During this process, an apparatus called osteotome is used. The sinus lifting process can be performed with two methods as lateral antrostomy and crestal approach. This study relates to an apparatus that can be used in the crestal approach technique.

20 There is a risk of damaging the Schneider membrane (sinus membrane) in maxillary sinus lifting operations.

The Korean patent document numbered KR20200118553A, which is in the state of the art, discloses a milling tool comprising an implant-guided stopper that has the stop height function and controls the depth. It includes the height-stopping member. A predetermined depth can be adjusted to the guide portion.

The International patent document numbered WO2008125449A1, which is in the state of the art, discloses a surgical bone drilling tool. There is a handle to transmit the pressure to the milling head. The bone-cutting process includes a sharply elevated milling ridge that serves as a blade. It includes a body called the milling element that enters inside the bone.

The International patent document numbered WO2009136775A2, which is in the state of the art relates to a pressure sensitive drill that can prevent damage to the mucosa by drill when the

implant is placed on the maxillary sinus elevation. It includes the elevating blade portion, the cutting blade portion, and the base portion.

5 The International patent document numbered WO2017035872A1, which is in the state of the art discloses a memory elastic wire sheath for peeling the mucous membrane of the maxillary sinus, adapted for implant surgeries and/or bone grafting in areas close to the maxillary sinus floor.

10 During the sinus lifting process, firstly, an osteotome apparatus is placed in the bone cavity opened with a drill, and then the sinus lifting process is performed using a hammer. The osteotome apparatuses in the state of the art cannot perform the sinus lifting process to provide the bone volume required for the attachment of the implant in jaw bone deficiencies. If enough bone is not formed, it will have disadvantages in the durability and lifetime of the implant. In addition, while performing this process, there are risks such as perforation of the sinus
15 membrane in case of excessive insertion of the osteotome apparatus into the cavity within the bone.

There is no osteotome apparatus in the documents in the state of the art that provides sufficient bone formation and prevents damage to the sinus membrane. Therefore, there was a need to
20 develop the crestal approach maxillary sinus lifting osteotome apparatus of the invention.

The Objects of the Invention

25 The object of this invention is to realize the crestal approach maxillary sinus lifting osteotome apparatus to perform the lifting process without damaging the sinus membrane in maxillary sinus lifting processes.

Another object of this invention is to realize the crestal approach maxillary sinus lifting osteotome apparatus to perform a wider drilling process on the surface by opening outwards
30 while the lifting blade advances within the jaw bone with hammer impacts and to obtain more bone volume.

Another object of this invention is to realize the crestal approach maxillary sinus lifting osteotome apparatus, which includes a ring to prevent the lifting blade from advancing beyond a certain level.

- 5 Another object of this invention is to realize the crestal approach maxillary sinus lifting osteotome apparatus, which includes level settings to prevent the lifting blade from advancing beyond a certain level.

10 Another object of this invention is to realize the crestal approach maxillary sinus lifting osteotome apparatus to perform the process without graft and allow natural bone formation.

Another object of this invention is to realize the crestal approach maxillary sinus lifting osteotome apparatus to eliminate the damage of the graft to the patient by performing the process without graft.

15

Another object of this invention is to realize the crestal approach maxillary sinus lifting osteotome apparatus to perform the process with less cost by performing the process without graft.

20 **Detailed Description of the Invention**

The crestal approach maxillary sinus lifting osteotome apparatus realized to achieve the objects of this invention is shown in the attached figures.

25 In which;

Figure 1: The schematic view of the crestal approach maxillary sinus lifting osteotome apparatus.

30 **Figure 2:** The exploded view of the crestal approach maxillary sinus lifting osteotome apparatus.

Figure 3: The view showing that the lifting blade is located in level line I of the apparatus of the invention before starting the operation.

Figure 4: The view showing that the lifting blade reaches its final state at level line II of the apparatus of the invention after starting the operation.

5 **Figure 5:** The view when the lifting blade of the apparatus opens and enters into the maxilla alveolar bone during the operation.

The parts in the figures are numbered individually and the equivalents of these numbers are given below.

10

1. Upper part
2. Lower part
3. Lifting blade
4. Clamping collar

15

5. Handle
6. Ring
7. Level line I
8. Level line II
9. Maxilla alveolar bone

20

10. Sinus membrane

The invention relates to the crestal approach maxillary sinus lifting osteotome apparatus, comprising

25

– the lower part (2), which has a cavity and thus prevents damage to the sinus membrane (10),

– the lifting blade (3), which is located between the upper part (1) and the lower part (2) and provides the forward movement within the maxilla alveolar bone (9) in a controlled manner at a certain depth due to its bearing in the cavity in the lower part (2),

30

– the clamping collar (4) which fixes the lifting blade (3) by surrounding the upper part (1) and the lower part (2) after the lifting blade (3) is placed between the upper part (1) and the lower part (2),

- the handle (5) which is connected to the lifting blade (3) and allows the lifting blade (3) to move within the bone by applying impacts by the hammer,
- the ring (6) which is located at the head part of the upper part (1) and the lower part (2) of the body and prevents the apparatus from entering the hole drilled in the maxilla alveolar bone (9).

5

In the osteotome apparatus, all parts of which are made of non-harmful surgical stainless steel, the lifting blade (3) is in the back position when the apparatus is first placed in the maxilla alveolar bone (9) cavity drilled in the jaw. The position of the osteotome apparatus placed on the maxilla alveolar bone (9) is determined by the ring (6) and it is prevented from moving further. The clamping collar (4) around the upper part (1) and the lower part (2) of the body keeps the divided parts of the apparatus together and helps to compress. Thus, the lifting blade (3) is centered between the two outer bodies. An impact is applied by the hammer to the handle (5) mounted on the moving lifting blade (3) and the lifting blade (3) moves forward within the maxilla alveolar bone (9).

10

15

The dentist determines the position to place the apparatus by using the patient's film obtained by imaging. There are level lines on the lifting blade (3), which moves forward within the maxilla alveolar bone (9) with hammer impacts, to adjust the position and not damage the sinus membrane (10).

20

The developed sinus lifting osteotome apparatus is a mechanical osteotome apparatus used in sinus lifting surgical operations. The developed osteotome apparatus has a design to enable a wider drilling process on the surface. During the sinus lifting process, while the lifting blade (3), which is placed between the upper part (1) and the lower part (2), moves forward within the maxilla alveolar bone (9) with the hammer impacts applied to the handle (5), the lifting blade (3) opens outwards and the wider drilling process is performed on a surface. There are 2 level lines on the lifting blade (3), level line I (7), and level line II (8). The indicated level lines can show the depth of the hole drilled in the maxilla alveolar bone (9). The ring (6) prevents excessive insertion into the hole drilled in the maxilla alveolar bone (9), and thus prevents damage to the sinus membrane (10). There is a cavity in the section on the lower part (2) where the lifting blade (3) is placed. Before starting the operation, while the lifting blade (3) is located in the center of this cavity, level line I (7) is aligned with the end of the lower part (2), as seen in Figure 3. When an impact is applied by the hammer to the handle (5), the lifting blade (3)

25

30

moves forward in a limited amount over the cavity on the lower part (2). The level line II (8) on the lifting blade (3) becomes aligned with the end of the lower part (2), as seen in Figure 4. With a precaution taken inside the osteotome apparatus, the lifting blade (3) cannot move further. The end of the lifting blade (3) made of heat-treated stainless steel fits the form of the outer body parts and stretches outward and provides a larger diameter drilling in the maxilla alveolar bone (9).

The advantages obtained with the developed osteotome apparatus are listed below.

- 10 – It provides the lifting process without damaging the sinus membrane (10) in the maxillary sinus lifting processes.
- While the lifting blade (3) moves forward within the maxilla alveolar bone (9) with the hammer impacts, it opens outwards and allows a wider drilling process on the surface and more bone volume.
- 15 – The risk of damaging the sinus membrane (10) is prevented by preventing the lifting blade (3) from moving beyond a certain level since it includes a ring (6).
- As it includes the level settings, the lifting blade (3) is prevented from moving beyond a certain level.
- It allows the process to be performed without grafts and the bone to be formed naturally.
- 20 – The damage caused by the graft to the patient was eliminated by performing the process without grafts.
- A less costly method is provided by performing the process without grafts.

CLAIMS

1. The crestal approach maxillary sinus lifting osteotome apparatus, **characterized in that** it comprises
- 5
- the lower part (2), which has a cavity and thus prevents damage to the sinus membrane (10),
 - the lifting blade (3), which is located between the upper part (1) and the lower part (2) and provides the forward movement within the maxilla alveolar bone (9) in a controlled

10

 - the clamping collar (4) which fixes the lifting blade (3) by surrounding the upper part (1) and the lower part (2) after the lifting blade (3) is placed between the upper part (1) and the lower part (2),
 - the ring (6) which is located at the head part of the upper part (1) and the lower part (2)

15

 - of the body and prevents the apparatus from entering the hole drilled in the maxilla alveolar bone (9).
2. An osteotome apparatus according to claim 1, **characterized in that** it comprises the handle (5) which is connected to the lifting blade (3) and allows the lifting blade (3) to
- 20
- move within the maxilla alveolar bone (9) by applying impacts by hammer.
3. An osteotome apparatus according to claim 1, **characterized in that** it comprises level line I (7) and level line II (8) on the lifting blade (3).

25

Figure 1

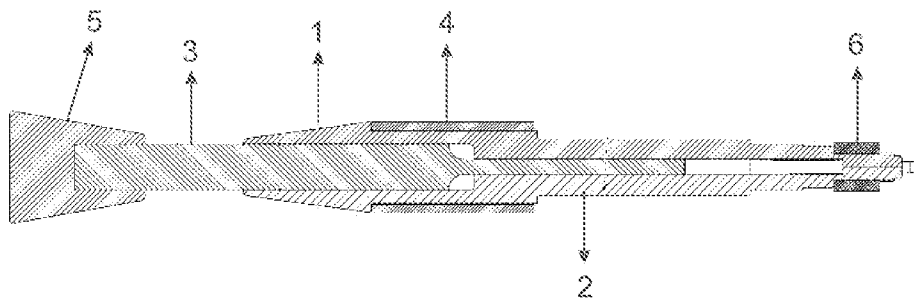

Figure 2

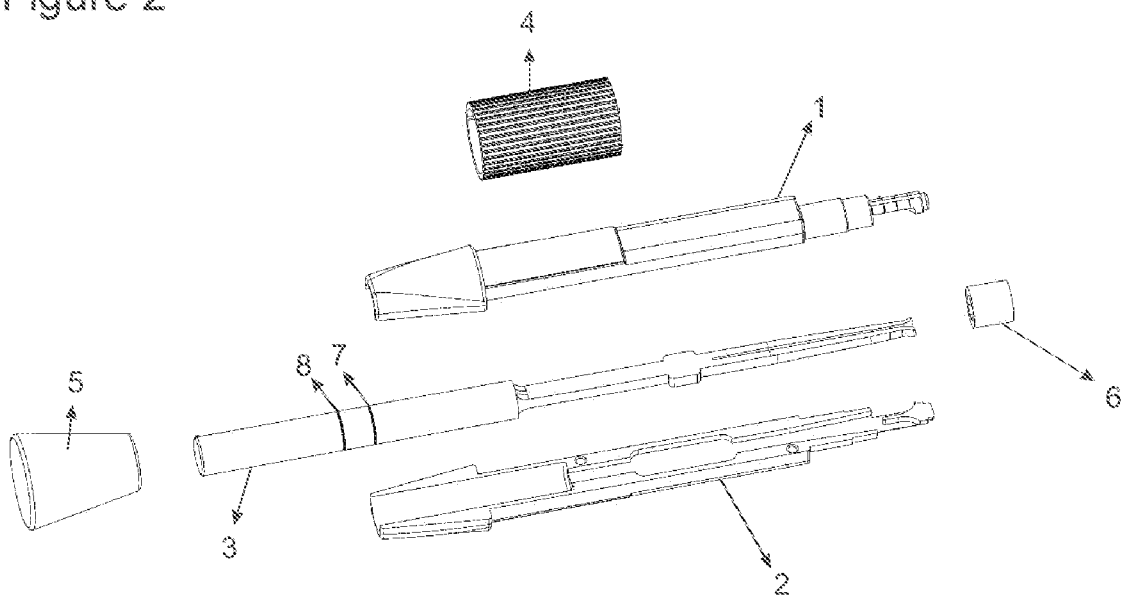

Figure 3

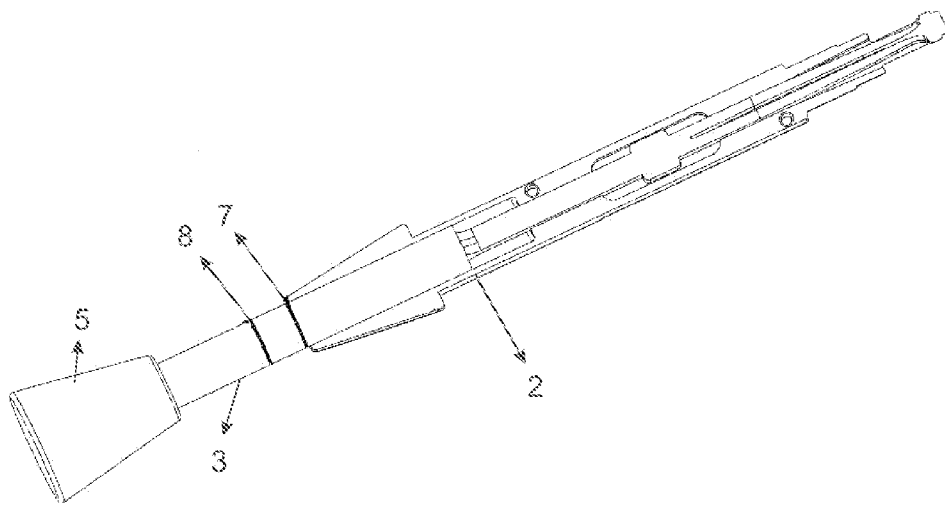

Figure 4

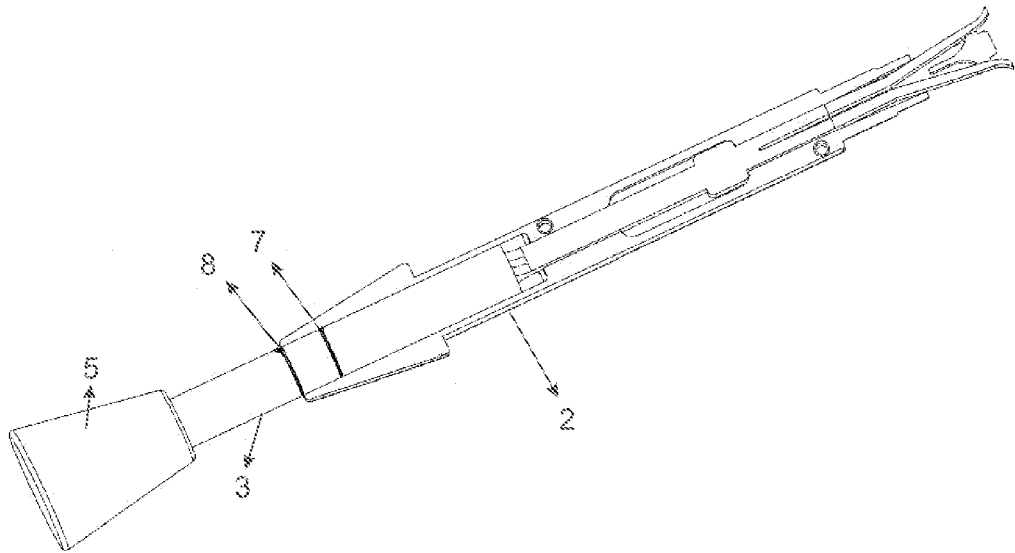
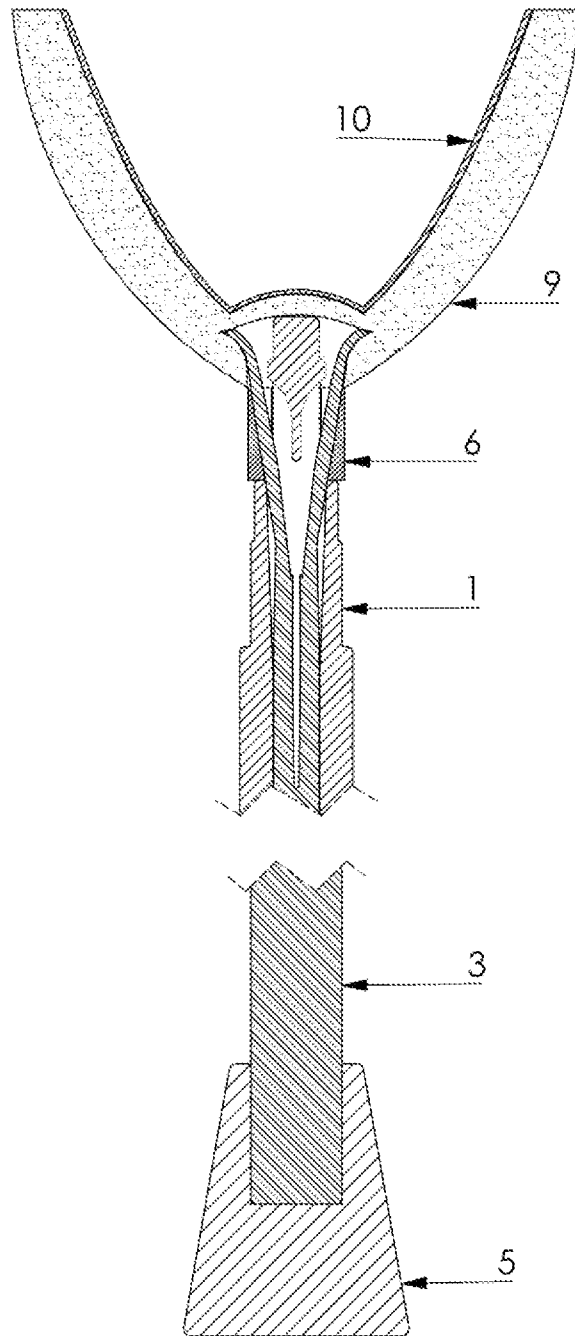

Figure 5



INTERNATIONAL SEARCH REPORT

International application No.

PCT/TR2022/051225

A. CLASSIFICATION OF SUBJECT MATTER		
A61C 8/00 (2006.01)i; A61B 17/16 (2006.01)i; A61C 3/02 (2006.01)i A61C 8/0089, A61C 8/0092, A61B 17/1688 CPC		
According to International Patent Classification (IPC) or to both national classification and IPC		
B. FIELDS SEARCHED		
Minimum documentation searched (classification system followed by classification symbols) A61C; A61B A61C 8/0089, A61C 8/0092, A61B 17/1688 CPC		
Documentation searched other than minimum documentation to the extent that such documents are included in the fields searched		
Electronic data base consulted during the international search (name of data base and, where practicable, search terms used) EPODOC, patenw, MedicalExpo, Google Patents, Turkish National Patent Database, Keywords: osteotome, sinus lift, crestal, anrostomy, bone cut, maxillary, blade, cavity, opening, level, stage, depth mark, ring, collar, clamp, handle		
C. DOCUMENTS CONSIDERED TO BE RELEVANT		
Category*	Citation of document, with indication, where appropriate, of the relevant passages	Relevant to claim No.
A	US 2010266984 A1 (JUNG SUNG MIN [KR]) 21 October 2010 (2010-10-21) abstract, paragraphs [0010], [0015]-[0022], [0035]-[0045]	1-3
A	US 6171312 B1 (IMPLANT INNOVATIONS INC [US]) 09 January 2001 (2001-01-09) abstract, column 2 lines 37-50, column 3 lines 1-23, column 4 lines 29-36, column 5 lines 12-29, column 6 line 33-column 9 line 4, column 11 lines 38-60	1-3
A	US 2006172255 A1 (ACE SURGICAL SUPPLY CO, INC) 03 August 2006 (2006-08-03) Whole document	1-3
A	US 2014038126 A1 (KRASTEV PAVEL [US]) 06 February 2014 (2014-02-06) abstract, paragraphs [0002], [0005]-[0008], [0074]-[0075], [0083]-[0084], [0090], [0095], [0100]-[0103]	1-3
D,A	WO 2008125449 A1 (CGM SPA [IT]; PARMIGIANI CORRADO SAVERIO [IT]) 23 October 2008 (2008-10-23) Whole document	1-3
<input checked="" type="checkbox"/> Further documents are listed in the continuation of Box C. <input checked="" type="checkbox"/> See patent family annex.		
* Special categories of cited documents: "A" document defining the general state of the art which is not considered to be of particular relevance "D" document cited by the applicant in the international application "E" earlier application or patent but published on or after the international filing date "L" document which may throw doubts on priority claim(s) or which is cited to establish the publication date of another citation or other special reason (as specified) "O" document referring to an oral disclosure, use, exhibition or other means "P" document published prior to the international filing date but later than the priority date claimed "T" later document published after the international filing date or priority date and not in conflict with the application but cited to understand the principle or theory underlying the invention "X" document of particular relevance; the claimed invention cannot be considered novel or cannot be considered to involve an inventive step when the document is taken alone "Y" document of particular relevance; the claimed invention cannot be considered to involve an inventive step when the document is combined with one or more other such documents, such combination being obvious to a person skilled in the art "&" document member of the same patent family		
Date of the actual completion of the international search 10 June 2023		Date of mailing of the international search report 10 June 2023
Name and mailing address of the ISA/TR Turkish Patent and Trademark Office (Turkpatent) Hipodrom Caddesi No. 13 06560 Yenimahalle Ankara Türkiye Telephone No. +903123031000 Facsimile No. +903123031220		Authorized officer Ceren BORA ORÇUN Telephone No. +903123031620

INTERNATIONAL SEARCH REPORT

International application No.

PCT/TR2022/051225

C. DOCUMENTS CONSIDERED TO BE RELEVANT		
Category*	Citation of document, with indication, where appropriate, of the relevant passages	Relevant to claim No.
A	ES 1287694 U (FERNANDEZ CASTELLANO ERICK RAFAEL [ES]) 08 March 2022 (2022-03-08) Whole document	1-3
A	US 2016074140 A1 (FRONCARE [US]) 17 March 2016 (2016-03-17) abstract, paragraphs [0002]-[0008], [0039]-[0058]	1-3

INTERNATIONAL SEARCH REPORT
Information on patent family members

International application No.

PCT/TR2022/051225

Patent document cited in search report			Publication date (day/month/year)	Patent family member(s)			Publication date (day/month/year)
US	2010266984	A1	21 October 2010	KR	20100115188	A	27 October 2010
				KR	101112777	B1	14 March 2012
US	6171312	B1	09 January 2001	AT	260072	T	15 March 2004
				AU	3669497	A	10 February 1998
				DE	69727816	D1	01 April 2004
				DE	69727816	T2	05 August 2004
				EP	0925033	A1	30 June 1999
				EP	0925033	A4	19 June 2002
				EP	0925033	B1	25 February 2004
				ES	2216160	T3	16 October 2004
				US	6899715	B1	31 May 2005
				WO	9803119	A1	29 January 1998
US	2006172255	A1	03 August 2006	US	7771199	B2	10 August 2010
US	2014038126	A1	06 February 2014	US	9795467	B2	24 October 2017
				US	2018098834	A1	12 April 2018
				US	10258444	B2	16 April 2019
WO	2008125449	A1	23 October 2008	NONE			
ES	1287694	U	08 March 2022	ES	1287694	Y	27 May 2022
US	2016074140	A1	17 March 2016	US	9757215	B2	12 September 2017