

(No Model.)

A. J. COURTNEY. CLAMP.

No. 523,974.

Patented Aug. 7, 1894.

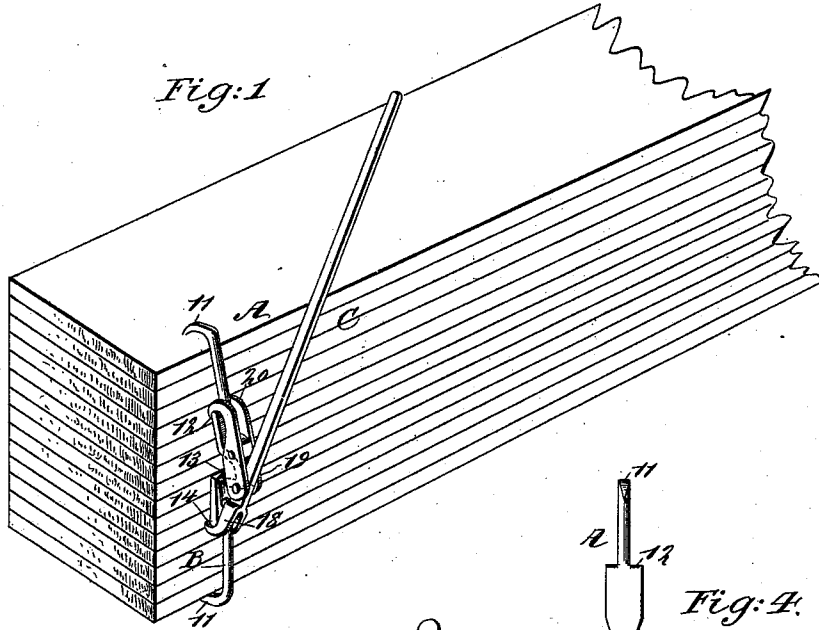

Fig: 1

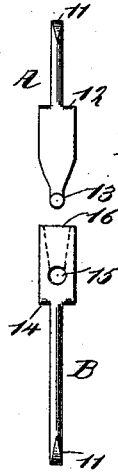

Fig: 4.

Fig: 2.

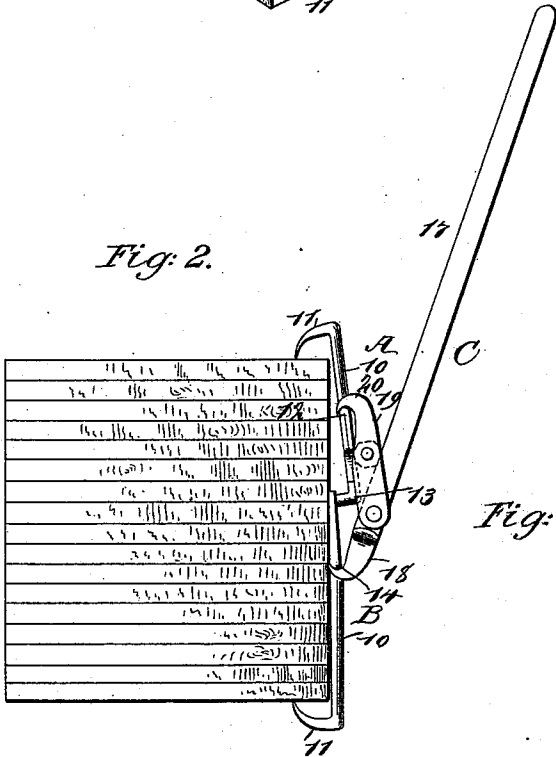
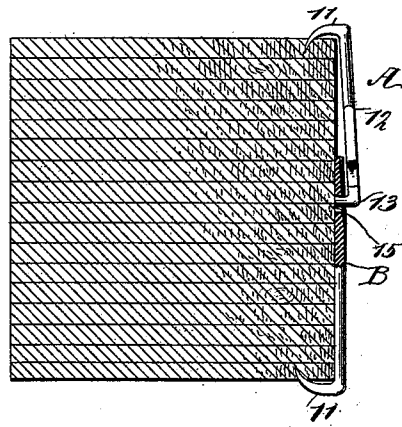

Fig: 3.



WITNESSES:

John A. Kennie
E. M. Clark

INVENTOR

Andrew J. Courtney
BY *Munn & Co*

ATTORNEYS.

UNITED STATES PATENT OFFICE.

ANDREW J. COURTNEY, OF PINE RIDGE, CALIFORNIA.

CLAMP.

SPECIFICATION forming part of Letters Patent No. 523,974, dated August 7, 1894.

Application filed July 25, 1893. Serial No. 481,394. (No model.)

To all whom it may concern:

Be it known that I, ANDREW J. COURTNEY, of Pine Ridge, in the county of Fresno and State of California, have invented a new and useful Improvement in Clamps, of which the following is a full, clear, and exact description.

My invention relates to an improvement in clamps, and has for its object especially to provide a clamp adapted for bundling and maintaining in bundled form timber of any description, whereby timber may be handled much more expeditiously and economically than it is possible when each piece of timber is independent of the other, and whereby also in shipping timber, jams are not so liable to occur.

The invention consists in the novel construction and combination of the several parts as will be hereinafter fully set forth, and pointed out in the claims.

Reference is to be had to the accompanying drawings, forming a part of this specification, in which similar figures and letters of reference indicate corresponding parts in all the views.

Figure 1 is a perspective view of the device, showing it in the act of being applied. Fig. 2 is a side elevation of the device in the position shown in Fig. 1. Fig. 3 is a partial side elevation and partial sectional view of the device, illustrating it in its applied or clamping position; and Fig. 4 is an inner face view of the device proper.

In carrying out the invention the clamp proper comprises two sections A and B, in connection with which a lever C is employed, the two parts constituting essentially the entire device. The sections A and B of the main or body portion of the device consist each of a bar 10, which at one end terminates in a hook 11; and the inner end of the section A, is provided with a shoulder 12 near its inner end, which shoulder extends beyond opposite faces of the rod or bar 10; and at the extremity of the section A a stud 13, is formed, which stands at right angles to the rod and faces inwardly or in the same direction as the hook 11. The body rod 10 of the other section B, is provided with a shoulder 14, near

its inner end, corresponding to the shoulder 12 of the section A; and the body rod of the section B, continues of the same width from the shoulder to its inner end, and in the wider portion of the section, between the inner end and the shoulder 14, an aperture 15, is produced, adapted to receive the stud 13 of the section A, and a channel or recess 16, is produced in the wider portion of the section B, upon its outer face and extends from its inner end to the aperture 15.

The lever C, comprises a handle member 17, which at one end is bifurcated to form twin claws 18; and near the twin claws 18 of the handle member an arm 19, is pivoted at one end to the said member of the lever, and the outer or free end of this arm is bifurcated and provided with twin claws 20, adapted to face those upon the handle member of the lever, as shown in both Figs. 1 and 2.

In operation, the device may be applied to the sides of a bundle or pile of timber, or to the ends, or to both the sides and ends; and in making the application the hook of one section of the main portion of the device is made to engage with the outer surface of the top board of a pile, while the hook of the other section engages with the under face of the undermost board. When so engaging the stud 13 of the section A will or should rest upon the channeled surface 16 of the section B. The lever is now applied, the claws 20 of the arms 19, for example, being made to engage with the shoulder 12 of the section A, while the claws 18 of the handle member of the lever will be brought in engagement with the shoulder 14 of the section B. By pressing downward upon the handle of the lever the two sections A and B, will be carried at their inner ends in direction of each other, their hook members sinking into the surfaces with which they contact; and when the two sections have been brought together a sufficient distance to cause the stud 13 of the section A to enter the aperture 15 of the section B, the two sections will be in locking engagement, and will serve to hold the timber constituting the proposed pile in firm and binding engagement, as shown in Fig. 3, and when such locking engagement is effected the

lever C is removed and is applied to other sections to place them likewise in position.

The clamp is exceedingly simple, it is durable and it is economic, and it is capable of being readily manipulated by any person of ordinary intelligence.

Having thus described my invention, I claim as new and desire to secure by Letters Patent—

1. In a lumber clamp consisting of two sections, the combination, with one section comprising a broad body, a clamping hook integral with one end of said body near the center thereof, whereby a shoulder is formed at each side of the hook, and a stud projected at an angle from the opposite end of the body, facing in direction of the curved portion of the hook, of a second member comprising a broad body having a channel produced in one face, and an aperture at the inner end of the channel, a hook the shank of which constitutes an integral portion of the body near the center, forming thereby a shoulder at each side of the shank, the hooks of the two sections being adapted to face in the same direction and face one another, the stud of one section being adapted to enter the aperture of the other section guided thereto by the said channel, substantially as shown and described.

2. In a lumber clamp, the combination, with

the clamp consisting of two sections, one section comprising a broad body, the hook or shank of which is integral with the body at one end, shoulders being formed at the intersection of the shank with the body, the opposite end of the body terminating in a stud at an angle thereto and facing in direction of the hook, the second section comprising a broad body provided with an aperture and a guide leading to the aperture, and a hook the shank of which is integral with one end of the body, a shoulder being formed at each side of the hook shank, the said two sections being adapted to stand body to body, the hooks facing in the same direction and facing each other, of a compression device, the same consisting of a lever terminating at one end in a claw adapted for engagement with the shouldered portion of one section of the clamp, and an arm pivoted to the lever, said arm terminating in a claw adapted for engagement with the shouldered portion of the other clamping section, whereby when the lever is moved in one direction the clamping sections are drawn together, and the stud of one section is made to enter the aperture in the other section, as and for the purpose set forth.

ANDREW J. COURTNEY.

Witnesses:

O. J. LUNDY,
S. L. HOGUE.