



US00D345985S

United States Patent [19]

[11] Patent Number: **Des. 345,985**

Ishikawa et al.

[45] Date of Patent: **** Apr. 12, 1994**

[54] CUTTER INSERT

OTHER PUBLICATIONS

[75] Inventors: **Youichi Ishikawa; Osamu Ichinoseki,**
both of Ibaraki, Japan

Applied Machinery Engineering, No. 272, Nov. 1982, p. 111.

Mitsubishi Metal Corporation, "Mitsubishi Carbide Turning System", CE002, 7.89.N(8B).

[73] Assignee: **Mitsubishi Materials Corporation,**
Tokyo, Japan

Primary Examiner—Alan P. Douglas
Assistant Examiner—Antoine D. Davis
Attorney, Agent, or Firm—Cushman, Darby & Cushman

[**] Term: **14 Years**

[57] CLAIM

The ornamental design for a cutter insert, as shown and described.

[21] Appl. No.: **869,150**

DESCRIPTION

[22] Filed: **Apr. 14, 1992**

FIG. 1 is a perspective view of a cutter insert showing our new design;

[52] U.S. Cl. **D15/139**

FIG. 2 is a front elevation view thereof;

[58] Field of Search 407/110-114;

FIG. 3 is a rear elevation view thereof;

D15/138, 139

FIG. 4 is a right side elevation view thereof;

FIG. 5 is a left side elevation view thereof;

FIG. 6 is a top plan view thereof;

FIG. 7 is a bottom view thereof;

FIG. 8 is a cross-sectional view taken along line 8—8 in

FIG. 2; and,

FIG. 9 is a cross-sectional view taken along line 9—9 in

FIG. 2.

[56] References Cited

U.S. PATENT DOCUMENTS

D. 311,010 10/1990 Niebauer D15/139

4,561,809 12/1985 Porat et al. D15/139 X

4,808,045 2/1989 Tsujimura et al. 408/204

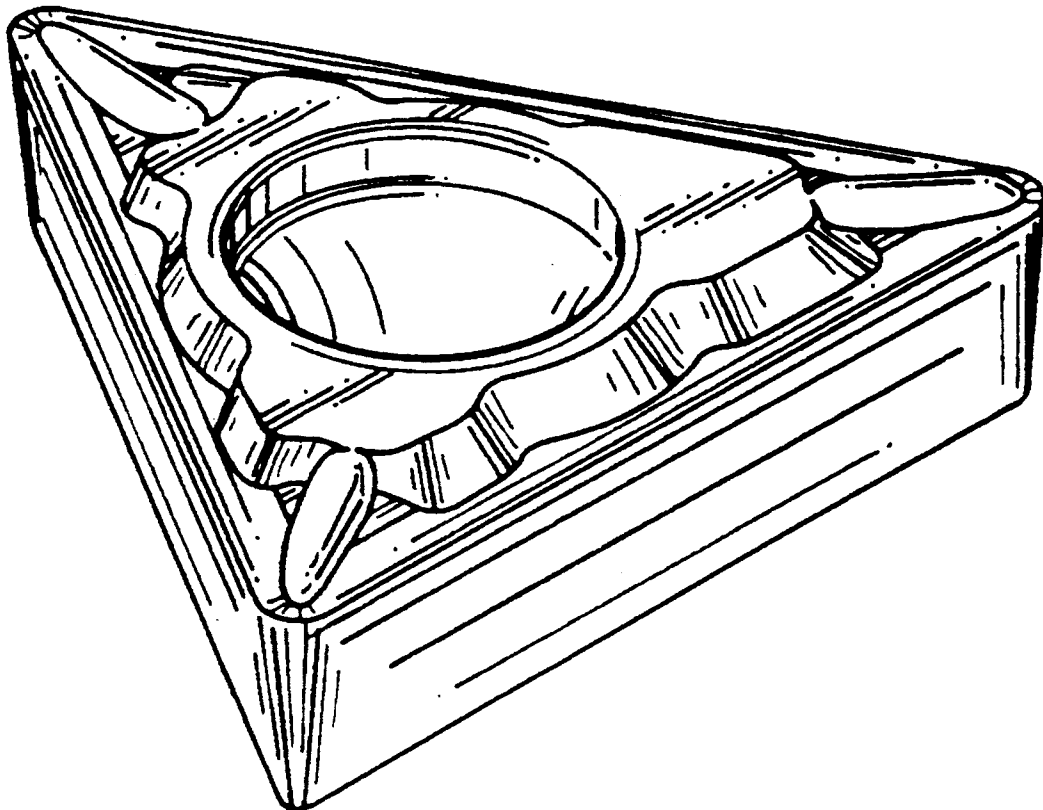

FIG.1

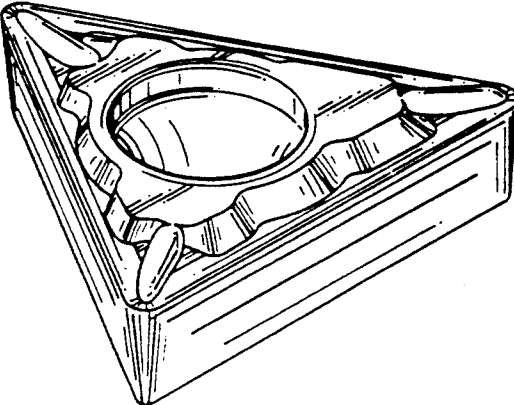

FIG.2

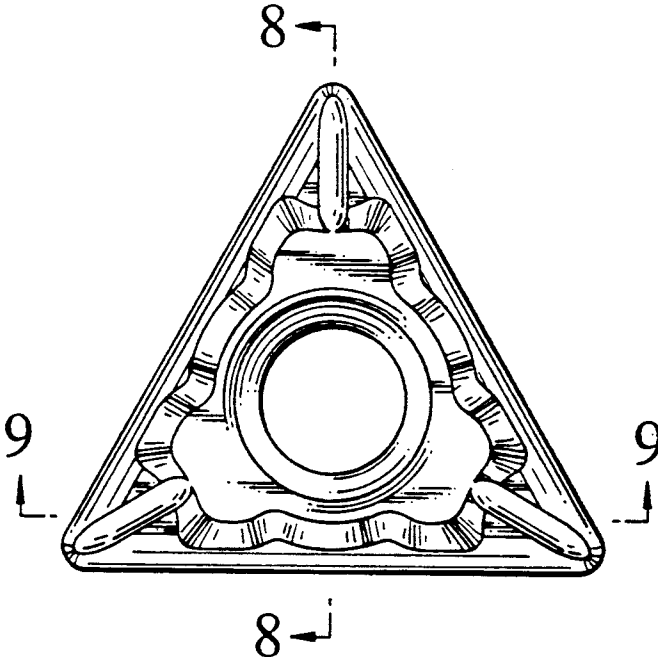

FIG.3

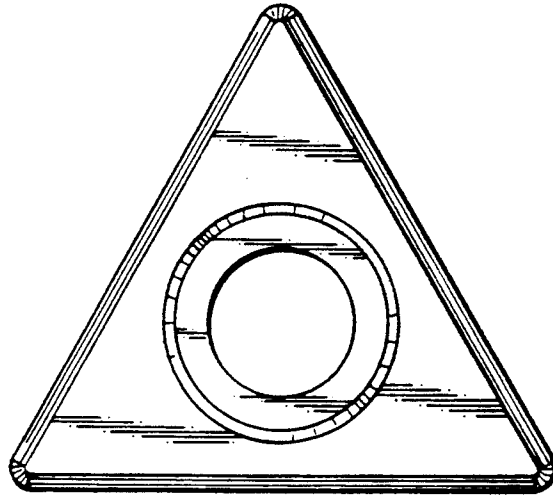

FIG.4

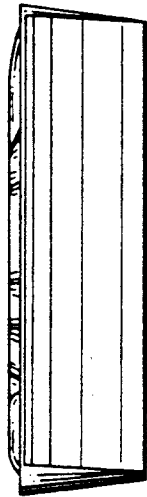

FIG.5



FIG.6

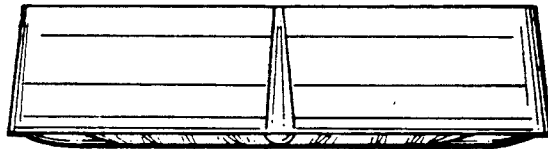

FIG.7

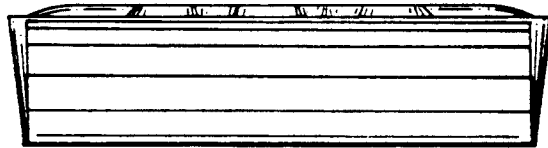

FIG.8

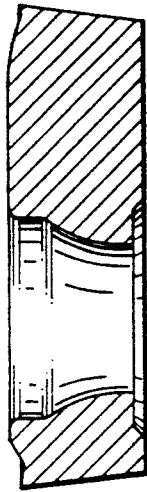

FIG.9

