

A. Q. ROSS,
Burglar Alarm.

No. 25,586.

Patented Sept. 27, 1859.

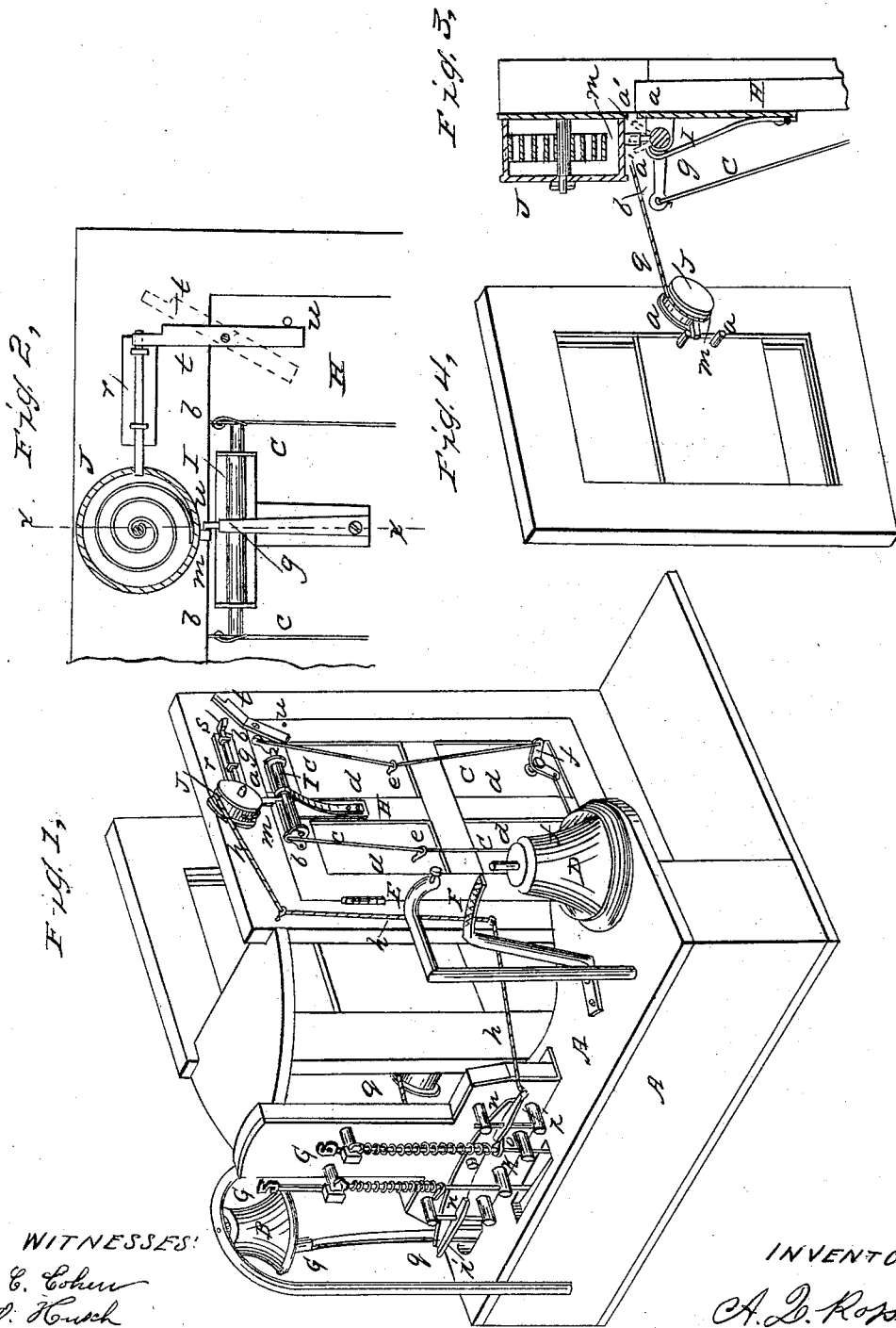

WITNESSES:
C. Cohen
D. Kusch

INVENTOR:
A. Q. Ross

UNITED STATES PATENT OFFICE.

ABBOTT Q. ROSS, OF CINCINNATI, OHIO.

BURGLAR-ALARM.

Specification of Letters Patent No. 25,586, dated September 27, 1859.

To all whom it may concern:

Be it known that I, ABBOTT Q. ROSS, of Cincinnati, in the county of Hamilton and State of Ohio, have invented certain new and useful Improvements in Burglar-Alarms; and I do hereby declare the following to be a full, clear, and exact description of the construction and operation of the same, reference being had to the accompanying drawings, making a part of this specification, in which—

Figure 1 represents in perspective so much of the apparatus, as will illustrate how the same may be arranged throughout an entire building. Fig. 2 represents some of the details of the mechanism, on an enlarged scale. Fig. 3 represents a section through the red line *x, x*, of Fig. 2. Fig. 4 represents the plan of connecting the apparatus, with a window.

Similar letters of reference where they occur in the several figures, denote like parts of the apparatus in all of them.

Burglar alarms as at present arranged are ineffectual, inasmuch as the burglar has only to cut the wires by which they are operated, to render them entirely inoperative; or, instead of forcing a door or window to gain access, they have only to cut out a panel from either, and such removal would not let off the alarm.

The object of my invention is to cause an alarm or signal to be given, whether the doors or windows be forced, or whether a panel from either be cut or removed, or whether the wires be cut or uncut, so that any attempt on the part of a burglar to enter a building in any of their ingenious ways, shall give an alarm or signal or both.

Another difficulty, with the system of burglar alarms, as now applied, consists, in requiring the alarm to be set by a person on the inside of the building, while it is often desirable that the house may be unoccupied for a greater or less period of time, and that the front or exit door, should, when drawn to from the outside of the house, be connected to or with the alarm apparatus. Such a connection I have contrived, and this is another feature in my invention.

The nature of my invention consists in connecting the doors or windows of a building with an alarm or signal apparatus, by means of cords or wires that are under tension, so that the forcing of the door or window, or the cutting of the wire, either, shall

let off the alarm or signal apparatus. And secondly my invention consists in connecting the panels of a door or window with an alarm or signal apparatus, by means of cords or wires under tension, so that the forcing of the door or window, or the cutting out, or disturbing a panel in either, or cutting any one of the wires, shall let off said alarm or signal apparatus or both of them. And thirdly my invention consists in so arranging the alarm or signal apparatus with one or more of the doors of the building as that by drawing to, said door, from the outside it shall be connected with said alarm or signal apparatus, and so connected that any attempt to force it, cut out and remove its panels, or to cut its wires shall let off the alarm or signal mechanism or both.

To enable others skilled in the art to make and use my invention, I will proceed to describe the same with reference to the drawings.

I am perfectly aware that, bells have been rung, lamps lighted, and the particular room or part of the house assailed, indicated, by mechanism let off by attempting to force the doors or windows of a house. I am also aware that, alarms have been given, by the burning off, of a cord or cords, in case of fire, and the location of the fire indicated. And I am also aware that, an electromagnetic alarm apparatus has been used, which by breaking or closing the circuit, causes signals to be given, and indicates the place where an attack is made. But I claim none of these things independent of the use of my strained wires or cords, and of my mechanism for effecting the objects herein stated, as will be now explained.

A represents a box for containing any ordinary clockwork mechanism that, can be let off by an escapement, and made to ring a bell, light a lamp and indicate the locality of the place from where it was let off. Such mechanism being common and well known need not be specifically described.

B represents the bell, *c* its hammer or capper; D, a lamp, E a swinging arm to carry a match which is drawn across the rough or sanded surface F, to ignite it, and then to the lamp wick.

G, G, are the annunciators which indicate the particular door, window, room, or place where any burglarious attempt to enter is made. This box with its clockwork, escapement, bell, lamp, and annunciator, may be

placed in any suitable or convenient part of the house or building; and the wires or cords that are attached to the various doors or windows of the house are connected there-
5 with as will be described

H, may represent one of the doors of a house (say for instance the front door) to which is connected a shaft I, in bearings in which it can turn, said shaft having a stud *a*
10 upon it near its center, and its ends or journals furnished with bell crank levers *b, b*, to which the wires *c, c* are connected, these wires being also connected together, and to each panel *d* of the door, either by dead-
15 eyes *e, e*, or bell cranks *f, f*, as may be preferred.

g, is a spring which bears against the stud *a*, and the wires *c, c*, are so strained up as to expand said spring, which in turn keeps the
20 wires thus under strain or tension. Over the door there is a drum J, that has a coiled spring within it, and to this drum is connected one end of a wire *h*, the other end thereof being taken by proper means through the
25 building to the alarm box, and there secured to a spring trigger or escapement *i*, which holds down its particular annunciator rod *k*—which in this case is furnished with a
30 figure 6, that figure representing the front door of the house. The drum J, has upon it a stud *m*, which when its spring is wound up, and its wire *h*, consequently strained up, rests against the stud *a* of the roller I, and the straining up of the wire *h*, draws the
35 trigger *i*, against the action of a spring *n*, until the end of the trigger *i*, catches over a stud or projection *o*, on the annunciator rod *k*, and thus holds down said rod upon a lever in the box A. The annunciator rod *k*
40 when held down as above mentioned, is so held, against the action of a spring *p*, and the moment the cord or wire *h*, is slacked or loosened from its strained position, the spring *n*, throws around the trigger *i*, and
45 releases the indicator rod *k*, which flies up, and thus lets off the clockwork which in turn sounds the alarm, or lights a lamp or both, and the figure (in this case 6) indicates that the door H, has been in some way disturbed.
50 This shows the action and operation of one alarm contrivance; every door and window in the house may be similarly united to the alarm apparatus though generally speaking, those of the lower story of the house, and
55 most exposed to burglars may only be so arranged.

The letting off of the alarm, by any disturbance of the front door, or door H, whether by forcing the door, cutting out a
60 panel, or cutting the wires connected therewith is as follows: The wire *h* is under tension through the spring in the drum J; and the wires *c*, are also under strain or tension through the action of the spring *g*, and they
65 are so held by the two studs *a, m*, bearing

against each other neither allowing the other to pass. Now it is obvious that if the stud *a*, by any means, is put in the position shown by red lines in Fig. 3, that the drum
70 J, will turn on its axis, and slacken the wire *h*, allowing it to unwind from the drum, and this slack trips the indicator rod *k*, and lets off the alarm apparatus. Should, for instance, the door H, be forced open, the stud
75 *a* would slip off from the stud *m*, in the direction of *a'*; or, if one of its panels *d* be cut out or removed, or any one of the wires *c* be cut, then the spring *g* would force away the stud *a* in the direction of *a'*, and either
80 would let the drum J, turn, and slacken its wire *h*, which as above described lets off the alarm mechanism, and this same system may be carried out throughout the house, the object being to connect the doors or windows
85 of a house with an alarm mechanism, by means of strained wires the slackening of any one of which will let off the alarm mechanism, and this straining may be done by springs or weights as are found most convenient.
90

In Fig. 4, I have shown how the mechanism may be applied to a window, so that raising or lowering the window, or disturbing it, may by slacking the wire *g*, effect the same object as that described in connection
95 with the door, the window being designated by the annunciator marked 5, the rod of which will also in flying up, let off the clockwork in the box A, and through it the alarm and signal apparatus.
100

During the day, the doors used for entrance and exit, must be disconnected from the alarm apparatus, or the alarm apparatus held from being let off, by opening said
105 doors. I effect this by a bolt *r* that shoots into a recess in the drum J, and thus prevents it from turning, though the springs may not during the daytime be strained up at all, in which event no alarm would be given by opening the door. But as this
110 straining up and setting of the alarm is easily done by a person on the inside of the house, it is not so easy for him to leave the premises, pull to the door out of which he passed, and leave that door connected in-
115 side to the alarm apparatus, so that if it is forced or assailed it will give an alarm. To effect this desirable object, is the main feature of the bolt *r*. When the alarm mechanism is all set, the bolt *r*, is shot into its recess, and then the door H, may be swung at
120 pleasure without affecting said mechanism. Now suppose the last occupant of the house to leave through the door H, which is not connected with the alarm, he has only to
125 swing a bent lever *t*, until its lower end comes against a pin *u* set in the door, which brings said lever into a perpendicular position as shown in black lines in Fig 2, and by pulling to the door from the outside of the
130

house, the top of the lever *t*, strikes against a cam or inclined plane *s*, on the end of the bolt *r*, and thus draws it out of its recess.

When this is done the stud *a*, is in the position to catch and hold against the stud *m* of the drum J, and prevents said drum from turning, so that the door is shut to from the outside but in doing so is put in connection with the alarm mechanism on the inside.

10 When the lever is in the position shown in Fig. 1, and by red lines in Fig 2, it will not disturb or touch the bolt *r*.

Having thus fully described the nature and object of my invention, what I claim therein as new and desire to secure by Letters Patent is—

1. Connecting the doors or windows of house to an alarm mechanism through a system of strained wires, so that the forcing of a door, or, the cutting of any wire, shall let

off the alarm mechanism substantially in the manner described.

2. I also claim so connecting the panels of a door with the strained wires that unite the door with the alarm mechanism, as that the cutting out of a panel or the cutting of one of their wires, shall let off the alarm mechanism, substantially as herein described.

3. I also claim the combination of the swinging lever *t*, on the door, with the bolt *r*, and its inclined plane *s* that locks the spring drum J, for the purpose of putting said door in connection with the alarm mechanism when said door is drawn to and shut from the outside, substantially as herein described and represented.

A. Q. ROSS.

Witnesses:

E. COHEN,
T. HIRSCH.