

Sept. 13, 1949.

F. F. ZEIER  
LOOP-SPREADER MECHANISM FOR CHAIN-STITCH  
SEWING MACHINES

2,482,079

Filed March 4, 1947

4 Sheets-Sheet 1

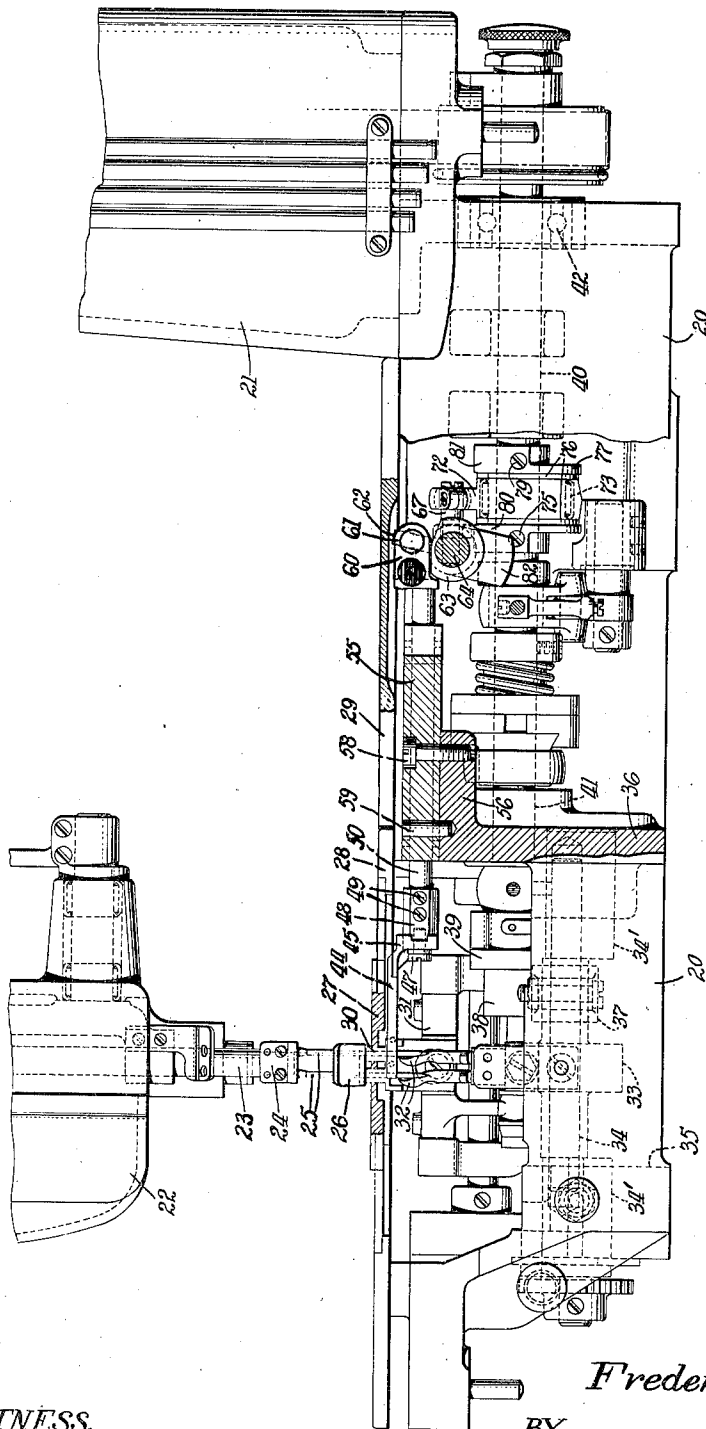

*Fig. 1.*

INVENTOR:

*Frederick F. Zeier*

BY:

*William P. Stewart*

ATTORNEY.

WITNESS.

*N. Leszczak*



Sept. 13, 1949.

F. F. ZEIER  
LOOP-SPREADER MECHANISM FOR CHAIN-STITCH  
SEWING MACHINES

2,482,079

Filed March 4, 1947

4 Sheets-Sheet 3

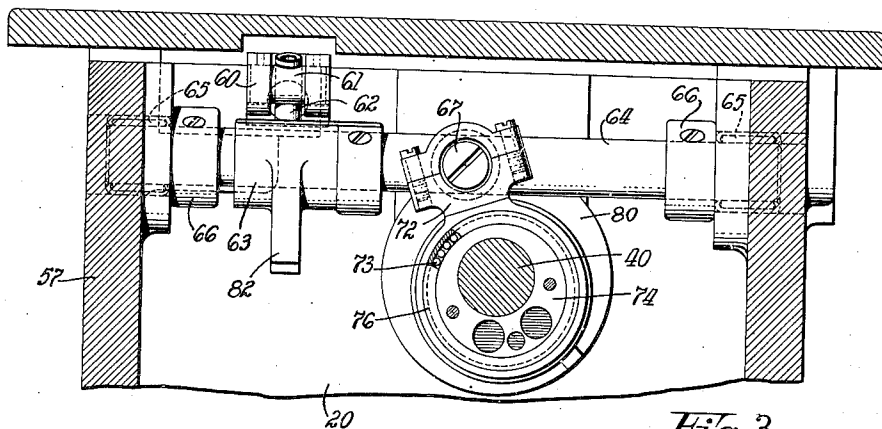

Fig. 3.

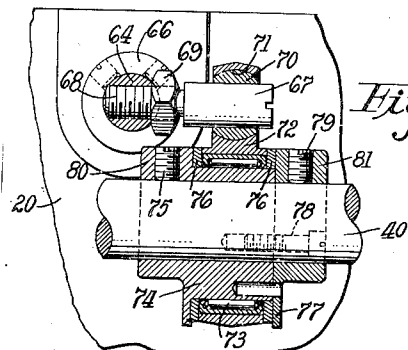

Fig. 4.

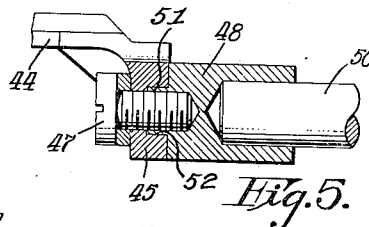

Fig. 5.

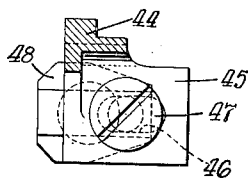

Fig. 6.

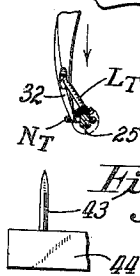

Fig. 7.

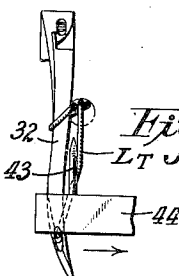

Fig. 9.

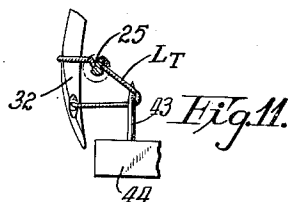

Fig. 11.

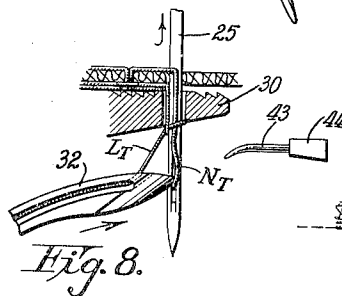

Fig. 8.

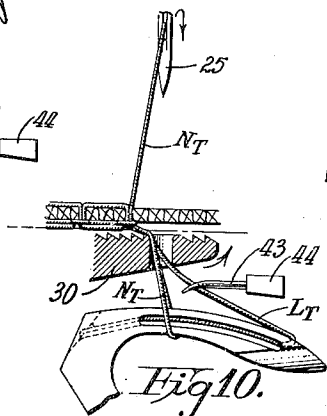

Fig. 10.

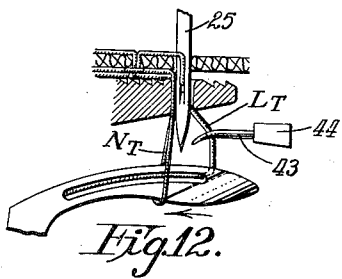

Fig. 12.

WITNESS.

N. Leszczak

INVENTOR.  
Frederick F. Zeier

BY.  
William P. Stewart  
ATTORNEY

Sept. 13, 1949.

F. F. ZEIER  
LOOP-SPREADER MECHANISM FOR CHAIN-STITCH  
SEWING MACHINES

2,482,079

Filed March 4, 1947

4 Sheets-Sheet 4

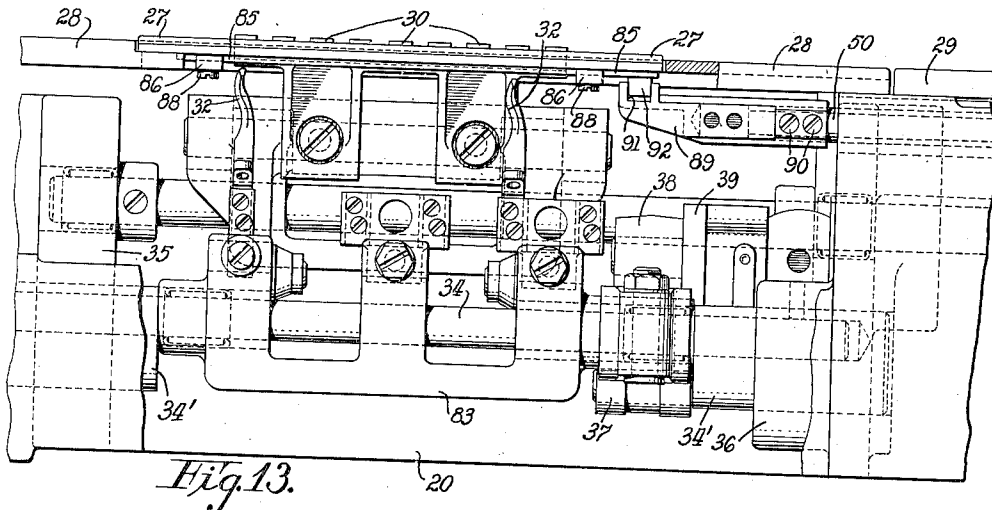

Fig. 13.

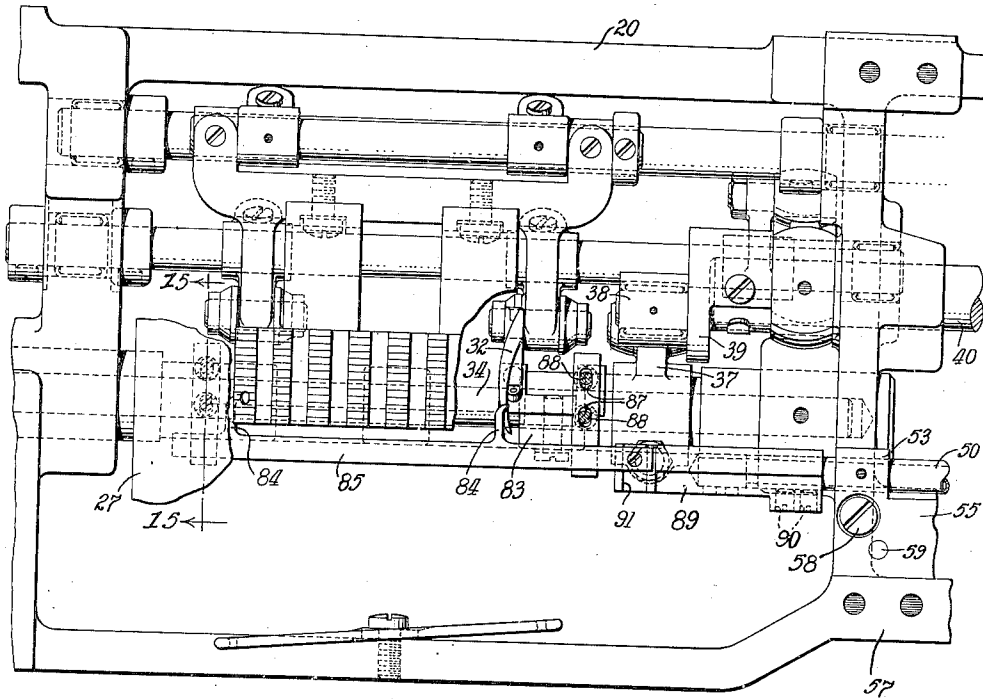

Fig. 14.

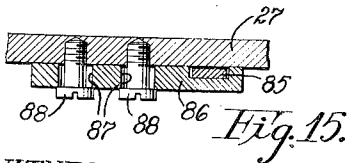

Fig. 15.

WITNESS.

N. Leszczak

INVENTOR.

Frederick F. Zeier

BY.

William P. Stewart

ATTORNEY.

# UNITED STATES PATENT OFFICE

2,482,079

## LOOP-SPREADER MECHANISM FOR CHAIN-STITCH SEWING MACHINES

Frederick F. Zeier, Stratfield, Conn., assignor to  
The Singer Manufacturing Company, Elizabeth, N. J., a corporation of New Jersey

Application March 4, 1947, Serial No. 732,184

6 Claims. (Cl. 112—199)

1

This invention relates to sewing machines and more particularly to those of the two-thread chain-stitch type employing a thread-carrying looper, and the invention has for an object to provide an improved loop-spreading mechanism for engaging and spreading one limb of the looper-thread-loop to form with the needle-thread-loop which is about the looper the usual thread-triangle for entrance by the descending needle in forming the succeeding stitch.

Another object of the present invention is to provide a loop-spreader actuating mechanism having the component parts thereof so arranged that a minimum of effort is required to operate the mechanism, the parts can be readily assembled, manufacturing tolerances can be reasonably large, and necessary repair including the replacement of parts can be accomplished without excessive disassembly.

A further object of the present invention is to provide a loop-spreading mechanism in which the thread-engaging element may be universally adjusted in order to effect a very satisfactory timing of the thread-engaging element with the other stitch-forming devices.

With the above and other objects in view, as will hereinafter appear, the invention comprises the devices, combinations and arrangements of parts hereinafter set forth and illustrated in the accompanying drawings of a preferred embodiment of the invention and the advantages attained thereby will be readily understood by those skilled in the art.

In the drawings,

Fig. 1 is a front side elevational view, with a portion of the bed and cloth-plate in section, of a sewing machine embodying the present invention.

Fig. 2 is an enlarged top plan view of a portion of the machine-bed; the cloth-plate and the throat-plate having been removed to show more clearly the mechanisms within the bed.

Fig. 3 is a transverse vertical sectional view taken substantially along the line 3—3, Fig. 2, showing the eccentric drive for the spreader mechanism and the anti-friction bearing interposed between the periphery of the actuating eccentric and the pitman strap embracing said eccentric.

Fig. 4 represents a longitudinal vertical sectional view taken substantially along the line 4—4, Fig. 2.

Fig. 5 represents a longitudinal vertical sec-

2

tional view taken substantially along the line 5—5, Fig. 2.

Fig. 6 represents a transverse vertical sectional view taken substantially along the line 6—6, Fig. 2.

Fig. 7 is a fragmentary top plan view of the looper and spreader, illustrating the looper just entering the needle-thread-loop during the loop-seizing stroke of the looper.

Fig. 8 is a right side elevational view, partly in section, of the elements shown in Fig. 7.

Fig. 9 is a view similar to Fig. 7, but showing the looper at the end of its loop-seizing stroke and the spreader engaging one limb of the looper-thread-loop preparatory to distending the same for entrance by the needle on its next work-penetrating stroke.

Fig. 10 is a right side elevational view, partly in section, of the elements shown in Fig. 9.

Fig. 11 is a view similar to Fig. 9, but showing the looper retracting to shed the needle-thread-loop and the looper-thread-loop fully distended by the spreader.

Fig. 12 is a right side elevational view, partly in section, of the elements shown in Fig. 11.

Fig. 13 is a fragmentary front side elevational view of the sewing machine bed, showing a modification of the spreader-carrying arm adapted for use on a wide gauge machine.

Fig. 14 is a top plan view, with the cloth-plate and throat-plate removed, of that portion of the sewing machine bed shown in Fig. 13.

Fig. 15 represents an enlarged vertical sectional view taken substantially along the line 15—15, Fig. 14.

Referring more in detail to the drawings, the invention is shown as embodied in a sewing machine comprising a frame including a bed 20 from one end of which rises a standard 21 of an overhanging bracket-arm terminating in a head 22. Journalled in the head 22 for endwise reciprocatory and laterally vibratory movements is a needle-bar 23 carrying at its lower end a needle-clamp 24 in which is fastened a pair of eye-pointed thread-carrying needles 25. The needles 25 are adapted to penetrate work sustained on the work-support by a common form of presser-foot 26, which work-support includes a throat-plate 27 and cloth-plates 28 and 29. The work is fed through the machine by means of the vibratory needles 25 and the cooperating feed-dog 30 supported on a feed-bar 31 which derives its usual feeding motions from mechanism substantially similar to that forming the subject of

my prior Patent No. 2,292,258, issued August 4, 1942.

Cooperating with the threaded needles 25 in forming two-thread chain-stitches are the thread-carrying loopers 32 supported for oscillation in a vertical plane parallel to the line of feed in a looper-carrier 33 mounted on a fixed fulcrum-shaft 34 supported at opposite ends in bushings 34' located in the transverse partitions 35 and 36 of the bed 20. The looper-carrier 33 is actuated through a rock-lever 37 and link 38 from a crank 39 mounted on the end of a rotary main or bed-shaft 40 journaled in suitable bearings 41 and 42 (Fig. 1) provided in the bed 20. It will be understood that the loopers 32 have only loop-seizing and loop-shedding strokes and that these two motions are coordinated with the reciprocatory and vibratory feeding movements of the needles 25 to effect stitch-formation.

To assist in proper stitch-formation, each of the two-motion loopers 32 has cooperating therewith a spreader-finger 43 (Fig. 2) which is adapted to engage and distend one limb of the looper-thread-loop to form the usual thread-triangle with the previous needle-thread-loop for entrance by the descending needle. In one embodiment of the invention as applied to a narrow gauge machine (needles set relatively close to each other), the spreaders 43 are preferably rigidly fastened to a flat carrier or arm 44 formed with a shank 45. The shank 45 is slotted, as at 46, through which extends a clamp-screw 47 threaded into a carrier-arm holder or block 48 secured by set-screws 49 on the forward end of an endwise reciprocatory actuating or spreader-supporting bar 50. Adjustment of the spreader-fingers 43 vertically and horizontally in a direction toward or away from the loopers 32 is accomplished by loosening the set-screws 49 and turning or shifting the block 48 on the spreader-supporting bar 50, while adjustment of the spreader-fingers in a substantially horizontal direction parallel with the line of feed is accomplished by backing off the clamp-screw 47 and shifting the carrier 44 relative to the block 48. The block 48 is formed with a tongue 51 adapted to project into a groove 52 provided in the shank 45 of the carrier 44, limiting shifting of the carrier 44 relative to the block 48 in a right line.

The spreader-supporting bar 50 is journaled for endwise movement in the spaced bearings 53 and 54 (Fig. 2) of a bearing-bracket 55 detachably secured on a supporting lug 56 cast integral with the front wall 57 and transverse partition 36 of the bed 20, the screws 58 and locating pins 59 serving to fasten the bracket 55 in its aligned position. The rearward end of the spreader-supporting bar 50 is preferably formed as a yoke 60 in the limbs of which is freely journaled a horizontally disposed connector-pin 61 apertured, normal to its longitudinal axis, to slidably receive the upwardly extending cylindrical lever-pin 62 of a driving rock-arm 63. The rock-arm 63 is fastened on a transverse spreader-driving rock-shaft 64 journaled at its opposite ends preferably in needle-bearings 65 pressed into the side-walls of the bed 20, as clearly shown in Fig. 2. The spreader-driving shaft 64 is restrained against endwise shifting in its bearings 65 by two collars 66 clamped on the shaft 64. The means for rocking the spreader-driving shaft 64 comprises a horizontal rock-arm (Fig. 4) having a cylindrical body 67 provided with a shank 68 threaded into the spreader-driving shaft 64, a lock-nut 69 serving to prevent

accidental unthreading of said rock-arm. Slidably embracing the cylindrical body 67 of the rock-arm is a sleeve-ball 70 seated in a socket 71 formed in the split upper end of an actuating pitman 72. The lower end of the pitman 72 embraces a needle-bearing 73 fitted on an actuating eccentric 74 secured by set-screws 75 on the rotary bed-shaft 40. Disposed on opposite sides of the pitman 72 are two thrust-washers 76; the pitman 72, needle-bearing 73 and thrust-washers 76 being retained on the actuating eccentric 74 by a flange 77 secured against the face of the eccentric 74 by screws 78 and locked on the rotary bed-shaft 40 by the set-screws 79. To minimize vibration during high speed operation of the mechanism, the eccentric 74 is formed with a weighted section 80 and the flange 77 is formed with a similar weighted section 81, the two sections 80 and 81 being disposed diametrically opposite the point of maximum eccentricity of the eccentric 74. To further assist in balancing the spreader mechanism, the driving rock-arm 63 is formed with a depending counterbalance 82 (Figs. 1 and 3).

The actuating eccentric 74 is timed so that the spreader-finger 43 is reciprocated crosswise of the line of seam formation at the proper time to spread the thread leading from the looper-eye to form the usual thread triangle with the previous needle-loop which is about the blade of the looper for proper entrance by the descending needle. The functioning of the spreader is illustrated in Figs. 7 to 12, inclusive. In Figs. 7 and 8, the needle 25, after reaching the lowermost point of its stroke, has begun its ascending stroke and has cast out a thread-loop  $N_T$  which is just being entered by the beak of the looper 32. During this part of the stitch-forming cycle, the spreader 43 does not perform any useful function. Figs. 9 and 10 disclose the looper at the end of its loop-seizing stroke and the needle 25 at the highest point of its stroke. It will be seen that the spreader 43 has engaged a limb of the looper-thread  $L_T$  and is preparing to carry said limb to a position further to the right. Figs. 11 and 12 disclose the looper 32 retracting to shed the needle-thread-loop  $N_T$ , the needle 25 descending to enter the thread triangle and the spreader 43 at the end of its loop-distending stroke. From the above, it will be understood that the spreader-finger 43 engages and spreads one limb of the looper thread so that the needle 25 on its descending stroke will unerringly enter the spread thread-triangle, regardless of the fact that the needle-aperture is not stationary but is formed in the feed-dog 30 and shifts back and forth in the line of feed.

Figs. 1, 2, 5 and 6 are illustrative of a spreader mechanism as applied to a narrow gauge sewing machine, i. e. one in which the needles and loopers are relatively closely spaced. Figs. 13 and 14 disclose a modification of the spreader mechanism which is adapted for wide gauge sewing machines. Referring to these two figures it will be observed that the loopers 32 are widely spaced and are supported by a looper-carrier 83 journaled for oscillation on a fixed fulcrum-shaft 34 supported at opposite ends in the bushings 34' located in the transverse partitions 35 and 36 of the bed 20. The looper-carrier 83 is oscillated on the fulcrum-shaft 34 by the same means hereinbefore described in connection with the looper-carrier 33. Cooperating with the widely spaced

5

loopers 32 are the spreader-fingers 84 (Fig. 14) preferably integral with a carrying-bar 85. The carrying-bar 85 preferably has a rectangular cross-section and is supported adjacent its opposite ends for endwise reciprocation against the under side of the throat-plate 27 by two slotted bearing-blocks or guides 86, each of the bearing-blocks being provided with elongated holes 87 through which extend screws 88 threaded into the throat-plate 27. The elongated holes 87 provide for limited adjustment of the spreader-fingers 84 in a plane parallel to the under surface of the throat-plate 27. The spreader carrying-bar 85 is reciprocated endwise by the actuating bar 50 and the means employed for connecting said carrying-bar 85 to said actuating bar 50 preferably comprises a connector-head 89 secured on the outer end of the actuating bar 50 by the set-screws 90 affording limited adjustment of said head lengthwise of said actuating bar 50. The other end of the connector-head 89 is formed with a channel 91 opening into the upper face of the connector-head, into which open topped channel projects a block 92 depending from the right hand end portion of the carrying-bar 85. The block-and-channel connection with the actuating bar 50 facilitates removal of the throat-plate 27 and spreader-fingers 84 as a unit from the machine cloth-plate 28. The block-and-channel connection also accommodates whatever misalignment which may exist between the carrying-bar 85 and the actuating-bar 50.

From the foregoing, it will be understood that I have devised a spreader operating mechanism having the component parts thereof interconnected in a manner to eliminate binding in the event the parts are slightly misaligned. In fact, by virtue of the universal connections between the various elements of the operating mechanism, manufacturing tolerances as far as alinement is concerned may be large and therefore easily obtainable. The presence of the detachable bearing-bracket 55 is advantageous owing to the fact that machining of the bed 20 is simplified and the final assembly of the spreader operating mechanism is facilitated. The universal adjustment of the spreader-fingers relative to the loopers permits the accurate timing of the spreader-fingers with respect to the movements of the loopers, resulting in a perfect cooperation between said spreader-fingers and loopers.

Having thus set forth the nature of the invention, what I claim herein is:

1. In a sewing machine having a frame including a bed, the combination with a thread-carrying reciprocatory needle, of complemental stitch-forming mechanism including a thread-carrying looper, means for imparting loop-seizing and loop-shedding movements to said looper, a loop-spreader, means for operating said loop-spreader including an actuating bar provided with a connector-pin, a bracket detachably secured to said bed and providing a bearing for said actuating bar, a rock-shaft, means for operating said rock-shaft, and means connecting said rock-shaft to said actuating bar including a rock-arm fast on said rock-shaft and having a lever-portion thereof slidably disposed in said connector-pin.

2. In a sewing machine having a frame including a bed, the combination with a thread-carrying reciprocatory needle, of complemental stitch-forming mechanism including a thread-carrying looper, means for imparting loop-seizing and loop-shedding movements to said looper, a loop-spreader movable transversely of the movements

6

of said looper, an endwise movable loop-spreader actuating bar provided with a connector-pin, a carrier for said loop-spreader adjustably secured on said actuating bar, a bracket providing a bearing for said actuating bar detachably secured to said bed, a rock-shaft, means for operating said rock-shaft, and means connecting said rock-shaft to said actuating bar including a rock-arm secured on said rock-shaft and having a lever-portion thereof slidably disposed in said connector-pin.

3. In a sewing machine having a frame including a bed, the combination with a thread-carrying reciprocatory needle, of complemental stitch-forming mechanism including a thread-carrying looper, means for imparting loop-seizing and loop-shedding movements to said looper, a loop-spreader, an actuating bar supporting said loop-spreader and endwise movable in a direction substantially normal to the loop-seizing and loop-shedding movements of said looper, a rock-shaft journaled in said bed transversely of said actuating bar, a rotary shaft journaled in said bed, means including a universal connection for operatively connecting said rock-shaft to said rotary shaft, and means including a second universal connection for connecting said actuating bar to said rock-shaft.

4. In a sewing machine having a frame including a bed, the combination with a thread-carrying endwise movable needle, of complemental stitch-forming mechanism including a thread-carrying looper, means for imparting loop-seizing and loop-shedding movements to said looper, a loop-spreader, an actuating bar endwise movable in a direction substantially normal to the loop-seizing and loop-shedding movements of said looper, a holder mounted on said actuating bar, a carrier for said loop-spreader adjustably secured to said holder, a rock-shaft journaled in said bed and disposed transversely of said actuating bar, means for operating said rock-shaft, and means operatively connecting said actuating bar to said rock-shaft, said means having capacity to accommodate slight misalignment between said actuating bar and said rock-shaft.

5. In a sewing machine having a frame including a bed, the combination with a thread-carrying endwise movable needle, of complemental stitch-forming mechanism including a thread-carrying looper, means for moving said looper so that the beak thereof travels in a vertical plane, a loop-spreader, a bracket detachably secured to said bed, an actuating bar journaled in said bracket for reciprocation in a direction substantially normal to the plane of movement of said looper-beak, means adjustably securing said spreader to one end of said actuating bar, a rock-shaft journaled in said bed and disposed substantially parallel with the plane of movement of said looper-beak, means including a universal connection operatively connecting said rock-shaft with said actuating bar, a rotary main-shaft journaled in said bed and disposed substantially parallel to said actuating bar, and means connecting said rock-shaft to said rotary main-shaft.

6. In a sewing machine having a frame including a bed and a removable throat-plate, the combination with an endwise reciprocatory thread-carrying needle, of complementary stitch-forming mechanism including a thread-carrying looper, means for imparting loop-seizing and loop-shedding movements to said looper, a loop-spreader, a carrying-bar supported for endwise sliding movement on the under side of said

7

throat-plate, a block depending from said carrying-bar, an actuating bar journaled for endwise reciprocation in said bed, means for reciprocating said actuating bar, and a connector-head fixed on said actuating bar having an open topped channel into which projects the block depending from said carrying-bar.

FREDERICK F. ZEIER.

8

REFERENCES CITED

The following references are of record in the file of this patent:

UNITED STATES PATENTS

Number	Name	Date
1,443,084	Moffatt et al. _____	Jan. 23, 1923
1,995,078	Rubel _____	Mar. 19, 1935
2,312,858	Zeier _____	Mar. 2, 1943