



(11) **EP 3 246 477 B1**

(12) **EUROPEAN PATENT SPECIFICATION**

(45) Date of publication and mention of the grant of the patent:
29.11.2023 Bulletin 2023/48

(51) International Patent Classification (IPC):
E03D 9/00 (2006.01) E03D 9/02 (2006.01)
E03D 9/03 (2006.01)

(21) Application number: **17171086.6**

(52) Cooperative Patent Classification (CPC):
E03D 9/032; E03D 9/02; E03D 2009/026

(22) Date of filing: **15.05.2017**

(54) **SANITIZING DEVICE, PARTICULARLY FOR SANITARY FIXTURES AND THE LIKE AND CORRESPONDING METHOD OF FILLING**

DESINFEKTIONSVORRICHTUNG, INSBESONDERE FÜR SANITÄRARMATUREN UND DERGLEICHEN SOWIE ENTSPRECHENDE VERFAHREN ZUM FÜLLEN

DISPOSITIF DE DÉINFECTION, EN PARTICULIER POUR APPAREILS SANITAIRES ET ANALOGUES ET PROCÉDÉ DE REMPLISSAGE CORRESPONDANT

(84) Designated Contracting States:
AL AT BE BG CH CY CZ DE DK EE ES FI FR GB GR HR HU IE IS IT LI LT LU LV MC MK MT NL NO PL PT RO RS SE SI SK SM TR

(30) Priority: **16.05.2016 IT UA20163446**

(43) Date of publication of application:
22.11.2017 Bulletin 2017/47

(73) Proprietor: **Bolton Manitoba S.p.A.**
20124 Milano (IT)

(72) Inventors:
• **ALDERUCCIO, Gianni**
20832 Desio MB (IT)
• **BAIGUERRA, Gianpaolo**
20020 Arese MI (IT)
• **BRIGNOLI, Cinzia**
20135 Milano (IT)

• **BIANCHI, Raoul**
20811 Cesano Maderno MB (IT)
• **NOVITA', Luciano Mario**
20090 Segrate MI (IT)
• **PIMAZZONI, Massimiliano**
21042 Caronno Pertusella VA (IT)

(74) Representative: **Meroni, Francesca**
Jacobacci & Partners S.p.A.
Via Senato, 8
20121 Milano (IT)

(56) References cited:
EP-A1- 1 978 080 EP-A1- 2 620 489
EP-A2- 0 940 509 EP-A2- 2 407 601
WO-A1-2014/031159 DE-A1- 10 020 090
FR-A1- 2 258 320 GB-A- 2 401 791
GB-A- 2 416 785 GB-A- 191 311 185
US-A1- 2010 235 976 US-B1- 6 505 356

EP 3 246 477 B1

Note: Within nine months of the publication of the mention of the grant of the European patent in the European Patent Bulletin, any person may give notice to the European Patent Office of opposition to that patent, in accordance with the Implementing Regulations. Notice of opposition shall not be deemed to have been filed until the opposition fee has been paid. (Art. 99(1) European Patent Convention).

Description

[0001] The present invention relates to a method of filling a sanitizing device and to a sanitizing device, particularly for sanitary fixtures and the like. More specifically, the invention relates to a sanitizing device that is adapted to release a sanitizing product following the passage of water in contact with it or through it, and a method of filling the device itself.

[0002] As is known, for sanitizing sanitary fixtures devices are used that comprise a form of cage inside which a sanitizing product in tablet form is arranged.

[0003] The device is clipped to the sanitary fixture so as to remain in contact with the internal wall of the sanitary fixture, in particular in a position that corresponds to a point where water passes.

[0004] When the water is flushed, the water flows over or passes through the containment device of the tablet and the tablet releases sanitizing product in order to sanitize the sanitary fixture.

[0005] Currently, sanitization devices comprise containers of the cage type that are adapted to accommodate a product in tablet form which is constituted by a sanitizing product with gradual release. Such tablet is typically constituted by a solid material, accommodated in the cage, which dissolves upon the passage of water in contact with it.

[0006] Such tablets, however, have several problems.

[0007] Firstly the tablets have an unpleasant appearance, being opaque, and their outward appearance worsens as they are consumed.

[0008] Furthermore the tablets are made using inert substances such as sodium carbonate, sodium sulfate, sodium chloride, calcium carbonate etc, in order to confer a solid texture. The purpose of such inert substances are not linked to the performance of the product; they are only needed for the latter to have a solid texture. However, against this, some inert substances used tend to leak and therefore to leave undesired streaks on the inner surface of the sanitary fixture.

[0009] Furthermore, given the solid and rich nature of the inorganic substances in the tablet, the latter is very dense, with the drawback that in order to have a tablet of sufficient volume it is necessary to use a relatively high amount by weight of the product, with consequent high costs.

[0010] Even furthermore, the presence of inert substances and anionic surfactants is not a factor that favors the yield of the scent during use of the tablet, and the scent is one of the most important features in order to attract the consumer.

[0011] An alternative solution known in the background art for sanitizing sanitary fixtures relates to the use of gels, i.e. of adhesive substances in semisolid form, which are applied directly on the inner surface of the sanitary fixture. These solutions too, however, are not devoid of drawbacks. In particular, the application of gel directly on the wall of the sanitary fixture entails the need to come

into contact with that wall, a situation that is often unwanted for the user, irrespective of the conditions of cleanliness of the sanitary fixture. Furthermore, the application of a dose of gel on the wall is a much more complex operation than clipping to that sanitary fixture, since it entails exerting sufficient pressure, so as to make the dose of gel adhere to the wall, and a certain degree of dexterity in manipulating the device for applying the gel, whether it is in the form of a syringe (single dose or multidose) or in the form of a blister.

[0012] Finally, liquid tablets are known the content of which is therefore aqueous and free from inert substances. Such tablets contain liquids that are also viscous but, however, they exhibit the drawback of needing to be handled like a liquid and therefore the container that holds them must be perfectly closed, and in order to obtain the desired sanitizing effect it is necessary to provide complex and expensive mechanisms to allow the gradual release of the liquid in use.

[0013] Dispensing devices and/or products contained therein, are disclosed in FR 2 258 320 A1, EP 0 940 509 A2, GB 2 416 785 A, EP 2 620 489 A1, US 2010/235976 A1, EP 1 978 080 A1, GB 2 401 791 A, WO 2014/031159 A1, GB 11185 A, DE 100 20 090 A1, EP 2 407 601 A2, US 6 505 356 B1.

[0014] The product in gel form is very difficult to load into the container body, since, upon its insertion into the container body, which is conveniently provided with slits for the gradual release of the product, the gel tends immediately to leak out of the container body itself, thus making it substantially impossible to load the container body with the product in gel form.

[0015] FR 2 258 320 discloses a sanitizing device having a container body with slits and accommodating a water-soluble bag adapted to contain the sanitizing product.

[0016] EP 0940509 discloses a sanitizing device having a container body with slits adapted to contained a gel product that has to be cooled.

[0017] The aim of the present invention is to provide a sanitizing device and a method of filling a sanitizing device with a product in gel form, that overcomes the problems mentioned above with reference to the background art.

[0018] Within this aim, an object of the present invention is to provide a method of filling a sanitizing device for sanitary fixtures, in which the device has all the advantages of the gel but without requiring the user to come directly into contact with the internal wall of a sanitary fixture.

[0019] Another object of the present invention is to provide a method of filling a sanitizing device for sanitary fixtures that is highly reliable, easily and practically implemented and low cost.

[0020] This aim and these and other objects which will become better apparent hereinafter are achieved by the sanitizing device as described in claim 2 and by a method of filling a sanitizing device as defined in claim 1

[0021] Further characteristics and advantages of the

invention will become better apparent from the description of preferred, but not exclusive, embodiments of the sanitizing device according to the present invention, which are illustrate by way of non-limiting example in the accompanying drawings, wherein:

Fig.1 to 11 disclose embodiments of a dispensing device not falling within the scope of the claims.

Fig.12-14 disclose a dispensing device according to the invention.

[0022] With reference to the figures, the sanitizing device generally designated by the reference numeral 1, comprises a container body 2 that is adapted to define a form of cage for a sanitizing product, and a supporting stem 3, which is connected to the container body 2 and is adapted to be clipped to the edge of a sanitary fixture. The general term "sanitizing device" is used to indicate a sanitizing and/or scenting and/or cleaning device.

[0023] The supporting stem 3 can be provided at an angle with respect to the front surface of the container body 2, as shown in Figures 1-3, or it can be aligned with the front surface of the container body 2.

[0024] The container body 2 is adapted to contain a sanitizing product in gel form 4.

[0025] The container body 2 is provided with a plurality of slits 5 that are adapted to allow the release of the sanitizing product 4 in gel form, with the slits being advantageously arranged at the bottom surface of the container body 2, i.e. the surface that is adapted to be directed toward the wall of the sanitary fixture to which the sanitizing device is applied.

[0026] Advantageously, the slits are adapted to allow direct access to a stream of water in the toilet bowl.

[0027] Conveniently, the slits 5 are arranged so as to leave a central region 6 of the body of the container full, with the slits 5 extending laterally thereto.

[0028] This particular configuration of the slits 5 allows the container body 2 to be filled without the product in gel form 4 immediately leaking through the slits 5, as will be described in detail below.

[0029] Advantageously, it is possible to have, at the bottom surface of the container body 2, slits 5 that can also be continuous at the bottom of the container body 2, as long as they are provided in a certain dimension, as will be described in detail below.

[0030] An additional variation of the slits 5 provided at the bottom of the container body 2 entails that the slits widen as they extend upward with respect to the direction of pouring of the product in gel form, i.e. at the edge regions of the container body: in this case the slits widen in a region 7, arranged for example perpendicular to the extension of the slits.

[0031] The size of the slits is extremely important to ensure that upon pouring the product in gel form, which is to be loaded into the container body 2, the product does not exit from the slits proper.

[0032] In order to prevent such drawback, and there-

fore make it possible to provide a sanitizing device with a product in gel form loaded in it, the slits 5 can have various shapes and dimensions, with a size limit of 2 mm width.

5 **[0033]** Ultimately, the size limit indicated previously of 2 mm for the width of the slits 5 ensures that, upon pouring the product in gel form 4 into the body 2 of the container, the product does not exit from the slits proper.

10 **[0034]** To this end, the gel is conveniently heated and poured at a certain temperature so that it is at the same time pourable and as viscous as possible.

[0035] The heating temperature to which the gel is heated must be such that at the moment of pouring the gel has a minimum viscosity of 500 mPa*s.

15 **[0036]** In substance, what is required is to have a heating temperature of the gel such that the gel can have a viscosity that enables it to not leak through the slits 5 once it is loaded into the container body 2.

20 **[0037]** The actual filling temperature of the container body varies depending on the composition of the gel. For example aqueous gels containing ethoxylated alcohols can require, for pouring, temperatures comprised between 75° and 80°C; for other gels temperatures lower than 60°C can suffice. The important factor is that the gel is poured into the cage at a viscosity that is higher than 25 500 mPa*s or even more preferably even higher, between 800 and 1200 mPa*s.

30 **[0038]** The maximum width of 2 mm specified for the slits 5 makes it possible for the gel not to leak, as mentioned, upon the loading thereof into the container body 2, but at the same time it makes it possible to ensure the functionality, i.e. the passage of the water once the tablet in gel form is in use.

35 **[0039]** The method of pouring the gel into the container body 2 can also optionally entail, in addition to the heating of the gel indicated above, the contrivance of pouring the gel initially at a region where there are no slits or there are slits of very reduced thickness, so as to give time for the gel to constitute a certain mass such that it has greater 40 difficulty in exiting from the slits once the mass of gel reaches the region where the slits are arranged.

[0040] In the embodiment in which the slits 5 are interrupted at a region defined on the bottom surface of the container body 2, it is advisable to pour the gel exactly 45 in such region that is substantially free from slits 5, and therefore enable the mass of gel to then flow toward the region of the slits once the gel has created a mass that is such as to prevent the product in gel form from leaking through the slits 5 proper.

50 **[0041]** In the embodiment in which the slits 5 widen at a widened portion of slot 7, the portion 7 of slot will have a maximum size that can even exceed the 2 mm maximum indicated previously, as the portion 7 of slot is in a region of the container body 2 at its edges, a region that 55 is reached by the mass of gel loaded in the container body 2 when such mass is no longer capable of flowing through the slits, even if the slits 5 have a size greater than 2 mm.

[0042] The viscosity of the gel during the filling must preferably be approximately 800-1200 mPa*s measured with a Haake viscometer VT550 MV2 at 5s-1.

[0043] This value is a indicative, and non-limiting, of the preferred viscosity of the gel.

[0044] What is extremely important is that, during the step of pouring, the gel must initially encounter a surface that is locally closed or provided with slots of dimensions reduced sufficiently to prevent the exit of gel, in order to later progressively fill the containment device also at the slits 5.

[0045] In practice it has been found that the sanitizing device according to the present invention and the corresponding filling method achieve the intended aim and objects.

[0046] In fact, the device according to the invention makes it possible to be loaded with a tablet made with a product in gel form, with the product in gel form being loaded in the container body of the sanitizing device without the product in gel form exiting from the slits for releasing the product during loading.

[0047] This is due both to a particular choice of the maximum width dimension of the slits and to a particular choice of the method of loading the product in gel form, which entails that the loading occur initially on very thin slits or in a region substantially free from slits in order to then make the mass of gel flow to the other regions of the container (cage) when the accumulated mass is significant and no longer capable of leaking through the slits proper.

[0048] The use of gel inside a device of the type shown makes it possible to overcome the problems of the background art with regard to the use of solid sanitizing tablets, and the problems associated with the use of liquid tablets that require a completely closed container, and also the problems associated with the use of gel applied directly on a wall of the sanitary fixture.

[0049] In fact, the characteristics of the gel make it possible to provide containment devices that are open or partially open, for example with numerous openings in the upper and lower part of the cage (with respect to the flow of the water), and to take advantage of the rheological characteristics of the gel that enable its stable permanence inside a perforated container, even under the effect of streams of water. In the same way, the convenience remains unaltered of application to the sanitary fixture of a device of the cage type, which does not require particular dexterity or the need to come into contact with the internal wall of the sanitary fixture in order to directly apply a dose of gel.

[0050] The device and the method, thus conceived, are susceptible of numerous modifications and variations, all of which are within the scope of the appended claims.

[0051] Moreover, all the details may be substituted by other, technically equivalent elements.

[0052] In particular, the person skilled in the art will understand without effort that the shape of the container

body, as well as the dimensions and the shapes of the slits, can be many according to the method of filling adopted and depending on the composition of the gel. For example, it is possible to have a form of container body with inner walls that are arranged in a labyrinth-like fashion, such that the gel is poured at these walls and reaches a sufficiently solid state before arriving proximate to the slits that are necessary for the passage of water.

[0053] Figure 12 shows a device according to the invention in which the container body 2 is provided, at the upper surface thereof, which is adapted to be directed toward the opening of the sanitary fixture, with a plurality of walls 10 that are arranged in a labyrinth-like configuration and are mutually offset. In this case the container body has a boat-like shape and the walls 10 are vertical vanes.

[0054] Figure 13 shows a device according to the invention similar to the one of Figure 12, with the walls 10 provided with holes 11 or with slits 12.

[0055] Figure 14 shows a device according to the invention similar to the ones of Figures 12 and 13, in which the slits 5 defined on the container body 2 have a different orientation.

[0056] In practice the materials employed, and the contingent dimensions and shapes, may be any according to requirements and to the state of the art.

[0057] Where technical features mentioned in any claim are followed by reference signs, those reference signs have been included for the sole purpose of increasing the intelligibility of the claims and accordingly, such reference signs do not have any limiting effect on the interpretation of each element identified by way of example by such reference signs.

Claims

1. A method of filling a sanitizing device (1), comprising the steps of:
 - preparing a container body (2) for containing a sanitizing product in gel form (4), said container body (2) being provided with slits (5) that are adapted to allow a gradual release of said sanitizing product (4), said slits (5) having a maximum width of 2 mm that is such as to prevent the exit of the product in gel form (4) during the pouring of said product in gel form into said container body (2); said container body (2) is provided, at an upper surface thereof that is adapted to be directed, when installed, toward the opening of the sanitary fixture, with a plurality of walls (10) that are arranged mutually offset;
 - heating a product in gel form (4), the heating temperature to which the product in gel form is heated must be such that at the moment of pouring the gel product has a minimum viscosity of 500 mPa*s;

- pouring said product in gel form (4) into said container body (2), so that the product in gel form (4) initially comes into contact with a region of said container body (2) with no slits or with slits (5) having a maximum width that is such as to prevent the exit of the product in gel form (4) during the pouring of the product in gel form into the container body (2);
 - leaving the product in gel form (4) to expand inside said container body (2) and to reach a final viscosity with cooling of at least 50 Pa*s.
2. A sanitizing device (1) comprising a container body (2) containing a sanitizing product in gel form (4) having a viscosity of at least 50 Pa*s, said container body (2) being provided with slits (5) that are adapted to allow the gradual release of the sanitizing product (4), said slits having a maximum width of 2 mm that is such as to prevent the exit of the product in gel form (4) during the pouring of the product into said container body (2), said container body (2) being provided, at an upper surface thereof that is adapted to be directed, when installed, toward the opening of the sanitary fixture, with a plurality of walls (10) that are arranged mutually offset.
 3. The device according to claim 2 **characterized in that** said slits (5) are defined at the bottom surface of said container body (2).
 4. The device according to claim 2 **characterized in that** said slits (5) are defined at the bottom surface of said container body (2), with a central region (6) of the bottom surface of the container that is free of slits.
 5. The device according to claim 2 **characterized in that** the slits (5) widen at the edges of said container body (2).

Patentansprüche

1. Verfahren zum Füllen einer Desinfektionsvorrichtung (1), das die folgenden Schritte umfasst:
 - Vorbereiten eines Behälterkörpers (2) zum Aufnehmen eines Desinfektionsprodukts in Gelform (4), wobei der Behälterkörper (2) mit Schlitz (5) versehen ist, die so geformt sind, dass sie eine allmähliche Freisetzung des Desinfektionsprodukts (4) zulassen, wobei die Schlitz (5) eine maximale Breite von 2 mm aufweisen, die so beschaffen ist, dass sie den Austritt des Produkts in Gelform (4) während des Füllens des Produkts in Gelform in den Behälterkörper (2) verhindert; der Behälterkörper (2) ist an einer Oberseite, die im eingebauten Zustand auf die

Öffnung der Sanitärarmatur gerichtet werden kann, mit mehreren Wänden (10) versehen, die gegeneinander versetzt angeordnet sind;

- Erwärmen eines Produkts in Gelform (4), wobei die Erwärmungstemperatur, auf die das Produkt in Gelform erwärmt wird, so beschaffen sein muss, dass das Gelprodukt zum Füllzeitpunkt eine Mindestviskosität von 500 mPa*s aufweist;
- Füllen des Produkts in Gelform (4) in den Behälterkörper (2), sodass das Produkt in Gelform (4) anfangs in Kontakt mit einem Bereich des Behälterkörpers (2) ohne Schlitz (5) oder mit Schlitz (5) mit einer maximalen Breite kommt, die so beschaffen ist, dass der Austritt des Produkts in Gelform (4) während des Füllens des Produkts in Gelform in den Behälterkörper (2) verhindert wird;
- das Produkt in Gelform (4) im Inneren des Behälterkörpers (2) expandieren zu lassen und beim Abkühlen eine Endviskosität von mindestens 50 Pa*s zu erreichen.

2. Desinfektionsvorrichtung (1), umfassend einen Behälterkörper (2), der ein Desinfektionsprodukt in Gelform (4) mit einer Viskosität von mindestens 50 Pa*s enthält, wobei der Behälterkörper (2) mit Schlitz (5) versehen ist, die so geformt sind, dass sie eine allmähliche Freisetzung des Desinfektionsprodukts (4) zulassen, wobei die Schlitz (5) eine maximale Breite von 2 mm aufweisen, die so beschaffen ist, dass der Austritt des Produkts in Gelform (4) während des Füllens des Produkts in Gelform in den Behälterkörper (2) verhindert wird, wobei der Behälterkörper (2) an seiner Oberseite, die im eingebauten Zustand auf die Öffnung der Sanitärarmatur gerichtet werden kann, mit mehreren Wänden (10) versehen ist, die gegeneinander versetzt angeordnet sind.
3. Vorrichtung nach Anspruch 2, **dadurch gekennzeichnet, dass** die Schlitz (5) an der Unterseite des Behälterkörpers (2) definiert sind.
4. Vorrichtung nach Anspruch 2, **dadurch gekennzeichnet, dass** die Schlitz (5) an der Unterseite des Behälterkörpers (2) definiert sind, mit einem zentralen Bereich (6) der Unterseite des Behälters, der frei von Schlitz (5) ist.
5. Vorrichtung nach Anspruch 2, **dadurch gekennzeichnet, dass** sich die Schlitz (5) an den Kanten des Behälterkörpers (2) aufweiten.

Revendications

1. Procédé de remplissage d'un dispositif de désinfection (1), comprenant les étapes consistant à :

- préparer un corps de récipient (2) pour qu'il contienne un produit de désinfection sous forme de gel (4), ledit corps de récipient (2) étant pourvu d'encoches (5) qui sont adaptées à permettre une libération graduelle dudit produit de désinfection (4), lesdites encoches (5) ayant une largeur maximum de 2 mm, de manière à empêcher la sortie du produit sous forme de gel (4) pendant le déversement dudit produit sous forme de gel dans ledit corps de récipient (2) ; ledit corps de récipient (2) est pourvu, au niveau de sa surface supérieure qui est adaptée à être orientée, une fois installée, vers l'ouverture de l'appareil sanitaire, d'une pluralité de parois (10) qui sont décalées les unes par rapport aux autres ;
- chauffer un produit sous forme de gel (4), la température de chauffage auquel le produit sous forme de gel est chauffé doit être telle qu'au moment du déversement, le produit en gel présente une viscosité minimum de 500 mPa*s ;
- déverser ledit produit sous forme de gel (4) dans ledit corps de récipient (2), de sorte que le produit sous forme de gel (4) vienne initialement en contact avec une région dudit corps de récipient (2) sans encoches ou avec des encoches (5) ayant une largeur maximum telle qu'elle empêche la sortie du produit sous forme de gel (4) pendant le déversement du produit sous forme de gel dans le corps de récipient (2) ;
- laisser le produit sous forme de gel (4) se dilater à l'intérieur dudit corps de récipient (2) et atteindre une viscosité finale avec refroidissement d'au moins 50 Pa*s.
2. Dispositif de désinfection (1) comprenant un corps de récipient (2) contenant un produit de désinfection sous forme de gel (4) ayant une viscosité d'au moins 50 Pa*s, ledit corps de récipient (2) étant pourvu d'encoches (5) qui sont adaptées à permettre la libération graduelle du produit de désinfection (4), lesdites encoches ayant une largeur maximum de 2 mm, de manière à empêcher la sortie du produit sous forme de gel (4) pendant le déversement du produit dans ledit corps de récipient (2), ledit corps de récipient (2) étant pourvu, au niveau de sa surface supérieure qui est adaptée à être orientée, une fois installée, vers l'ouverture de l'appareil sanitaire, d'une pluralité de parois (10) qui sont décalées les unes par rapport aux autres.
3. Dispositif selon la revendication 2, **caractérisé en ce que** lesdites encoches (5) sont définies au niveau de la surface de fond dudit corps de récipient (2).
4. Dispositif selon la revendication 2, **caractérisé en ce que** lesdites encoches (5) sont définies au niveau de la surface de fond dudit corps de récipient (2),
- une région centrale (6) de la surface de fond du récipient étant exempte d'encoches.
5. Dispositif selon la revendication 2, **caractérisé en ce que** les encoches (5) s'élargissent au niveau des bords dudit corps de récipient (2).

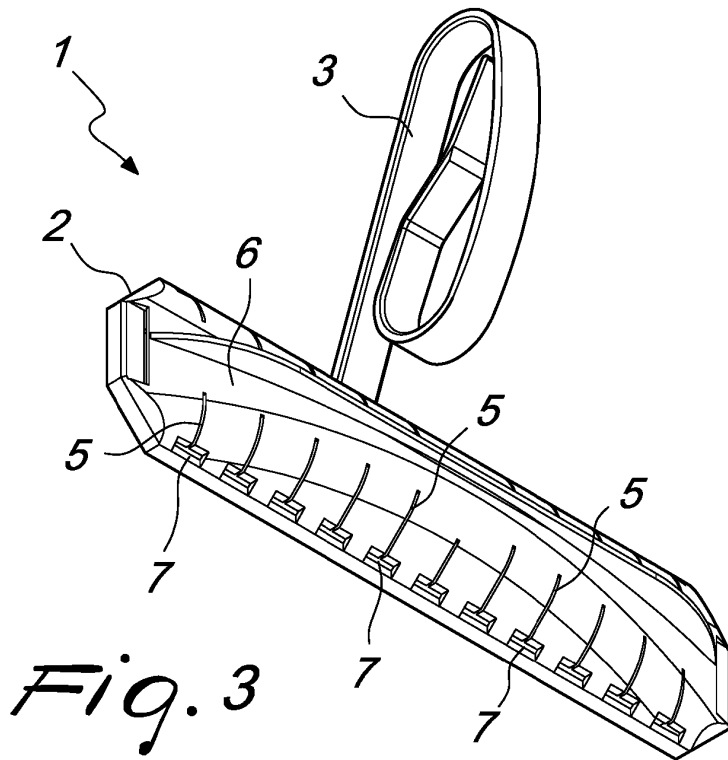
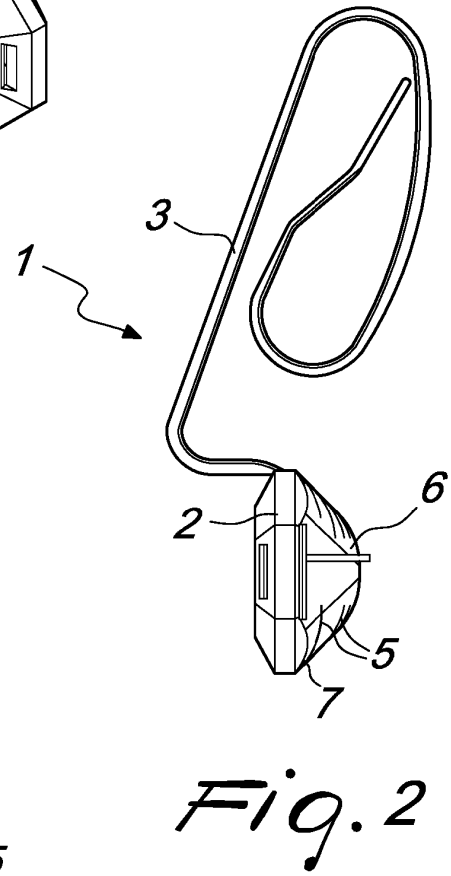
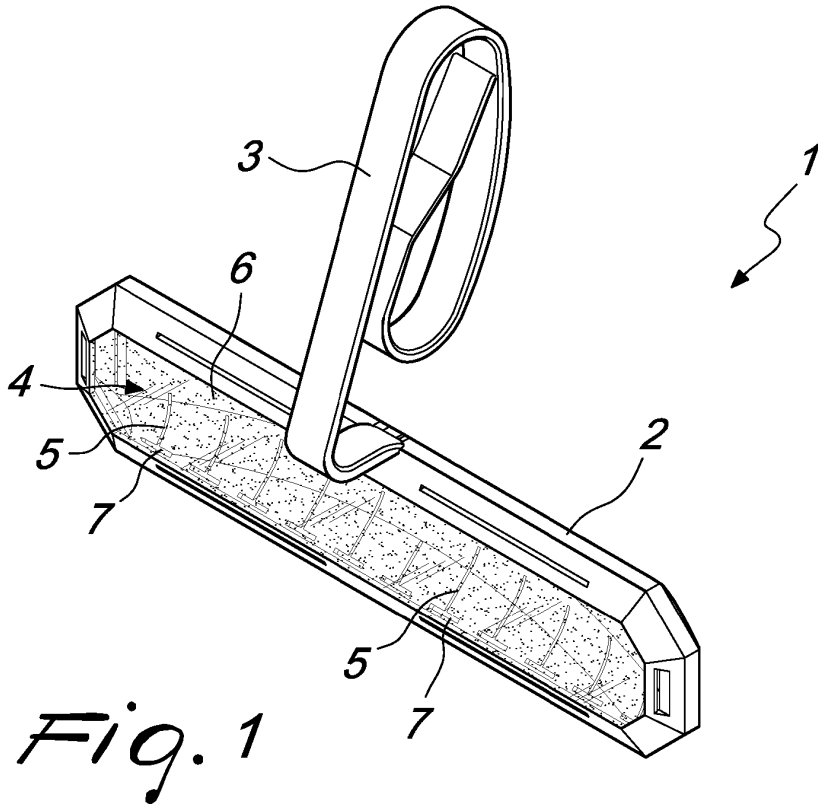

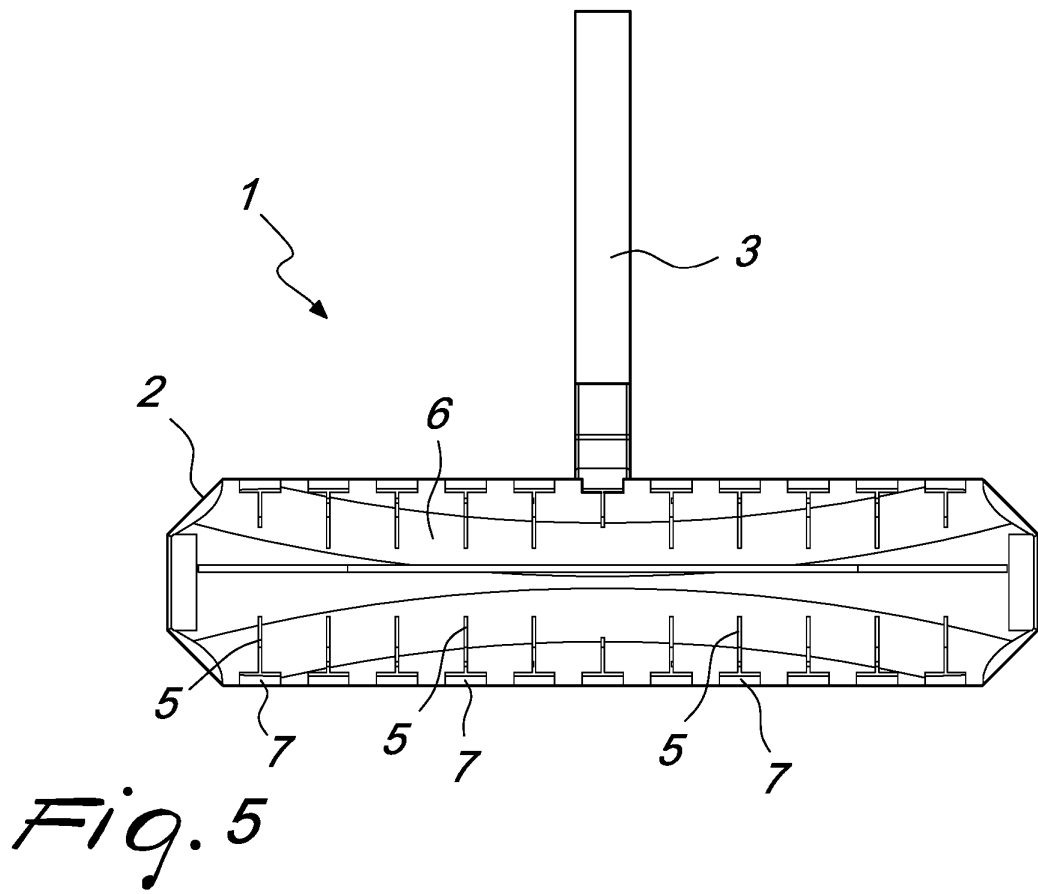
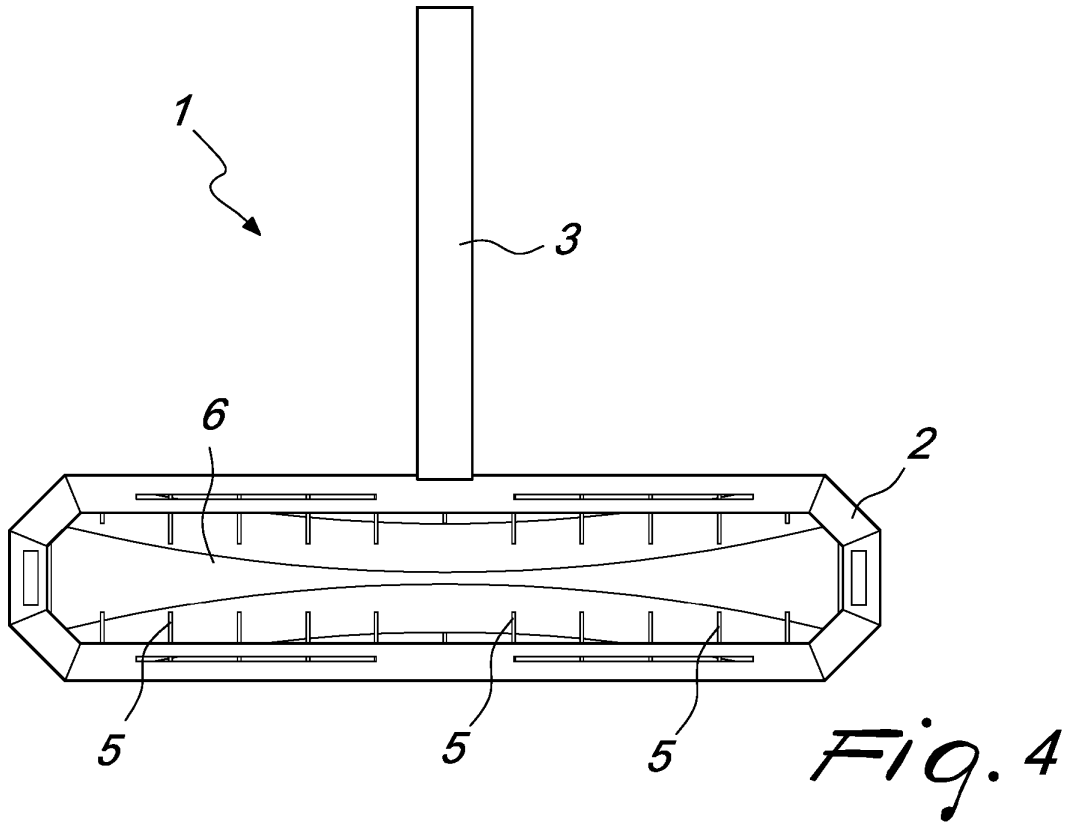

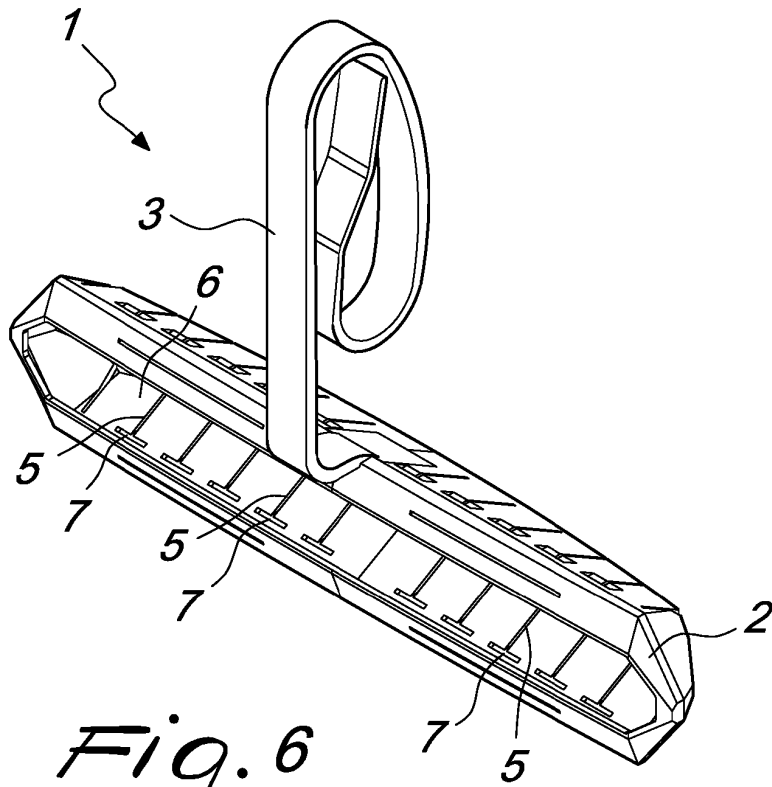

Fig. 6

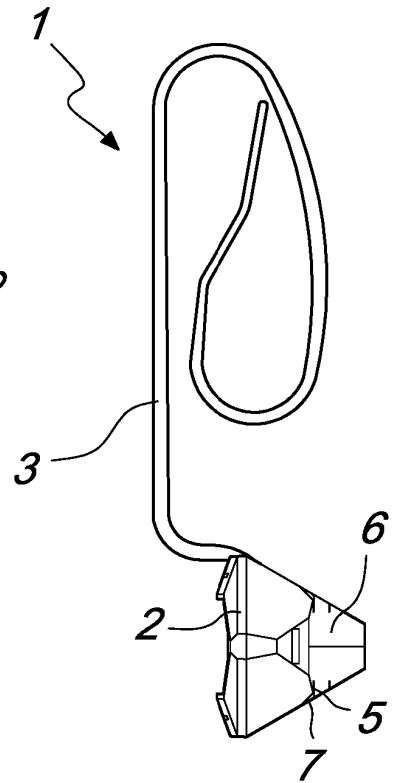

Fig. 7

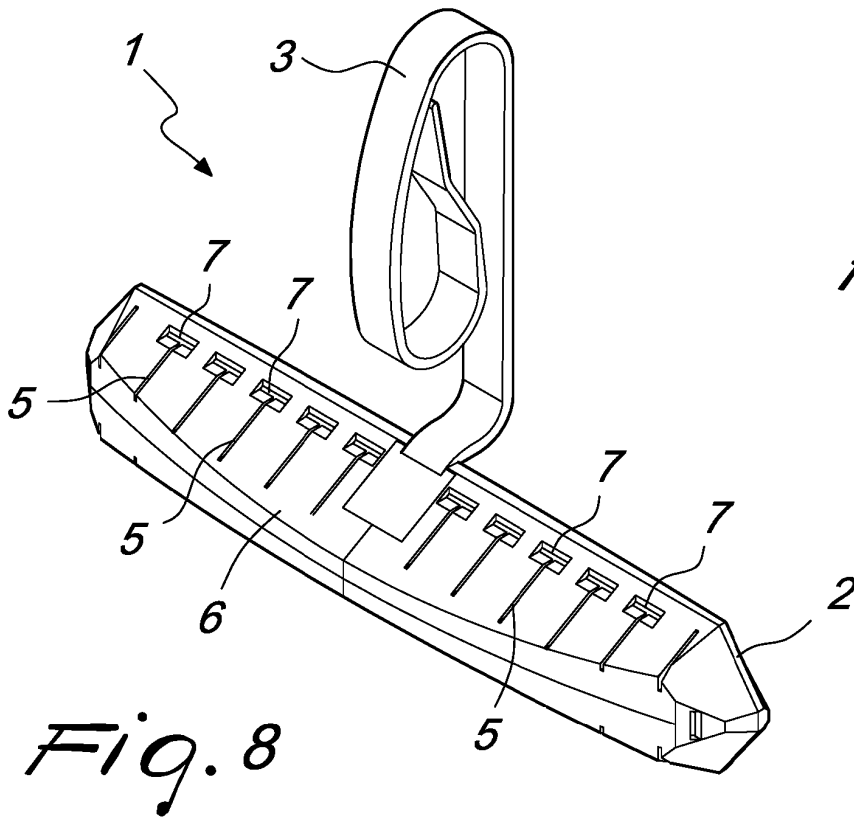
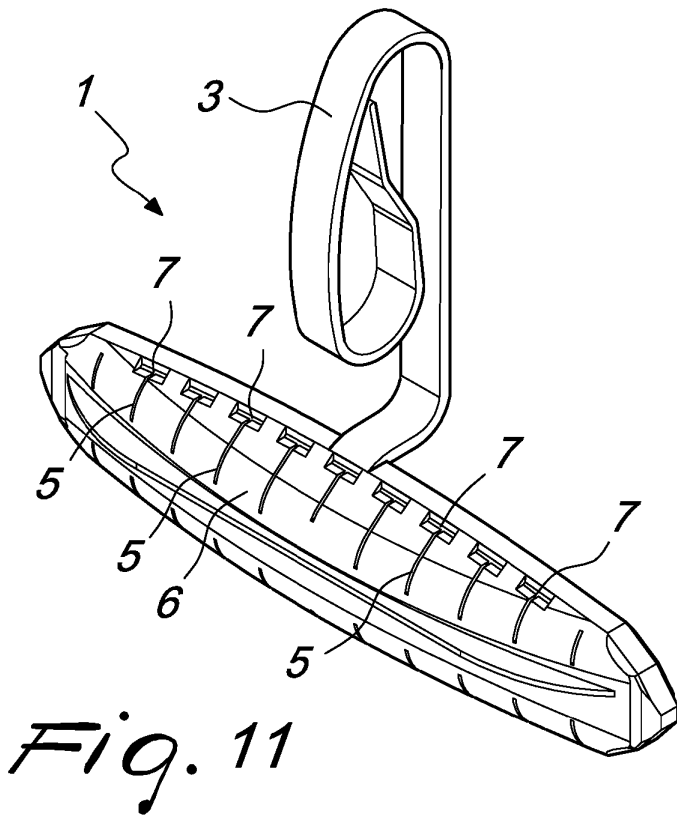
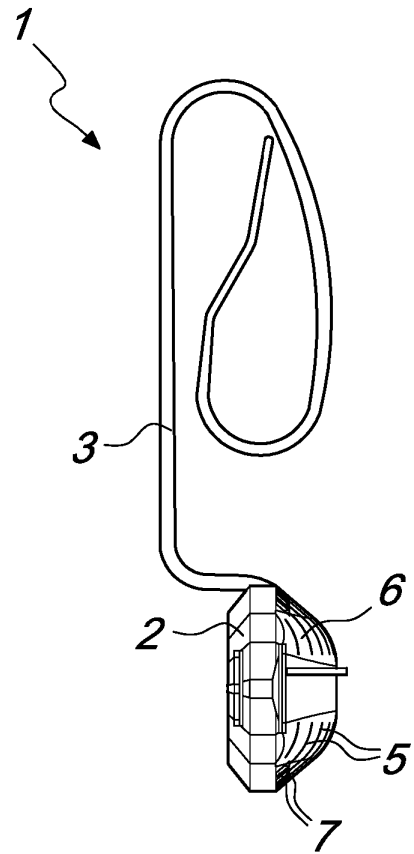
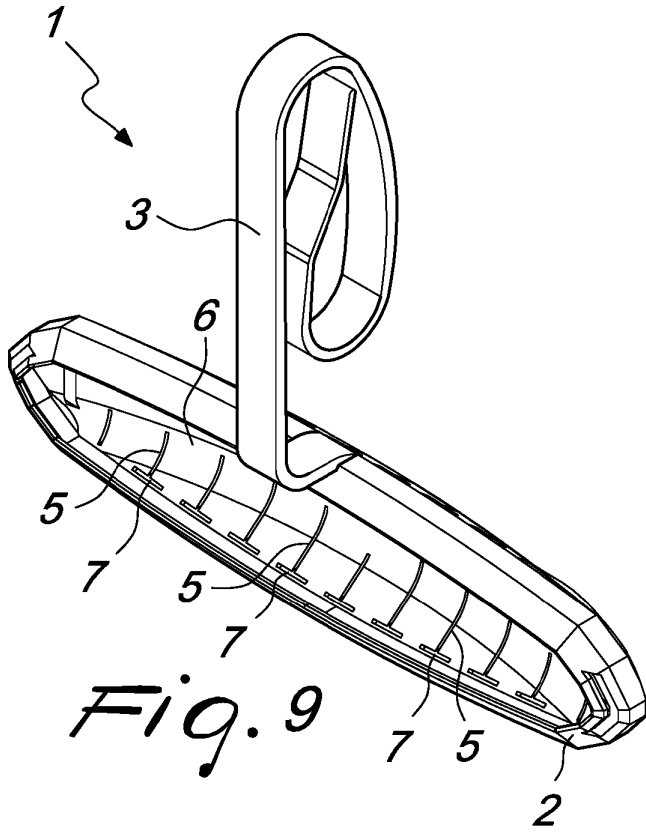
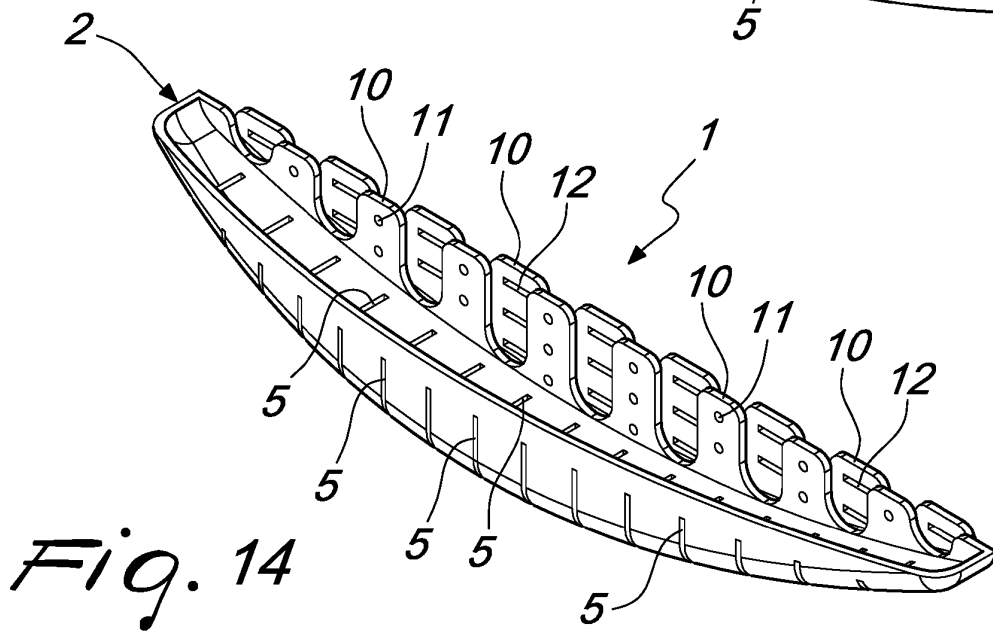
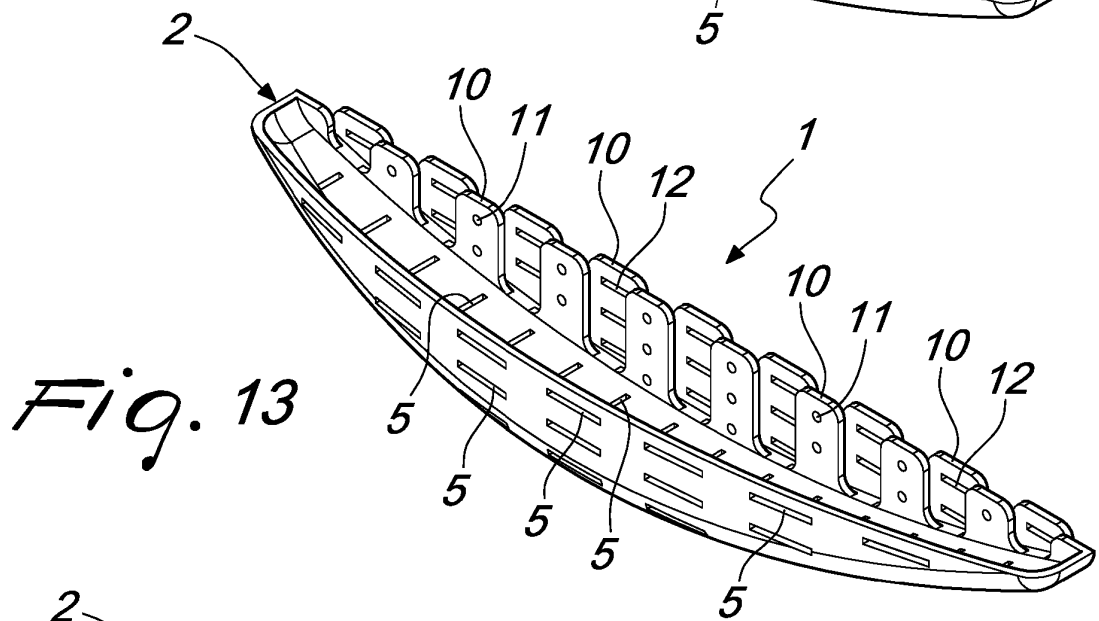
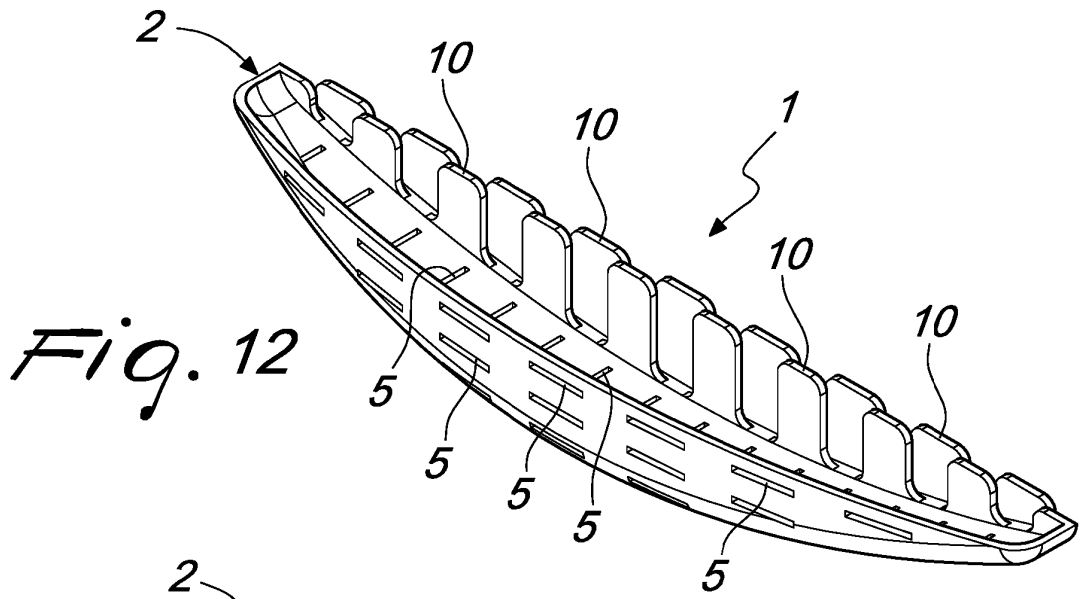

Fig. 8





REFERENCES CITED IN THE DESCRIPTION

This list of references cited by the applicant is for the reader's convenience only. It does not form part of the European patent document. Even though great care has been taken in compiling the references, errors or omissions cannot be excluded and the EPO disclaims all liability in this regard.

Patent documents cited in the description

- FR 2258320 A1 [0013]
- EP 0940509 A2 [0013]
- GB 2416785 A [0013]
- EP 2620489 A1 [0013]
- US 2010235976 A1 [0013]
- EP 1978080 A1 [0013]
- GB 2401791 A [0013]
- WO 2014031159 A1 [0013]
- GB 11185 A [0013]
- DE 10020090 A1 [0013]
- EP 2407601 A2 [0013]
- US 6505356 B1 [0013]
- FR 2258320 [0015]
- EP 0940509 A [0016]