



(86) Date de dépôt PCT/PCT Filing Date: 1999/11/16
(87) Date publication PCT/PCT Publication Date: 2000/05/25
(45) Date de délivrance/Issue Date: 2006/01/10
(85) Entrée phase nationale/National Entry: 2001/05/15
(86) N° demande PCT/PCT Application No.: CA 1999/001086
(87) N° publication PCT/PCT Publication No.: 2000/029644
(30) Priorité/Priority: 1998/11/17 (60/108,782) US

(51) Cl.Int.⁷/Int.Cl.⁷ C25C 3/08, C04B 35/52

(72) Inventeurs/Inventors:
MIRTCHI, AMIR A., CA;
BERGERON, JULES, CA

(73) Propriétaire/Owner:
ALCAN INTERNATIONAL LIMITED, CA

(74) Agent: KIRBY EADES GALE BAKER

(54) Titre : MATIERES COMPOSITES EN CARBONE MOUILLABLES ET RESISTANT A L'EROSION/OXYDATION
(54) Title: WETTABLE AND EROSION/OXIDATION-RESISTANT CARBON-COMPOSITE MATERIALS

(57) **Abrégé/Abstract:**

The process comprises mixing together finely divided quantities of TiO_2 and B_2O_3 (or other metal boride precursors) to produce a precursor mixture, and then mixing the precursor mixture with at least one carbon-containing component to produce a carbon composite material that forms TiB_2 (or other metal boride) in situ when exposed to molten aluminum or subjected to the heat of cell start-up and operation. The invention also relates to the carbon composite materials thus produced that may be used to form blocks (including side wall blocks) for the construction of cathode structures (or coatings for such blocks) or may be used to prepare joint-filling and coating compositions for use in aluminum reduction cells, or protective coatings for instruments used with molten metals.



PCT

WORLD INTELLECTUAL PROPERTY ORGANIZATION
International Bureau

INTERNATIONAL APPLICATION PUBLISHED UNDER THE PATENT COOPERATION TREATY (PCT)

(51) International Patent Classification ⁷ : C25C 3/08, C04B 35/52	A1	(11) International Publication Number: WO 00/29644 (43) International Publication Date: 25 May 2000 (25.05.00)
<p>(21) International Application Number: PCT/CA99/01086</p> <p>(22) International Filing Date: 16 November 1999 (16.11.99)</p> <p>(30) Priority Data: 60/108,782 17 November 1998 (17.11.98) US</p> <p>(71) Applicant (for all designated States except US): ALCAN INTERNATIONAL LIMITED [CA/CA]; 1188 Sherbrooke Street West, Montreal, Québec H3A 3G2 (CA).</p> <p>(72) Inventors; and (75) Inventors/Applicants (for US only): MIRTCHI, Amir, A. [CA/CA]; 2395 Dieppe Street, Jonquiere, Québec G7S 5N3 (CA). BERGERON, Jules [CA/CA]; 4013 Des Hérons Street, Jonquiere, Québec G7X 9B6 (CA).</p> <p>(74) Agents: GALE, Edwin, J. et al.; Kirby, Eades, Gale, Baker, Box 3432, Station D, Ottawa, Ontario K1P 6N9 (CA).</p>	<p>(81) Designated States: AE, AL, AM, AT, AU, AZ, BA, BB, BG, BR, BY, CA, CH, CN, CR, CU, CZ, DE, DK, DM, EE, ES, FI, GB, GD, GE, GH, GM, HR, HU, ID, IL, IN, IS, JP, KE, KG, KP, KR, KZ, LC, LK, LR, LS, LT, LU, LV, MA, MD, MG, MK, MN, MW, MX, NO, NZ, PL, PT, RO, RU, SD, SE, SG, SI, SK, SL, TJ, TM, TR, TT, TZ, UA, UG, US, UZ, VN, YU, ZA, ZW, ARIPO patent (GH, GM, KE, LS, MW, SD, SL, SZ, TZ, UG, ZW), Eurasian patent (AM, AZ, BY, KG, KZ, MD, RU, TJ, TM), European patent (AT, BE, CH, CY, DE, DK, ES, FI, FR, GB, GR, IE, IT, LU, MC, NL, PT, SE), OAPI patent (BF, BJ, CF, CG, CI, CM, GA, GN, GW, ML, MR, NE, SN, TD, TG).</p> <p>Published With international search report.</p>	
(54) Title: WETTABLE AND EROSION/OXIDATION-RESISTANT CARBON-COMPOSITE MATERIALS		
(57) Abstract		
<p>The process comprises mixing together finely divided quantities of TiO₂ and B₂O₃ (or other metal boride precursors) to produce a precursor mixture, and then mixing the precursor mixture with at least one carbon-containing component to produce a carbon composite material that forms TiB₂ (or other metal boride) <i>in situ</i> when exposed to molten aluminum or subjected to the heat of cell start-up and operation. The invention also relates to the carbon composite materials thus produced that may be used to form blocks (including side wall blocks) for the construction of cathode structures (or coatings for such blocks) or may be used to prepare joint-filling and coating compositions for use in aluminum reduction cells, or protective coatings for instruments used with molten metals.</p>		

WO 00/29644

PCT/CA99/01086

1

WETTABLE AND EROSION/OXIDATION-RESISTANT CARBON-COMPOSITE
MATERIALS

TECHNICAL FIELD

5

This invention relates to carbon-composite materials, particularly of the type used to form cathodes or cell linings of electrolysis reduction cells, especially those used for the production of aluminum metal, as well as
10 parts of such cathodes and linings, and related products. More particularly, the invention relates to carbon composite materials that are erosion/oxidation-resistant and, desirably, that are wettable by molten aluminum.

15 BACKGROUND ART

The cathodes of cells used for the production of aluminum generally take the form of a lining made of carbon blocks, or the like, positioned along the bottom wall and
20 sides of an electrolysis cell. A typical electrolysis cell 10 is shown in Figs. 1 and 2 of the accompanying drawings. Where the surface 11 of the molten electrolyte 12 contacts the sidewalls 14 of the cell, the cathode 15 is often sloped as shown (this usually being referred to
25 as the "monolithic slope" of the cell lining) to reduce cell erosion caused by magneto-hydrodynamic (MHD) effects that may create excessive metal motion. Conductive anodes (not shown) dip into the molten electrolyte from above to complete the electrode combination required for
30 electrolysis. The cathodic lining 16 is conductive and contacts the molten electrolyte 12 and also the pool 17 of molten metal as it is formed. Gaps 18 between the

blocks 20 used to form the cathodic cell lining, and wider gaps between the bottom blocks 20 and sidewall blocks 25, are usually filled with a conductive cathode paste 21 (referred to as a ramming mix) that hardens when
5 the cell 10 is heated during start-up. All of the materials used for these purposes should desirably be electrically conductive, refractory and also erosion resistant to reduce physical removal caused by flow of electrolyte past the surface of the material, as well as
10 being corrosion resistant (i.e. able to withstand chemical attack).

In one form of the electrolysis cell, the cathode surface at the bottom of the cell slopes slightly downwardly
15 towards a well or reservoir (not shown in the drawings) so that molten aluminum, as it is formed between the anode and cathode surfaces, drains off the cathode surface into the metal reservoir where it can be tapped from the cell. Cells of this kind are referred to as
20 "drained cathode cells" and their advantage is that short interpolar distances can be employed to achieve a high current efficiency. For such cells to work properly, however, the cathode surface must be wettable by the molten metal so that a thin layer of metal covers the
25 cathode surface at all times. Anthracite and graphite blocks, and other carbonaceous materials generally used for cathode formation in conventional cells, are not wettable by molten aluminum. Attempts have therefore been made to find materials that are wettable by aluminum
30 and that may be used to form cathodes.

According to US patent 3,400,061 to R.A. Lewis et al., issued September 3, 1968, wettable cathode surfaces can be formed from a composite cathode material comprising a mixture of refractory hard substance and at least about 5% carbon. Powdered titanium boride (TiB_2) has been a preferred refractory hard material for such applications, although other ceramic powders such as silicon carbide, alumina, etc., may also be used. The carbon component is often anthracite with coal tar pitch as a binder.

10

TiB_2 is also used in admixture with carbon components to form erosion-resistant ramming pastes for all kinds of cells. Generally, lower contents of TiB_2 are required to improve erosion resistance alone, than to achieve both erosion resistance and surface wettability. Such pastes are often used to fill in the central joint and the small joint of cathodic linings and for filling exposed areas of the monolithic slope.

15

Although titanium boride is preferred from the point of view of superior performance, it has the considerable disadvantage that it is very expensive. At present, for example, the cost of TiB_2 is approximately CDN\$66,180 per metric ton (approximately CDN\$60,000 per ton).

25

US patent 5,158,655 to Townsend issued on October 27, 1992 has suggested that cathode structures may be coated with refractory metal borides from oxides of titanium and boron added directly to the cell electrolyte or contained in the anodes. However, tests of this proposal carried out by the inventors of the present invention have

30

demonstrated the difficulty of producing an acceptable product in this way.

PCT patent publication WO 82/01018 which published on
5 April 1, 1982 in the name of Great Lakes Carbon
Corporation discloses a cathode component for a Hall
aluminum cell that is economically produced from a
mixture of a carbon source, a binder, titanium dioxide,
and a boron compound. The mixture is formed into a
10 shape and heated at TiB_2 -forming temperatures.
However, the inventors of the present invention have
found that the reaction will not go to completion at
standard bake temperatures in a furnace under oxidizing
conditions, and very high temperatures have to be
15 employed.

PCT patent publication no WO 94/21572 which published
on September 29, 1994 in the name of Moltech Invent
. S.A. discloses a method of producing a component of an
20 aluminum production cell made of a carbon-based
composite material containing a refractory hard metal
boride, carbide, oxide, nitride or combinations or
mixtures thereof, and aluminium, titanium, silicon and
zirconium, and alloys and compounds thereof. This is
25 produced by first providing a reaction mixture of
aluminium, titanium, silicon or zirconium and
precursors which react to form the refractory hard
metal compound, and optional fillers and additives.
The reaction mixture is mixed with particulate carbon
30 and a binder, compacted, dried and heated to initiate
reaction of the reaction mixture. However, this is a
complicated mixture to produce and requires the

4/1

presence of metal powder in stoichiometrical amounts to drive the reaction to completion.

There is therefore a need for a way of producing
5 erosion- and preferably oxidation-resistant and optionally wettable carbon composite materials (e.g. useful for making bottom and side wall blocks and ramming pastes of electrolysis cells) that are less expensive than known boride-containing materials, but
10 suitably effective for use in electrolysis cells, and particularly in drained cathode cells.

DISCLOSURE OF THE INVENTION

15 An object of the invention is to provide carbon composite materials, which may be fashioned as cathode blocks, jointing pastes, or the like, that are erosion/oxidation resistant and preferably wettable by molten aluminum when used in electrolysis cells, while
20 being relatively inexpensive and easy to produce.

Another object is to reduce the cost of operation of electrolysis cells, especially drained cathode cells, without sacrificing performance significantly.
25

Another object is to provide relatively inexpensive carbon composite materials that may be used to protect devices intended to be immersed in molten metals.

30 The present invention is based on the unexpected finding that, instead of using a metal boride, e.g. TiB₂, as a _____

refractory hard substance for the preparation of cathode materials, and the like, the metal boride can be formed *in situ* when subjected to the heat of cell start-up and to cell operation by providing a mixture of metal boride precursors in admixture together with a carbonaceous material.

Such precursor mixtures are generally mixtures of boron oxide (B_2O_3), boric acid (H_3BO_3) or borax ($Na_2O \cdot 2B_2O_3 \cdot 10H_2O$) with one or more metal oxides. Examples of suitable metal oxides include, but are not necessarily limited to, titanium dioxide, zirconium oxide, vanadium oxide (V_2O_5 and V_2O_3), hafnium oxide, niobium oxide, tantalum oxide, chromium oxide and molybdenum oxide. On reaction with boron oxide, boric acid, or borax, these metal oxides form the corresponding metal boride.

The cost of such metal oxides and boron oxides (in boric acid form) is about one thirtieth of the cost of equal amounts of the metal borides, e.g. TiB_2 . However, since the metal borides are present in the cathode material when the cell is operated, there is substantially no difference in erosion/oxidation resistance and wettability compared to cathodes prepared from the metal boride as a starting material, or at least the performance is commercially acceptable.

However, in order to make the *in situ* formation of the metal boride from the precursors proceed suitably to completion, the precursor materials must be mixed together before they are mixed with the other components

(anthracite, pitch or tar) of the cathodic materials. If they are mixed separately with the other materials, adequate metal boride formation does not take place.

5 Thus, according to one aspect of the invention, there is provided a process of producing a carbon composite material suitable for use in preparing all or part of a cathode or cell lining, including side wall block, of an aluminum electrolysis cell, which process comprises:
10 mixing together quantities of precursors of a metal boride to produce a precursor mixture, and then mixing said precursor mixture with at least one carbon-containing component to form said carbon composite material; wherein said precursors react together to
15 generate said metal boride *in situ* when said material is exposed to start-up and operation of said cell.

The precursor oxides used to form the precursor mixture are preferably finely divided. By the term "finely
20 divided" we mean powders having average particle sizes sufficiently small to allow effective reaction of the precursors during cell start-up to produce corresponding metal borides.

25 According to another aspect of the invention, there is provided a carbon composite material suitable for use in preparing all or part of a cathode or cell lining,

including side wall block, of an aluminum electrolysis cell, said material comprising finely divided quantities of precursors of a metal boride and at least one carbon-containing component; wherein said precursors react
5 together to generate said metal boride *in situ* when said material is exposed to start-up and operation of said cell.

According to yet another aspect of the invention, there
10 is provided a carbon composite material suitable for immersion in molten aluminum, the material comprising finely divided quantities of precursors of a metal boride and at least one carbon-containing component to form the carbon composite material; wherein said precursors react
15 together to generate said metal boride *in situ* when said material exposed to molten aluminum.

In contrast to the CDN\$66,180 per metric ton (CDN\$60,000 per ton) mentioned above as the cost of TiB_2 , an
20 equivalent amount of a precursor oxide mixture currently costs in the region of CDN\$2,206 per metric ton (CDN\$2,000 per ton). The cost savings achievable by the present invention is clearly significant. When the invention is used to form wettable cathodes for drained
25 cathode cells, the economic advantage obtained during the preparation of aluminum, compared to the use of blocks prepared from TiB_2 , has proven to be about CND\$66 per metric ton of metal (CND\$60 per ton of metal).

30 Because of the high cost of TiB_2 , it has become common merely to apply the material merely in the form of

ceramic tiles or as a coating to the exposed surfaces of conventional carbon blocks. The tiles, which can be up to 5 cm in thickness, have been attached via adhesive compounds, whereas the coatings (generally less than 1 cm thick) have traditionally been plasma sprayed onto the block surfaces. Unfortunately, differences in rates of thermal expansion often cause the aforementioned tiles and coatings to crack and separate from the underlying cathode material, thus reducing the effective life of the cell. It is a particular advantage of the present invention that, because of the reduction of cost of the raw materials, the composite material of the present invention may be used to form entire cathode blocks, thus prolonging the effective life of the cell significantly. Alternatively, the composite materials may be used as surface coatings in the same way as the conventional material, but at considerably lower cost.

An advantage of the material produced according to the present invention is that it is not only more erosion-resistant than graphite or anthracite blocks, but also tends to be more oxidation resistant for side wall block, and thus has a longer effective life.

At least in preferred forms, the composites of the present invention can usually achieve a contact angle with molten aluminum of less than about 45° , and an erosion/oxidation rate of less than 5 mm/year during normal use in an electrolysis cell (compared to more than 10 mm/year for conventional cathode material).

BRIEF DESCRIPTION OF THE DRAWINGS

Fig. 1 is a perspective view, with a part cut away, of a conventional aluminum electrolysis cell with which the present invention may be used, and from which the electrolyte, molten aluminum and anodes have been omitted for clarity; and

Fig. 2 is a partial transverse cross-section of the cell of Fig. 1 on an enlarged scale showing the molten electrolyte and aluminum.

BEST MODES FOR CARRYING OUT THE INVENTION

The present invention encompasses at least two main kinds of material, i.e. jointing compounds used for filling gaps between elements used to form a cathode (including side wall blocks), and the cathode elements themselves, e.g. cathode blocks used to construct the cathode lining of a cell such as the one shown in Figs. 1 and 2. Moreover, the material may be primarily of enhanced erosion/oxidation resistance compared to carbon (e.g. for use in conventional cells that are not self-draining) or of both enhanced erosion/oxidation resistance and also having a surface (when baked) that is wettable with molten aluminum. In all of these cases, of course, the material is prepared by first mixing a metal oxide and boron oxide (or boron acid precursors, e.g. boric acid or borax) to form an oxide mixture, and then mixing the oxide mixture with carbonaceous components.

For enhanced erosion/oxidation resistance alone, a lower concentration of the metal boride precursors is normally required than if both erosion resistance and wettability are required. For erosion resistance alone, at least
5 when precursors for TiB_2 and VB_2 are employed, a minimum of 5% by weight of the precursors (calculated as the metal boride) is required. To produce a material having a wettable surface, a minimum concentration of about 30% by weight is required.

10

With regard to the metal oxide and boron oxide, it is preferable to start with powders of each having an average particle size of less than about 100 microns (μm). Large particles may be used if desired, but
15 particles smaller than 30 μm tend to react more completely and more quickly since a more intimate mixture of the precursor oxides can be obtained.

The ratio in which the precursor oxides are mixed depends
20 on the identity of the precursors, the intention being to convert all of the precursors into the final metal borides (i.e. generally stoichiometric quantities). In the case of TiO_2 and B_2O_3 (or H_3BO_3), the preferred ratio is 40-50/50-60 by weight, respectively. The oxide
25 precursors may be mixed together at ambient temperature for convenience, although any temperature may be employed, provided reaction between the precursors is not commenced prematurely.

30 The oxide mixture is then mixed with carbonaceous ingredients suitable to prepare cathode components, e.g.

a mixture of anthracite and pitch. Usually, this mixing step is carried out at an elevated temperature, preferably about 160°C, to increase the fluidity of the carbonaceous components and therefore to make the mixing
5 step possible and convenient. The mixing ratio of the oxide mixture to the carbonaceous ingredients, and the choice of those ingredients, depends on the intended end use of the material. Generally, however, the oxide mixture may be mixed with a conventional anthracite/pitch
10 mixture in a ratio of 30-60/40-70 by weight, respectively. Also, to increase the kinetic of TiB_2 formation during cell operation, it is preferable to add a certain amount of TiB_2 powder (e.g. 3%-10% by weight) preferably with particle sizes smaller than 15 μ m in the
15 paste during mixing.

As well as the oxide precursors and carbonaceous material, the materials of the present invention may contain other conventional components and ingredients, as
20 required. The anthracite may be partially replaced by graphite to increase the electrical conductivity of composite material.

When the material is to be used for the preparation of
25 cathode blocks, the mixture is formed into blocks in a press (in which the material is vibrated as it is compressed), then the blocks are pre-baked prior to being inserted into a cell.

30 The exposure to cell start-up and operating temperatures (usually in the range of 600 - 1100°C, more usually about

700 - 1000°C), causes the precursor mixture to react to form the corresponding metal borides. It is also believed that the electrolysis reaction that takes place in the cell aids the formation of the metal boride and helps to drive the reaction of the precursors to completion. In fact, the electrolysis reaction may be essential to cause the formation of significant quantities of the metal boride, at least when the boride is TiB_2 .

10

The following description relates to the use of TiO_2 and B_2O_3 as precursors of TiB_2 .

The TiO_2 and B_2O_3 (or H_3BO_3) are preferably mixed together in stoichiometrical proportions for the formation of TiB_2 . This means about 70 parts by weight of TiO_2 for each part by weight of B_2O_3 . Of course, the relative amounts of these materials may differ from the stoichiometrical amounts, if desired. A difference of $\pm 30\%$ of TiO_2 from the stoichiometrical amount is generally acceptable without significant loss of performance.

As noted, the precursor materials should preferably be in the form of finely divided powders so that an intimate pre-mixing can be obtained. The average particle size of each powder should preferably not exceed 100 microns, and the average particle size of the powders should most preferably be in the range of 10 to 30 μm .

The precursor mixture of titanium boron oxides is then mixed with a carbonaceous material, usually anthracite

(with or without graphite) and a binder such as coal tar pitch. The ratio of precursor oxide mixture to carbonaceous material depends to some extent on the intended use of the final mixture (wetable cathode blocks, refractory joint paste, or the like), but is normally in the range of 40:60 parts by weight, more preferably 50:50 parts by weight. A certain amount of TiB_2 powder (e.g. 3%-10%) with particle size smaller than $15\mu m$ in the paste during mixing, could be added to the paste during mixing to increase the kinetic of TiB_2 formation during cell operation.

When the final mixture is intended for the production of wettable cathode blocks, the mixing ratio is more preferably 50:50 parts by weight (precursor oxide mixture:carbonaceous material). After thorough mixing, the paste is formed into blocks of a desired size and shape for cathode formation. The green blocks are then baked to a temperature in the range of 1000 to 1300°C in order to form self-supporting, dried blocks suitable for cathode construction.

When the final mixture is intended as a ramming paste, the mixing ratio of the oxide precursor mixture to the carbonaceous material is most preferably 50:50 parts by weight, and the paste is ready for use directly after thorough mixing. The paste is usually packaged in some form of airtight packaging to ensure that the paste does not dry out and lose its plasticity unduly. The paste may be used as a joint filler between the blocks used to form a cathode structure or may be used to coat a

conventional cathode structure in whole (or, more usually, in part) to provide erosion resistance. The monolithic side slope and central joint of the cell lining is a particular candidate for coating with the paste of the present invention because the joints between cathode blocks tend to erode relatively quickly at this location due to electrolyte movement. The paste of the present invention provides an erosion-resistant coating that prolongs the useful life of the cell.

10

Whatever way the cathodic material of the present invention is used, eventually it is subjected to the high temperatures of the electrolytic cell during cell start-up and operation. These temperatures normally fall into the range of 700 to 1000°C. These temperatures are high enough under electrolysis condition to drive the conversion of the oxide precursors to titanium diboride substantially to completion, according to the following formula:

20



In the above reaction, the presence of aluminum metal is not required for the reaction between the precursor components to go to completion, but the aluminum will obviously be present in certain parts of the cell and may take part in the reaction as shown. The reaction should, however, most preferably be carried out in a reducing environment, such as an electrolysis bath, in which the precursor oxides are converted to their non-oxide form.

30

As noted above, if the oxide precursors are not mixed together before being added to the carbonaceous material, titanium boride is not formed to the required extent. While the reason for this is not known with precision, it is believed that, during heating, the carbon forms a coating on each of the oxide precursor particles, thus interfering with the desired reaction.

While the materials of the present invention have been described primarily for use in the formation or protection of cathode linings, and side wall block, the materials may, in fact, be used for many other purposes in which there is exposure to molten metal, particularly aluminum, or molten electrolytes. For example, the material may be used to protect instruments that come into contact with molten aluminum, e.g. temperature sensors and probes (thermocouples) and the like, that have to be immersed in aluminum electrolysis cells and molten metal baths in general. The material may be used to form protective hollow sheaths for such instruments, or may be coated on metal housings or the like.

The invention is illustrated in more detail with reference to the following Examples, which are provided for the purpose of illustration only.

EXAMPLE 1: Bottom and side wall blocks

Composition:

Anthracite = 31 wt% by weight
TiO₂ = 20 wt%

$B_2O_3 = 30 \text{ wt}\%$

Pitch = 19 wt%

Fabrication (laboratory)

5

Mixing temperature: 160 °C

Mixing time: \approx 60 min.

Vibration time: 1 min.

Pressure on the top of the block: \approx 41.36856 kPa

10

(6 PSI)

Lab. Block dimension: 100 mm x 100 mm x 400 mm

15

The TiO_2 and B_2O_3 were pre-mixed and then mixed with the anthracite and pitch at a temperature of about 160°C for 60 min. To this paste was added about 3-10% by weight of TiB_2 powder. The hot paste was transferred after mixing to a mould fixed on a vibrated table. The vibrated blocks were baked at about 1200°C for 5 hours.

20

EXAMPLE 2: Ramming paste

Two formulations of a composite paste for potlining use were formulated as follows (percentages are by weight):

25

(A) Hot Potlining Paste (paste 100°C)

Anthracite = 35% by weight

$TiO_2 = 20\%$

$B_2O_3 = 30\%$

30

Pitch = 12%

Tar = 3%

The TiO_2 and B_2O_3 were pre-mixed and then mixed with the anthracite and pitch at a temperature of 120 - 130°C for 45 minutes. To this paste was added about 3-10% by weight of TiB_2 powder, and it was used in the cell at 100°C.

(B) Cold Potlining Paste (paste 30 °C)

10 Anthracite = 31% by weight
 TiO_2 = 20%
 B_2O_3 = 30%
 Pitch = 12%
 Light Oil = 7%

15

The TiO_2 and B_2O_3 (or H_3BO_3) were pre-mixed and then mixed with the anthracite, pitch and light oil at a temperature of 25-35°C for 45 minutes. To this mixture was added about 3-10% by weight of TiB_2 . This paste was used in the cell at 25-30°C.

When subjected to temperatures in the range of 700-1000°C during cell operation, both pastes were converted to solid composite materials containing TiB_2 of high abrasion resistance.

25

EXAMPLE 3

Electrolysis tests lasting about 100 hours were carried out on composite samples of carbon- TiO_2 - B_2O_3 . After 24 hours of electrolysis, there was observed the formation

30

of an aluminum layer on the composite sample that was polarized cathodic. During this experience, it was observed that the kinetic of TiB_2 formation on the surface of the carbon sample increased by using a small quantity of TiB_2 in the sample before forming and baking.

Electrolysis condition:

Al_2O_3 = 6% by weight
10 AlF_3 = 6% by weight
 CaF_2 = 6% by weight
Ratio (AlF_3/NaF) = 1.25
ACD = 3cm
Bath temperature = 970°C
15 Cathode current density = 1 amp/cm².

CLAIMS:

1. A process of producing a carbon composite material that in use in a cathode or cell lining of an aluminum electrolysis cell contains a metal boride, in which a
5 metal boride component is introduced into a carbonaceous component to form a carbon composite material, characterized in that the metal boride component is introduced into the carbonaceous component by admixture in the form of a metal boride precursor mixture, the metal
10 boride precursor mixture containing metal boride precursors that generate metal boride when exposed in the carbonaceous component to start-up and operation conditions of an aluminum electrolysis cell.
2. A process according to claim 1, characterized in that
15 an amount of said metal boride is added to said carbon composite material, said amount being in the range of 3 to 10% by weight of said carbon composite material.
3. A process according to claim 1 or 2, characterized in that one of said precursors used to form said precursor
20 mixture is selected from the group consisting of boron oxide, boric acid and borax, and another is an oxide of a metal selected from titanium, zirconium, vanadium, hafnium, niobium, tantalum, chromium and molybdenum.
4. A process according to claim 1 or 2, characterized in
25 that one of said precursors used to form said precursor mixture is selected from B_2O_3 and boric acid, and another is TiO_2 .

5. A process according to claim 1 or 2, characterized in that one of said precursors used to form said precursor mixture is selected from B_2O_3 and boric acid, and another is selected from V_2O_5 and V_2O_3 .
- 5 6. A process according to any one of claims 1 to 5, characterized in that said precursor mixture is mixed with said at least one carbonaceous component in an amount that generates said metal boride in a quantity forming at least 5% by weight of said carbon composite material after
10 exposure to said cell start-up and operation.
7. A process according to any one of claims 1 to 6, characterized in that said precursor mixture is mixed with said at least one carbonaceous component in an amount that generates a quantity of said metal boride, after exposure
15 to said cell start-up and operation conditions, making surfaces of said material wettable by molten aluminum.
8. A process according to claim 7, characterized in that said quantity is at least about 30% by weight of said carbon composite material.
- 20 9. A process according to any one of claims 1 to 3, characterized in that said at least one carbonaceous component is a mixture of anthracite and pitch.
10. A process according to any one of claims 1 to 9, characterized in that said precursors are in the form of
25 powders having an average particle size of less than 100 μm .
11. A process according to any one of claims 1 to 10, characterized by compressing the material to form a block, and pre-baking the block.

12. A process according to claim 11, characterized in that the block is pre-baked at a temperature in the range of 1000-1300°C.

13. A carbon composite material suitable for use in
5 preparing all or part of a cathode or cell lining,
including a side wall block, of an aluminum electrolysis
cell, said material comprising a metal boride component
and at least one carbon-containing component;
characterized in that said metal boride component
10 comprises metal boride precursors that react together to
generate said metal boride *in situ* when said carbon
composite material is exposed to start-up and operation
conditions of an aluminum electrolysis cell.

14. A material according to claim 13, characterized in
15 that one of said precursors is selected from the group
consisting of B₂O₃ and boric acid, and another is TiO₂.

15. A material according to claim 13, characterized in
that one of said precursors is selected from the group
consisting of B₂O₃ and boric acid, and another is selected
20 from the group consisting of V₂O₅ and V₂O₃.

16. A material according to any one of claims 13, 14 or
15, characterized in that said precursors are present in
an amount that generates said metal boride in a quantity
forming at least 5% by weight of said material after
25 exposure to electrolysis cell start-up and operation.

17. A material according to any one of claims 13 to 16,
characterized in that said precursors are present in an
amount that generates a quantity of said metal boride
making surfaces of said material, after exposure to

electrolysis cell start-up and operation, wettable by molten aluminum.

18. A material according to claim 17, characterized in that said quantity is at least about 30% by weight of said material.

19. A material according to any one of claims 13 to 18, wherein said precursors are in the form of powders having an average particle size of less than 100 μm .

20. A carbon composite material suitable for immersion in molten aluminum, said material comprising finely divided quantities of precursors of a metal boride and at least one carbon-containing component to form said carbon composite material; characterized in that said precursors react together to generate said metal boride *in situ* when said material is exposed to molten aluminum.

1/1

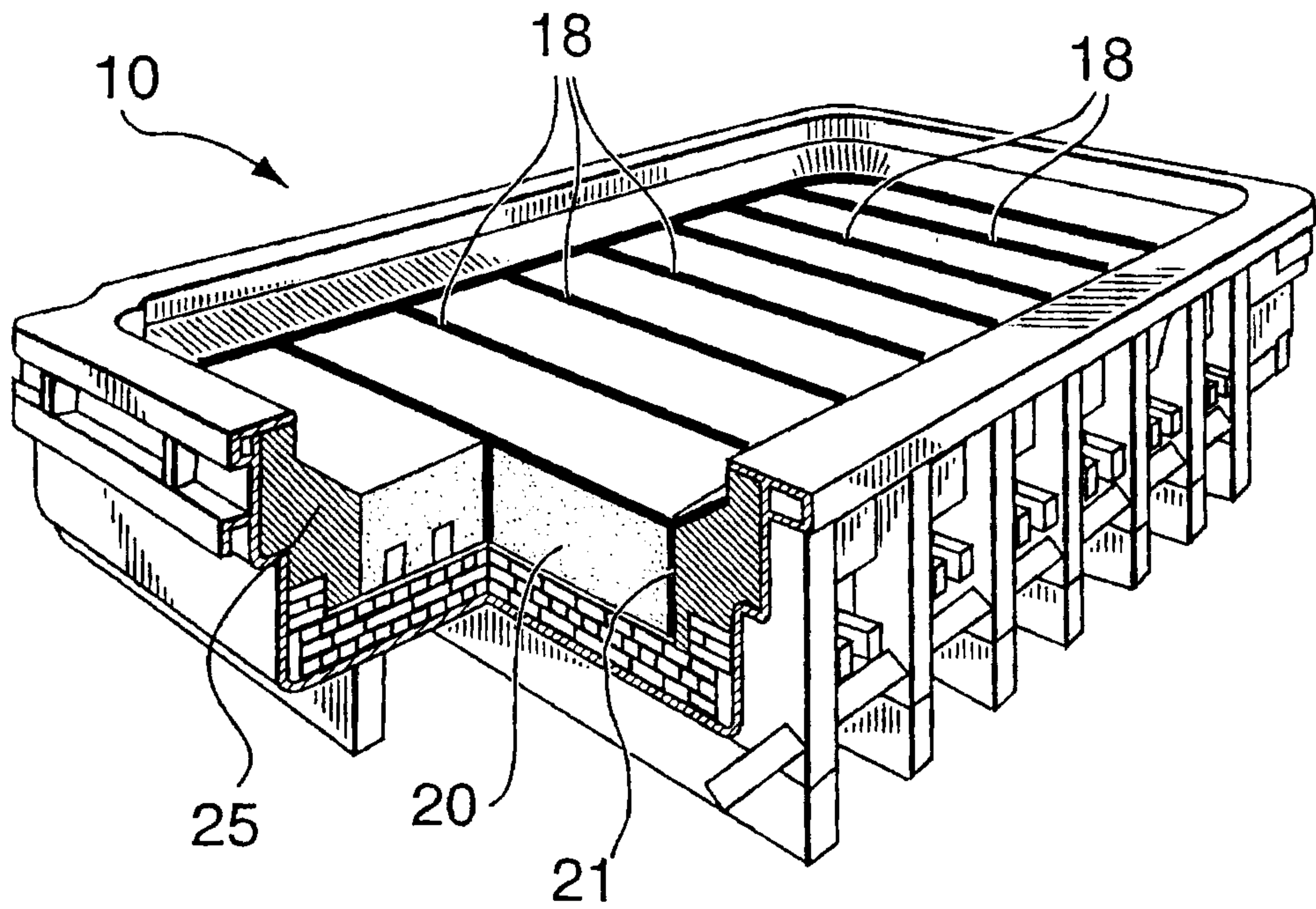

FIG. 1 (Prior Art)

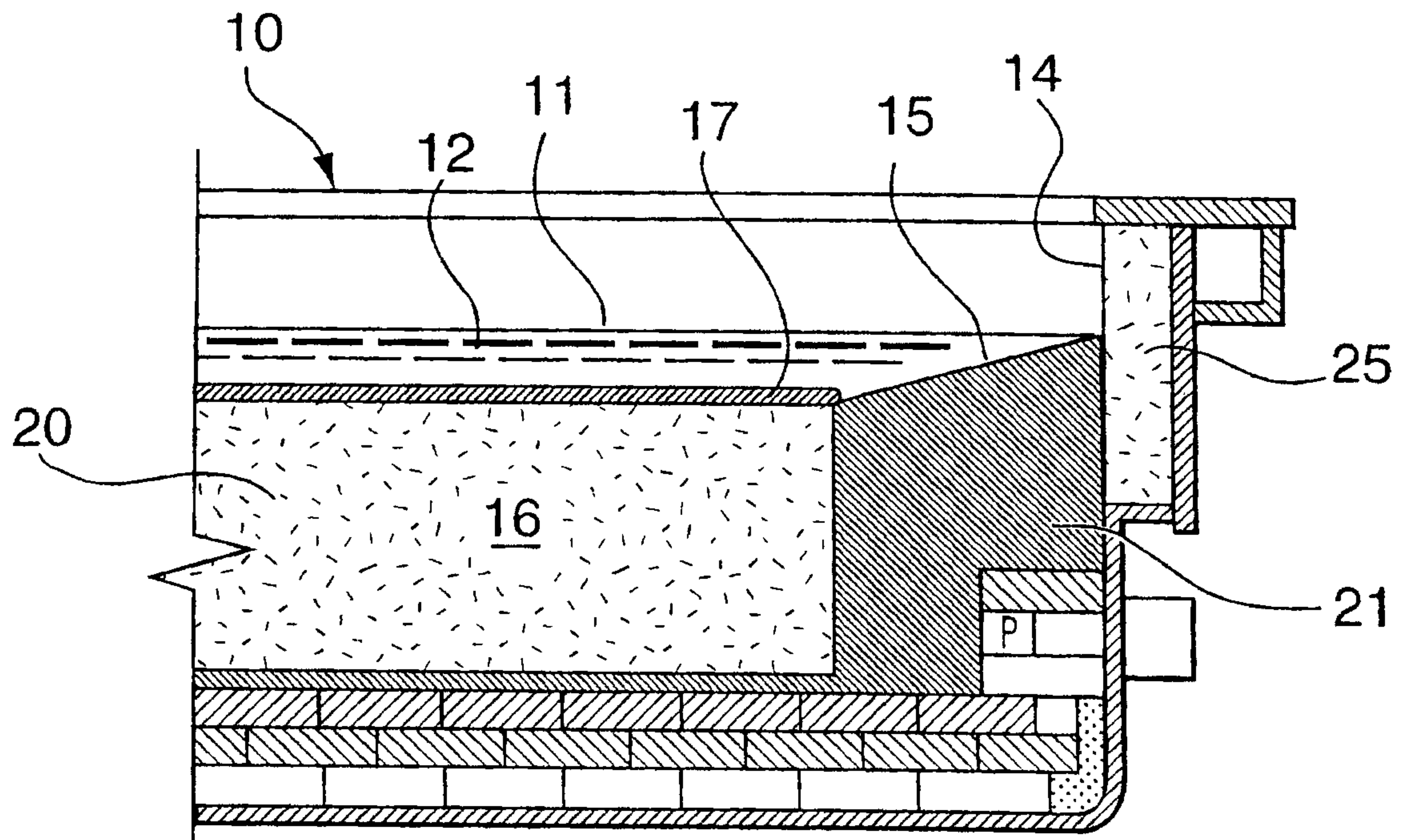

FIG. 2 (Prior Art)