

J. M. BROWNING.
 SAFETY DEVICE FOR FIREARMS.
 APPLICATION FILED MAR. 20, 1913.

1,065,342.

Patented June 24, 1913.

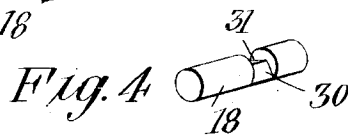
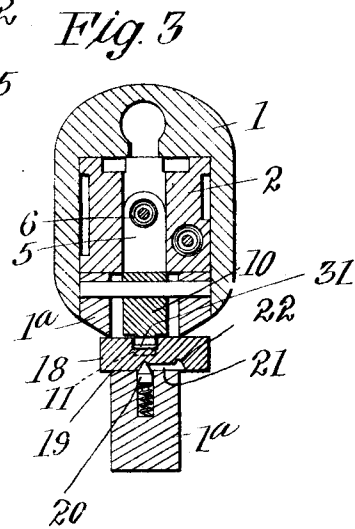
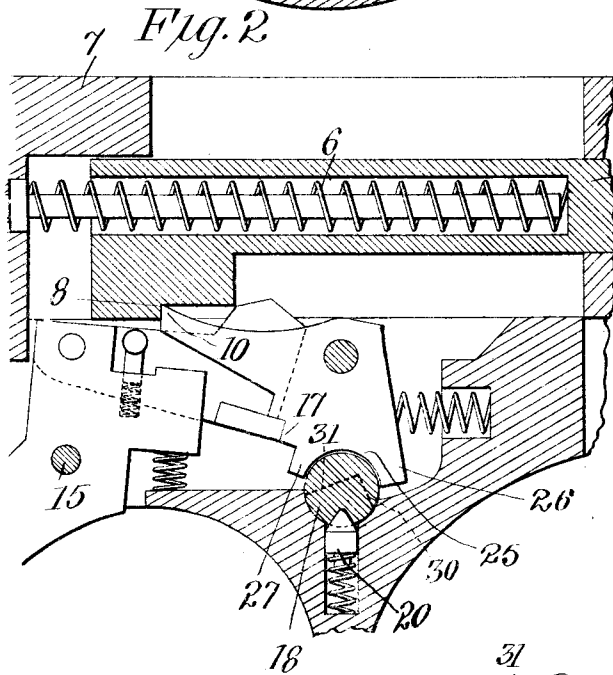
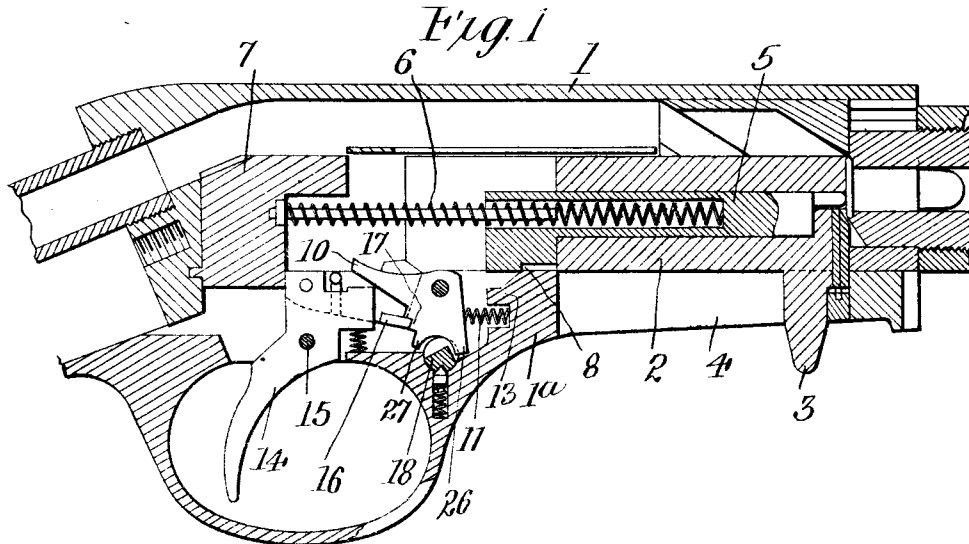

WITNESSES
Joseph L. Stack.
W. B. Brock.

INVENTOR
J. M. Browning
4 Bushy Park Lane, London, W.
 Attorney

UNITED STATES PATENT OFFICE.

JOHN M. BROWNING, OF OGDEN, UTAH.

SAFETY DEVICE FOR FIREARMS.

1,065,342.

Specification of Letters Patent.

Patented June 24, 1913.

Application filed March 20, 1913. Serial No. 755,646.

To all whom it may concern:

Be it known that I, JOHN M. BROWNING, a citizen of the United States, resident of Ogden, Utah, have invented certain new and useful Improvements in Safety Devices for Firearms, of which the following is a specification.

My invention relates to a safety device or safety stop for firearms.

A principal object of the invention is to prevent the locking of the sear in safety position when the hammer is uncocked. Means for accomplishing this is adapted as herein disclosed to a structure in which the sear is free from the hammer after the trigger has been pulled and until the hammer is cocked again. In structures which permit locking of the sear when the hammer is uncocked, and the hammer is free from the sear, it is usually impossible to cock the gun because the sear obstructs the rearward movement of the hammer.

The invention consists in instrumentalities and combinations thereof for carrying out the above and other objects, as will be sufficiently explained hereinafter.

The accompanying drawing shows an exemplifying structure embodying the invention, and it is to be understood that the construction may be varied greatly within the limits of the invention.

Figure 1 is a longitudinal section of a gun-frame with inclosed mechanism, sufficient parts being shown to understand the cooperation of the safety device with other essential parts of a firearm structure. Fig. 2 is an enlarged view of a fragment of Fig. 1, showing the safety stop in active position. Fig. 3 is a transverse section in the vertical plane of the stop. Fig. 4 is a perspective view of the safety stop or pin removed from the gun.

Reference character 1 designates a gun-frame containing a trigger-plate 1^a. Slidably mounted on the trigger-plate is a breech block 2. The breech block carries a cocking lug 3 extending down through slot 4 in the trigger-plate. Slidably mounted within the breech-block is the firing pin 5 actuated by spring 6. The rear end of the spring abuts against the rear end 7 of the trigger-plate. Near the rear end the hammer is provided with a cock-notch 8. In the trigger-plate is pivoted sear 10 adapted to engage the cock notch. The sear is urged to engaging position by a spring 11 and is

prevented from moving too far in that direction by sear member 26 engaging the safety-pin 18. The trigger 14 is pivoted in the trigger-plate at 15 and carries a pivoted connector 16 cooperating with notch 17 on the sear. Adjacent to the lower end of the sear the safety stop or pin 18 is mounted in a transverse socket 19. For convenience, this safety pin is usually round and is prevented from rotating by a spring-pressed plunger 20 carried in the trigger-plate and engaging a longitudinal groove 21 in the pin. At each end of this groove is a depression 32 cooperating with the plunger 20 to hold the pin in either engaged or disengaged position. The lower end of the sear is shaped to embrace the pin as at 25. A member 26 of the sear lies normally in front of the pin and another member 27 lies to the rear of the pin when the arm is cocked, as shown in Fig. 2. At a point opposite the sear, when the pin is in inactive or firing position, the pin is provided with a forwardly arranged depression, cut or groove 30, adapted to cooperate with sear member 26, and at the same point in its length the pin is also provided with an upwardly and rearwardly arranged cut or depression 31 adapted to cooperate with sear member 27.

When the hammer is forward or uncocked, as shown in Fig. 1, it is free from the sear and sear spring 11 holds sear member 26 in engagement with cut 30 of the safety pin 18. Therefore, the pin cannot be moved to safety position until released from the sear. When the hammer is cocked, either by hand or by automatic action, the sear 10 engaging with cock notch 18 of the hammer is held down sufficiently, as shown in Fig. 2, to free sear member 26 from cut 30 of the pin. The pin may then be moved to safety position as shown in Fig. 2. Here the cuts or grooves 30 and 31 of the pin are entirely away from the sear and the sear is locked in engagement with the hammer by reason of the close engagement of its part 25 with the safety pin and the gun cannot be accidentally discharged either by pulling the trigger or otherwise.

The mechanism described affords means for determining whether the gun is cocked or not, because if it is not cocked the sear will engage cut 30 and prevent the safety pin from being moved to safety position, while if the gun is cocked the pin can be moved to safety position, as above described.

Without the provision of cut 30 the sear will not be locked by the safety pin when the hammer is uncocked and the pin could, therefore, be moved to safety position, thus locking the sear, and then if it were attempted to cock the hammer it would be impossible to do so because the sear would not be free to depress and allow the hammer to pass back sufficiently to engage cock-notch 8 with the sear.

I claim:

1. In a firearm, the combination of a hammer, a sear and a safety pin mounted to move laterally in relation to the sear to lock the same when the hammer is cocked, the

sear and pin being provided with cooperating means to prevent the pin from being moved to safety position when the hammer is not cocked.

2. In a firearm, the combination of a frame, a sear, a hammer free from the sear when uncocked, a safety pin mounted to move laterally in the frame, and means by which the safety pin is engaged with the sear and prevented from moving to safety position when the hammer is not cocked.

JOHN M. BROWNING.

Witnesses:

L. M. TAYLOR,
MATTHEW GALT.